HM5241605C Series

131,072-word × 16-bit × 2-bank Synchronous Dynamic RAM

HITACHI

ADE-203-381B (Z)

Rev. 2.0

Jan. 7, 1997

Description

All inputs and outputs are referred to the rising edge of the clock input. The HM5241605C is offered in 2 banks for improved performance.

Features

- 3.3V Power supply
- Clock frequency: 80 MHz (V_{CC} min = 3.0 V)/66 MHz/57 MHz (max)
: 83 MHz (V_{CC} min = 3.15 V)
- LVTTL interface
- Single pulsed \overline{RAS}
- 2 Banks can operate simultaneously and independently
- Burst read/write operation and burst read/single write operation capability
- Programmable burst length: 1/2/4/8/full page (256)
- Programmable burst sequence:
 - Sequential
 - Interleave
- Full page burst length capability
 - Sequential burst
 - Burst stop capability
- Programmable \overline{CAS} latency: 1/2/3
- Byte control by DQMU and DQML
- 1024 refresh cycles: 16 ms
- 2 variations of refresh
 - Auto refresh
 - Self refresh

HM5241605C Series

Ordering Information

Type No.	Frequency	Package
HM5241605CJ-12	80(83*) MHz	400-mil 50-pin plastic SOJ (CP-50D)
HM5241605CJ-15	66 MHz	
HM5241605CJ-17	57 MHz	
HM5241605CTT-12	80(83*) MHz	400-mil 50-pin plastic TSOP II (TTP-50D)
HM5241605CTT-15	66 MHz	
HM5241605CTT-17	57 MHz	

Note: 1. V_{CC} min = 3.15 V

Pin Arrangement

HM5241605CJ Series

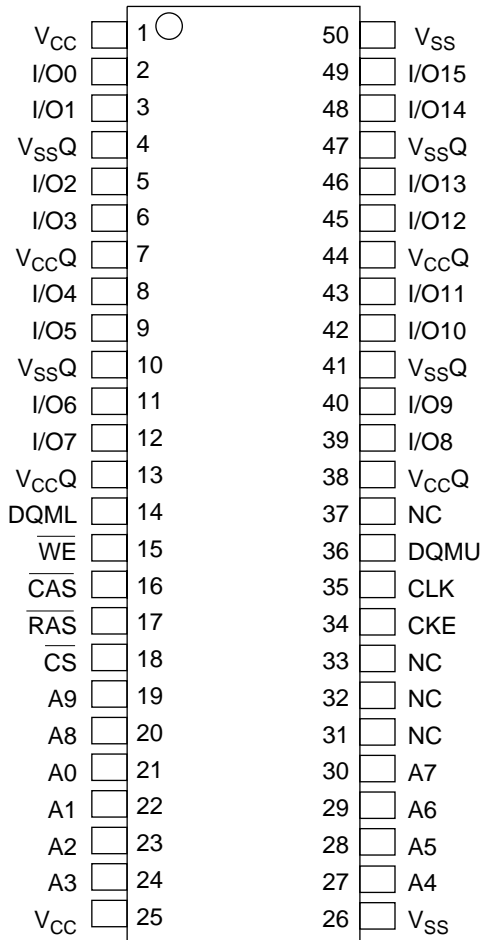

(Top view)

HM5241605CTT Series

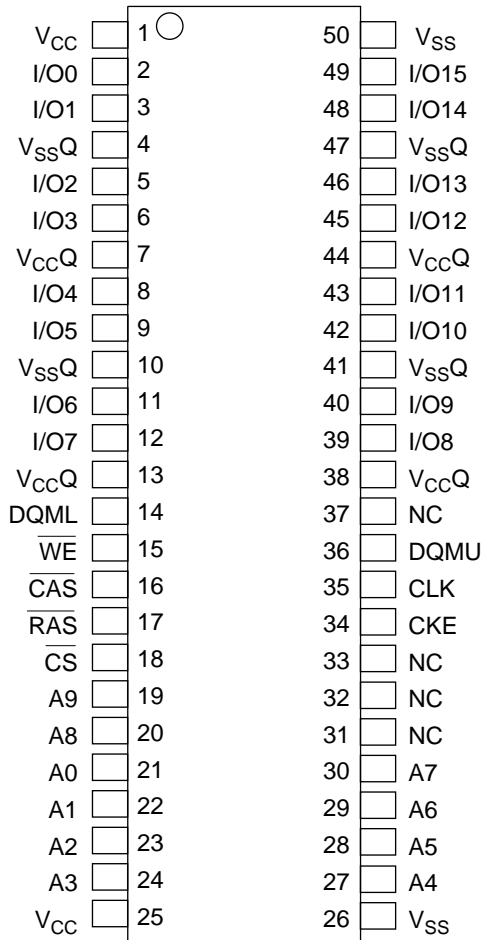

(Top view)

HM5241605C Series

Pin Description

Pin name	Function
A0 to A9	Address input <ul style="list-style-type: none">— Row address A0 to A8— Column address A0 to A7— Bank select address A9
I/O0 to I/O15	Data-input/output
$\overline{\text{CS}}$	Chip select
$\overline{\text{RAS}}$	Row address strobe command
$\overline{\text{CAS}}$	Column address strobe command
$\overline{\text{WE}}$	Write enable command
DQMU	Upper byte input/output mask
DQML	Lower byte input/output mask
CLK	Clock input
CKE	Clock enable
V_{CC}	Power for internal circuit
V_{SS}	Ground for internal circuit
V_{CCQ}	Power for I/O circuit
V_{SSQ}	Ground for I/O circuit
NC	No connection

Block Diagram

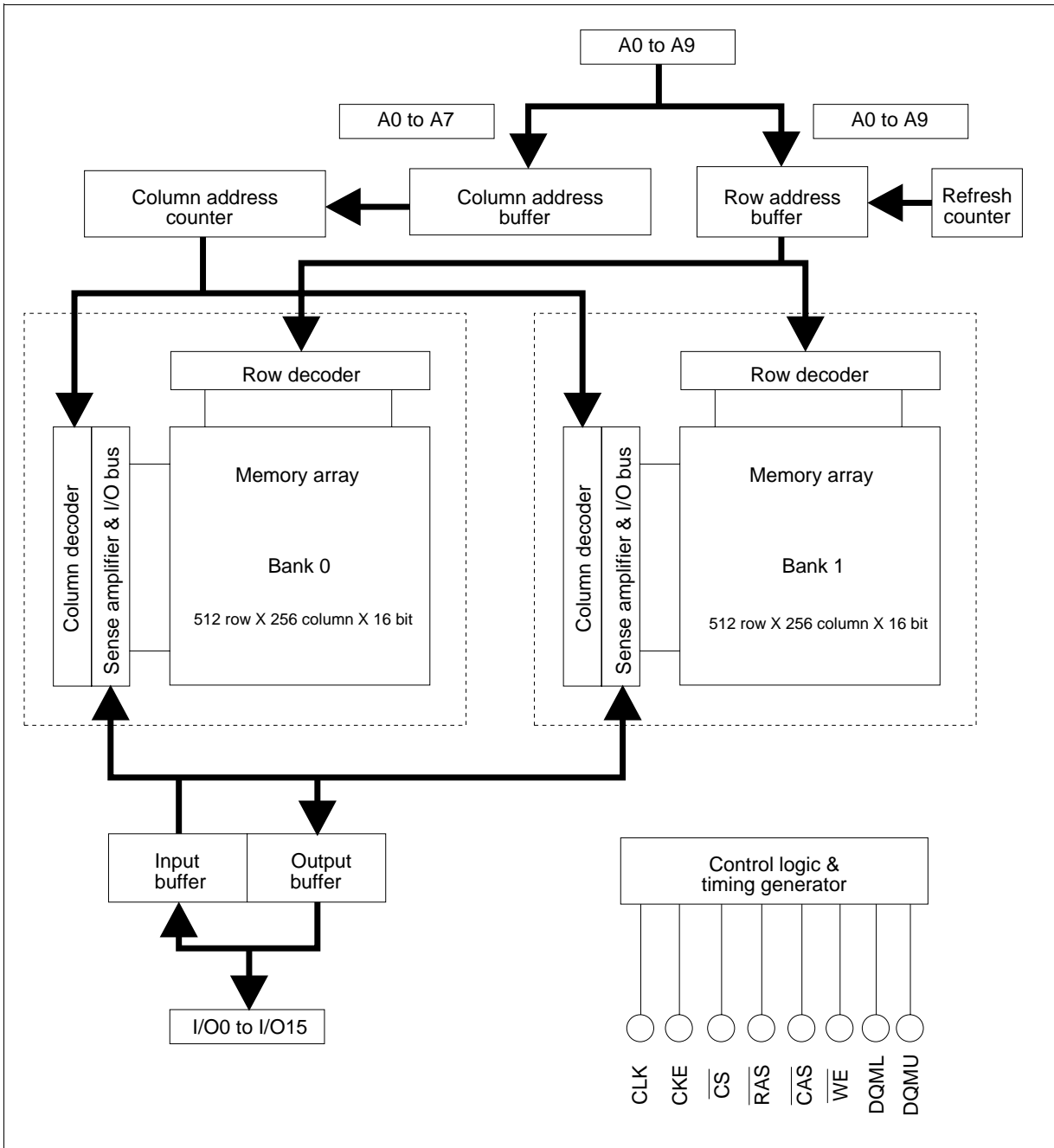

Pin Functions

CLK (input pin): CLK is the master clock input to this pin. The other input signals are referred at CLK rising edge.

$\overline{\text{CS}}$ (input pin): When $\overline{\text{CS}}$ is Low, the command input cycle becomes valid. When $\overline{\text{CS}}$ is High, all inputs are ignored. However, internal operations (bank active, burst operations, etc.) are held.

$\overline{\text{RAS}}$, $\overline{\text{CAS}}$, and $\overline{\text{WE}}$ (input pins): Although these pin names are the same as those of conventional DRAMs, they function in a different way. These pins define operation commands (read, write, etc.) depending on the combination of their voltage levels. For details, refer to the command operation section.

A0 to A8 (input pins): Row address (AX0 to AX8) is determined by A0 to A8 level at the bank active command cycle CLK rising edge. Column address (AY0 to AY7) is determined by A0 to A7 level at the read or write command cycle CLK rising edge. And this column address becomes burst access start address. A8 defines the precharge mode. When A8 = High at the precharge command cycle, both banks are precharged. But when A8 = Low at the precharge command cycle, only the bank that is selected by A9 (BS) is precharged.

A9 (input pin): A9 is a bank select signal (BS). The memory array of the HM5241605C is divided into bank 0 and bank 1, both which contain 512 row \times 256 column \times 16 bits. If A9 is Low, bank 0 is selected, and if A9 is High, bank 1 is selected.

CKE (input pin): This pin determines whether or not the next CLK is valid. If CKE is High, the next CLK rising edge is valid. If CKE is Low, the next CLK rising edge is invalid. This pin is used for power-down and clock suspend modes.

DQMU/DQML (input pins): DQMU controls upper byte and DQML controls lower byte input/output buffers.

Read operation: If DQMU/DQML is High, the output buffer becomes High-Z. If the DQMU/DQML is Low, the output buffer becomes Low-Z.

Write operation: If DQMU/DQML is High, the previous data is held (the new data is not written). If DQMU/DQML is Low, the data is written.

I/O0 to I/O15 (I/O pins): Data is input to and output from these pins. These pins are the same as those of a conventional DRAM.

V_{CC} and V_{CC}Q (power supply pins): 3.3 V is applied. (V_{CC} is for the internal circuit and V_{CC}Q is for the output buffer.)

V_{SS} and V_{SS}Q (power supply pins): Ground is connected. (V_{SS} is for the internal circuit and V_{SS}Q is for the output buffer.)

Command Operation

Command Truth Table

The synchronous DRAM recognizes the following commands specified by the $\overline{\text{CS}}$, $\overline{\text{RAS}}$, $\overline{\text{CAS}}$, $\overline{\text{WE}}$ and address pins.

Function	Symbol	CKE		$\overline{\text{CS}}$	$\overline{\text{RAS}}$	$\overline{\text{CAS}}$	$\overline{\text{WE}}$	A9	A8	A0 to A7
		n - 1	n							
Ignore command	DESL	H	×	H	×	×	×	×	×	×
No operation	NOP	H	×	L	H	H	H	×	×	×
Burst stop in full page	BST	H	×	L	H	H	L	×	×	×
Column address and read command	READ	H	×	L	H	L	H	V	L	V
Read with auto-precharge	READ A	H	×	L	H	L	H	V	H	V
Column address and write command	WRIT	H	×	L	H	L	L	V	L	V
Write with auto-precharge	WRIT A	H	×	L	H	L	L	V	H	V
Row address strobe and bank active	ACTV	H	×	L	L	H	H	V	V	V
Precharge select bank	PRE	H	×	L	L	H	L	V	L	×
Precharge all bank	PALL	H	×	L	L	H	L	×	H	×
Refresh	REF/SELF	H	V	L	L	L	H	×	×	×
Mode register set	MRS	H	×	L	L	L	L	V	V	V

Note: H: V_{IH} , L: V_{IL} , ×: V_{IH} or V_{IL} , V: Valid address input

Ignore command [DESL]: When this command is set ($\overline{\text{CS}}$ is High), the synchronous DRAM ignore command input at the clock. However, the internal status is held.

No operation [NOP]: This command is not an execution command. However, the internal operations continue.

Burst stop in full-page [BST]: This command stops a full-page burst operation (burst length = full-page (256)), and is illegal otherwise. Full page burst continues until this command is input. When data input/output is completed for a full-page of data (256), it automatically returns to the start address, and input/output is performed repeatedly.

Column address strobe and read command [READ]: This command starts a read operation. In addition, the start address of burst read is determined by the column address (AY0 to AY7) and the bank select address (BS). After the read operation, the output buffer becomes High-Z.

Read with auto precharge [READ A]: This command automatically performs a precharge operation after a burst read with a burst length of 1, 2, 4 or 8. When the burst length is full-page (256), this command is illegal.

HM5241605C Series

Column address strobe and write command [WRIT]: This command starts a write operation. When the burst write mode is selected, the column address (AY0 to AY7) and the bank select address (A9) become the burst write start address. When the single write mode is selected, data is only written to the location specified by the column address (AY0 to AY7) and the bank select address (A9).

Write with auto precharge [WRIT A]: This command automatically performs a precharge operation after a burst write with a length of 1, 2, 4 or 8, or after a single write operation. When the burst length is full-page (256), this command is illegal.

Row address strobe and bank activate [ACTV]: This command activates the bank that is selected by A9 (BS) and determines the row address (AX0 to AX8). When A9 is Low, bank 0 is activated. When A9 is High, bank 1 is activated.

Precharge selected bank [PRE]: This command starts precharge operation for the bank selected by A9. If A9 is Low, bank 0 is selected. If A9 is High, bank 1 is selected.

Precharge all banks [PALL]: This command starts a precharge operation for all banks.

Refresh [REF/SELF]: This command starts the refresh operation. There are two types of refresh operation, the one is auto refresh, and the other is self refresh. For details, refer to the CKE truth table section.

Mode register set [MRS]: Synchronous DRAM has a mode register that defines how it operates. The mode register is specified by the address pins (A0 to A9) at the mode register set cycle. For details, refer to the mode register configuration. After power on, the contents of the mode register are undefined, execute the mode register set command to set up the mode register.

DQM Truth Table

Function	Symbol	CKE		DQMU	DQML
		n - 1	n		
Upper byte write enable/output enable	ENBU	H	×	L	×
Lower byte write enable/output enable	ENBL	H	×	×	L
Upper byte write inhibit/output disable	MASKU	H	×	H	×
Lower byte write inhibit/output disable	MASKL	H	×	×	H

Note: H: V_{IH} , L: V_{IL} , ×: V_{IH} or V_{IL} .

The HM5241605C series can mask input/output data by means of DQMU and DQML. DQMU masks the upper byte and DQML masks the lower byte.

During reading, the output buffer is set to Low-Z by setting DQMU/DQML to Low, enabling data output. On the other hand, when DQMU/DQML is set to High, the output buffer becomes High-Z, disabling data output.

During writing, data is written by setting DQMU/DQML to Low. When DQMU/DQML is set to High, the previous data is held (the new data is not written). Desired data can be masked during burst read or burst write by setting DQMU/DQML. For details, refer to the DQM control section of the HM5241605C operating instructions.

CKE Truth Table

Current state	Function		CKE n - 1	n	\overline{CS}	\overline{RAS}	\overline{CAS}	\overline{WE}	Address
Active	Clock suspend mode entry		H	L	H	×	×	×	×
Any	Clock suspend		L	L	×	×	×	×	×
Clock suspend	Clock suspend mode exit		L	H	L	H	H	H	×
			L	H	H	×	×	×	×
Idle	Auto-refresh command	REF	H	H	L	L	L	H	×
Idle	Self-refresh entry	SELF	H	L	L	L	L	H	×
Idle	Power down entry		H	L	L	H	H	H	×
			H	L	H	×	×	×	×
Self refresh	Self refresh exit	SELFEX	L	H	L	H	H	H	×
			L	H	H	×	×	×	×
Power down	Power down exit		L	H	L	H	H	H	×
			L	H	H	×	×	×	×

Note: H: V_{IH} . L: V_{IL} . ×: V_{IH} or V_{IL} .

Clock suspend mode entry: The synchronous DRAM enters clock suspend mode from active mode by setting CKE to Low. The clock suspend mode changes depending on the current status (1 clock before) as shown below.

ACTIVE clock suspend: This suspend mode ignores inputs after the next clock by internally maintaining the bank active status.

READ suspend and READ A suspend: The data being output is held (and continues to be output).

WRITE suspend and WRIT A suspend: In this mode, external signals are not accepted. However, the internal state is held.

Clock suspend: During clock suspend mode, keep the CKL to Low.

Clock suspend mode exit: The synchronous DRAM exits from clock suspend mode by setting CKE to High during the clock suspend state.

IDLE: In this state, all banks are not selected, and completed precharge operation.

Auto refresh command [REF]: When this command is input from the IDLE state, the synchronous DRAM starts auto-refresh operation. (The auto-refresh is the same as the CBR refresh of conventional DRAMs.) During the auto-refresh operation, refresh address and bank select address are generated inside the synchronous DRAM. For every auto-refresh cycle, the internal address counter is updated. Accordingly, 1,024 times are required to refresh the entire memory. Before executing the auto-refresh command, all the banks must be in the IDLE state. In addition, since the precharge for all banks is automatically performed after auto-refresh, no precharge command is required after auto refresh.

HM5241605C Series

Self refresh entry [SELF]: When this command is input during the IDLE state, the synchronous DRAM starts self refresh operation. After the execution of this command, self refresh continues while CKE is Low. Since self refresh is performed internally and automatically, external refresh operations are unnecessary.

Power down mode entry: When this command is executed during the IDLE state, the synchronous DRAM enters power down mode. In power down mode, power consumption is suppressed by cutting off the initial input circuit.

Self refresh exit: When this command is executed during self refresh mode, the synchronous DRAM can exit from self refresh mode. After exiting from self refresh mode, the synchronous DRAM enters the IDLE state.

Power down exit: When this command is executed at the power down mode, the synchronous DRAM can exit from power down mode. After exiting from power down mode, the synchronous DRAM enters the IDLE state.

Function Truth Table

The following table shows the operations that are performed when each command is issued in each mode of the synchronous DRAM.

Current state	\overline{CS}	\overline{RAS}	\overline{CAS}	\overline{WE}	Address	Command	Operation
Precharge	H	×	×	×	×	DESL	Enter IDLE after t_{RP}
	L	H	H	H	×	NOP	Enter IDLE after t_{RP}
	L	H	H	L	×	BST	ILLEGAL
	L	H	L	H	BA, CA, A8	READ/READ A	ILLEGAL
	L	H	L	L	BA, CA, A8	WRIT/WRIT A	ILLEGAL
	L	L	H	H	BA, RA	ACTV	ILLEGAL
	L	L	H	L	BA, A8	PRE, PALL	ILLEGAL
	L	L	L	H	×	REF, SELF	ILLEGAL
	L	L	L	L	MODE	MRS	ILLEGAL
Idle	H	×	×	×	×	DESL	NOP
	L	H	H	H	×	NOP	NOP
	L	H	H	L	×	BST	NOP
	L	H	L	H	BA, CA, A8	READ/READ A	ILLEGAL
	L	H	L	L	BA, CA, A8	WRIT/WRIT A	ILLEGAL
	L	L	H	H	BA, RA	ACTV	Bank and row active
	L	L	H	L	BA, A8	PRE, PALL	NOP
	L	L	L	H	×	REF, SELF	Refresh
	L	L	L	L	MODE	MRS	Mode register set

Current state	$\overline{\text{CS}}$	$\overline{\text{RAS}}$	$\overline{\text{CAS}}$	$\overline{\text{WE}}$	Address	Command	Operation
Row active	H	×	×	×	×	DESL	NOP
	L	H	H	H	×	NOP	NOP
	L	H	H	L	×	BST	NOP
	L	H	L	H	BA, CA, A8	READ/READ A	Begin read
	L	H	L	L	BA, CA, A8	WRIT/WRIT A	Begin write
	L	L	H	H	BA, RA	ACTV	Other bank active ILLEGAL on same bank* ³
	L	L	H	L	BA, A8	PRE, PALL	Precharge
	L	L	L	H	×	REF, SELF	ILLEGAL
	L	L	L	L	MODE	MRS	ILLEGAL
Read	H	×	×	×	×	DESL	Continue burst to end
	L	H	H	H	×	NOP	Continue burst to end
	L	H	H	L	×	BST	Burst stop to full page
	L	H	L	H	BA, CA, A8	READ/READ A	Continue burst read to $\overline{\text{CAS}}$ latency and New read
	L	H	L	L	BA, CA, A8	WRIT/WRIT A	Term burst read/start write
	L	L	H	H	BA, RA	ACTV	Other bank active ILLEGAL on same bank* ³
	L	L	H	L	BA, A8	PRE, PALL	Term burst read and Precharge
	L	L	L	H	×	REF, SELF	ILLEGAL
	L	L	L	L	MODE	MRS	ILLEGAL
Read with auto precharge	H	X	×	×	×	DESL	Continue burst to end and precharge
	L	H	H	H	×	NOP	Continue burst to end and precharge
	L	H	H	L	×	BST	ILLEGAL
	L	H	L	H	BA, CA, A8	READ/READ A	ILLEGAL
	L	H	L	L	BA, CA, A8	WRIT/WRIT A	ILLEGAL
	L	L	H	H	BA, RA	ACTV	Other bank active ILLEGAL on same bank* ³
	L	L	H	L	BA, A8	PRE, PALL	ILLEGAL
	L	L	L	H	×	REF, SELF	ILLEGAL
	L	L	L	L	MODE	MRS	ILLEGAL

HM5241605C Series

Current state	\overline{CS}	\overline{RAS}	\overline{CAS}	\overline{WE}	Address	Command	Operation
Write	H	×	×	×	×	DESL	Continue burst to end
	L	H	H	H	×	NOP	Continue burst to end
	L	H	H	L	×	BST	Burst stop on full page
	L	H	L	H	BA, CA, A8	READ/READ A	Term burst and New read
	L	H	L	L	BA, CA, A8	WRIT/WRIT A	Term burst and New write
	L	L	H	H	BA, RA	ACTV	Other bank active ILLEGAL on same bank*3
	L	L	H	L	BA, A8	PRE, PALL	Term burst write and Precharge*2
	L	L	L	H	×	REF, SELF	ILLEGAL
	L	L	L	L	MODE	MRS	ILLEGAL
Write with auto precharge	H	×	×	×	×	DESL	Continue burst to end and precharge
	L	H	H	H	×	NOP	Continue burst to end and precharge
	L	H	H	L	×	BST	ILLEGAL
	L	H	L	H	BA, CA, A8	READ/READ A	ILLEGAL
	L	H	L	L	BA, CA, A8	WRIT/WRIT A	ILLEGAL
	L	L	H	H	BA, RA	ACTV	Other bank active ILLEGAL on same bank*3
	L	L	H	L	BA, A8	PRE, PALL	ILLEGAL
	L	L	L	H	×	REF, SELF	ILLEGAL
	L	L	L	L	MODE	MRS	ILLEGAL
Refresh (auto refresh)	H	×	×	×	×	DESL	Enter IDLE after t_{RC}
	L	H	H	H	×	NOP	Enter IDLE after t_{RC}
	L	H	H	L	×	BST	Enter IDLE after t_{RC}
	L	H	L	H	BA, CA, A8	READ/READ A	ILLEGAL
	L	H	L	L	BA, CA, A8	WRIT/WRIT A	ILLEGAL
	L	L	H	H	BA, RA	ACTV	ILLEGAL
	L	L	H	L	BA, A8	PRE, PALL	ILLEGAL
	L	L	L	H	×	REF, SELF	ILLEGAL
	L	L	L	L	MODE	MRS	ILLEGAL

Notes 1. H: V_{IH} , L: V_{IL} , ×: V_{IH} or V_{IL} .

The other combinations are inhibit.

2. An interval of t_{RWL} is required between the final valid data input and the precharge command.

3. If t_{RRD} is not satisfied, this operation is illegal.

From [PRECHARGE]

To [DESL], [NOP] or [BST]: When these commands are executed, the synchronous DRAM enters the IDLE state after t_{RP} has elapsed from the completion of precharge.

From [IDLE]

To [DESL], [NOP], [BST], [PRE] or [PALL]: These commands result in no operation.

To [ACTV]: The bank specified by the address pins and the ROW address is activated.

To [REF], [SELF]: The synchronous DRAM enters refresh mode (auto refresh or self refresh).

To [MRS]: The synchronous DRAM enters the mode register set cycle.

From [ROW ACTIVE]

To [DESL], [NOP] or [BST]: These commands result in no operation.

To [READ], [READ A]: A read operation starts. (However, an interval of t_{RCD} is required.)

To [WRIT], [WRIT A]: A write operation starts. (However, an interval of t_{RCD} is required.)

To [ACTV]: This command makes the other bank active. (However, an interval of t_{RRD} is required.) Attempting to make the currently active bank active results in an illegal command.

To [PRE], [PALL]: These commands set the synchronous DRAM to precharge mode. (However, an interval of t_{RAS} is required.)

From [READ]

To [DESL], [NOP]: These commands continue read operations until the burst operation is completed.

To [BST]: This command stops a full-page burst.

To [READ], [READ A]: Data output by the previous read command continues to be output. After $\overline{\text{CAS}}$ latency, the data output resulting from the next command will start.

To [WRIT], [WRIT A]: These commands stop a burst read, and start a write cycle.

To [ACTV]: This command makes other banks bank active. (However, an interval of t_{RRD} is required.) Attempting to make the currently active bank active results in an illegal command.

To [PRE], [PALL]: These commands stop a burst read, and the synchronous DRAM enters precharge mode.

HM5241605C Series

From [READ with AUTO-PRECHARGE]

To [DESL], [NOP]: These commands continue read operations until the burst operation is completed, and the synchronous DRAM then enters precharge mode.

To [ACTV]: This command makes other banks bank active. (However, an interval of t_{RRD} is required.) Attempting to make the currently active bank active results in an illegal command.

From [WRITE]

To [DESL], [NOP]: These commands continue write operations until the burst operation is completed.

To [BST]: This command stops a full-page burst.

To [READ], [READ A]: These commands stop a burst and start a read cycle.

To [WRIT], [WRIT A]: These commands stop a burst and start the next write cycle.

To [ACTV]: This command makes the other bank active. (However, an interval of t_{RRD} is required.) Attempting to make the currently active bank active results in an illegal command.

To [PRE], [PALL]: These commands stop burst write and the synchronous DRAM then enters precharge mode.

From [WRITE with AUTO PRECHARGE]

To [DESL], [NOP]: These commands continue write operations until the burst is completed, and the synchronous DRAM enters precharge mode.

To [ACTV]: This command makes the other bank active. (However, an interval of t_{RRD} is required.) Attempting to make the currently active bank active results in an illegal command.

From [REFRESH]

To [DESL], [NOP], [BST]: After an auto refresh cycle (after t_{RC}), the synchronous DRAM automatically enters the IDLE state.

Mode Register Configuration

The mode register is set by the input to the address pins (A0 to A9) during mode register set cycles. The mode register consists of five sections, each of which is assigned to address pins.

A9 and A8: (OPCODE): The synchronous DRAM has two types of write modes. One is the burst write mode, and the other is the single write mode. These bits specify write mode.

Burst read and BURST WRITE: Burst write is performed for the specified burst length starting from the column address specified in the write cycle.

Burst read and SINGLE WRITE: Data is only written to the column address specified during the write cycle, regardless of the burst length.

A7: Keep this bit Low at the mode register set cycle.

A6, A5, A4: (LMODE): These pins specify the $\overline{\text{CAS}}$ latency.

A3: (BT): A burst type is specified. When full-page burst is performed, only "sequential" can be selected.

A2, A1, A0: (BL): These pins specify the burst length.

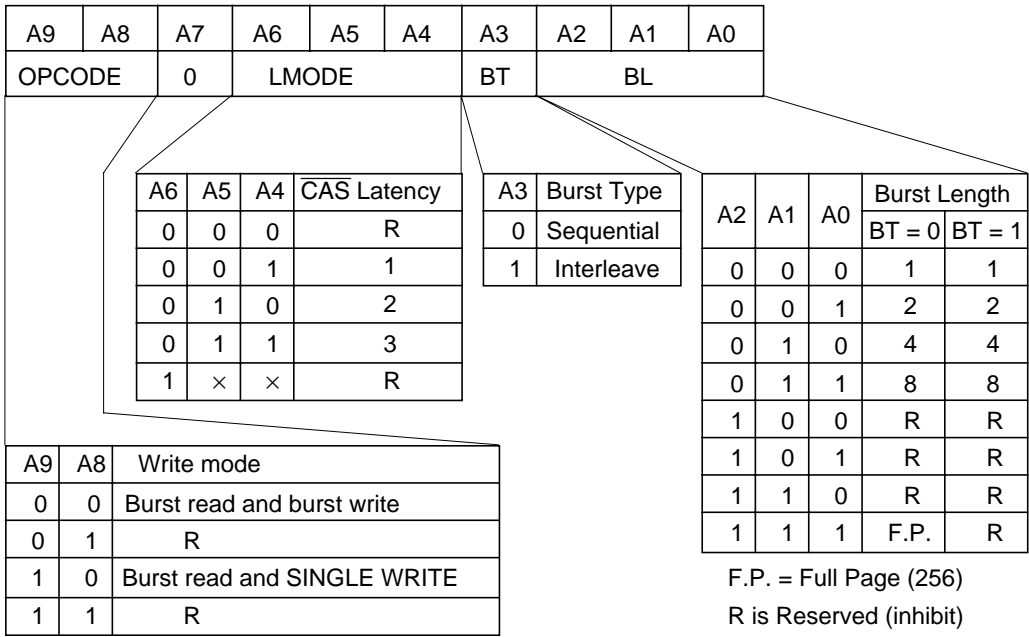

Burst Sequence

Burst length = 2

Starting Ad.	Addressing(decimal)	
A0	Sequence	Interleave
0	0, 1,	0, 1,
1	1, 0,	1, 0,

Burst length = 4

Starting Ad.	Addressing(decimal)		
A1	A0	Sequence	Interleave
0	0	0, 1, 2, 3,	0, 1, 2, 3,
0	1	1, 2, 3, 0,	1, 0, 3, 2,
1	0	2, 3, 0, 1,	2, 3, 0, 1,
1	1	3, 0, 1, 2,	3, 2, 1, 0,

Burst length = 8

Starting Ad.			Addressing(decimal)	
A2	A1	A0	Sequence	Interleave
0	0	0	0, 1, 2, 3, 4, 5, 6, 7,	0, 1, 2, 3, 4, 5, 6, 7,
0	0	1	1, 2, 3, 4, 5, 6, 7, 0,	1, 0, 3, 2, 5, 4, 7, 6,
0	1	0	2, 3, 4, 5, 6, 7, 0, 1,	2, 3, 0, 1, 6, 7, 4, 5,
0	1	1	3, 4, 5, 6, 7, 0, 1, 2,	3, 2, 1, 0, 7, 6, 5, 4,
1	0	0	4, 5, 6, 7, 0, 1, 2, 3,	4, 5, 6, 7, 0, 1, 2, 3,
1	0	1	5, 6, 7, 0, 1, 2, 3, 4,	5, 4, 7, 6, 1, 0, 3, 2,
1	1	0	6, 7, 0, 1, 2, 3, 4, 5,	6, 7, 4, 5, 2, 3, 0, 1,
1	1	1	7, 0, 1, 2, 3, 4, 5, 6,	7, 6, 5, 4, 3, 2, 1, 0,

Operation of HM5241605C Series

Read/Write Operations

Bank active: Before executing a read or write operation, the corresponding bank and the row address must be activated by the bank active (ACTV) command. Either bank 0 or bank 1 is activated according to the status of the A9 pin, and the row address (AX0 to AX8) is activated by the A0 to A8 pins at the bank active command cycle. An interval of t_{RCD} is required between the bank active command input and the following read/write command input.

Read operation: A read operation starts when a read command is input. Output buffer becomes Low-Z in the ($\overline{\text{CAS}}$ Latency - 1) cycle after read command set. HM5241605C series can perform a burst read operation. The burst length can be set to 1,2,4,8 or full-page (256). The start address for a burst read is specified by the column address (AY0 to AY7) and the bank select address (A9) at the read command set cycle. In a read operation, data output starts after the number of cycles specified by the $\overline{\text{CAS}}$ Latency. The $\overline{\text{CAS}}$ Latency can be set to 1, 2, 3. When the burst length is 1, 2, 4 or 8, the Dout buffer automatically becomes High-Z at the next cycle after the successive burst-length data has been output. When the burst length is full-page (256), data is repeatedly output until the burst stop command is input. The $\overline{\text{CAS}}$ latency and burst length must be specified at the mode register.

$\overline{\text{CAS}}$ Latency

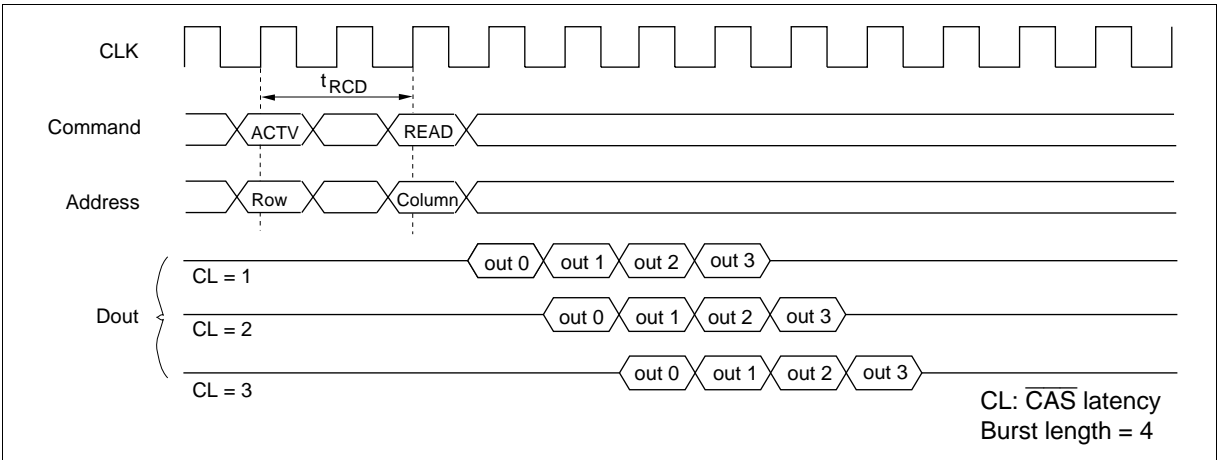

Burst Length

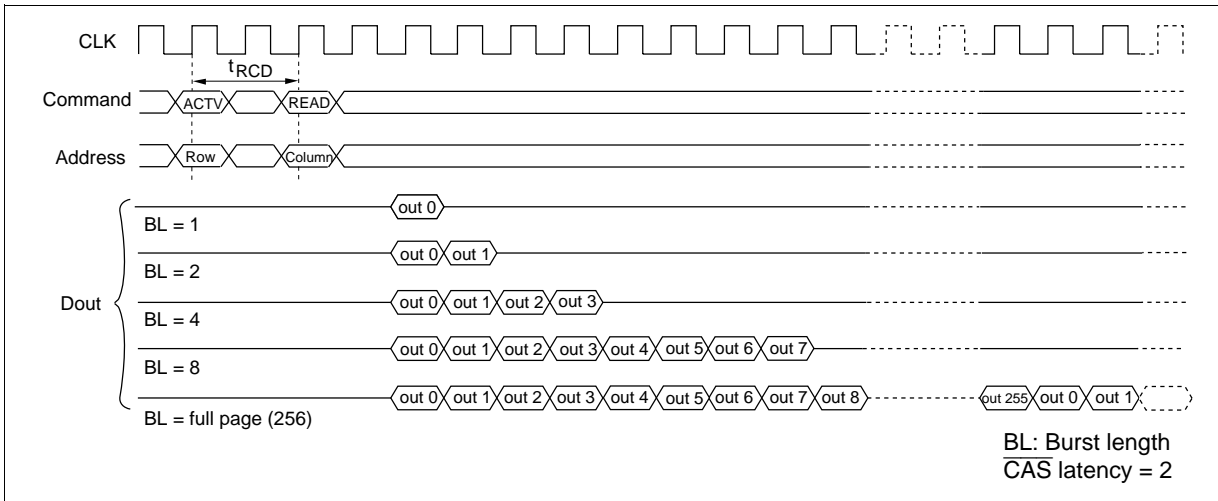

Write operation: Burst write or single write mode is selected by the OPCODE (A9, A8) of the mode register.

1. Burst write: A burst write operation is enabled by setting OPCODE (A9, A8) to (0, 0). A burst write starts in the same cycle as a write command set. (The latency of data input is 0.) The burst length can be set to 1, 2, 4, 8, and full-page, like burst read operations. The write start address is specified by the column address (AY0 to AY7) and the bank select address (A9) at the write command set cycle.

Burst Write

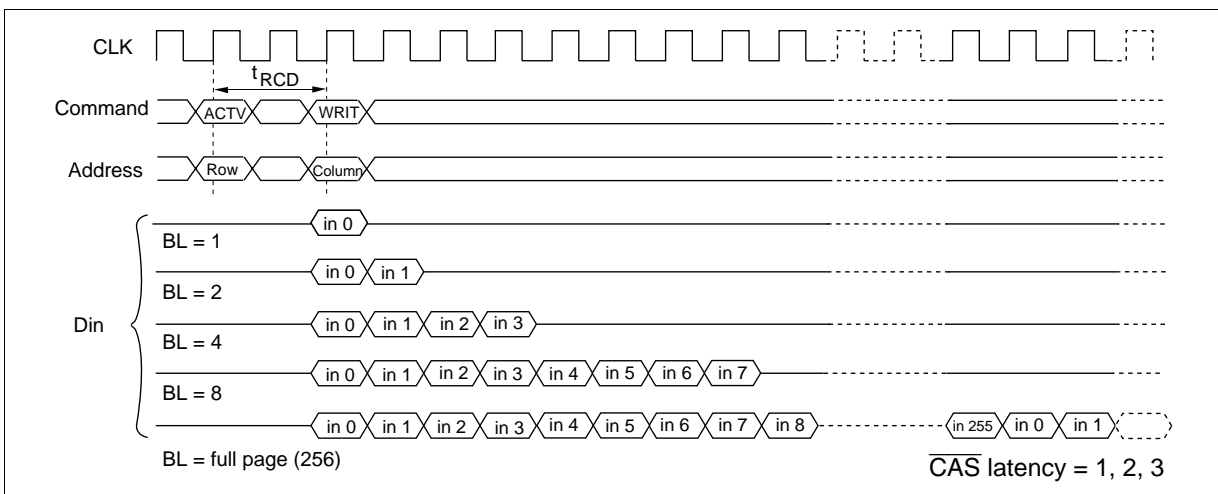

HM5241605C Series

2. Single write: A single write operation is enabled by setting OPCODE (A9, A8) to (1, 0). In a single write operation, data is only written to the column address (AY0 to AY7) and the bank select address (A9) specified by the write command set cycle without regard to the burst length setting. (The latency of data input is 0).

Single Write

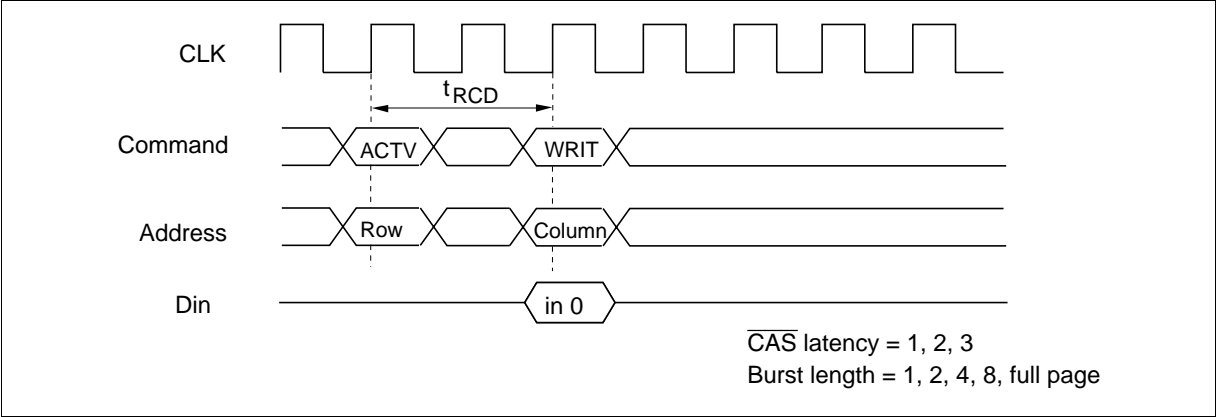

Auto Precharge

Read with auto precharge: In this operation, since precharge is automatically performed after completing a read operation, a precharge command need not be executed after each read operation. The command executed for the same bank after the execution of this command must be the bank active (ACTV) command. In addition, an interval defined by I_{APR} is required before execution of the next command.

CAS latency	Precharge start cycle
3	2 cycle before the final data is output
2	1 cycle before the final data is output
1	same cycle as the final data is output

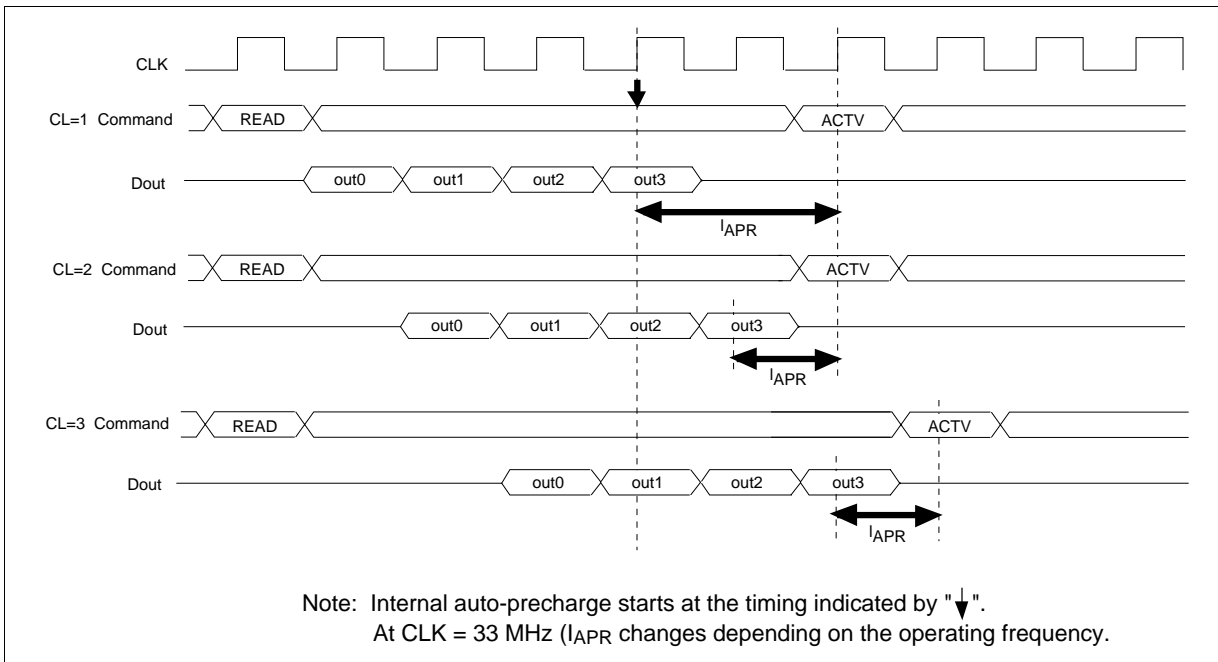

HM5241605C Series

Write with auto precharge: In this operation, since precharge is automatically performed after completing a burst write or single write operation, a precharge command need not be executed after each write operation. The command executed for the same bank after the execution of this command must be the bank active (ACTV) command. In addition, an interval of I_{APW} is required between the final valid data input and input of the next command.

Burst Write (Burst Length = 4)

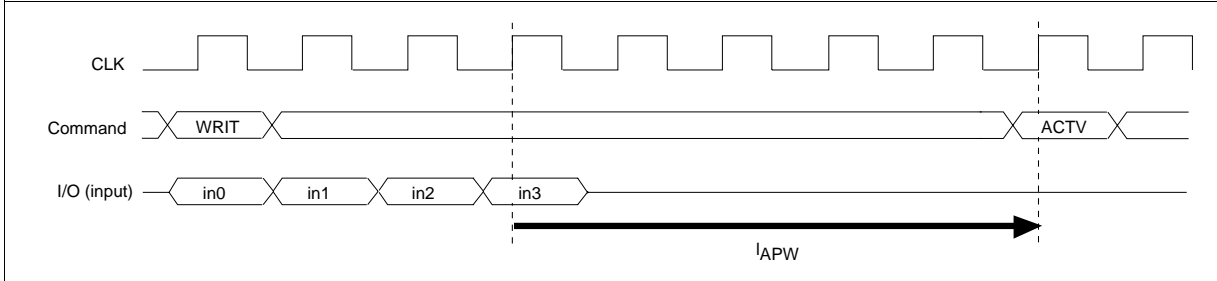

Single Write

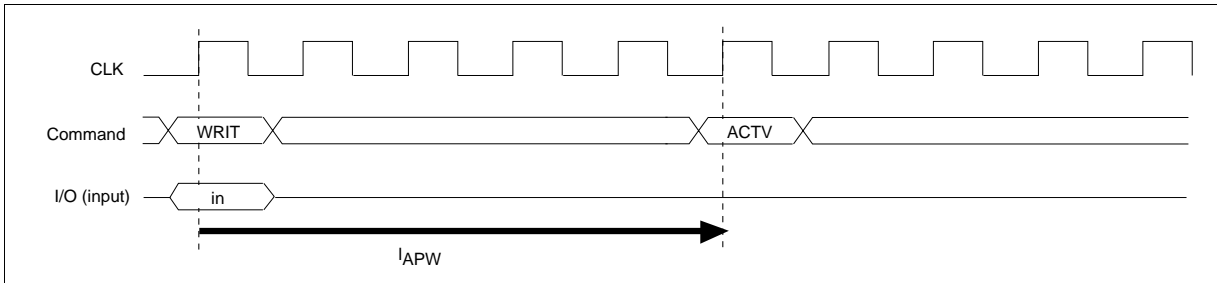

Full-page Burst Stop

Burst stop command during burst read: The burst stop (BST) command is used to stop data output during a full-page burst. The BST command sets the output buffer to High-Z and stops the full-page burst read. The timing from command input to the last data changes depending on the $\overline{\text{CAS}}$ latency setting. When the $\overline{\text{CAS}}$ latency is 3, the data becomes invalid two cycles after the BST command. In addition, the BST command is valid only during full-page burst mode, and is invalid with burst lengths of 1, 2, 4 and 8.

$\overline{\text{CAS}}$ latency	BST to valid data	BST to High impedance
1	0	1
2	1	2
3	2	3

CAS Latency = 1, Burst Length = full page

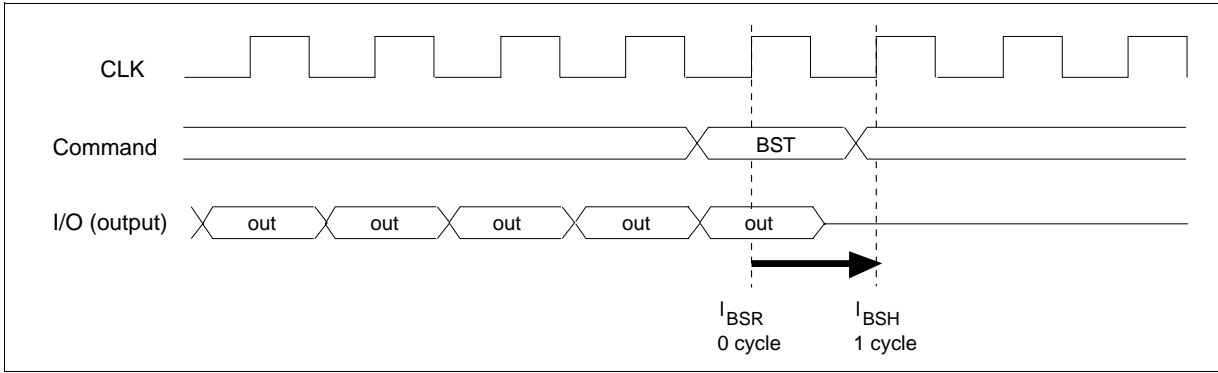

CAS Latency = 2, Burst Length = full page

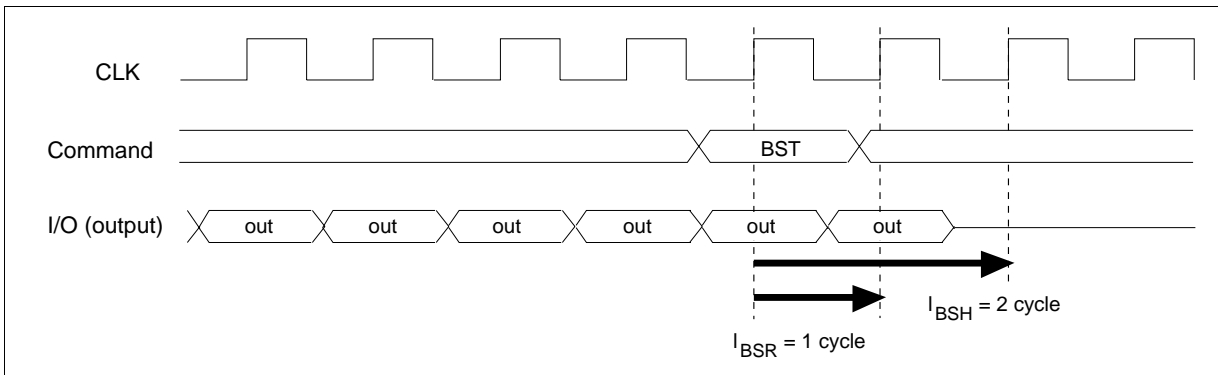

CAS Latency = 3, Burst Length = full page

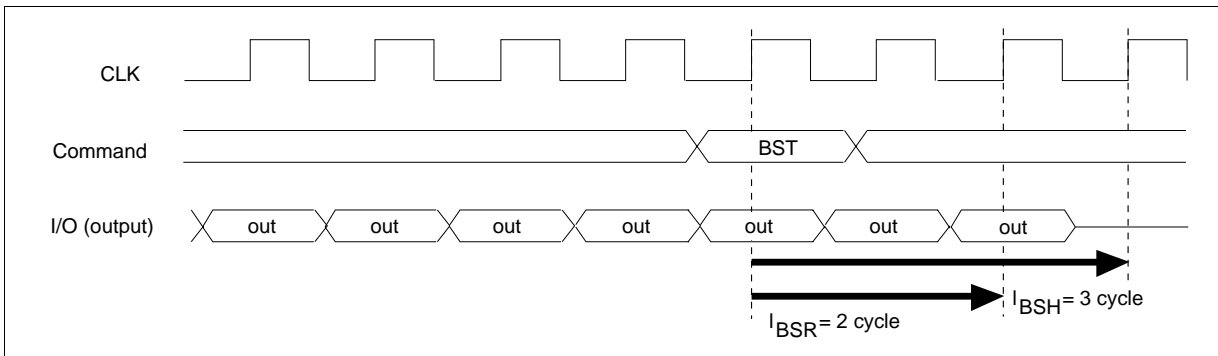

HM5241605C Series

Burst stop command at burst write: The burst stop command (BST command) is used to stop data input during a full-page burst write. Data is still written in the same cycle as the BST command, but no data is written in subsequent cycles. In addition, the BST command is only valid during full-page burst mode, and is invalid with burst lengths of 1, 2, 4 and 8. And an interval of t_{RWL} is required between the BST command and the next precharge command.

Burst Length = full page

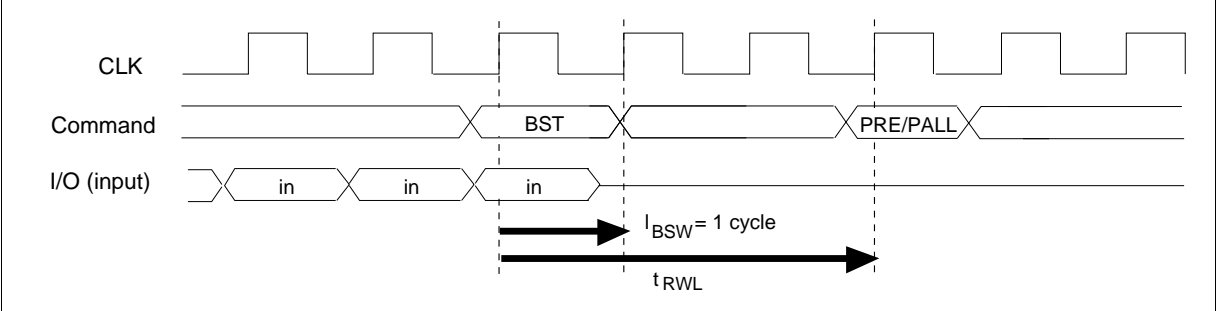

Command Intervals

Read command to Read command interval

1. Same bank, same ROW address: When another read command is executed at the same ROW address of the same bank as the preceding read command execution, the second read can be performed after an interval of no less than 1 cycle. Even when the first command is a burst read that is not yet finished, the data read by the second command will be valid.

READ to READ Command Interval (same ROW address in same bank)

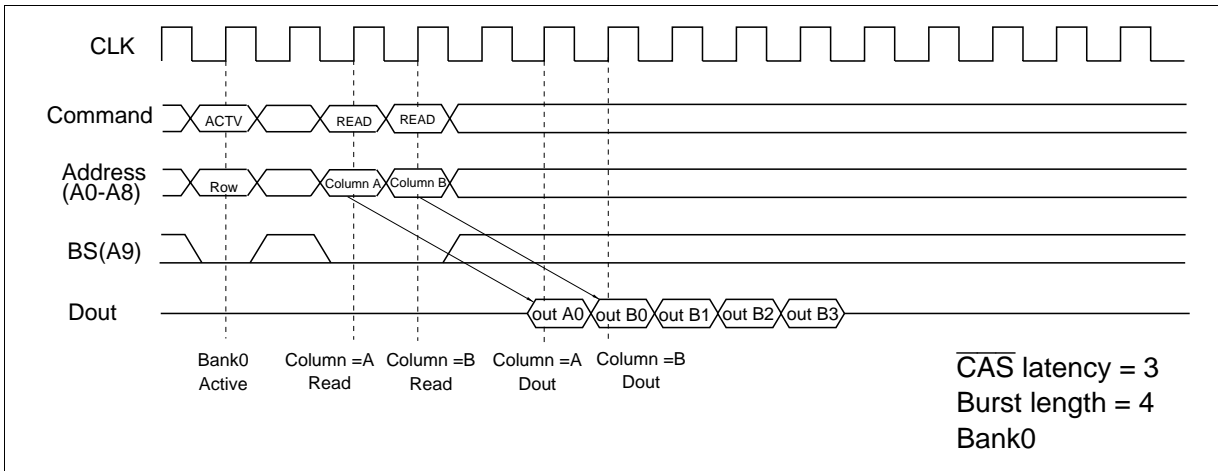

2. Same bank, different ROW address: When the ROW address changes on same bank, consecutive read commands cannot be executed; it is necessary to separate the two read commands with a precharge command and a bank-active command.

3. Different bank: When the bank changes, the second read can be performed after an interval of no less than 1 cycle, provided that the other bank is in the bank-active state. Even when the first command is a burst read that is not yet finished, the data read by the second command will be valid.

READ to READ Command Interval (different bank)

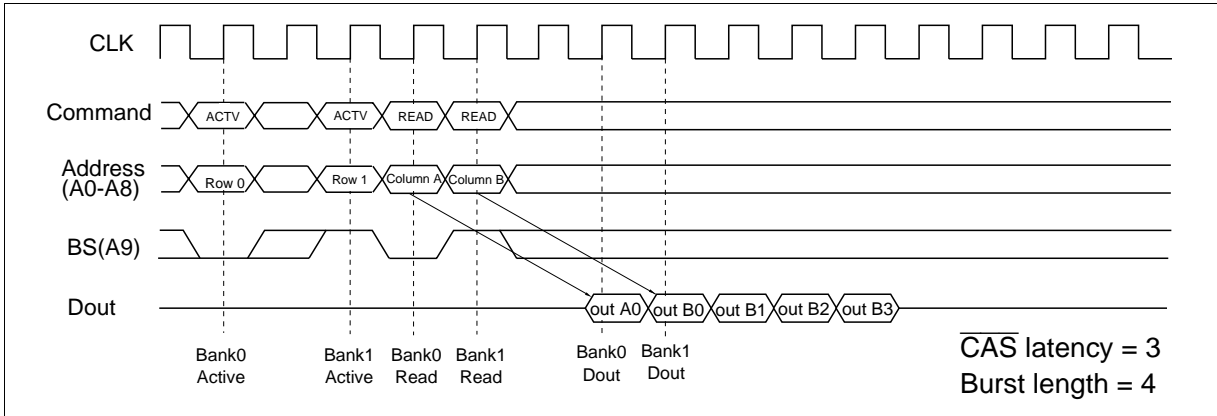

Write command to Write command interval

1. Same bank, same ROW address: When another write command is executed at the same ROW address of the same bank as the preceding write command, the second write can be performed after an interval of no less than 1 cycle. In the case of burst writes, the second write command has priority.

WRITE to WRITE Command Interval (same ROW address in same bank)

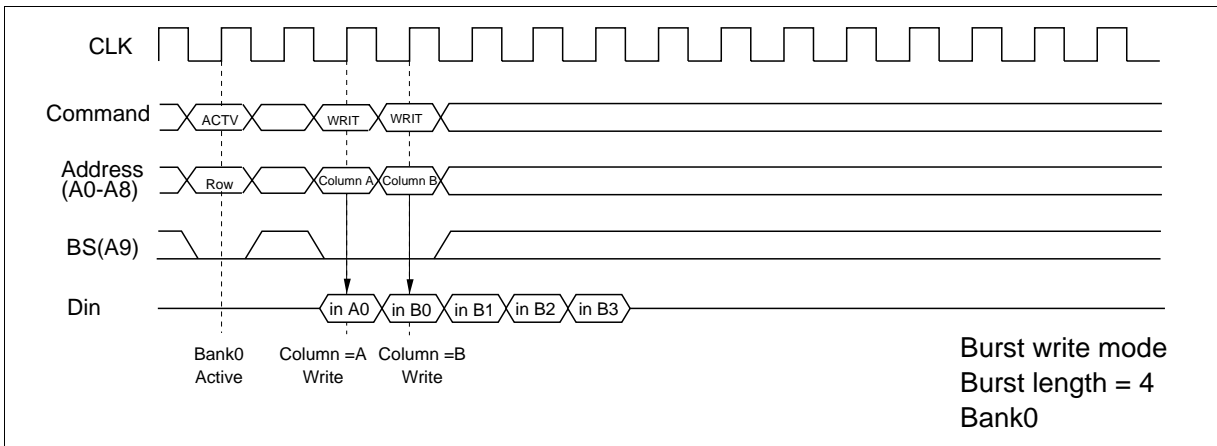

2. Same bank, different ROW address: When the ROW address changes, consecutive write commands cannot be executed; it is necessary to separate the two write commands with a precharge command and a bank-active command.

3. Different bank: When the bank changes, the second write can be performed after an interval of no less than 1 cycle, provided that the other bank is in the bank-active state. In the case of burst write, the second write command has priority.

WRITE to WRITE Command Interval (different bank)

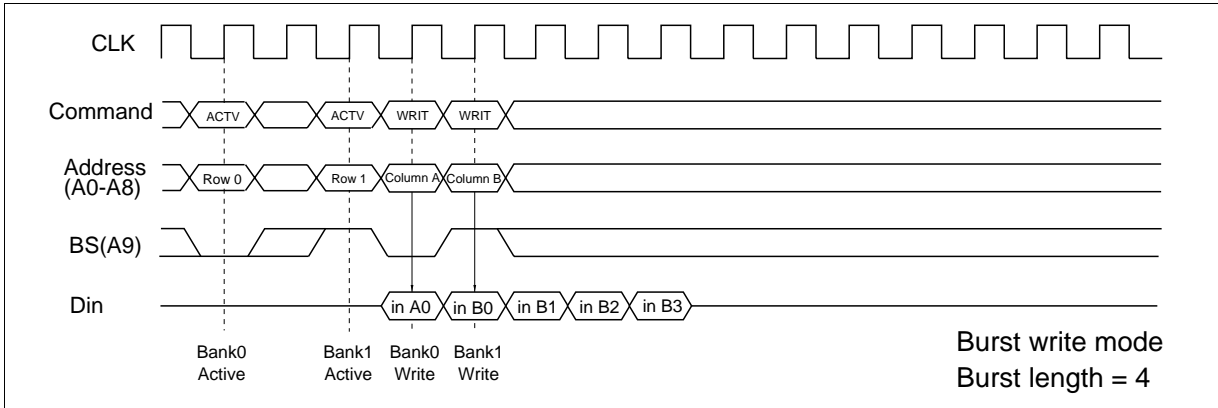

Read command to Write command interval

1. Same bank, same ROW address: When the write command is executed at the same ROW address of the same bank as the preceding read command, the write command can be performed after an interval of no less than 1 cycle. However, DQMU/DQML must be set High so that the output buffer becomes High-Z before data input.

READ to Write Command Interval (1)

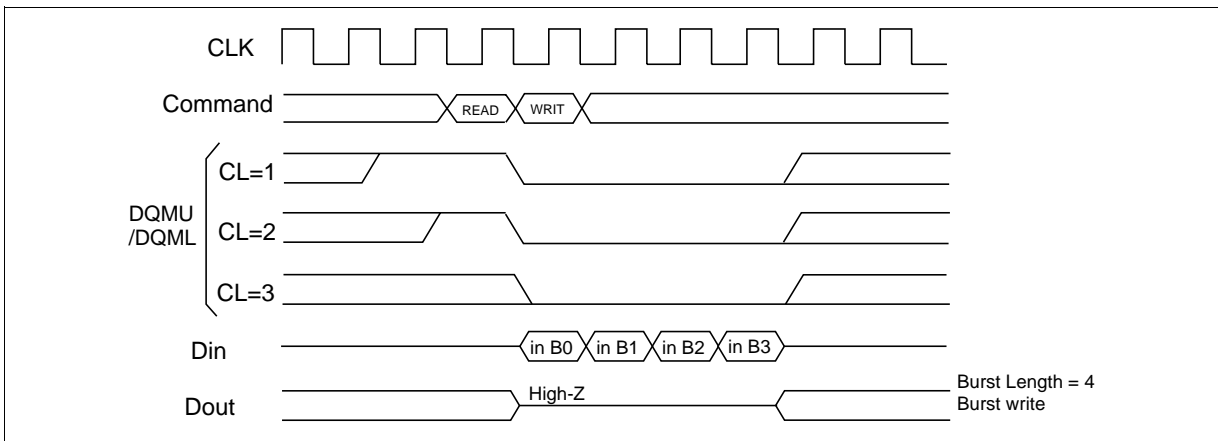

READ to Write Command Interval (2)

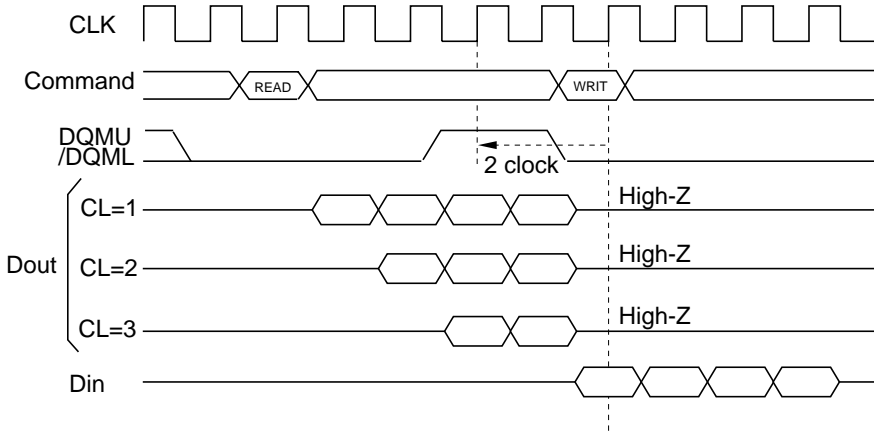

2. Same bank, different ROW address: When the ROW address changes, consecutive write commands cannot be executed; it is necessary to separate the two commands with a precharge command and a bank-active command.

3. Different bank: When the bank changes, the write command can be performed after an interval of no less than 1 cycle, provided that the other bank is in the bank-active state. However, DQML/DQMU must be set High so that the output buffer becomes High-Z before data input.

Write command to Read command interval

1. Same bank, same ROW address: When the read command is executed at the same ROW address of the same bank as the preceding write command, the read command can be performed after an interval of no less than 1 cycle. However, in the case of a burst write, data will continue to be written until one cycle before the read command is executed.

WRITE to READ Command Interval (1)

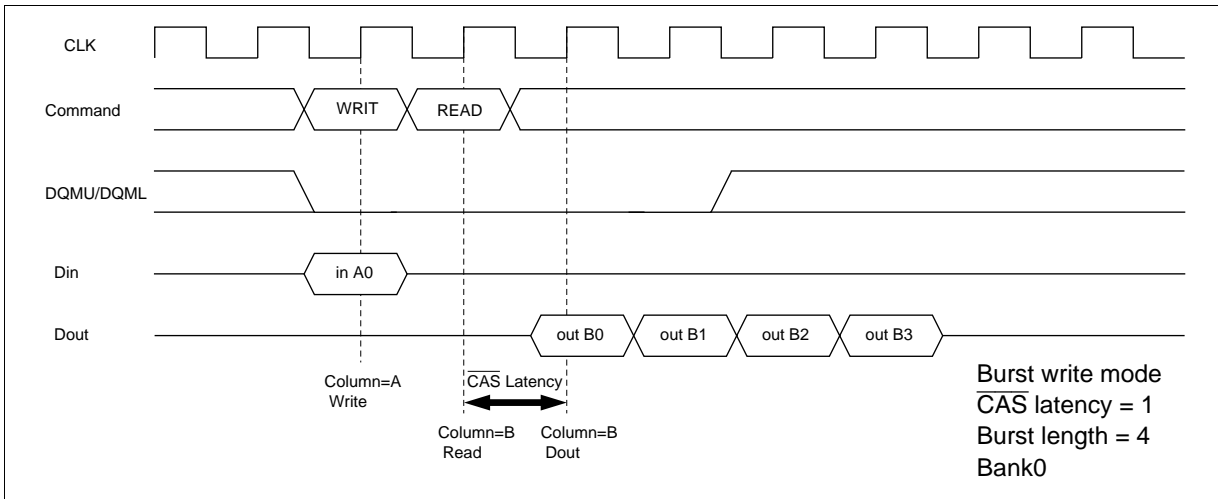

WRITE to READ Command Interval (2)

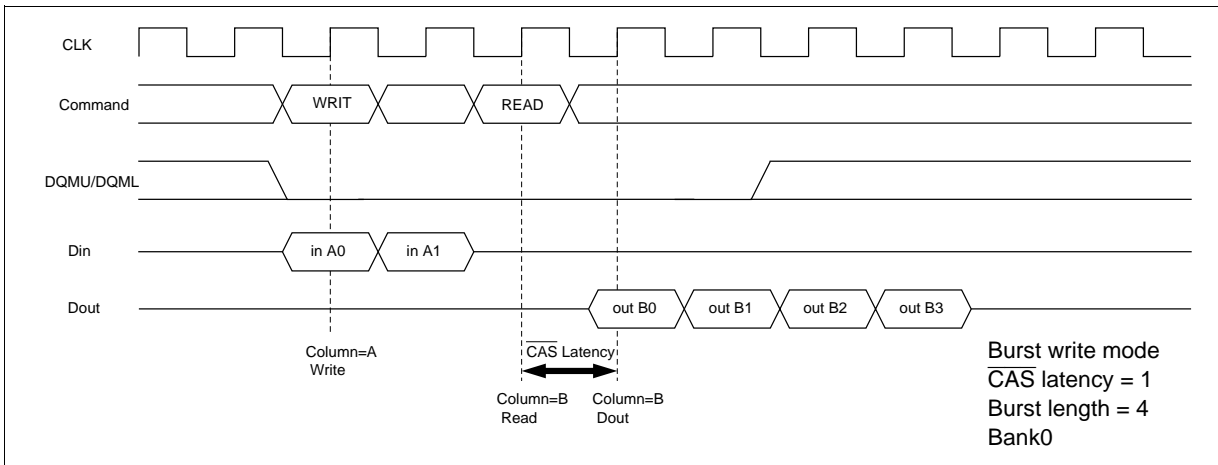

2. Same bank, different ROW address: When the ROW address changes, consecutive read commands cannot be executed; it is necessary to separate the two commands with a precharge command and a bank-active command.

3. Different bank: When the bank changes, the read command can be performed after an interval of no less than 1 cycle, provided that the other bank is in the bank-active state. However, in the case of a burst write, data will continue to be written until one cycle before the read command is executed (as in the case of the same bank and the same address).

Read command to Precharge command interval (same bank): When the precharge command is executed for the same bank as the read command that preceded it, the minimum interval between the two commands is one cycle. However, since the output buffer then becomes High-Z after the cycles defined by I_{HZP} , there is a possibility that burst read data output will be interrupted, if the precharge command is input during burst read. To read all data by burst read, the cycles defined by I_{EP} must be assured as an interval from the final data output to precharge command execution.

READ to PRECHARGE Command Interval (same bank): To output all data

CAS Latency = 1, Burst Length = 4

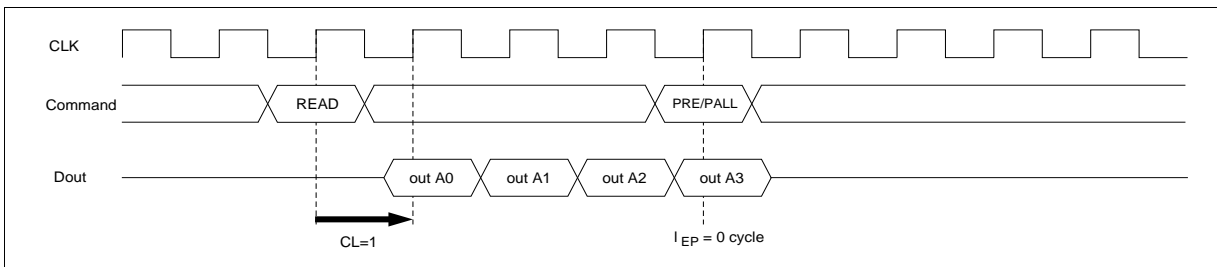

CAS Latency = 2, Burst Length = 4

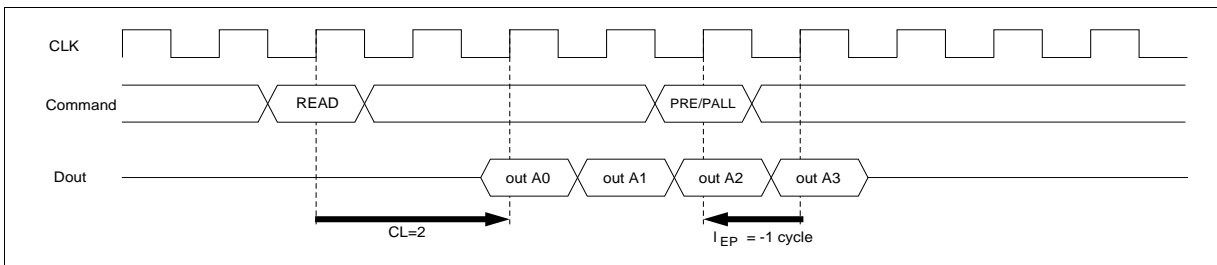

$\overline{\text{CAS}}$ Latency = 3, Burst Length = 4

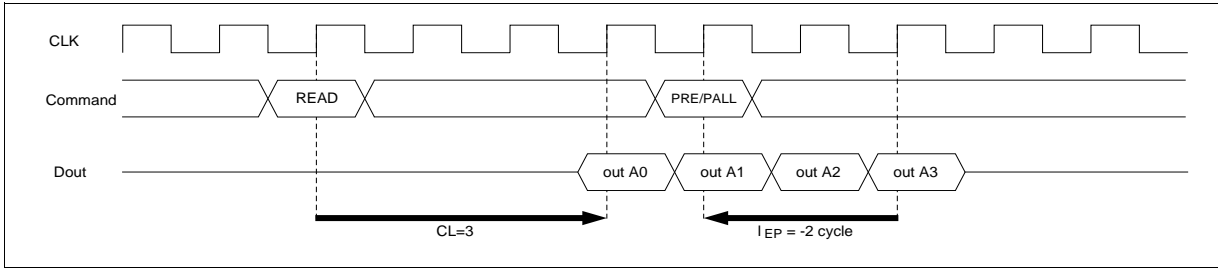

READ to PRECHARGE Command Interval (same bank): To stop output data

$\overline{\text{CAS}}$ Latency = 1, Burst Length = 2, 4, 8

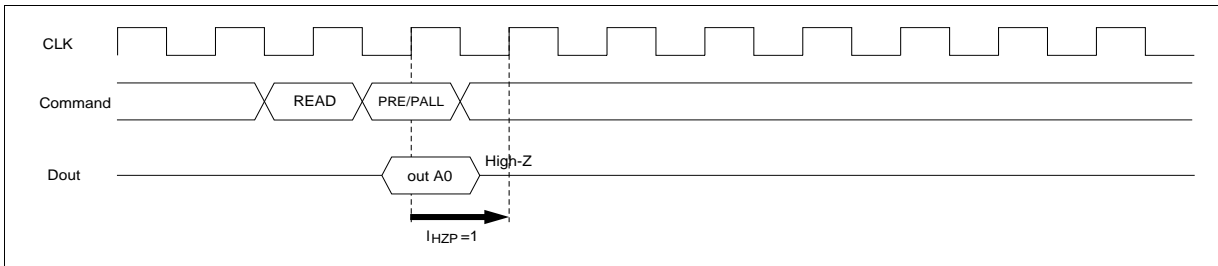

$\overline{\text{CAS}}$ Latency = 2, Burst Length = 2, 4, 8

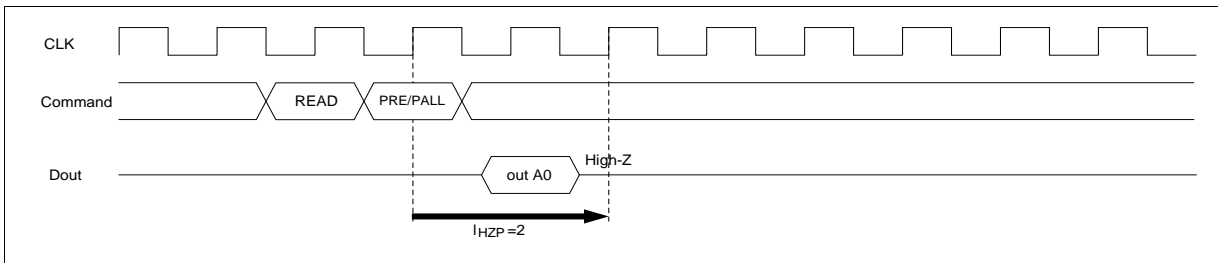

$\overline{\text{CAS}}$ Latency = 3, Burst Length = 2, 4, 8

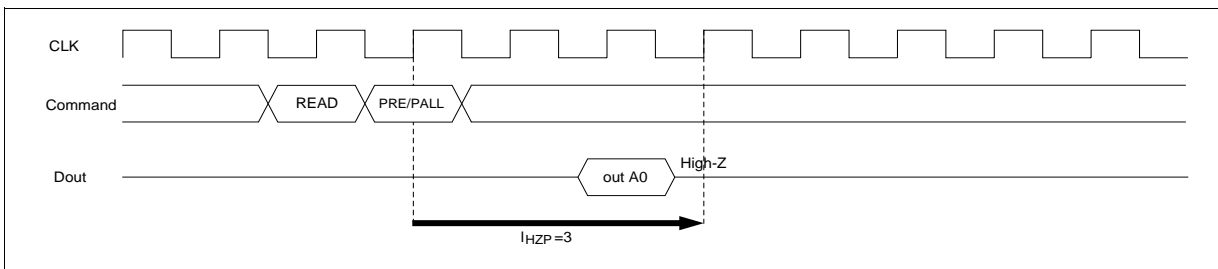

HM5241605C Series

Write command to Precharge command interval (same bank): When the precharge command is executed for the same bank as the write command that preceded it, the minimum interval between the two commands is 1 cycle. However, if the burst write operation is unfinished, the input data must be masked by means of DQMU and DQML for assurance of the cycle defined by t_{RWL} .

WRITE to PRECHARGE Command Interval (same bank)

Burst Length = 4 (To stop write operation)

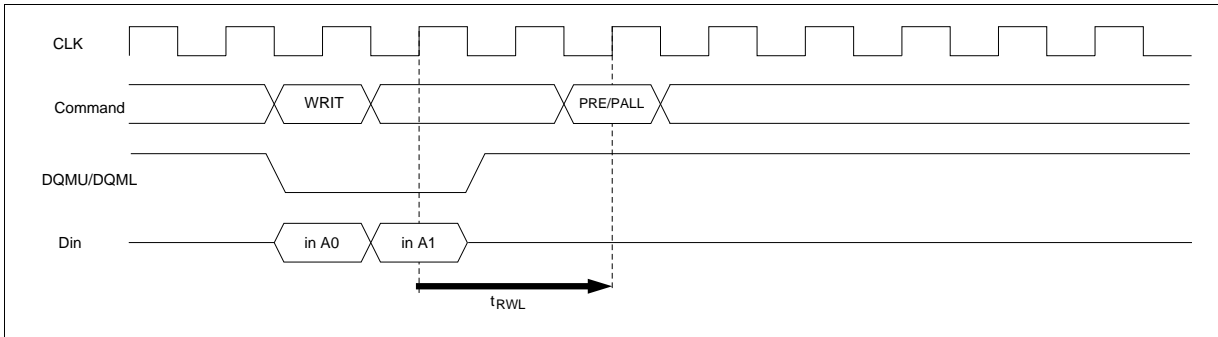
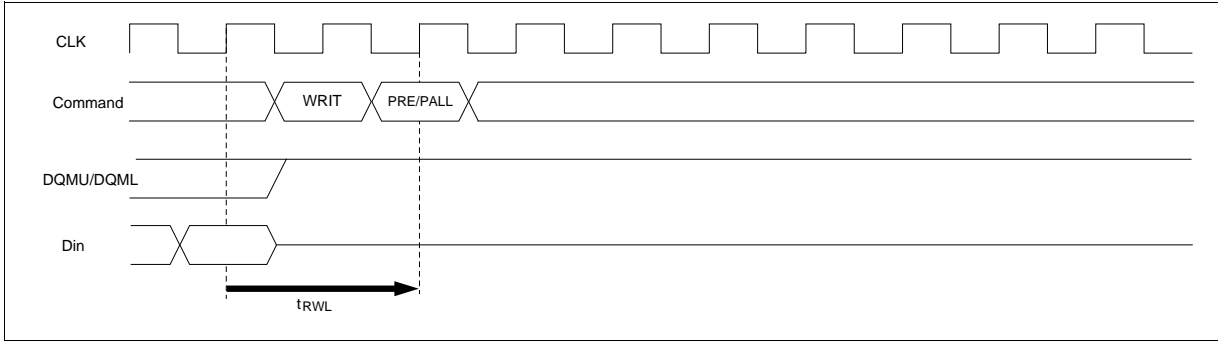

Burst Length = 4 (To write all data)

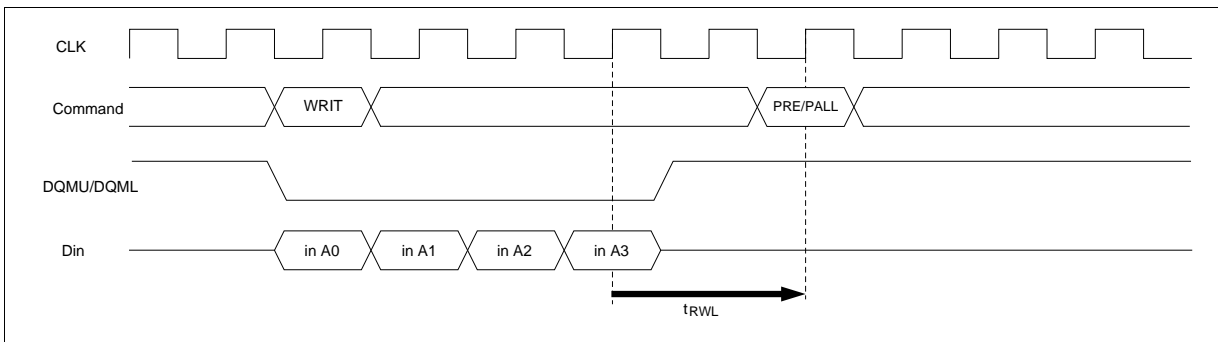

Bank active command interval

1. Same bank: The interval between the two bank-active commands must be no less than t_{RC} .

Bank active to bank active for same bank

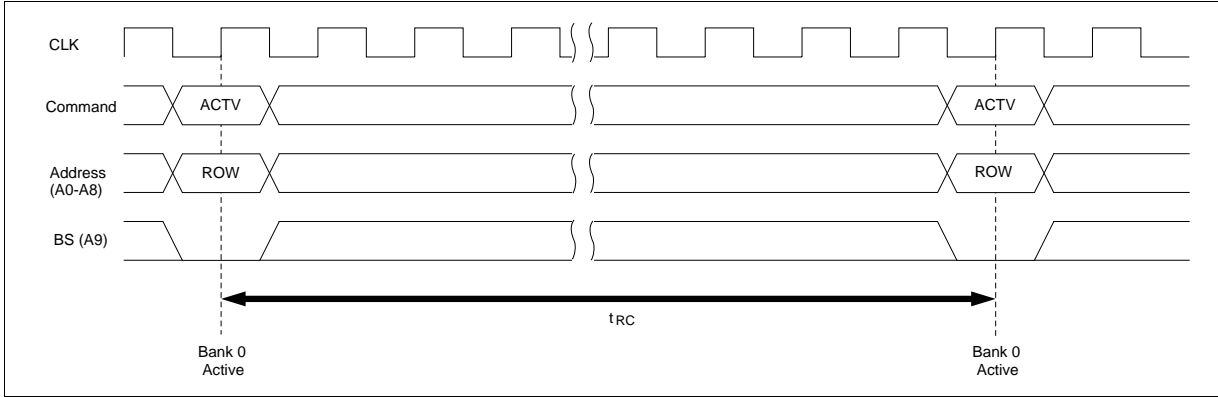

2. In the case of different bank-active commands: The interval between the two bank-active commands must be no less than t_{RRD} .

Bank active to bank active for different bank

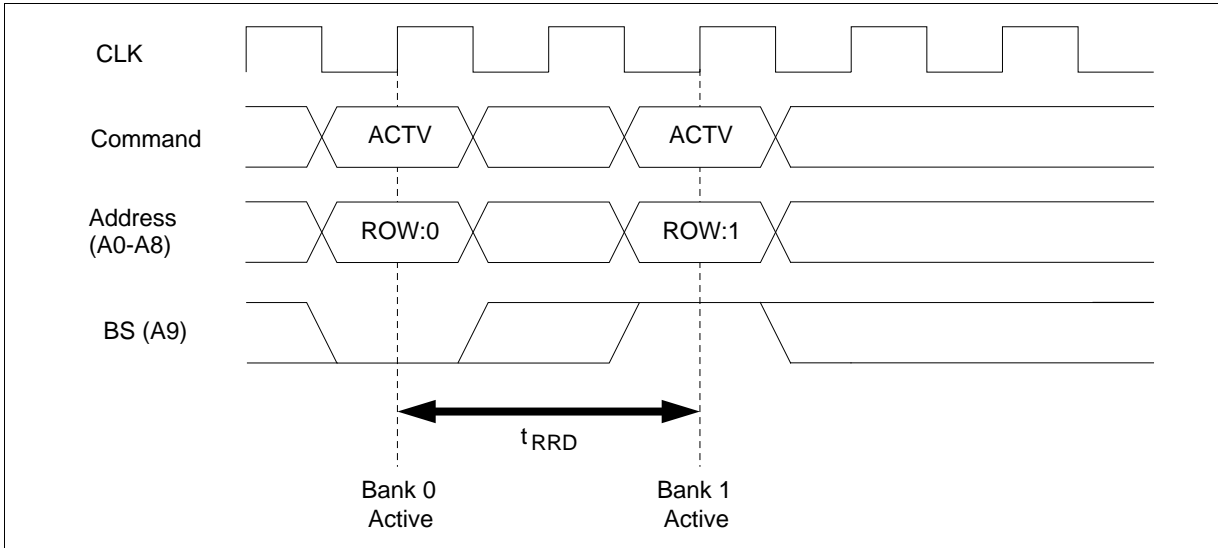

HM5241605C Series

Mode register set to Bank-active command interval: The interval between setting the mode register and executing a bank-active command must be no less than t_{RSA} .

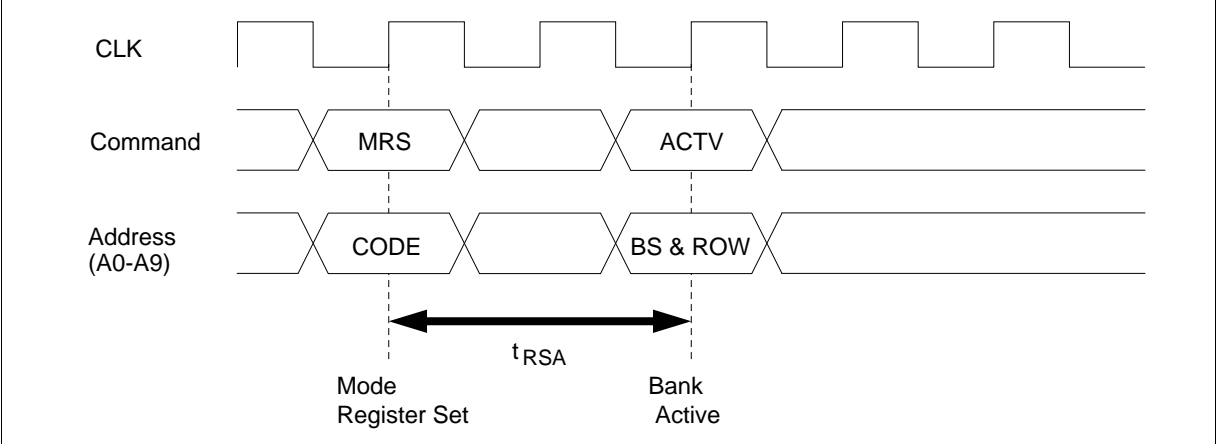

DQM Control

The DQMU and DQML mask the lower and upper bytes of the I/O data, respectively. The timing of DQMU/DQML is different during reading and writing.

Reading: When data is read, the output buffer can be controlled by DQMU/DQML. By setting DQMU/DQML to Low, the output buffer becomes Low-Z, enabling data output. By setting DQMU/DQML to High, the output buffer becomes High-Z, and the corresponding data is not output. However, internal reading operations continue. The latency of DQMU/DQML during reading is 2.

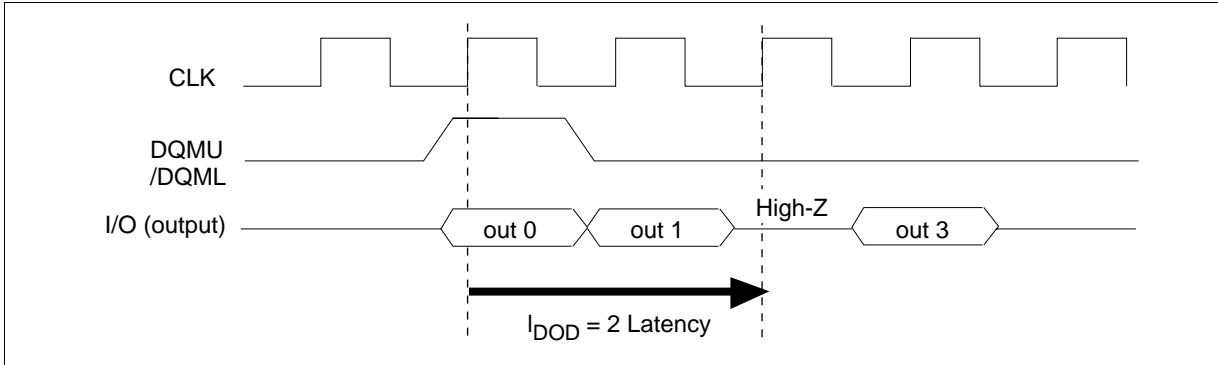

Writing: Input data can be masked by DQMU/DQML. By setting DQMU/DQML to Low, data can be written. In addition, when DQMU/DQML is set to High, the corresponding data is not written, and the previous data is held. The latency of DQMU/DQML during writing is 0.

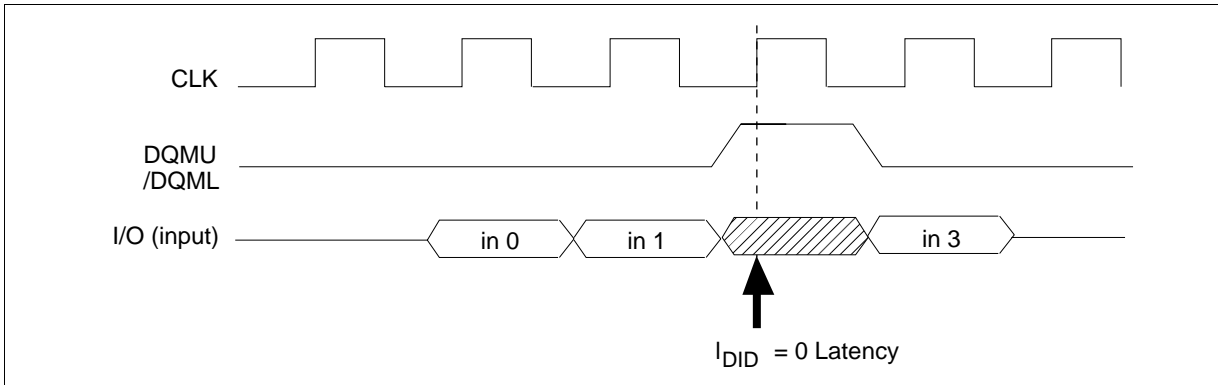

Refresh

Auto refresh: All the banks must be precharged before executing an auto refresh command. Since the auto refresh command updates the internal counter every time it is executed and determines the banks and the ROW addresses to be refreshed, external address specification is not required. The refresh cycle is 1,024 cycles/16 ms. (1,024 cycles are required to refresh all the ROW addresses.) The output buffer becomes High-Z after auto refresh start. In addition, since a precharge has been completed by an internal operation after the auto refresh, an additional precharge operation by the precharge command is not required.

Self refresh: After executing a self refresh command, the self refresh operation continues while CKE is held Low. During self refresh operation, all ROW addresses are refreshed by the internal refresh timer. A self refresh is terminated by a self refresh exit command. If you use distributed auto-refresh mode with 15.6 μ s interval in normal read/write cycle, auto-refresh should be executed within 15.6 μ s immediately after exiting from and before entering into self refresh mode. If you use address refresh or burst auto-refresh mode in normal read/write cycle, 1024 cycles of distributed auto-refresh with 15.6 μ s interval should be executed within 16 ms immediately from and before entering into self refresh mode.

Others

Power down mode: The synchronous DRAM enters power down mode when CKE goes Low in the IDLE state. In power down mode, power consumption is suppressed by deactivating the input initial circuit. Power down mode continues while CKE is held Low. In addition, by setting CKE to High, the synchronous DRAM exits from the power down mode, and command input is enabled from the next cycle. In this mode, internal refresh is not performed.

Clock suspend mode: By driving CKE to Low during a bank-active or read/write operation, the synchronous DRAM enters clock suspend mode. During clock suspend mode, external input signals are ignored and the internal state is maintained. When CKE is driven High, the synchronous DRAM terminates clock suspend mode, and command input is enabled from the next cycle. For details, refer to the "CKE Truth Table".

Power up sequence: HM5241605C series has two types of power up sequence. Hitachi recommends that the DQMU/DQML and the CKE are set to High to ensure output to be in the high impedance and to prevent from bus contention.

1. During power up sequence, the DQMU/DQML and the CKE must be set to High. When 100 μ s has past after power on, all banks must be precharged using the precharge command. After t_{RP} delay, set the mode register. And after t_{RSA} delay, execute two or more cycles of auto refresh operation as dummy, an interval of t_{RC} is required between two auto refresh commands.

2. During power up sequence, the DQMU/DQML and the CKE must be set to High. When 200 μ s has past after power on, all banks must be precharged using the precharge command. After t_{RP} delay, set 8 or more auto refresh commands. And set the mode register set command to initialize the mode register.

Absolute Maximum Ratings

Parameter	Symbol	Value	Unit	Notes
Voltage on any pin relative to V_{SS}	V_T	-1.0 to +5.5	V	1, 2
Supply voltage relative to V_{SS}	V_{CC}	-1.0 to +4.6	V	2
Short circuit output current	I_{out}	50	mA	
Power dissipation	P_T	1.0	W	
Operating temperature	T_{opr}	0 to +70	°C	
Storage temperature	T_{stg}	-55 to +125	°C	

Notes: 1. V_{IH} (max) = 5.75 V for pulse width \leq 5 ns.
 2. Respect to V_{SS} .

Recommended DC Operating Conditions ($T_a = 0$ to +70°C)

Parameter	Symbol	Min	Max	Unit	Notes
Supply voltage	$V_{CC}, V_{CC}Q$	3.0	3.6	V	1
	$V_{SS}, V_{SS}Q$	0	0	V	
Input high voltage	V_{IH}	2.0	5.5	V	1, 2
Input low voltage	V_{IL}	-0.3	0.8	V	1, 3

Notes: 1. All voltage referred to V_{SS}
 2. V_{IH} (max) = 5.75 V for pulse width \leq 5 ns
 3. V_{IL} (min) = -1.0 V for pulse width \leq 5 ns

HM5241605C Series

DC Characteristics ($T_a = 0$ to 70°C , V_{CC} , $V_{CC}Q = 3.3\text{ V} \pm 0.3\text{ V}$, V_{SS} , $V_{SS}Q = 0\text{ V}$)

		HM5241605C								
		-12		-15		-17				
Parameter	Symbol	Min	Max	Min	Max	Min	Max	Unit	Test conditions	Notes
Operating current	I_{CC1}	—	95	—	85	—	75	mA	Burst length = 1 $t_{RC} = \text{min}$	1, 2, 4
Standby current (Bank Disable)	I_{CC2}	—	3	—	3	—	3	mA	$\text{CKE} = V_{IL}$, $t_{CK} = \text{min}$	5
		—	2	—	2	—	2	mA	$\text{CKE} = V_{IL}$ $\text{CLK} = V_{IL}$ or V_{IH} Fixed	6
		—	39	—	33	—	30	mA	$\text{CKE} = V_{IH}$, NOP command, $t_{CK} = \text{min}$	3
Active standby current (Bank active)	I_{CC3}	—	7	—	7	—	7	mA	$\text{CKE} = V_{IL}$, $t_{CK} = \text{min}$, I/O = High-Z	1, 2
		—	40	—	34	—	31	mA	$\text{CKE} = V_{IH}$, NOP command $t_{CK} = \text{min}$, I/O = High-Z	1, 2, 3
Burst operating current (CL = 1)	I_{CC4}	—	65	—	65	—	60	mA	$t_{CK} = \text{min}$, BL = 4	1, 2, 4
		(CL = 2)	—	100	—	100	—	95	mA	
		(CL = 3)	—	120	—	105	—	95	mA	
Auto refresh current	I_{CC5}	—	85	—	70	—	65	mA	$t_{RC} = \text{min}$	
Self refresh current	I_{CC6}	—	2	—	2	—	2	mA	$V_{IH} \geq V_{CC} - 0.2$ $V_{IL} \leq 0.2\text{ V}$	7
Input leakage current	I_{LI}	-10	10	-10	10	-10	10	μA	$0 \leq V_{in} \leq V_{CC}$	
Output leakage current	I_{LO}	-10	10	-10	10	-10	10	μA	$0 \leq V_{out} \leq V_{CC}$ I/O = disable	
Output high voltage	V_{OH}	2.4	—	2.4	—	2.4	—	V	$I_{OH} = -2\text{ mA}$	
Output low voltage	V_{OL}	—	0.4	—	0.4	—	0.4	V	$I_{OL} = 2\text{ mA}$	

Notes: 1. I_{CC} depends on output load condition when the device is selected. I_{CC} (max) is specified at the output open condition.

2. One bank operation.
3. Input signal transition is once per two CLK cycles.
4. Input signal transition is once per one CLK cycle.
5. After power down mode set, CLK operating current.
6. After power down mode set, no CLK operating current.
7. After self refresh mode set, self refresh current.

Capacitance ($T_a = 25^\circ\text{C}$, V_{CC} , $V_{CC}Q = 3.3\text{ V} \pm 0.3\text{ V}$)

Parameter	Symbol	Typ	Max	Unit	Notes
Input capacitance (Address)	C_{I1}	—	5	pF	1, 3
Input capacitance (Signals)	C_{I2}	—	5	pF	1, 3
Output capacitance (I/O)	C_O	—	7	pF	1, 2, 3

- Notes: 1. Capacitance measured with Boonton Meter or effective capacitance measuring method.
 2. DQMU/DQML = V_{IH} to disable Dout.
 3. This parameter is sampled and not 100% tested.

AC Characteristics ($T_a = 0$ to 70°C , V_{CC} , $V_{CC}Q = 3.3\text{ V} \pm 0.3\text{ V}$, V_{SS} , $V_{SS}Q = 0\text{ V}$)

Parameter	Symbol	HM5241605C						Unit	Notes
		-12		-15		-17			
		Min	Max	Min	Max	Min	Max		
System clock cycle time (CL = 1)	t_{CK}	30	—	30	—	35	—	ns	1, 7
(CL = 2)	t_{CK}	15	—	15	—	17.5	—	ns	
(CL = 3)	t_{CK}	12.5 (12.0)	—	15	—	17.5	—	ns	
CLK high pulse width	t_{CKH}	4.5	—	6	—	7	—	ns	1
CLK low pulse width	t_{CKL}	4.5	—	6	—	7	—	ns	1
Access time from CLK (CL = 1)	t_{AC}	—	26	—	30	—	34	ns	1, 2
(CL = 2)	t_{AC}	—	13	—	15	—	16.5	ns	
(CL = 3)	t_{AC}	—	11	—	13	—	15.5	ns	
Read command to data valid time (CL = 1)	t_{ACK}	—	26	—	30	—	34	ns	1
(CL = 2)	t_{ACK}	—	28	—	30	—	34	ns	
(CL = 3)	t_{ACK}	—	36	—	43	—	50.5	ns	
Data-out hold time (CL = 1)	t_{OH}	4	—	4	—	4	—	ns	1, 2
(CL = 2, 3)	t_{OH}	3	—	3	—	3	—	ns	
CLK to Data-out low impedance	t_{LZ}	0	—	0	—	0	—	ns	1, 2
CLK to Data-out high impedance (CL = 1)	t_{HZ}	4	12	4	15	4	17	ns	1, 3
(CL = 2, 3)	t_{HZ}	3	9	3	10	3	12	ns	

HM5241605C Series

AC Characteristics ($T_a = 0$ to 70°C , $V_{CC}, V_{CCQ} = 3.3\text{ V} \pm 0.3\text{ V}$, $V_{SS}, V_{SSQ} = 0\text{ V}$) (cont.)

Parameter	Symbol	HM5241605C						Unit	Notes
		-12		-15		-17			
		Min	Max	Min	Max	Min	Max		
Data-in setup time	t_{DS}	3.5	—	4	—	4	—	ns	1
Data in hold time	t_{DH}	1.5	—	2	—	2	—	ns	1
Address setup time	t_{AS}	3.5	—	4	—	4	—	ns	1
Address hold time	t_{AH}	1.5	—	2	—	2	—	ns	1
CKE setup time	t_{CES}	3.5	—	4	—	4	—	ns	1, 4
CKE setup time for CKE function exit	t_{CESP}	8.5	—	13	—	15	—	ns	1, 5
CKE hold time	t_{CEH}	1.5	—	2	—	2	—	ns	1
CKE hold time for CKE function exit	t_{CEHP}	14	—	17	—	19.5	—	ns	1, 6
Command (\overline{CS} , \overline{RAS} , \overline{CAS} , \overline{WE} , DQM) setup time	t_{CS}	3.5	—	4	—	4	—	ns	1
Command (\overline{CS} , \overline{RAS} , \overline{CAS} , \overline{WE} , DQM) hold time	t_{CH}	1.5	—	2	—	2	—	ns	1
Ref/Active to Ref/Active command period	t_{RC}	110	—	110	—	120	—	ns	1
Active to precharge command period	t_{RAS}	70	10000	70	10000	75	10000	ns	1
Active to precharge on full page mode	t_{RASC}	—	80000	—	80000	—	80000	ns	1
Active command to column command (same bank)	t_{RCD}	30	—	30	—	35	—	ns	1
Precharge to active command period	t_{RP}	30	—	34	—	34	—	ns	1
The last data-in to Precharge lead time	t_{RWL}	25	—	30	—	35	—	ns	1
Active (a) to Active (b) command period	t_{RRD}	25	—	30	—	35	—	ns	1
Register set to active command	t_{RSA}	25	—	30	—	35	—	ns	1
Transition time (rise to fall)	t_T	1	5	1	5	1	5	ns	
Refresh period	t_{REF}	—	16	—	16	—	16	ms	

- Notes: 1. AC measurement assumes $t_T = 1\text{ ns}$. Reference level for timing of input signals is 1.40 V.
 2. Access time is measured at 1.40 V. Load condition is $C_L = 50\text{ pF}$ with current source.
 3. t_{HZ} (max) defines the time at which the outputs achieves $\pm 200\text{ mV}$. Load condition is $C_L = 5\text{ pF}$ with current source.
 4. t_{CES} define CKE setup time to CLK rising edge except power down exit command and active clock suspend exit command.
 5. t_{CESP} define CKE setup time to CLK rising edge for power down exit command and active clock suspend exit command.
 6. t_{CEHP} define CLK rising edge to CKE hold time for self refresh exit command, power down exit command and active clock suspend exit command.
 7. $t_{CK}\text{ min} = 12.0\text{ ns}$ (-12) is available under $V_{CC}\text{ min} = 3.15\text{ V}$.

Test Conditions

- Input and output timing reference levels: 1.4 V
- Input waveform and output load: See following figures.

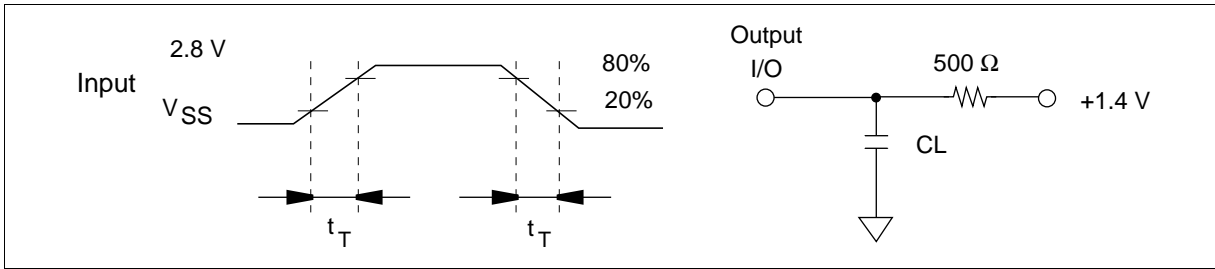

Relationship Between Frequency and Minimum Latency

Parameter	HM5241605C							Note
	-12		-15		-17			
	80	40	66	33	57	28.5		
Frequency (MHz)								
t_{CK} (ns)	Symbol	12.5	25	15	30	17.5	35	
Active command to column command (same bank)	t _{RCD}	3	2	2	1	2	1	1
Active command to active command (same bank)	t _{RC}	9	5	8	5	7	4	1, = [t _{RAS} + t _{RP}]
Active command to precharge command (same bank)	t _{RAS}	6	3	5	3	5	3	1
Precharge command to active command (same bank)	t _{RP}	3	2	3	2	2	1	1
Last data input to precharge command (same bank)	t _{RWL}	2	1	2	1	2	1	1
Active command to active command (different bank)	t _{RRD}	2	1	2	1	2	1	1
Last data in to active command (auto precharge, same bank)	t _{APW}	5	3	5	3	4	2	= [t _{RWL} + t _{RP}]
Self refresh exit to command input	t _{SEC}	9	5	8	4	7	4	= [t _{RC}]
Precharge command to high impedance (CAS latency = 1)	t _{HZP}	—	—	—	1	—	1	
(CAS latency = 2)	t _{HZP}	—	2	2	2	2	2	
(CAS latency = 3)	t _{HZP}	3	3	3	3	3	3	
Last data out to active command (auto precharge, same bank) (CAS latency = 1)	t _{APR}	—	—	—	2	—	1	= [t _{RP}]
(CAS latency = 2)	t _{APR}	2	1	2	1	—	1	= [t _{RP}] - 1
(CAS latency = 3)	t _{APR}	2	1	2	1	1	0	= [t _{RP}] - 1

HM5241605C Series

Parameter	HM5241605C							
		-12		-15		-17		
	Frequency (MHz)	80	40	66	33	57	28.5	
t_{CK} (ns)	Symbol	12.5	25	15	30	17.5	35	Note
Last data out to precharge (early precharge)								
(CAS latency = 1)	I_{EP}	—	—	—	0	—	0	
(\overline{CAS} latency = 2)	I_{EP}	-1	-1	-1	-1	-1	-1	
(\overline{CAS} latency = 3)	I_{EP}	-2	-2	-2	-2	-2	-2	
Column command to column command	I_{CCD}	1	1	1	1	1	1	
Write command to data in latency	I_{WCD}	0	0	0	0	0	0	
DQM to data in	I_{DID}	0	0	0	0	0	0	
DQM to data out	I_{DOD}	2	2	2	2	2	2	
CKE to CLK disable	I_{CLE}	1	1	1	1	1	1	
Register set to active command	t_{RSA}	2	1	2	1	2	1	
CS to command disable	I_{CDD}	0	0	0	0	0	0	
Power down exit to command input	I_{PEC}	1	1	1	1	1	1	
Burst stop to output valid data hold								
(CAS latency = 1)	I_{BSR}	—	—	—	0	—	0	
(\overline{CAS} latency = 2)	I_{BSR}	1	1	1	1	1	1	
(\overline{CAS} latency = 3)	I_{BSR}	2	2	2	2	2	2	
Burst stop to output high impedance								
(CAS latency = 1)	I_{BSH}	—	—	—	1	—	1	
(\overline{CAS} latency = 2)	I_{BSH}	2	2	2	2	2	2	
(\overline{CAS} latency = 3)	I_{BSH}	3	3	3	3	3	3	
Burst stop to write data ignore	I_{BSW}	1	1	1	1	1	1	

Note: 1. t_{RCD} to t_{RRD} are recommended value.

Timing Waveforms

Read Cycle

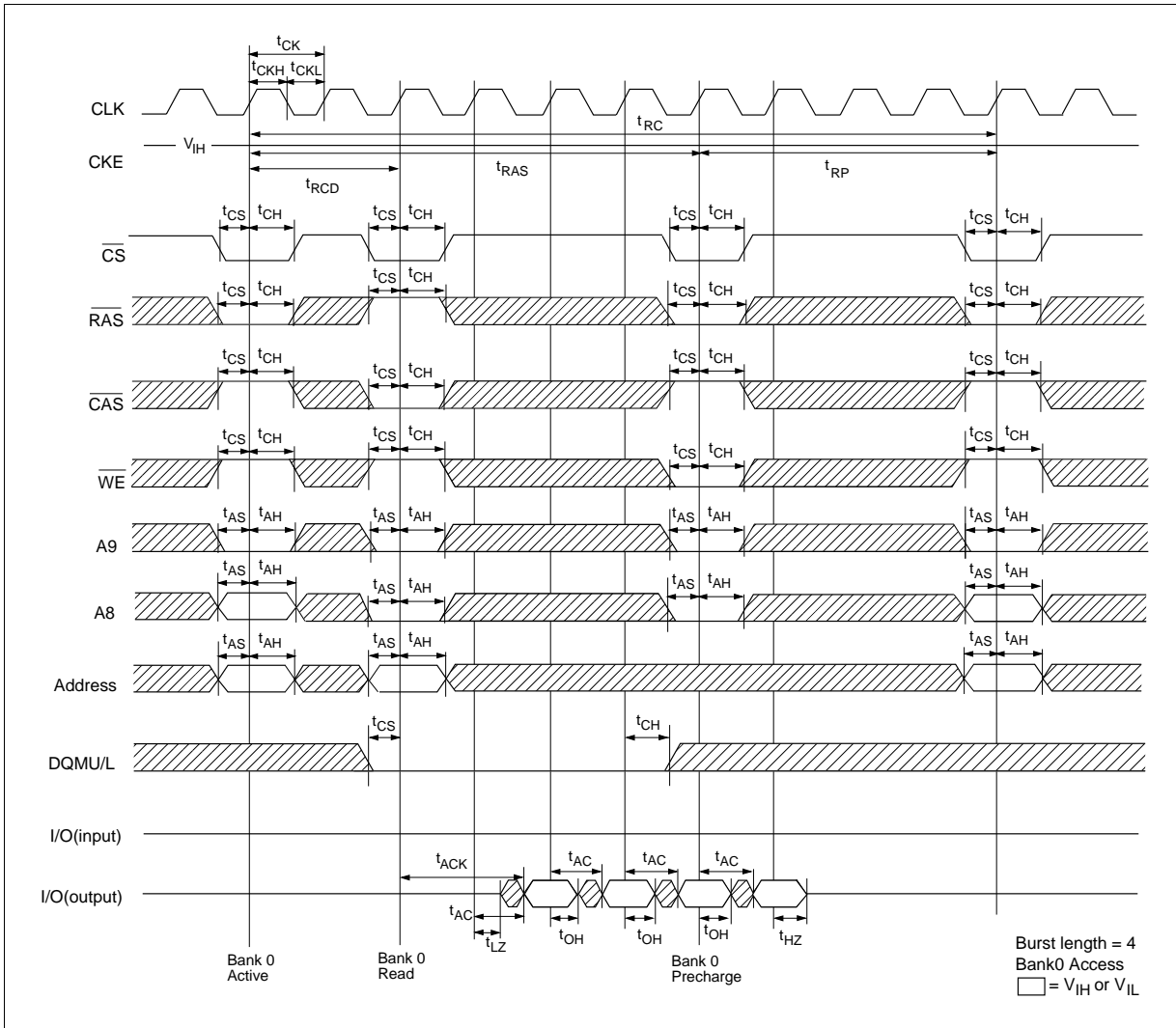

Write Cycle

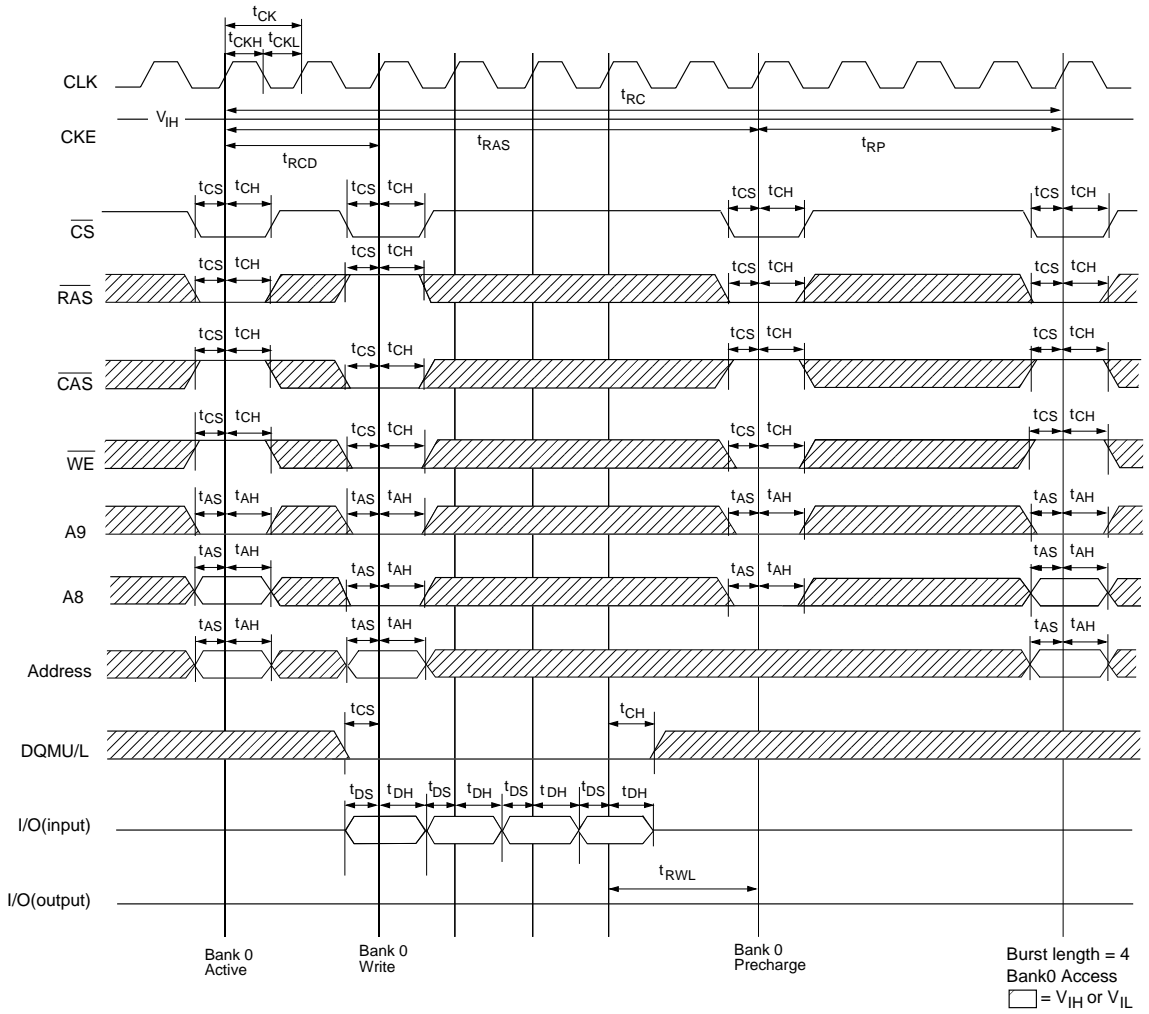

Mode Register Set Cycle

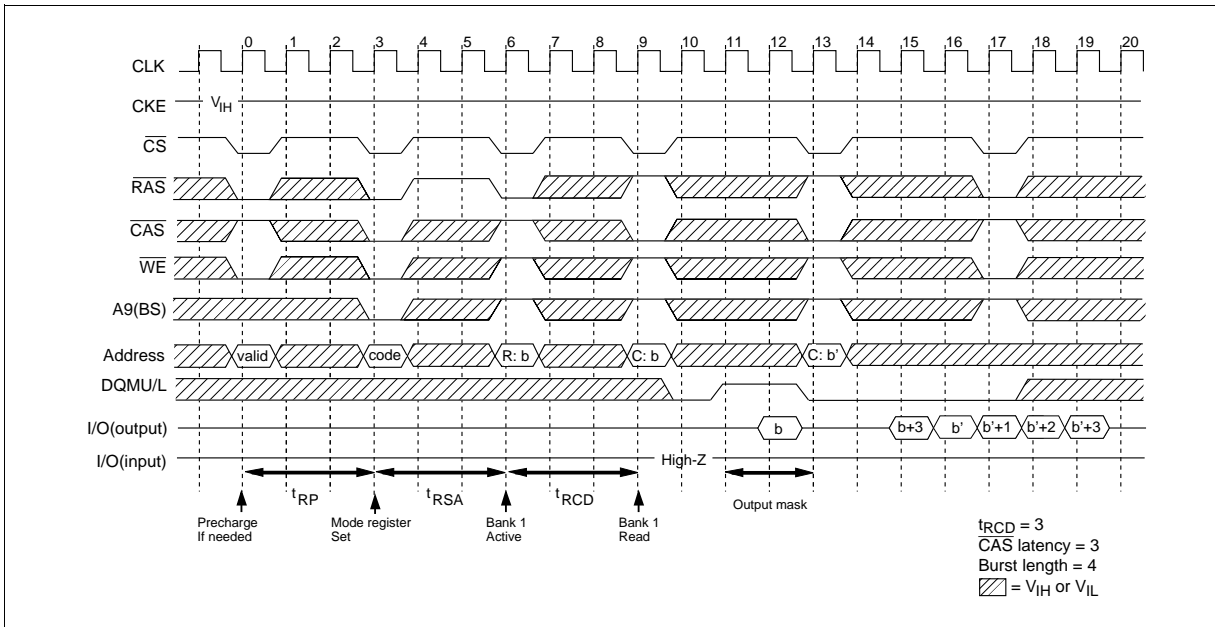

Read Cycle/Write Cycle

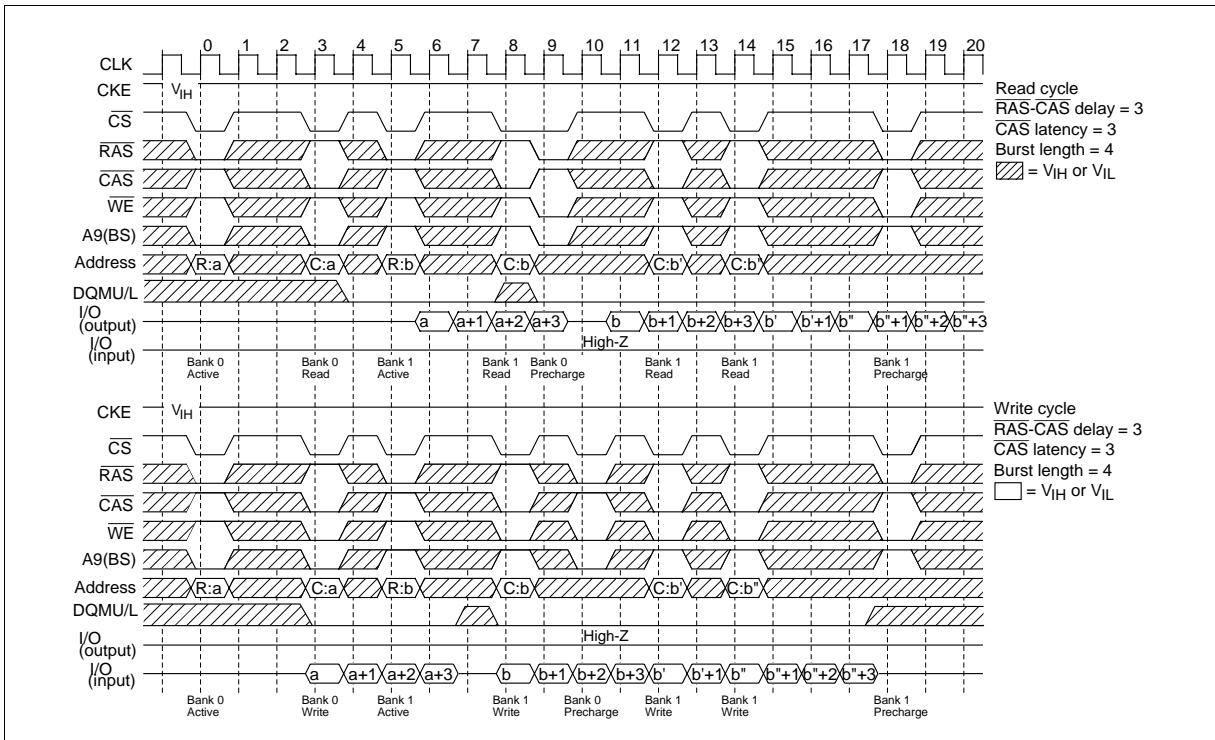

Read/Single Write Cycle

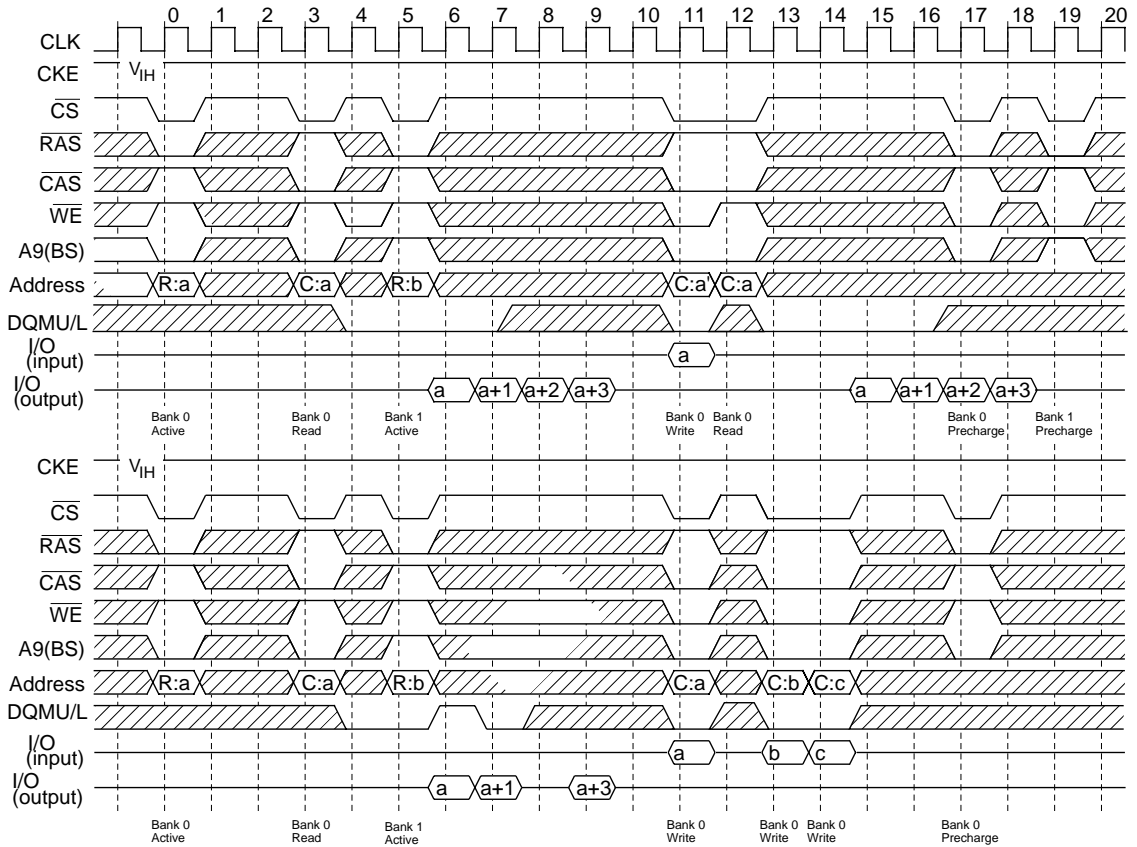

Read/Single write
 RAS-CAS delay = 3
 CAS latency = 3
 Burst length = 4
 ▨ = V_{IH} or V_{IL}

Read/Burst Write Cycle

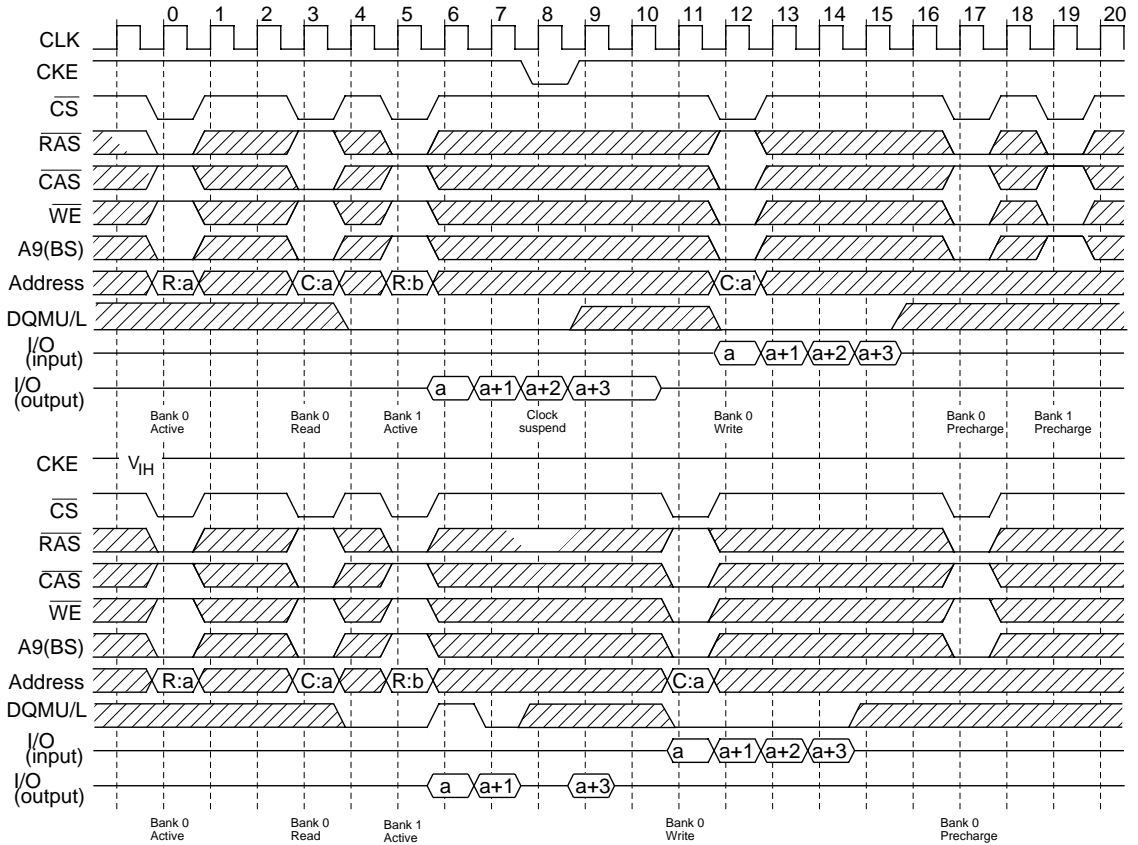

Read/Burst write
 RAS-CAS delay = 3
 CAS latency = 3
 Burst length = 4
 □ = V_{IH} or V_{IL}

Full Page Read/Write Cycle

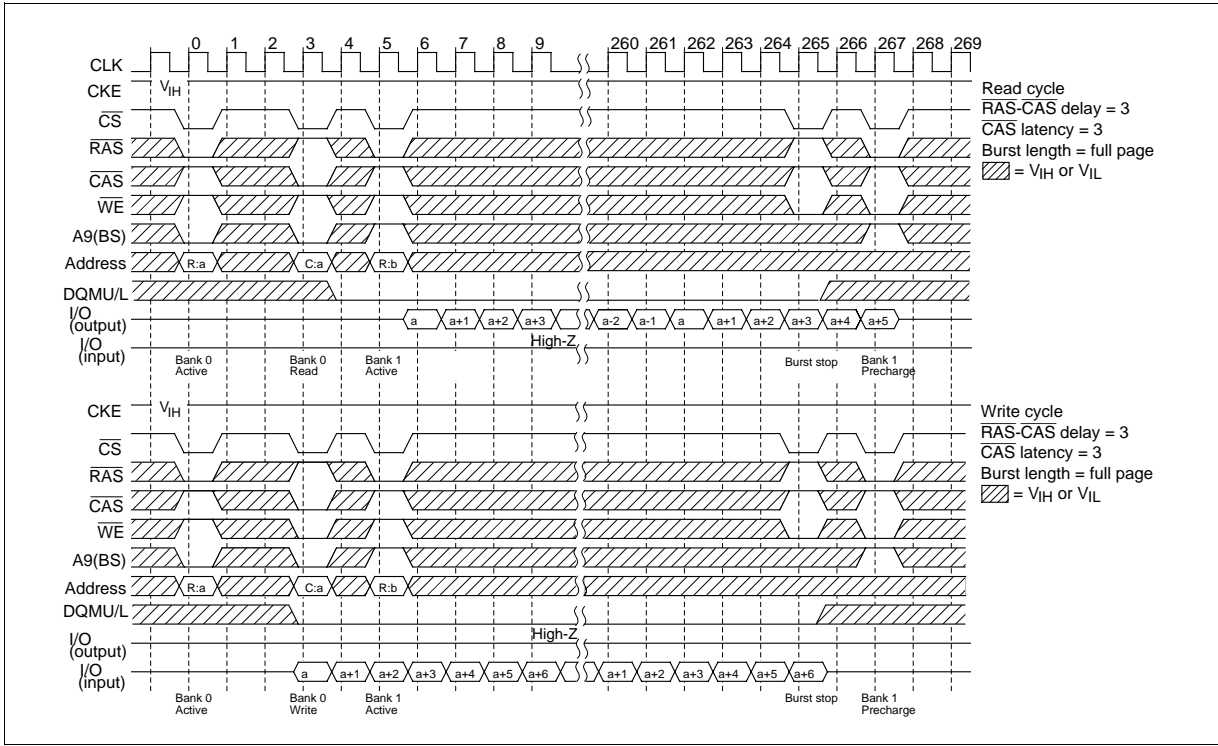

Auto Refresh Cycle

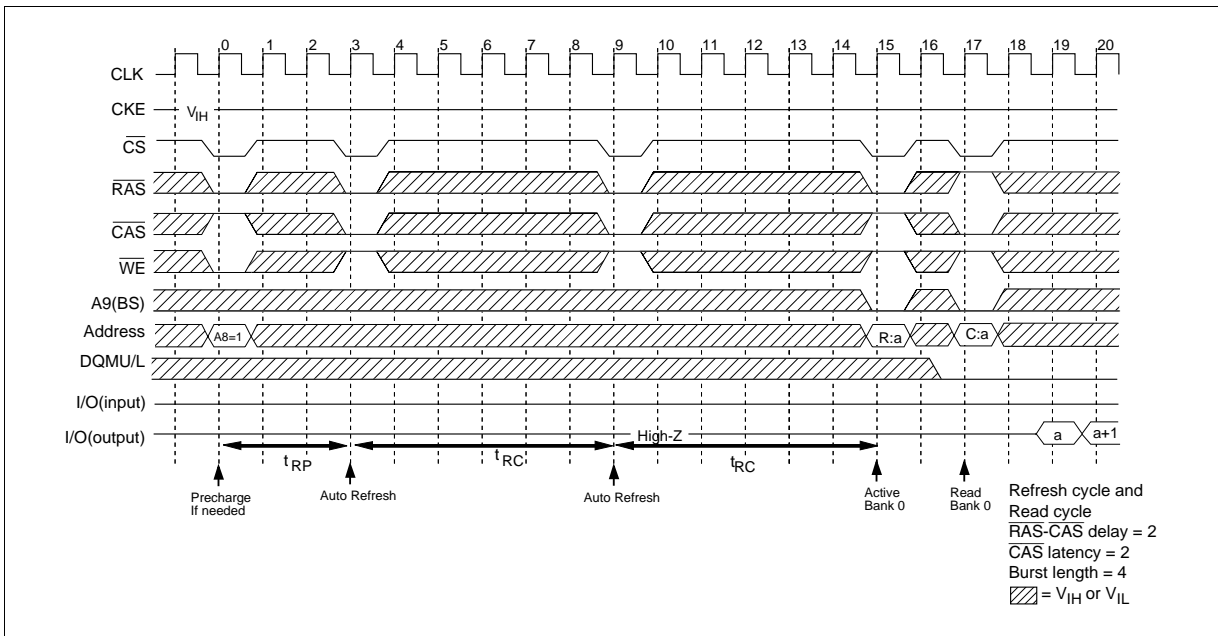

Self Refresh Cycle

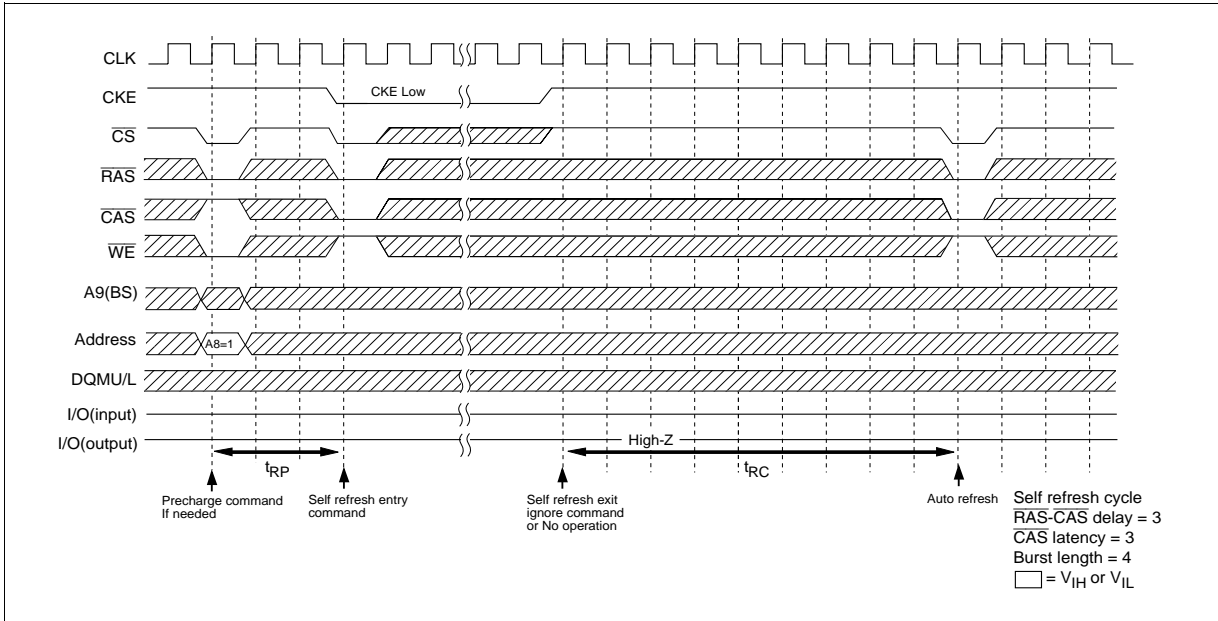

Clock Suspend Mode

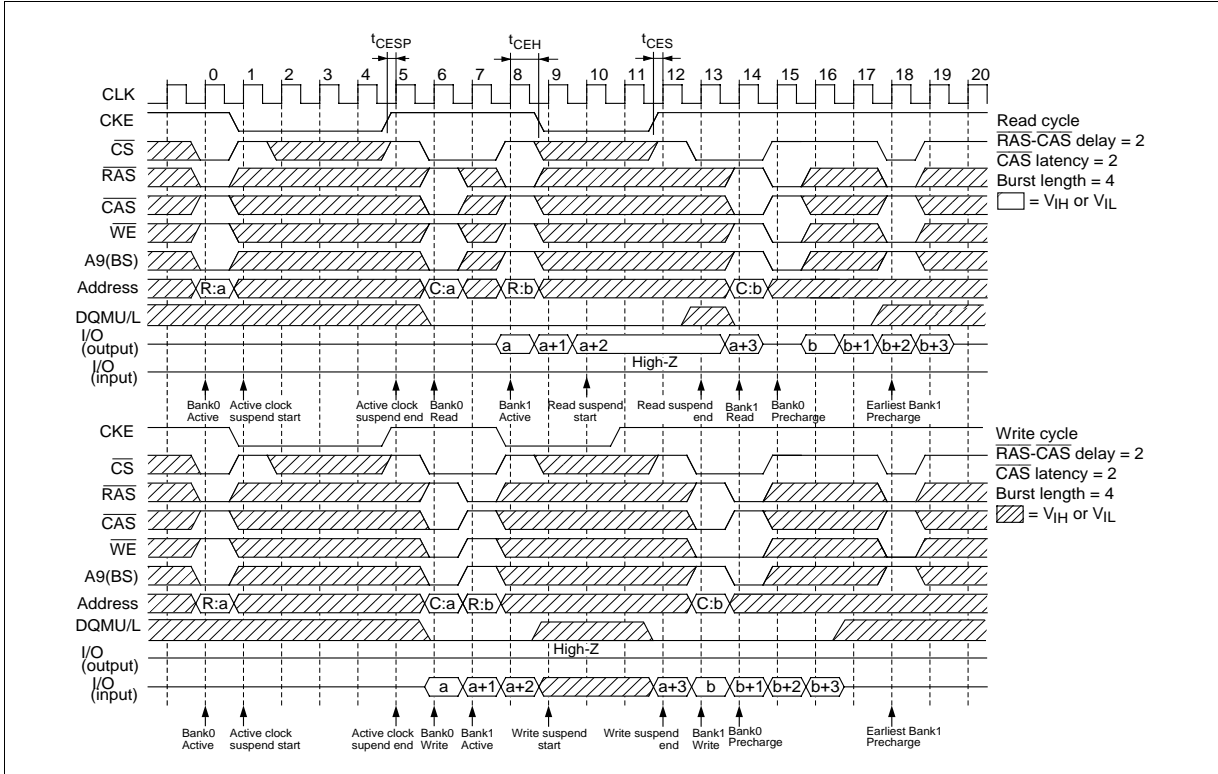

Power Down Mode

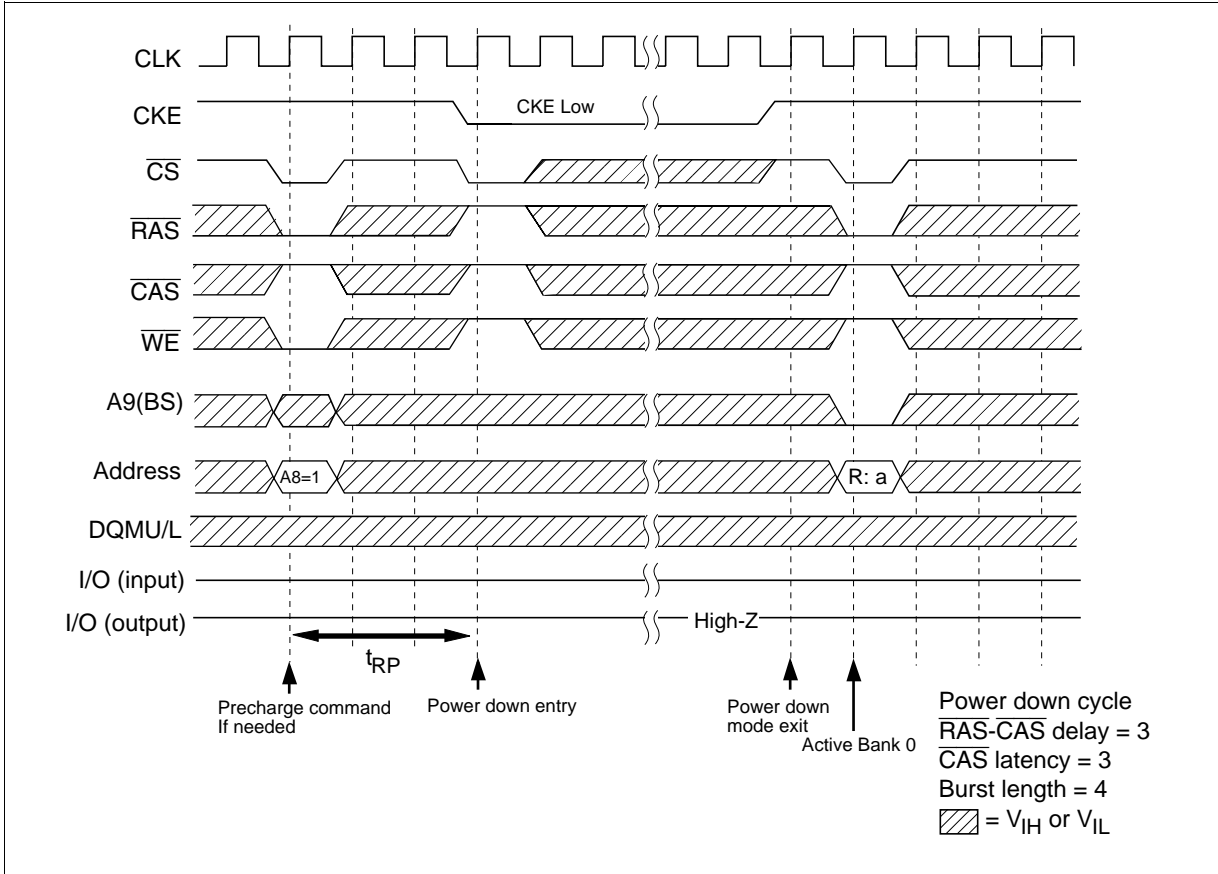

Power Up Sequence (1)

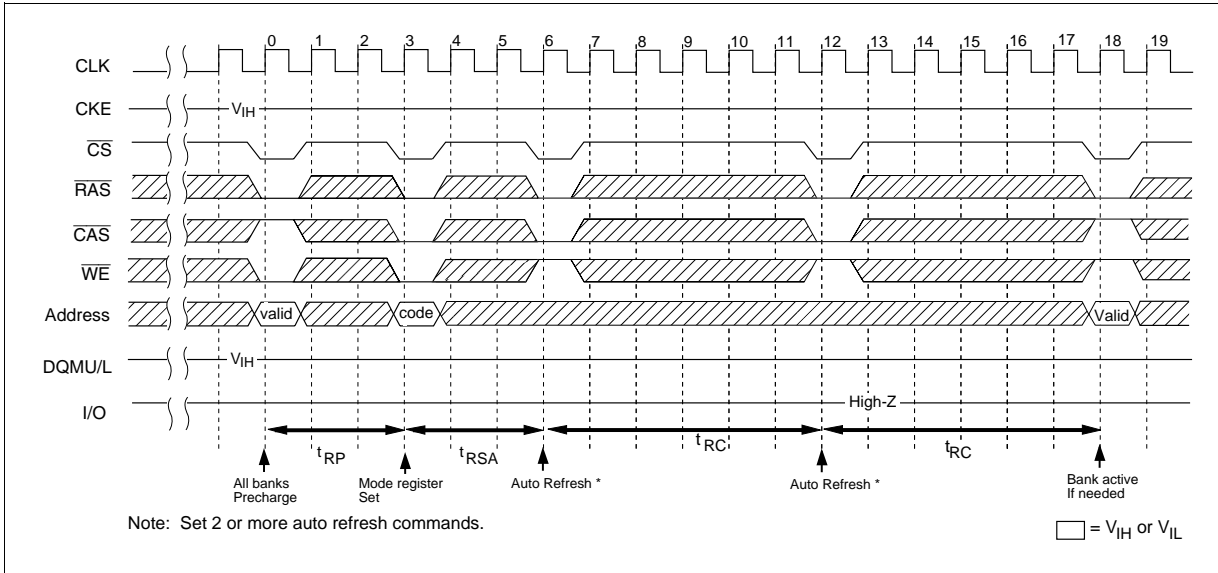

Power Up Sequence (2)

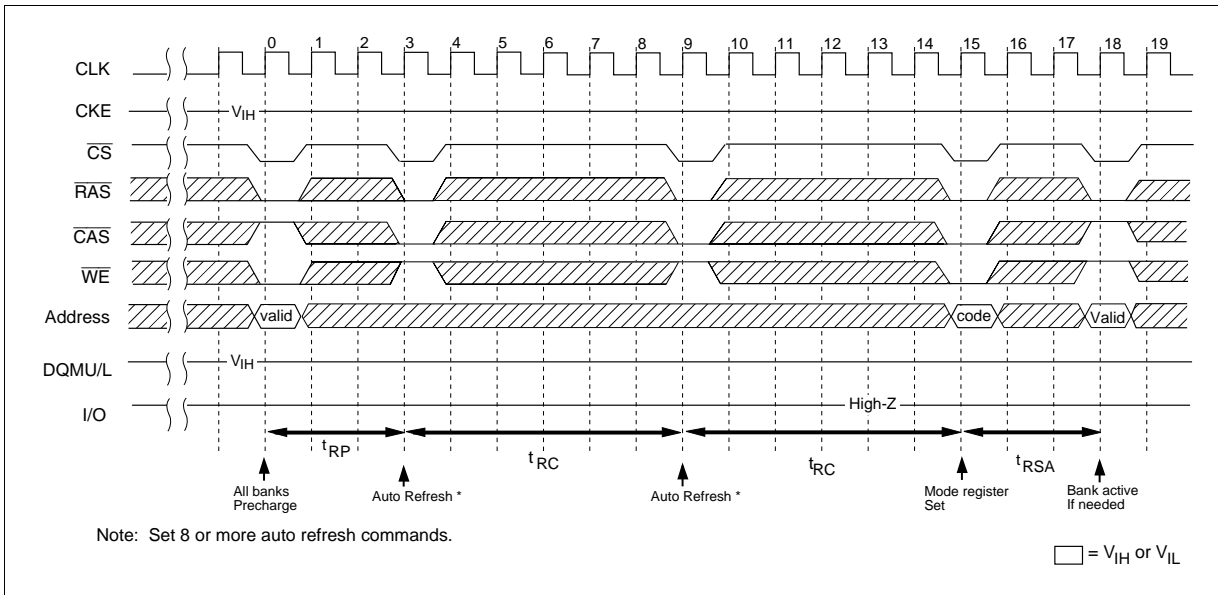

When using this document, keep the following in mind:

1. This document may, wholly or partially, be subject to change without notice.
2. All rights are reserved: No one is permitted to reproduce or duplicate, in any form, the whole or part of this document without Hitachi's permission.
3. Hitachi will not be held responsible for any damage to the user that may result from accidents or any other reasons during operation of the user's unit according to this document.
4. Circuitry and other examples described herein are meant merely to indicate the characteristics and performance of Hitachi's semiconductor products. Hitachi assumes no responsibility for any intellectual property claims or other problems that may result from applications based on the examples described herein.
5. No license is granted by implication or otherwise under any patents or other rights of any third party or Hitachi, Ltd.
6. **MEDICAL APPLICATIONS:** Hitachi's products are not authorized for use in **MEDICAL APPLICATIONS** without the written consent of the appropriate officer of Hitachi's sales company. Such use includes, but is not limited to, use in life support systems. Buyers of Hitachi's products are requested to notify the relevant Hitachi sales offices when planning to use the products in **MEDICAL APPLICATIONS**.

HITACHI

Hitachi, Ltd.

Semiconductor & IC Div.
Nippon Bldg., 2-6-2, Ohte-machi, Chiyoda-ku, Tokyo 100, Japan
Tel: Tokyo (03) 3270-2111
Fax: (03) 3270-5109

For further information write to:

Hitachi America, Ltd.
Semiconductor & IC Div.
2000 Sierra Point Parkway
Brisbane, CA. 94005-1835
U S A
Tel: 415-589-8300
Fax: 415-583-4207

Hitachi Europe GmbH
Electronic Components Group
Continental Europe
Dornacher Straße 3
D-85622 Feldkirchen
München
Tel: 089-9 91 80-0
Fax: 089-9 29 30 00

Hitachi Europe Ltd.
Electronic Components Div.
Northern Europe Headquarters
Whitebrook Park
Lower Cookham Road
Maidenhead
Berkshire SL6 8YA
United Kingdom
Tel: 0628-585000
Fax: 0628-778322

Hitachi Asia Pte. Ltd.
16 Collyer Quay #20-00
Hitachi Tower
Singapore 0104
Tel: 535-2100
Fax: 535-1533

Hitachi Asia (Hong Kong) Ltd.
Unit 706, North Tower,
World Finance Centre,
Harbour City, Canton Road
Tsim Sha Tsui, Kowloon
Hong Kong
Tel: 27359218
Fax: 27306071

Revision Record

Rev.	Date	Contents of Modification	Drawn by	Approved by
0.0	Apr. 17, 1995	Initial issue	S. Ishikawa	T. Kizaki
1.0	May. 22, 1996	Command Operation Change of Command Truth Table and CKE Truth Table Absolute Maximum Ratings Addition of notes 2 AC Characteristic Addition of t_{CEHP} min: 14/17/19.5 ns t_{RAS} min: 70/70/80 ns to 70/70/75 ns Addition of notes 5, 6 and 7 Relationship Between Frequency and Minimum Latency I_{SEC} : 9/5/8/5/7/4 to 9/5/8/4/7/4 Deletion of notes 2 Timing Waveforms Change of Clock Suspend Mode Addition of note for Power Up Sequence	M. Sakamoto	T. Kizaki
2.0	Jan. 7, 1997	Features Addition of Clock frequency: 83 MHz (V_{CC} min = 3.15 V) AC Characteristics Addition of notes 7		