HN58C66 Series

8192-word \times 8-bit CMOS Electrically Erasable and Programmable
CMOS ROM

HITACHI

ADE-203-375F (Z)

Rev. 6.0

Apr. 12, 1995

Description

The Hitachi HN58C66 is a electrically erasable and programmable ROM organized as 8192-word \times 8-bit. It realizes high speed, low power consumption, and a high level of reliability, employing advanced MNOS memory technology and CMOS process and circuitry technology. It also has a 32-byte page programming function to make its erase and write operations faster.

Features

- Single 5 V supply
- On chip latches: address, data, $\overline{\text{CE}}$, $\overline{\text{OE}}$, $\overline{\text{WE}}$
- Automatic byte write: 10 ms max
- Automatic page write (32 bytes): 10 ms max
- High speed: Access time 250 ns max
- Low power dissipation:
20 mW/MHz typ (active)
2.0 mW typ (standby)
- $\overline{\text{Data}}$ polling, $\overline{\text{RDY}}$ / $\overline{\text{Busy}}$
- Data protection circuit on power on/off
- Conforms to JEDEC byte-wide standard
- Reliable CMOS with MNOS cell technology
- 10^5 erase/write cycles (in page mode)
- 10 years data retention
- Write protection by $\overline{\text{RES}}$ pin

HN58C66 Series

Ordering Information

Type No	Access Time	Package
HN58C66P-25	250 ns	600-mil 28-pin plastic DIP (DP-28)
HN58C66FP-25	250 ns	28-pin plastic SOP ¹ (FP-28D/DA)
HN58C66T-25	250 ns	32-pin plastic TSOP (TFP-32DA)

Note: 1. T is added to the end of the type no. for a SOP of 3.00 mm (max) thickness.

Pin Arrangement

HN58C66P/FP Series

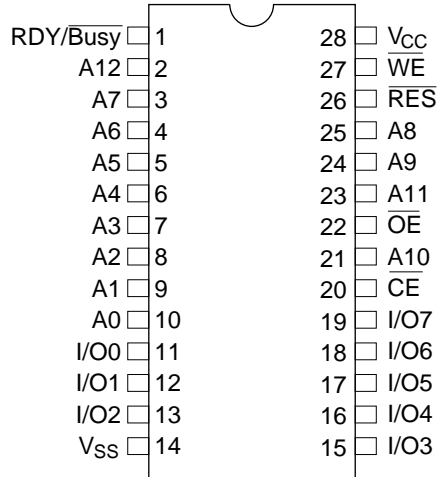

(Top View)

HN58C66T Series

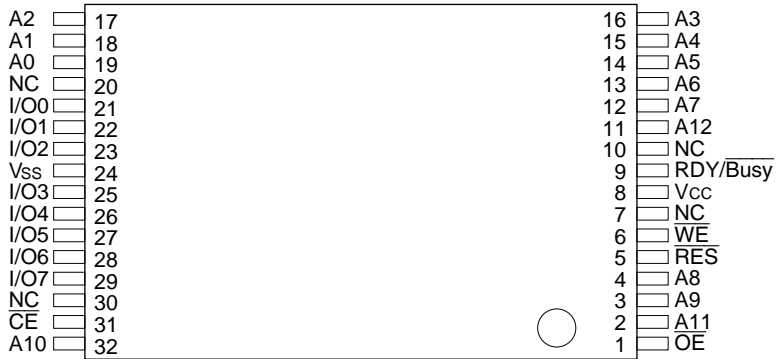

(Top View)

HN58C66 Series

Pin Description

Pin Name	Function
A0 – A12	Address
I/O0 – I/O7	Data input/output
\overline{OE}	Output enable
\overline{CE}	Chip enable
\overline{WE}	Write enable
V_{CC}	Power supply (+5 V)
V_{SS}	Ground
\overline{RES}	Reset
NC	No connection
RDY/\overline{Busy}	Ready/Busy

Block Diagram

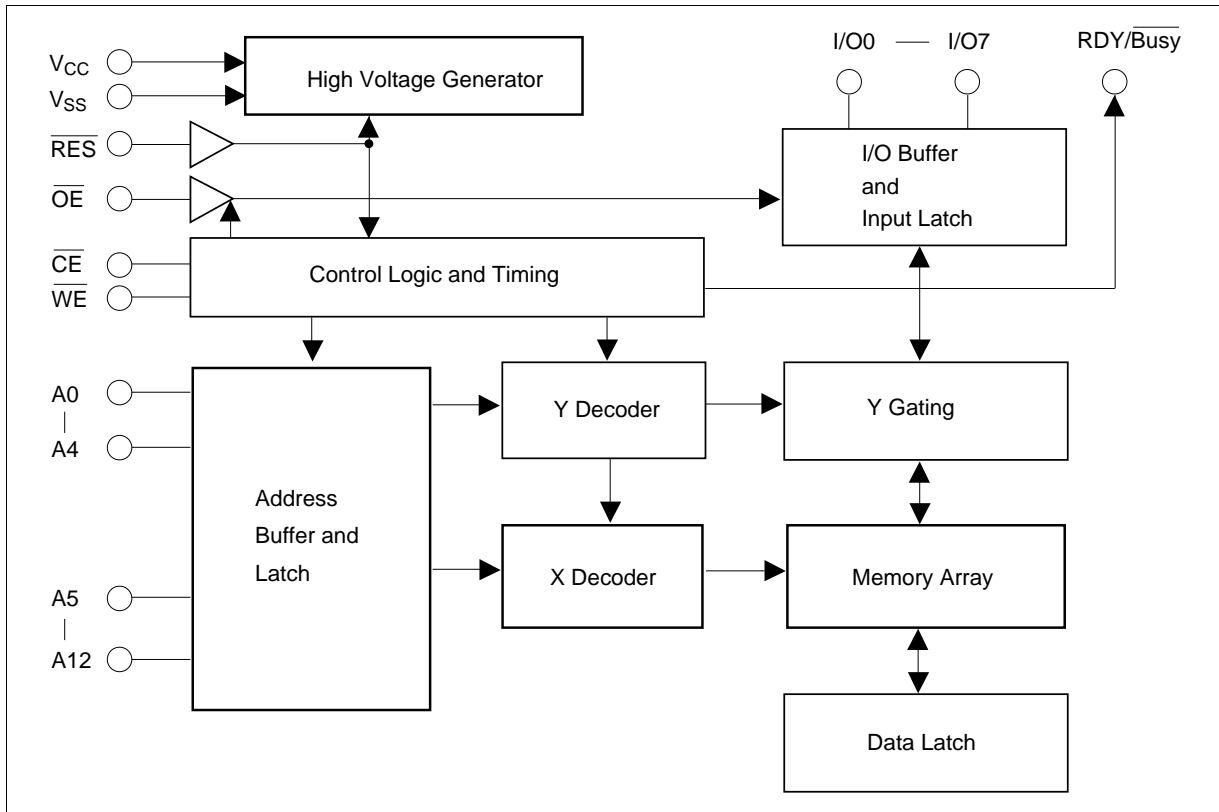

Mode Selection

Pin Mode	\overline{CE}	\overline{OE}	\overline{WE}	$\overline{RDY/Busy}$	\overline{RES}	I/O
Read	V_{IL}	V_{IL}	V_{IH}	High-Z	V_H^{*1}	Dout
Standby	V_{IH}	X ^{*2}	X	High-Z	X	High-Z
Write	V_{IL}	V_{IH}	V_{IL}	High-Z to V_{OL}	V_H	Din
Deselect	V_{IL}	V_{IH}	V_{IH}	High-Z	V_H	High-Z
Write inhibit	X	X	V_{IH}	High-Z	X	—
	X	V_{IL}	X			
Data polling	V_{IL}	V_{IL}	V_{IH}	V_{OL}	V_H	Data out (I/O7)
Program reset	X	X	X	High-Z	V_{IL}	High-Z

- Notes: 1. Refer to the recommended DC operating condition.
 2. X = Don't care.

Absolute Maximum Ratings

Parameter	Symbol	Value	Unit
Supply voltage ^{*1}	V_{CC}	-0.6 to +7.0	V
Input voltage ^{*1}	V_{in}	-0.5 ^{*2} to +7.0	V
Operating temperature range ^{*3}	T_{opr}	0 to +70	°C
Storage temperature range	T_{stg}	-55 to +125	°C

- Notes: 1. With respect to V_{SS}
 2. $V_{in\ min} = -3.0\ V$ for pulse width $\leq 50\ ns$
 3. Including electrical characteristics and data retention

Recommended DC Operating Conditions

Parameter	Symbol	Min	Typ	Max	Unit
Supply voltage	V_{CC}	4.5	5.0	5.5	V
Input voltage	V_{IL}	-0.3	—	0.8	V
	V_{IH}	2.2	—	$V_{CC} + 1.0$	V
	V_H	$V_{CC} - 0.5$	—	$V_{CC} + 1.0$	V
Operating temperature	T_{opr}	0	—	70	°C

HN58C66 Series

DC Characteristics (Ta = 0 to +70°C, V_{CC} = 5 V ± 10%)

Parameter	Symbol	Min	Typ	Max	Unit	Test Conditions
Input leakage current	I _{LI}	—	—	2 ^{*1}	μA	V _{CC} = 5.5 V, V _{in} = 5.5 V
Output leakage current	I _{LO}	—	—	2	μA	V _{CC} = 5.5 V, V _{out} = 5.5/0.4 V
V _{CC} current (standby)	I _{CC1}	—	—	1	mA	$\overline{CE} = V_{IH}, \overline{CE} = V_{CC}$
V _{CC} current (active)	I _{CC2}	—	—	8	mA	I _{out} = 0 mA, Duty = 100%, Cycle = 1 μs at V _{CC} = 5.5 V
				—	—	25
Input low voltage	V _{IL}	-0.3 ^{*2}	—	0.8	V	
Input high voltage	V _{IH}	2.2	—	V _{CC} + 1.0	V	
	V _H	V _{CC} - 0.5	—	V _{CC} + 1.0	V	
Output low voltage	V _{OL}	—	—	0.4	V	I _{OL} = 2.1 mA
Output high voltage	V _{OH}	2.4	—	—	V	I _{OH} = -400 μA

Notes: 1. I_{LI} on \overline{RES} = 100 μA max.

2. V_{IL} min = -1.0 V for pulse width ≤ 50 ns

Capacitance (Ta = 25°C, f = 1 MHz)

Parameter	Symbol	Min	Typ	Max	Unit	Test Conditions
Input capacitance	C _{in} ^{*1}	—	—	6	pF	V _{in} = 0 V
Output capacitance	C _{out} ^{*1}	—	—	12	pF	V _{out} = 0 V

Note: 1. This parameter is periodically sampled and not 100% tested.

AC Characteristics (Ta = 0 to +70°C, V_{CC} = 5 V ± 10%)

Test Conditions

- Input pulse levels: 0.4 V to 2.4 V, 0 to V_{CC} (\overline{RES} pin)
- Input rise and fall time: ≤ 20 ns
- Output load: 1TTL gate +100 pF
- Reference levels for measuring timing: 0.8 V, 2.0 V

Read Cycle

Parameter	Symbol	Min	Max	Unit	Test Conditions
Address to output delay	t_{ACC}	—	250	ns	$\overline{CE} = \overline{OE} = V_{IL}, \overline{WE} = V_{IH}$
\overline{CE} to output delay	t_{CE}	—	250	ns	$\overline{OE} = V_{IL}, \overline{WE} = V_{IH}$
\overline{OE} to output delay	t_{OE}	10	100	ns	$\overline{CE} = V_{IL}, \overline{WE} = V_{IH}$
\overline{OE} (\overline{CE}) high to output float ^{*1}	t_{DF}	0	90	ns	$\overline{CE} = V_{IL}, \overline{WE} = V_{IH}$
\overline{RES} low to output float ^{*1}	t_{DFR}	0	350	ns	$\overline{CE} = \overline{OE} = V_{IL}, \overline{WE} = V_{IH}$
Data output hold	t_{OH}	0	—	ns	$\overline{CE} = \overline{OE} = V_{IL}, \overline{WE} = V_{IH}$
\overline{RES} to output delay	t_{RR}	0	450	ns	$\overline{CE} = \overline{OE} = V_{IL}, \overline{WE} = V_{IH}$

Note: 1. t_{DF}, t_{DFR} is defined at which the outputs achieve the open circuit conditions and are no longer driven.

Read Timing Waveform

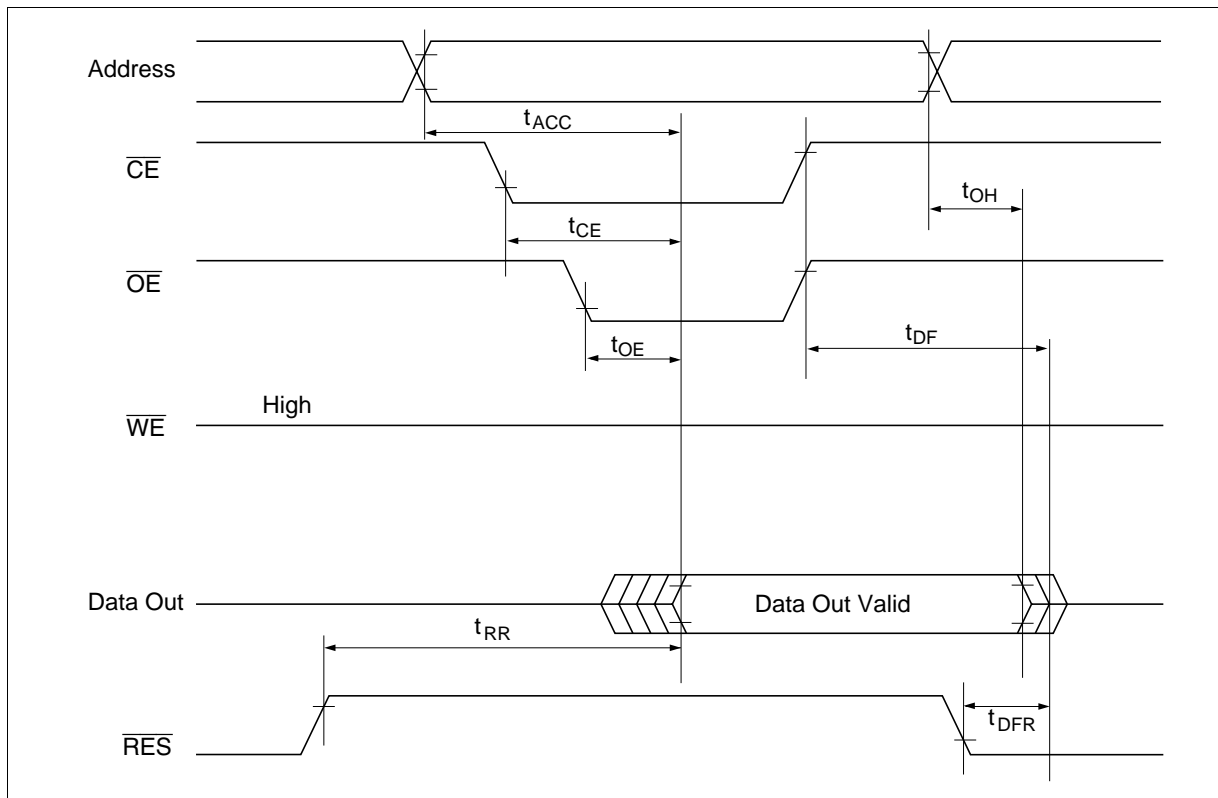

HN58C66 Series

Write Cycle

Parameter	Symbol	Min ¹	Typ	Max	Unit	Test Conditions
Address setup time	t_{AS}	0	—	—	ns	
Address hold time	t_{AH}	150	—	—	ns	
\overline{CE} to write setup time (\overline{WE} controlled)	t_{CH}	0	—	—	ns	
\overline{CE} hold time (\overline{WE} controlled)	t_{CH}	0	—	—	ns	
\overline{WE} to write setup time (\overline{CE} controlled)	t_{WS}	0	—	—	ns	
\overline{WE} hold time (\overline{CE} controlled)	t_{WH}	0	—	—	ns	
\overline{OE} to write setup time	t_{OES}	0	—	—	ns	
\overline{OE} hold time	t_{OEH}	0	—	—	ns	
Data setup time	t_{DS}	100	—	—	ns	
Data hold time	t_{DH}	20	—	—	ns	
\overline{WE} pulse width (\overline{WE} controlled)	t_{WVP}	200	—	—	ns	
\overline{CE} pulse width (\overline{CE} controlled)	t_{CW}	200	—	—	ns	
Data latch time	t_{DL}	100	—	—	ns	
Byte load cycle	t_{BLC}	0.30	—	30	μ s	
Byte load window	t_{BL}	100	—	—	μ s	
Write cycle time	t_{WC}	—	—	10^2	ms	
Time to device busy	t_{DB}	120	—	—	ns	
Write start time	t_{DW}	150^3	—	—	ns	
Reset protect time	t_{RP}	100	—	—	μ s	
Reset high time	t_{RES}	1	—	—	μ s	

Notes: 1. Use this device in longer cycle than this value.

2. t_{WC} must be longer than this value unless polling technique or RDY/\overline{Busy} are used. This device automatically completes the internal write operation within this value.

3. Next read or write operation can be initiated after t_{DW} if polling technique or RDY/\overline{Busy} are used.

Byte Write Timing Waveform (1) (\overline{WE} Controlled)

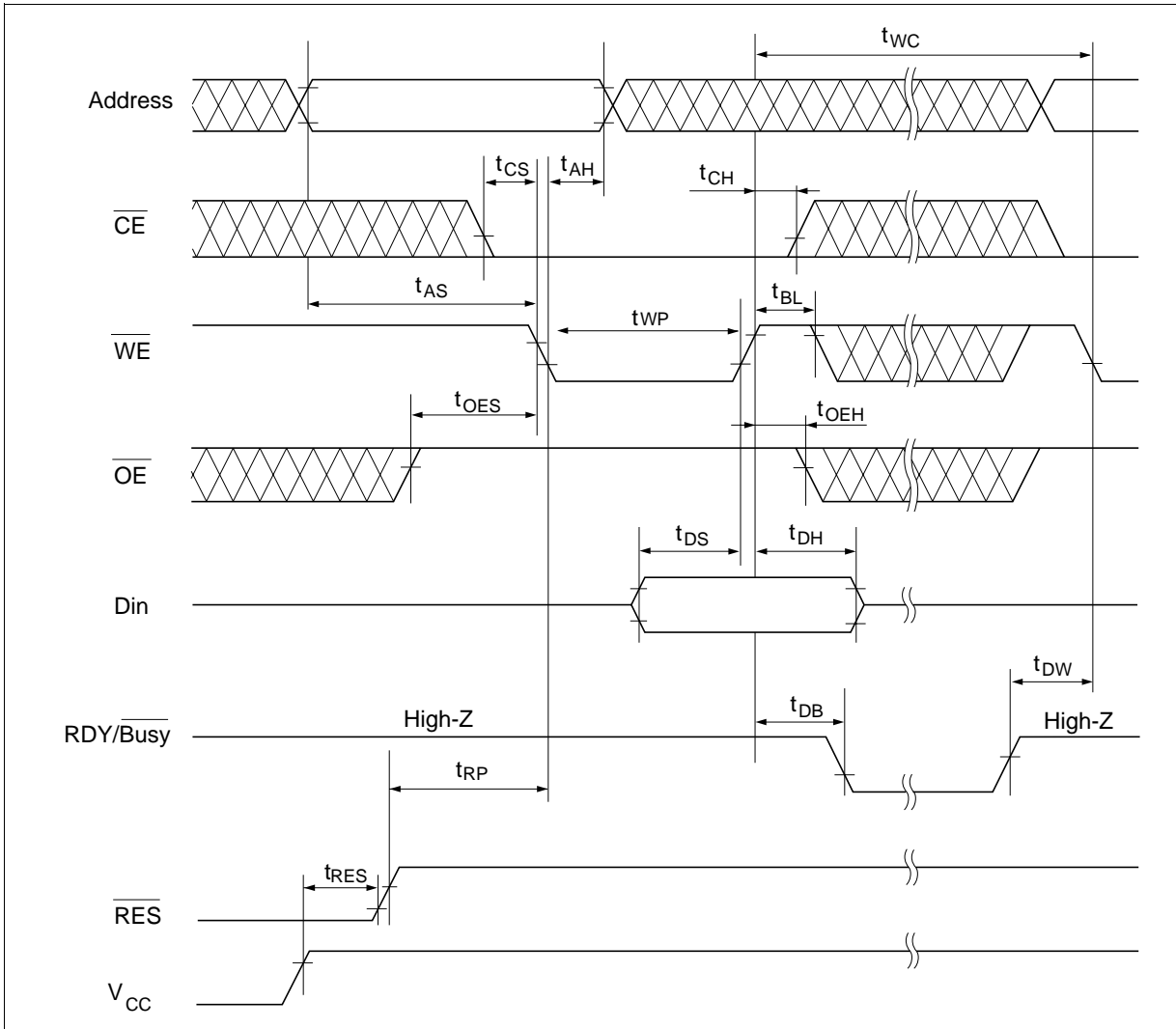

HN58C66 Series

Byte Write Timing Waveform (2) ($\overline{\text{CE}}$ Controlled)

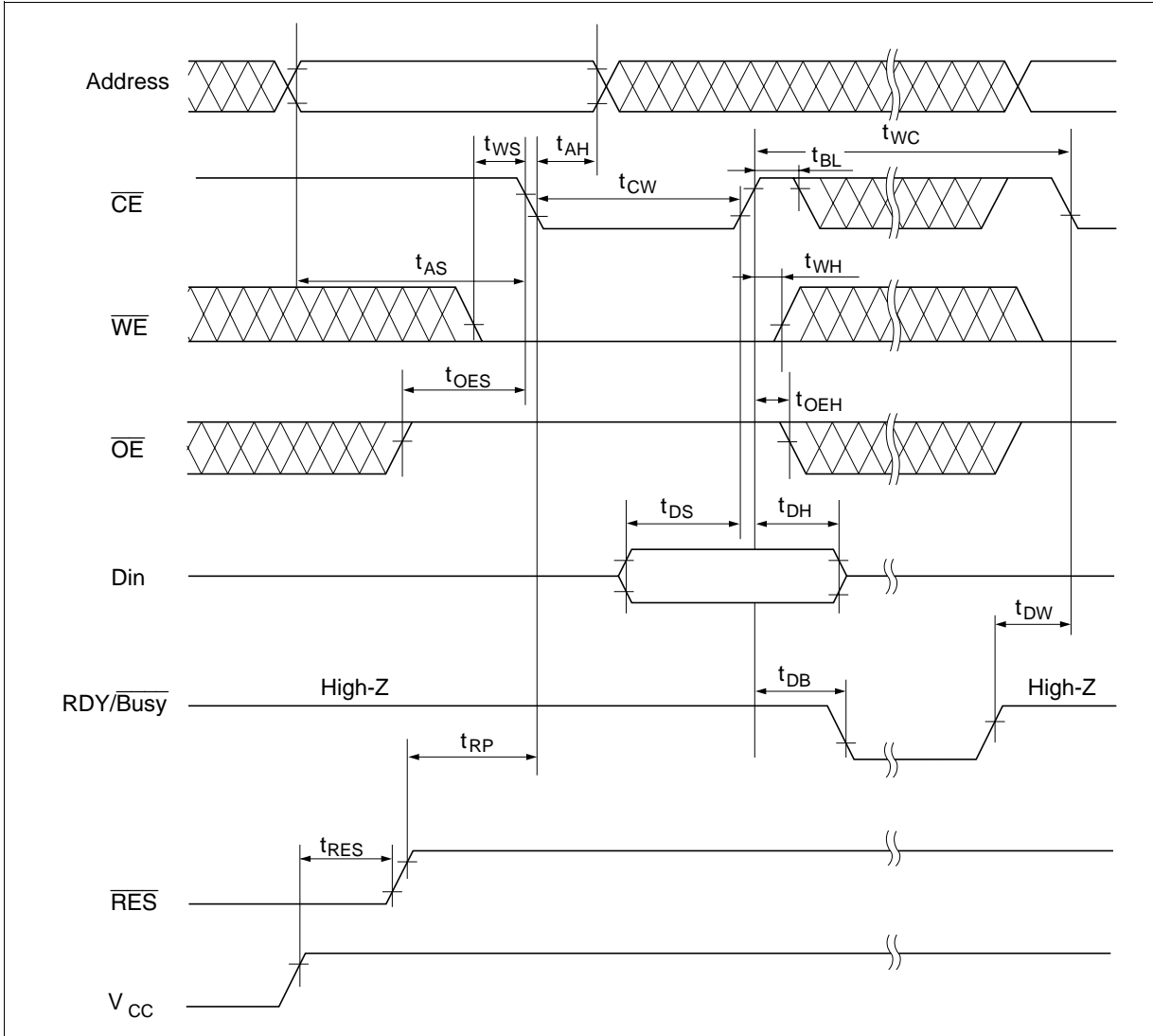

Page Write Timing Waveform (1) (\overline{WE} Controlled)

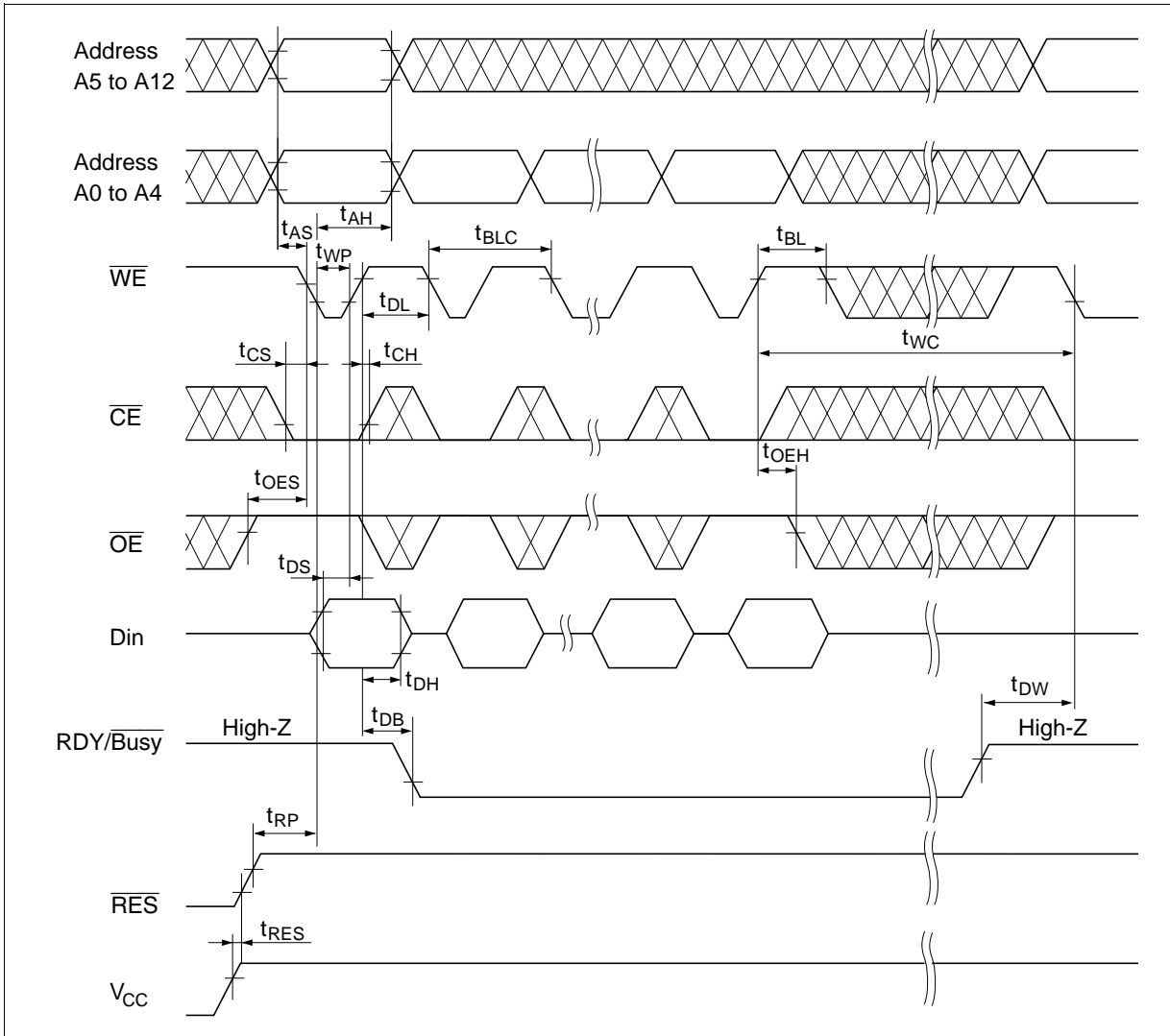

Page Write Timing Waveform (2) (\overline{CE} Controlled)

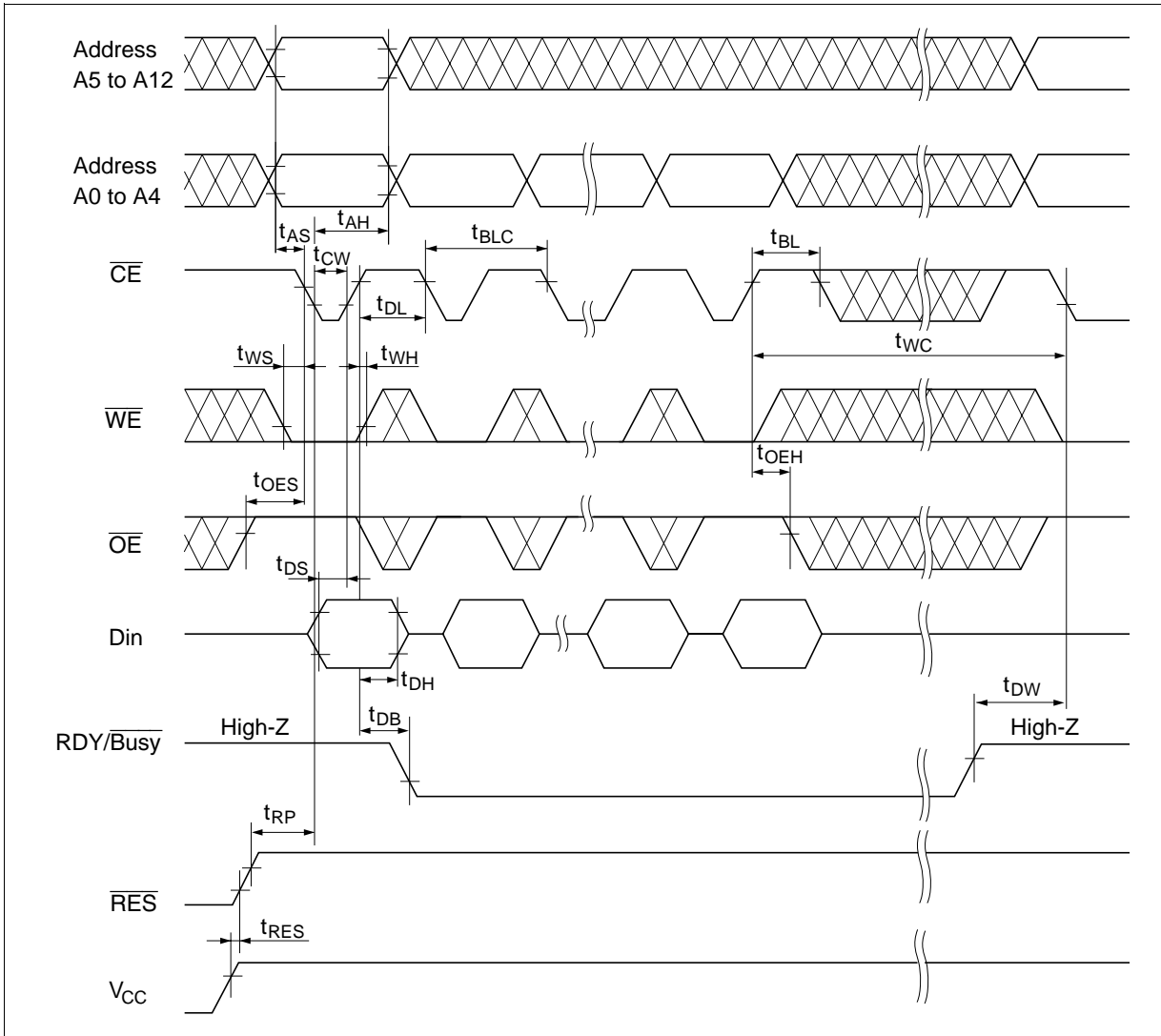

Data Polling Timing Waveform

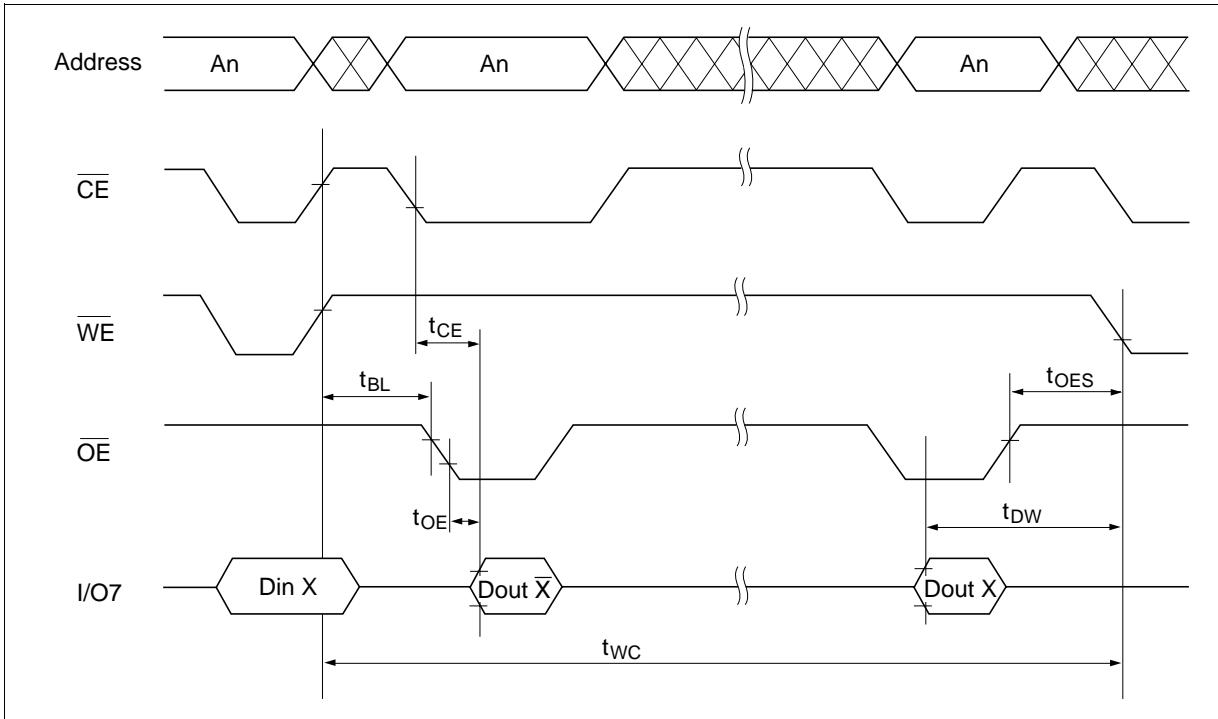

Functional Description

Automatic Page Write

Page-mode write feature allows 1 to 32 bytes of data to be written into the EEPROM in a single write cycle. Following the initial byte cycle, an additional 1 to 31 bytes can be written in the same manner. Each additional byte load cycle must be started within 30 μs from the preceding falling edge of \overline{WE} or \overline{CE} . When \overline{CE} or \overline{WE} is high for 100 μs after data input, the EEPROM enters write mode automatically and the input data are written into the EEPROM.

Data Polling

Data polling allows the status of the EEPROM to be determined. If EEPROM is set to read mode during a write cycle, an inversion of the last byte of data to be loaded outputs from I/O7 to indicate that the EEPROM is performing a write operation.

RDY/Busy Signal

RDY/Busy signal also allows the status of the EEPROM to be determined. The RDY/Busy signal has high impedance except in write cycle and is lowered to V_{OL} after the first write signal. At the end of a write cycle, the RDY/Busy signal changes state to high impedance.

RES Signal

When \overline{RES} is low, the EEPROM cannot be read or programmed. Therefore, data can be protected by keeping \overline{RES} low when V_{CC} is switched. \overline{RES} should be high during read and programming because it doesn't provide a latch function.

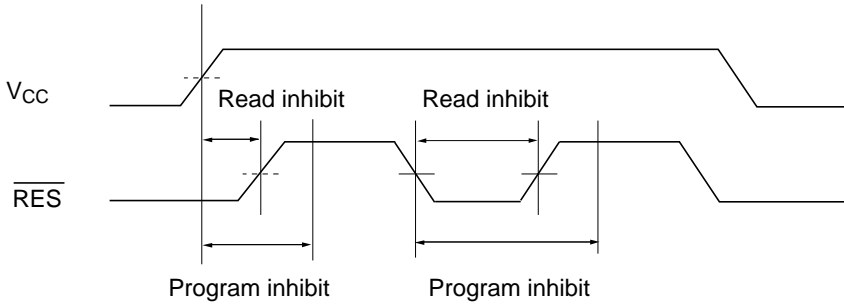

\overline{WE} , \overline{CE} Pin Operation

During a write cycle, addresses are latched by the falling edge of \overline{WE} or \overline{CE} , and data is latched by the rising edge of \overline{WE} or \overline{CE} .

Write/Erase Endurance and Data Retention

The endurance is 10^5 cycles in case of the page programming and 3×10^3 cycles in case of byte programming (1% cumulative failure rate). The data retention time is more than 10 years when a device is page-programmed less than 10^4 cycles.

Data Protection

1. Data Protection against Noise on Control Pins (\overline{CE} , \overline{OE} , \overline{WE}) during Operation

During readout or standby, noise on the control pins may act as a trigger and turn the EEPROM to program mode by mistake.

To prevent this phenomenon, this device has a noise cancelation function that cuts noise if its width is 20 ns or less in program mode.

Be careful not to allow noise of a width of more than 20 ns on the control pins.

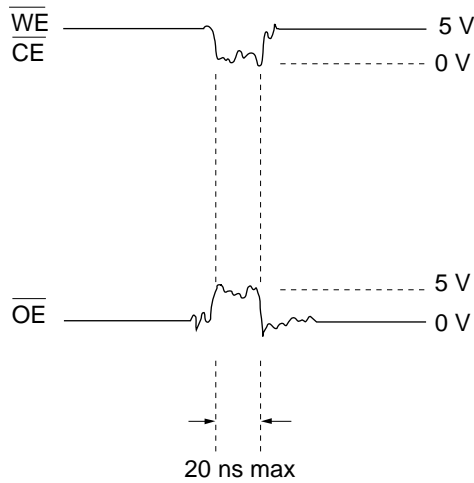

2. Data Protection at V_{CC} On/Off

When V_{CC} is turned on or off, the noise on the control pins generated by external circuits (CPU, etc.) may act as a trigger and turn the EEPROM to program mode by mistake. To prevent this unintentional programming, the EEPROM must be kept in an unprogrammable state by using a CPU reset signal to \overline{RES} pin. \overline{RES} pin should be kept at V_{SS} level when V_{CC} is turned on and off. The EEPROM breaks off programming operation when \overline{RES} becomes low, programming operation doesn't finish correctly in case that \overline{RES} falls low during programming operation. \overline{RES} should be kept high for 10 ms after the last data input.

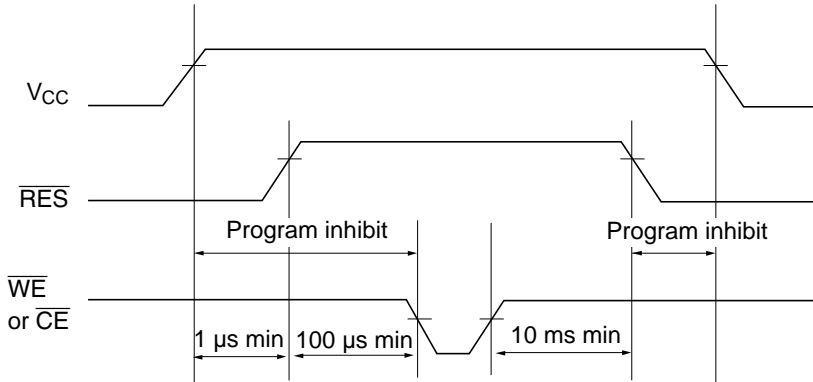

Package Dimensions

HN58C66P Series (DP-28)

Unit: mm

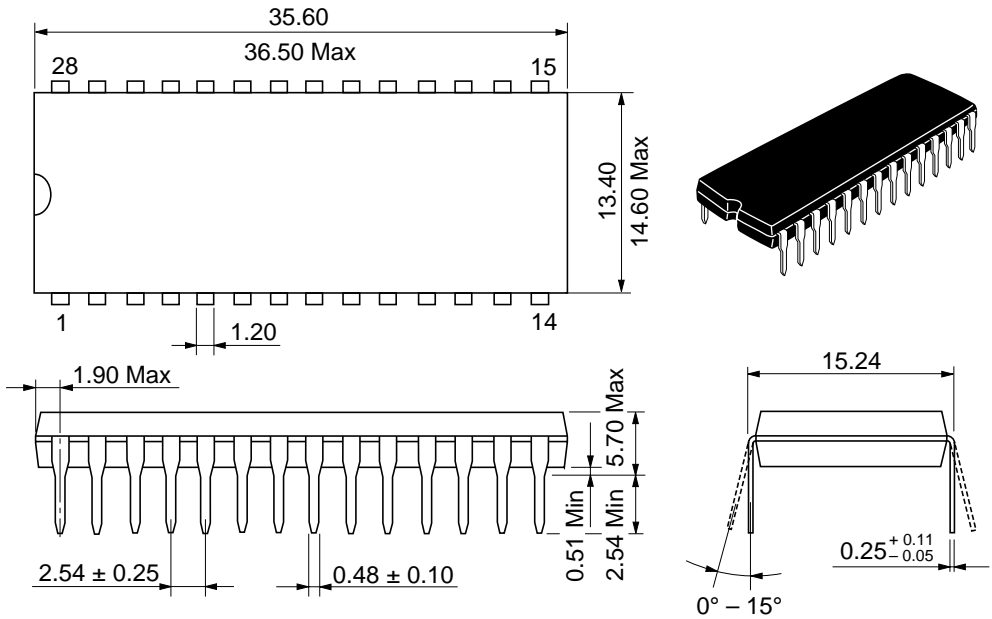

HN58C66FP Series (FP-28D)

Unit: mm

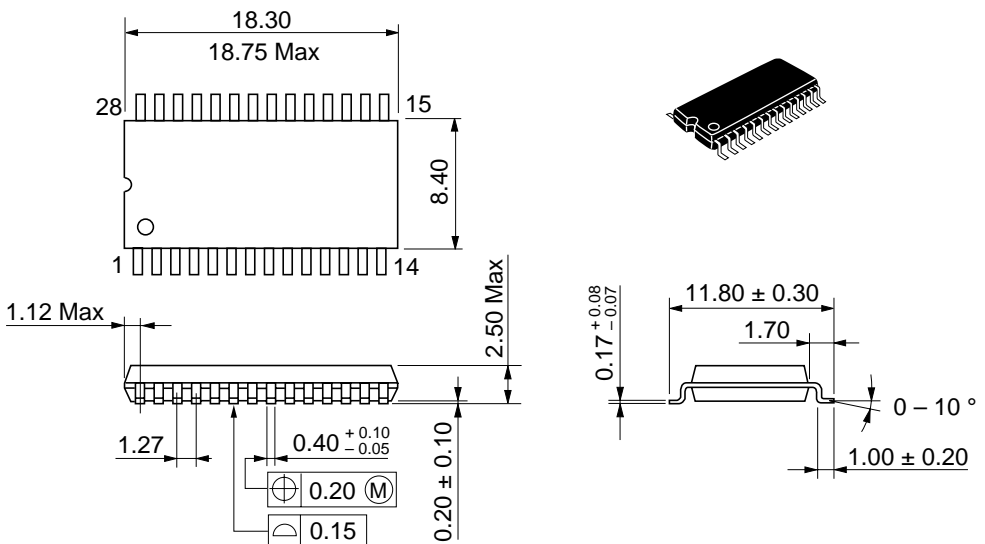

HN58C66 Series

HN58C66FP Series (FP-28DA)

Unit: mm

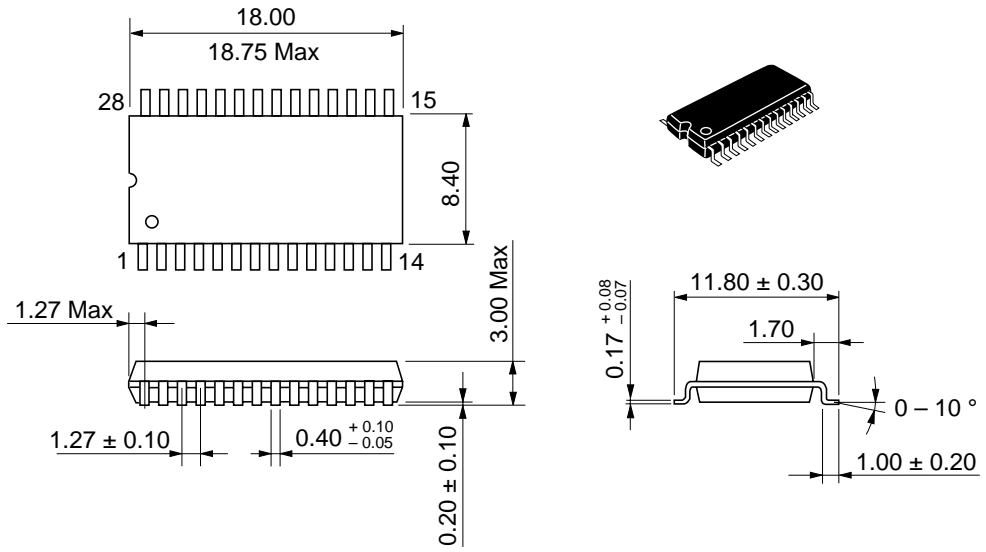

HN58C66T Series (TFP-32DA)

Unit: mm

