

Saves power during standby, enhances efficiency

MIP2C2 High-Performance IPD for Battery Chargers

Overview

MIP2C2 is a high-performance IPD designed for 7W battery chargers. It features built-in protection circuits necessary for compact power source charger circuitry. This allows a significant reduction in externally connected parts. MIP2C2 provides PWM control when a normal load is applied and intermittent control with low load. This results in greater efficiency for very low to maximum loads, while also conserving power during standby.

Features

- Built-in charge protection circuit
Built-in overcurrent, overheating, load shorting and overvoltage protection circuits
- Significantly reduced power consumption with no load*
20mW at 100VAC, 25mW at 240VAC
- High efficiency with rated load*
75% at 100VAC, 72% at 240VAC
- Reduced number of parts (12 less than conventional Panasonic models)
* With worldwide input and 5.8V/0.7A output

Applications

- Chargers (for cellular phones, etc.)

Block Diagram

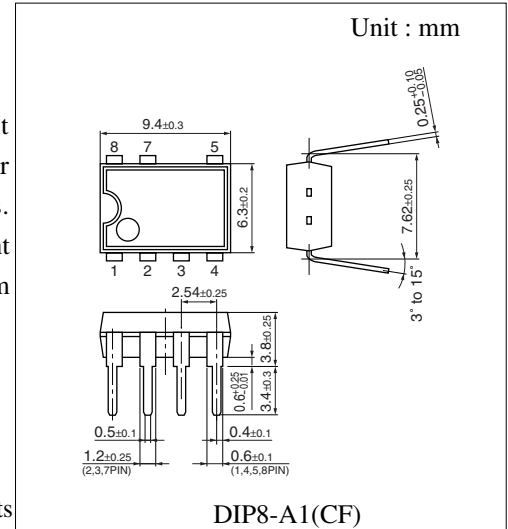
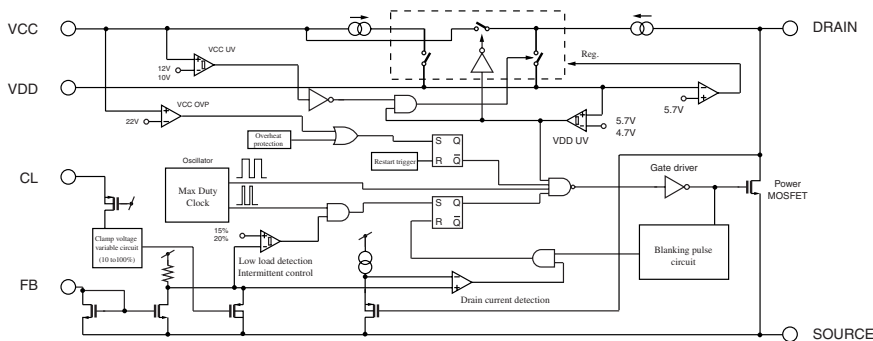

Pin Descriptions

Pin No.	Function
1	V _{DD}
2	FB
3	CL
4	V _{CC}
5	Drain
6	—
7	Source
8	Source

† The products and specifications are subject to change without any notice. Please ask for the latest product standards to guarantee the satisfaction of your product requirements.

■ Absolute Maximum Ratings

Parameters	Symbol	Rating	Unit
Drain voltage	V_D	700	V
Supply voltage	V_{CC}	30	V
Feedback voltage	V_{FB}	7	V
CL terminal voltage	V_{CL}	7	V
Drain current	I_D	500	V
Operating Junction Temperature	T_{ch}	150	°C
Storage temperature	T_{stg}	-55 to +150	°C

■ Electrical Characteristics ($T_a = 25^\circ\text{C} \pm 3^\circ\text{C}$)

Parameters	Symbol	Conditions	min	typ	max	Unit
(Control Function)						
Oscillator output frequency	f_{OSC}	FB:Open	90	100	110	kHz
Max. Duty cycle	MAXDC	FB:Open	-	50	-	%
VDD reference voltage	V_{DD}		-	5.7	-	V
VDD stop voltage	V_{UV}		-	5.1	-	V
Circuit current	I_{CC}		-	0.5	-	mA
VCC charge start voltage	$V_{CC(ON)}$		-	12	-	V
VCC charge stop voltage	$V_{CC(OFF)}$		-	10	-	V
VCC charge voltage hysteresis	ΔV_{CC}		-	2	-	V
VDD charge current	I_{ch1}	$V_{DD} = 0V$	-	3.0	-	mA
	I_{ch2}	$V_{DD} = 4V$	-	1.5	-	mA
Feedback current	I_{FB}		-	120	-	μA
Feedback current hystereses	I_{FBHYS}		-	3	-	μA
LC terminal current	I_{CLMAX}		20	-	-	μA
LC terminal current	I_{CLMIN}		-	-	5	μA
(Protection Function)						
Overcurrent detection	$I_{LIMITMIN}$	$I_{CL} < I_{CLMIN}$	-	0.05	-	A
	$I_{LIMITMAX}$	$I_{CL} > I_{CLMAX}$	-	0.35	-	
Overvoltage detection	$V_{CC(OV)}$		-	20	-	V
Overheating detection	T_{OTP}		130	140	150	°C
Latch reset voltage	V_{reset}		-	3	-	V
(Output Function)						
ON resistance	$R_{DS(ON)}$	$I_D = 0.1 \text{ A}$	-	22	27	Ω
Drain leak current	I_{DSS}	$V_{DS} = 630 \text{ V}$	-	-	250	μA
Drain breakdown voltage	V_{DSS}	$I_D = 0.25 \text{ mA}$	700	-	-	V
Rise time	t_r		-	100	-	ns
Fall time	t_f		-	50	-	ns
(Supply Voltage)						
Minimum drain voltage	$V_{D(MIN)}$		50	-	-	V

■ Electrical Characteristics (With 100VAC input and 5.8V/0.7A output)

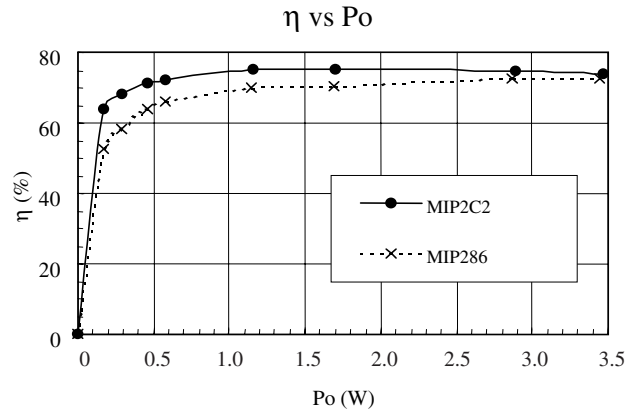
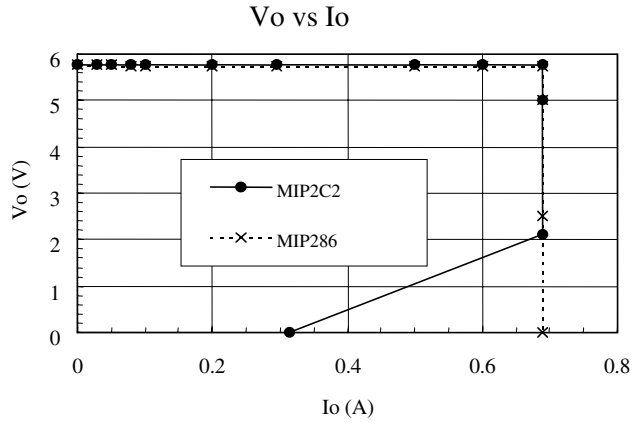

■ Application Circuit Example

