



GENERAL DESCRIPTION

The SM5262B is a RF remote control encoder paired with SM5272B. It utilizes CMOS technology. The chip has 12 bits of 3-state address pins that provides 3¹² codes. SM5262B/ SM5272B pair is suitable for use on remote controller.

FEATURES

- * CMOS technology
- * Low power consumption
- * 12 tri-state pins
- * Wide range operating voltage, V_{cc} = 2.5-12V
- * Up to six data bits
- * High noise immunity

APPLICATIONS

- * Garage Door
- * Ceiling Fan
- * Toys

PIN ASSIGNMENTS

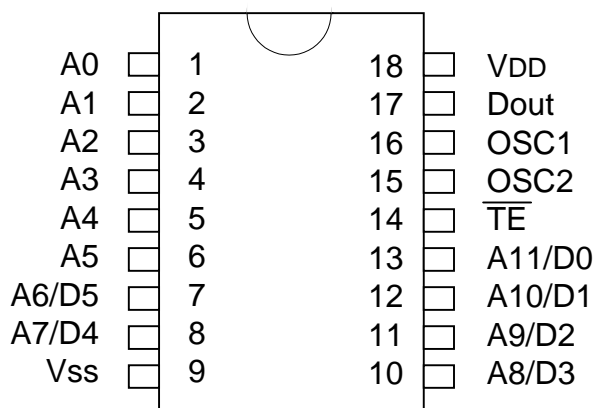

SM5262B

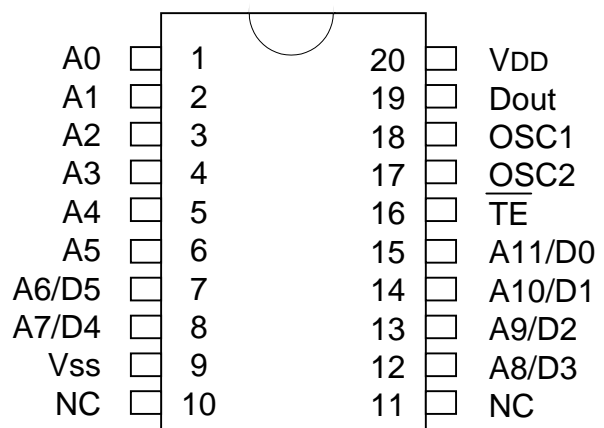

SM5262BS

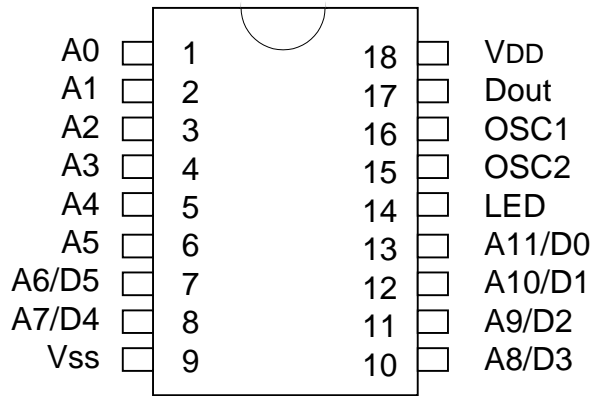

SM5262B-DX

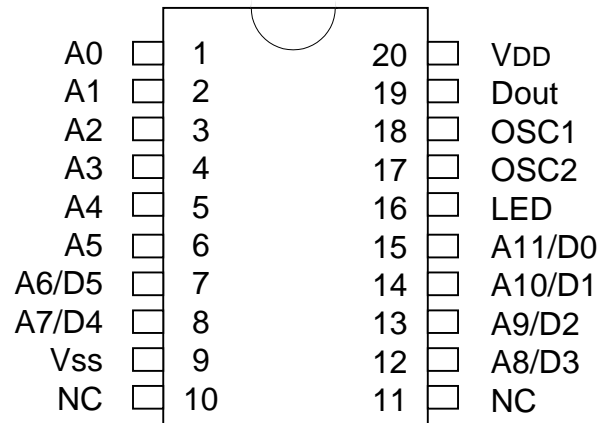

SM5262BS-DX

BLOCK DIAGRAM

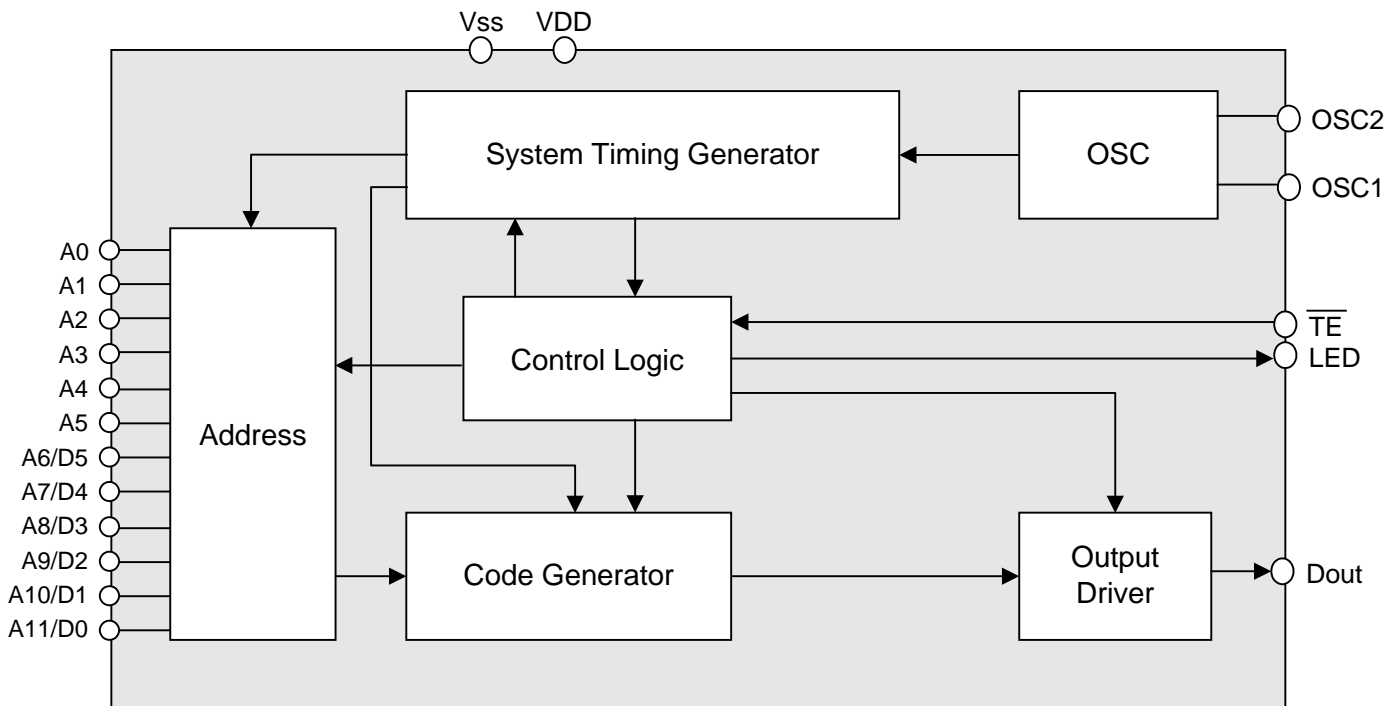



PIN FUNCTION

No.	Pin Name	I/O	Function Operation
1	A0	I	Address input, each pin can be set to "0", "1", or floating.
2	A1	I	
3	A2	I	
4	A3	I	
5	A4	I	
6	A5	I	
7	A6/D5	I/O	Address input or data output.
8	A7/D4	I/O	
9	VSS	POWER	Negative power supply.
10	A8/D3	I/O	Address input or data output.
11	A9/D2	I/O	
12	A10/D1	I/O	
13	A11/D0	I/O	
14	$\overline{\text{TE}}$	I	Enables transmission.
	LED	O	LED Output.
15	OSC1	I	Resistor connected between these two pins determine the system clock.
16	OSC2	O	
17	Dout	O	Serial output of encoded signals.
18	VDD	POWER	Positive power supply.



FUNCTION DESCRIPTION

1. Data Format

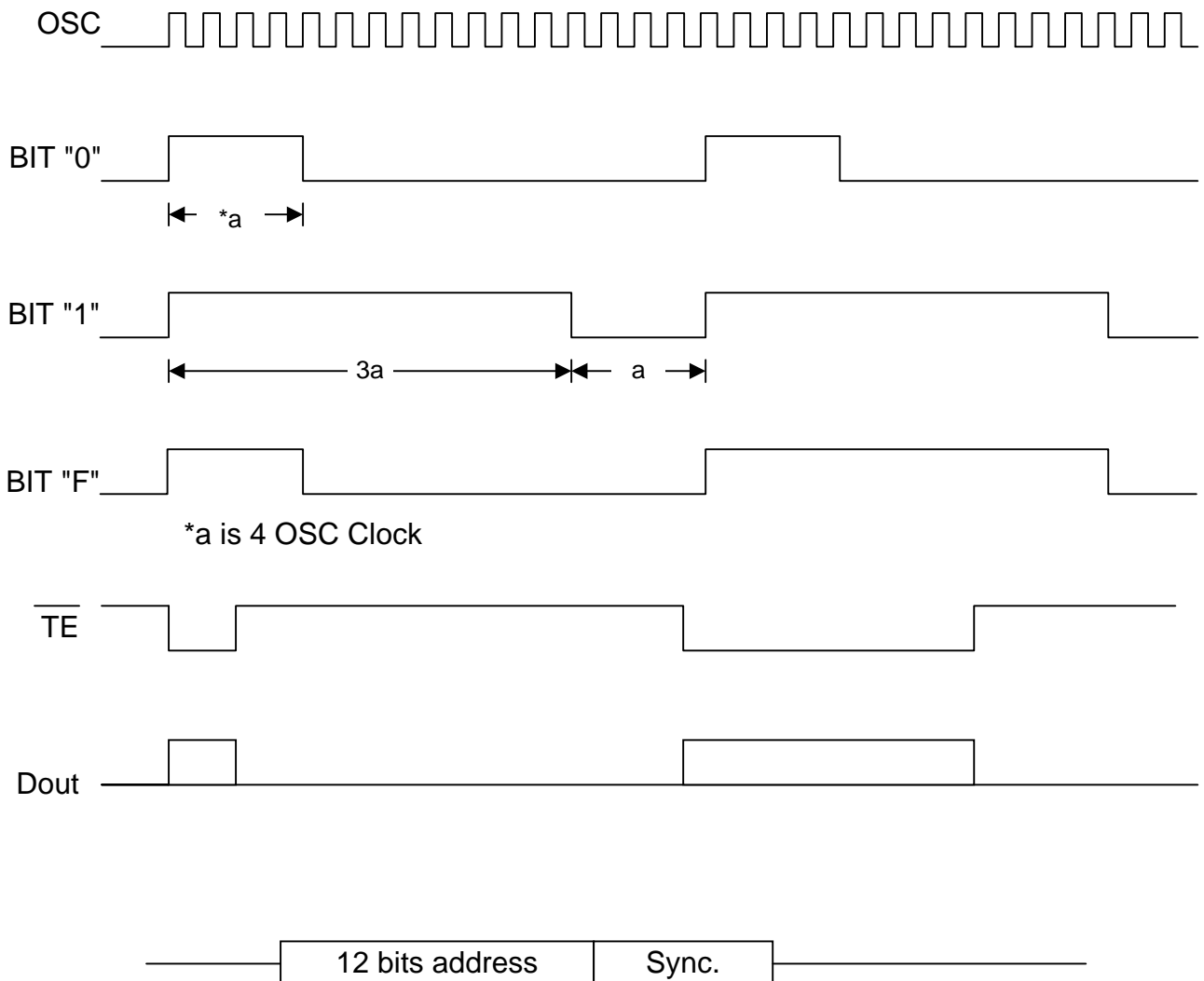

Synchronisation Bit waveform is :

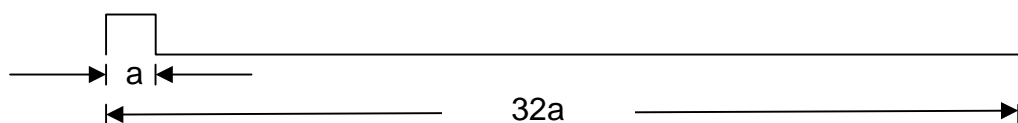



2. Frame Format

When SM5262B is used for no data, transmitting format is :

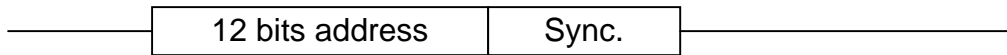

Synchronisation Bit waveform is :

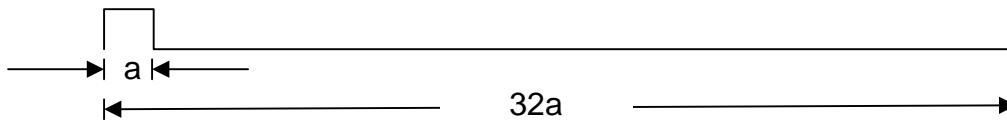

When data type of SM5262B is used, address bits will decrease accordingly. For example, in 3 data type where address is 9 bits, transmitting format is :

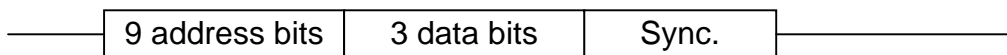

SM5262B/ SM5272B has 12 bits including a maximum of 6 data bits.

first transmission bit
in real signal A0 will be receive first.

A0	A1	A2	A3	A4	A5	A6	A7	A8	A9	A10	A11	Sync.	According to
A0	A1	A2	A3	A4	A5	A6	A7	A8	A9	A10	A11	Sync.	SM5272B
A0	A1	A2	A3	A4	A5	A6	A7	A8	A9	D1	D0	Sync.	SM5272B-M2/L2
A0	A1	A2	A3	A4	A5	A6	A7	A8	D2	D1	D0	Sync.	SM5272B-M3/L3
A0	A1	A2	A3	A4	A5	A6	A7	D3	D2	D1	D0	Sync.	SM5272B-M4/L4
A0	A1	A2	A3	A4	A5	A6	D4	D3	D2	D1	D0	Sync.	SM5272B-M5/L5
A0	A1	A2	A3	A4	A5	D5	D4	D3	D2	D1	D0	Sync.	SM5272B-M6/L6



Single Resistor Oscillator

SM5262B's oscillator be constructed by connecting a resistor between OSC1 and OSC2 pin.
SM5272B's OSC frequency must be 1.4 to 6.8 times more than SM5262B.

Encoder OSC Frequency

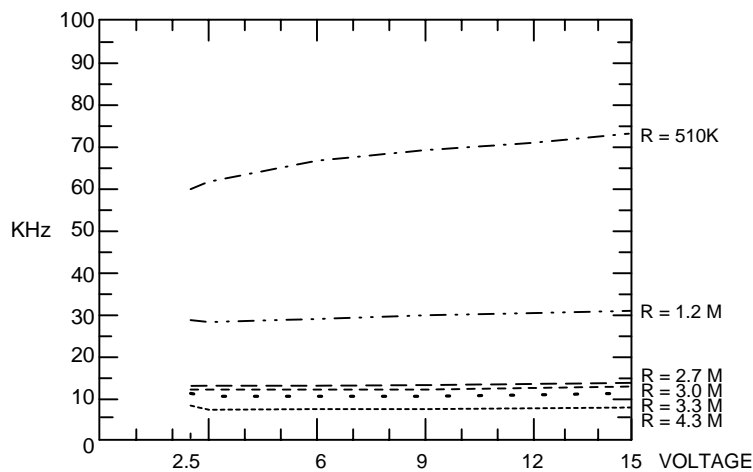

Decoder OSC Frequency

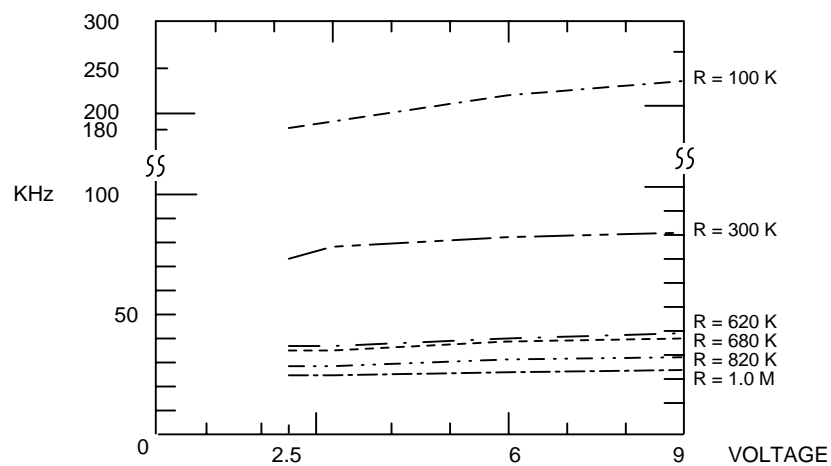

Suggested oscillator resistor of SM5262B/ SM5272B:

SM5262B	SM5272B
4.7M OHM	750K OHM
3.0M OHM	390K OHM
2.2M OHM	270K OHM
1.2M OHM	160K OHM



ABSOLUTE MAXIMUM RATINGS

Parameter	Symbol	Conditions	Ratings	Unit
Supply Voltage	VDD - Vss		-0.3 ~ 16	V
Input Voltage	VI - Vss		Vss - 0.3 ~ VDD +0.3	V
Output Voltage	VO - Vss		Vss - 0.3 ~ VDD +0.3	V
Maximum power dissipation	Pa	VDD - Vss = 12 V	500	mW
Operating Temperature	Topr		-20 ~ 70	
Storage Temperature	Tstg		-40 ~ 125	

DC ELECTRICAL CHARACTERISTICS

Parameter	Symbol	Conditions	Limit			Unit
			Min.	Typ.	Max.	
Supply Voltage	VCC		2.5		12	V
Standby Current	ISTB	VDD=12V OSC stop AO - A11 open		0.02	0.3	μA
Output Drive Current (Dout)	IOH	VDD = 5V VOH = 4V VDD = 8V VOH = 6.4V VDD = 12V VOH = 9.6V	- 2 - 8 -16			mA
Output Sinking Current (Dout)	IOL	VDD = 5V VOL = 1V VDD = 8V VOL = 1.6V VDD = 12V VOL = 2.4V	7 16 29			mA



APPLICATION CIRCUIT

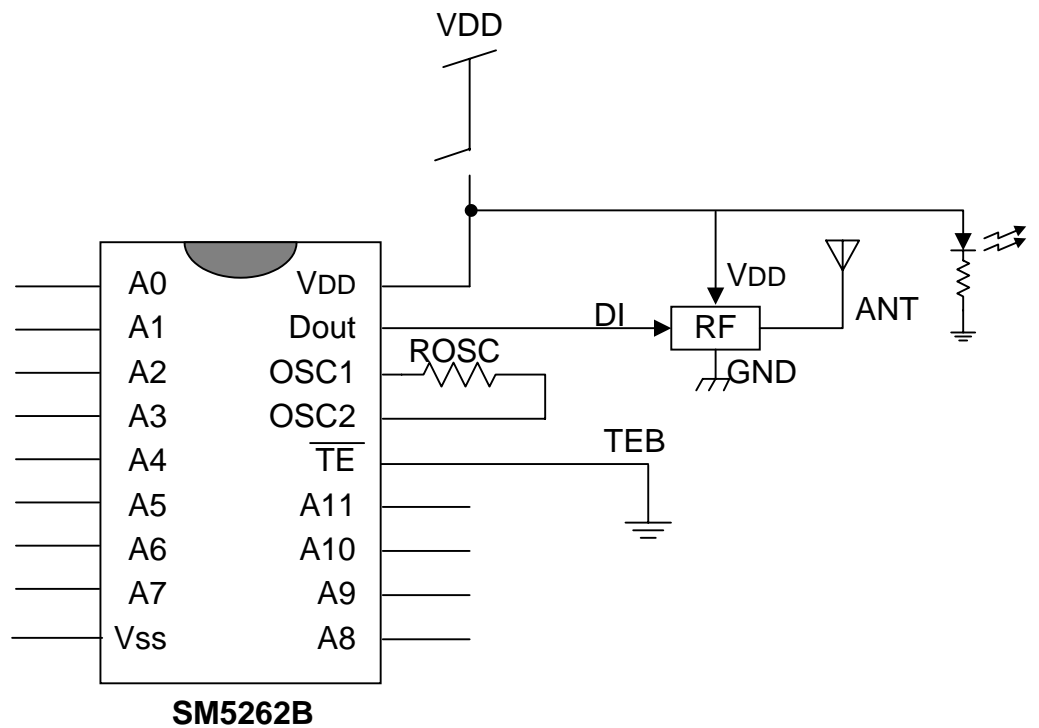
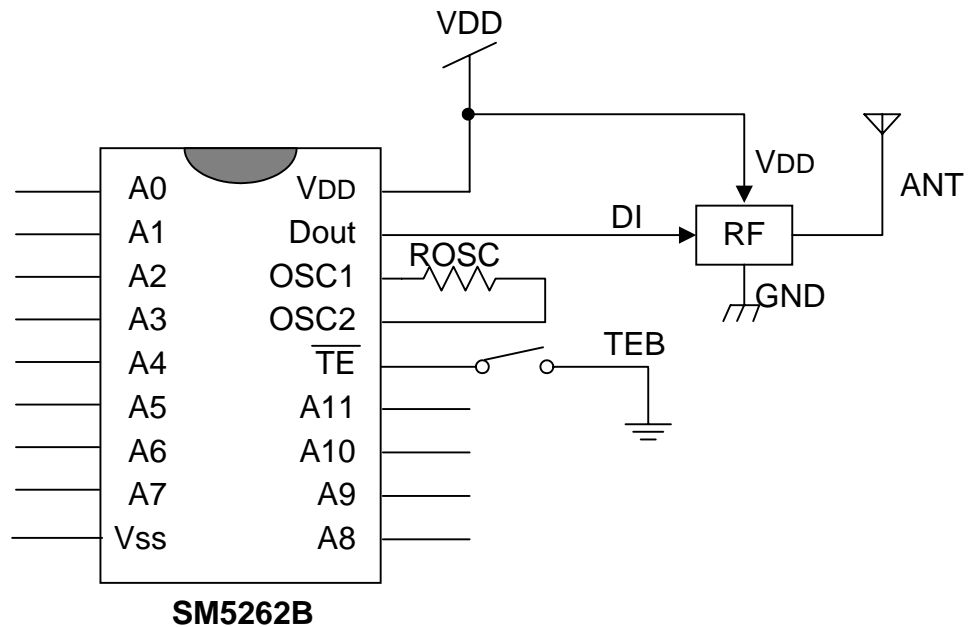

RF : Module reference to Page11



APPLICATION CIRCUIT

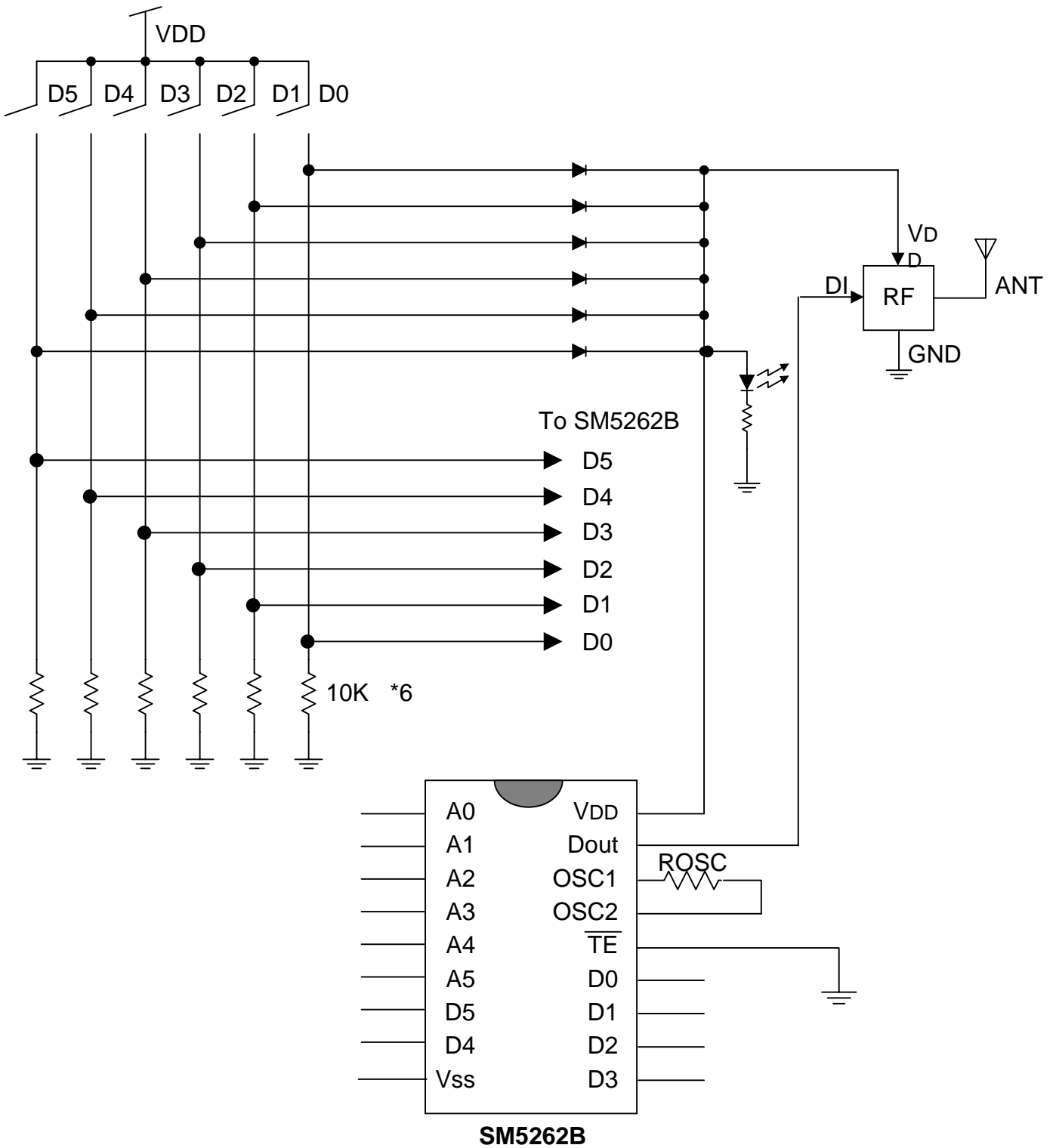



APPLICATION CIRCUIT

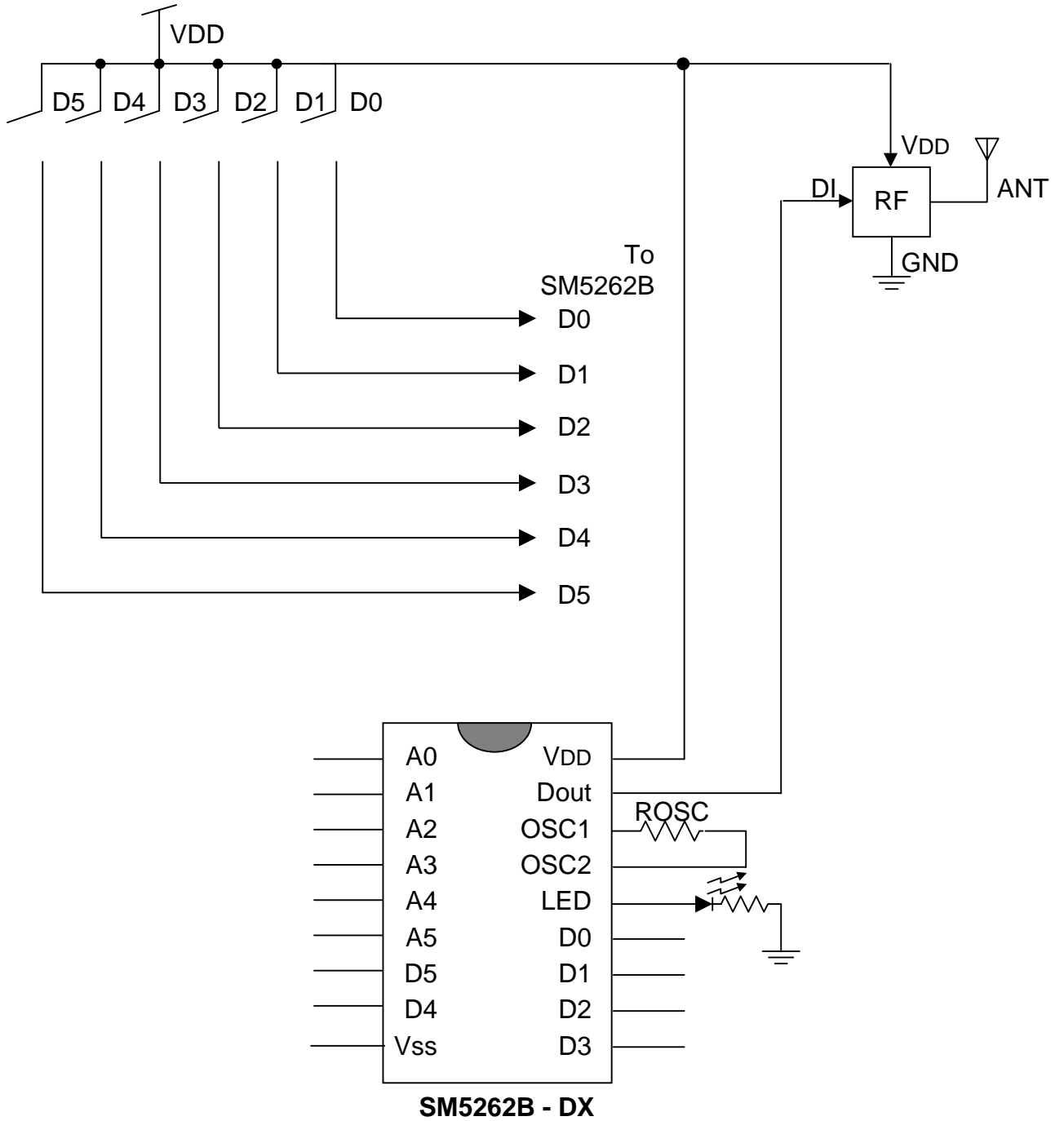



APPLICATION CIRCUIT

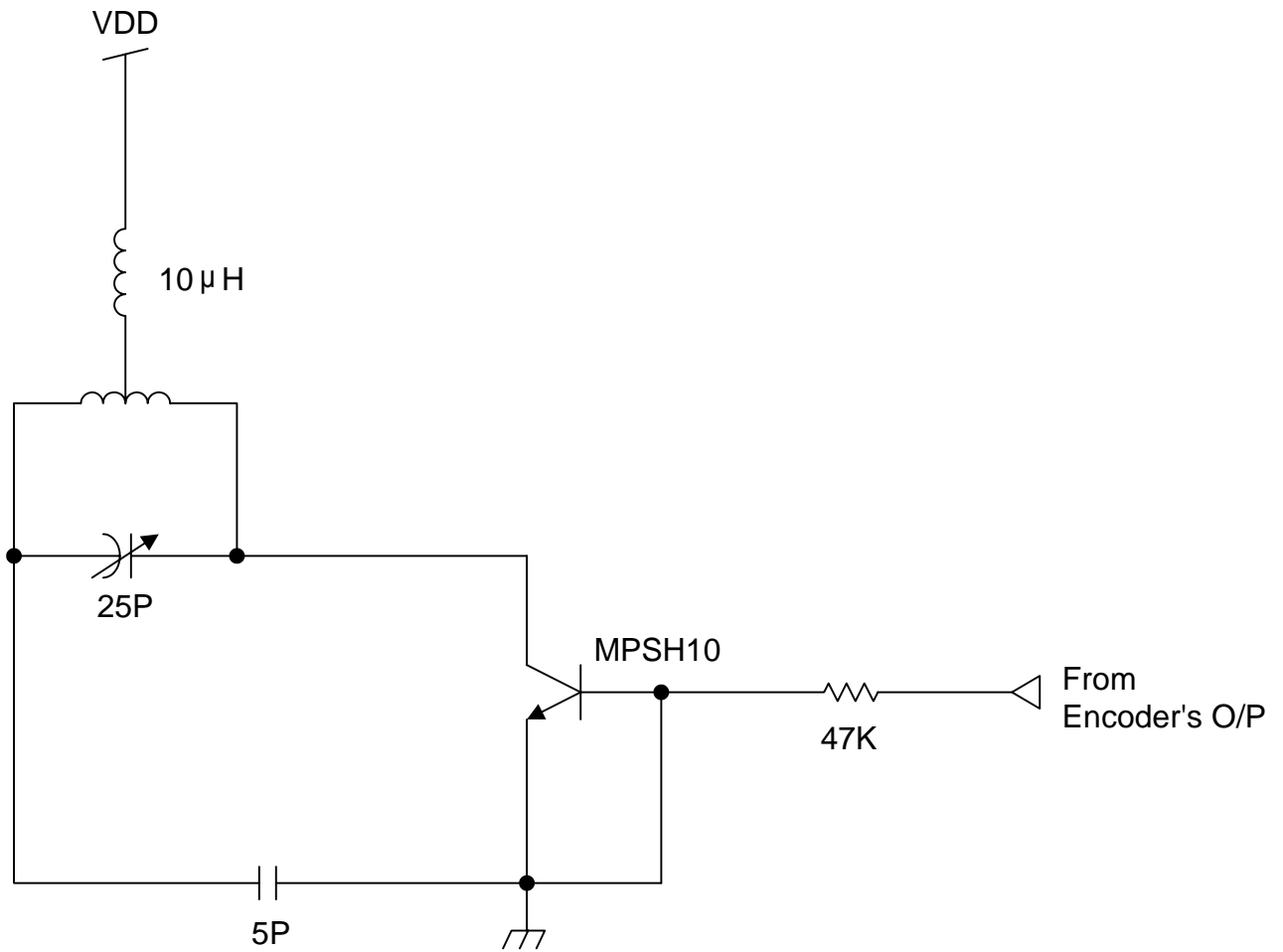



ORDERING INFORMATION

Part No.	Package
SM5262B	18 Pin DIP

Part No.	Package
SM5262BS	20 Pin SOP

