



SEMICONDUCTOR

LT104V3-100 Specifications

April 1995, Rev. 0

Preliminary

CONTENTS

	<u>PAGE</u>
Record of Revision	3
General Description	4
1. Absolute Maximum Rating	5
1-1 Environmental Absolute Ratings	
1-2 Electrical Absolute Ratings	
2. Optical Characteristics	6
3. Electrical Characteristics	8
4. Block Diagram	9
5. Input Terminal Pin Assignment	10
6. Interface Timing	11
6-1 Timing Parameters	
6-2 Timing Diagrams of Interface Sequence	
6-3 Power ON/OFF Sequence	
7. Dimensional Outline	17
8. Reliability Test	18
9. Packing, Transportation and Delivery	19
10. Markings	20
11. Product Inspection	21
12. Handling Precaution	22

RECORD OF REVISION

Date	Sheet No.	Summary	Note

GENERAL DESCRIPTION

DESCRIPTION

LT104V3- 10S is the color active matrix TFT (Thin Film Transistor) liquid crystal display (LCD) using amorphous silicon TFT's as switching devices. It is composed of a TFT LCD panel, driver circuit and backlight system. The 10.4 inches diagonal display area contains 640 x 480 pixels and can display 262,144 colors. Optimum viewing direction is 6 o'clock. 400 line and 350 line mode in addition to the 480 line mode can be also applied for this module

FEATURES

- Thin and light weight
- High contrast ratio, wide viewing angle, wide color gamut
- High-speed response
- VGA (640x480 pixels)
- Low power consumption
- Single CCFL
- Sync only function.

APPLICATIONS

- A4 size notebook computer
- Display terminals for NC machine
- Control board for NC machine
- Monitors for process controller

General Specifications

ITEM	SPECIFICATION	UNIT
Display area	211.2(H) x 158.4(V) (diagonal size 10.4 ")	mm
Drive	a-Si TFT active matrix	
Display colors	262,144 colors	
Number of pixels	640 x 480	pixel
Pixel arrangement	RGB vertical stripe	
Pixel pitch	0.33(H) x 0.33(W)	mm
Module Size	264(W) x 180(H) x 9.3(D)	mm
Weight	500 (Typ.)	g

1. ABSOLUTE MAXIMUM RATINGS

1.1 ENVIRONMENTAL ABSOLUTE RATINGS

ITEM	OPERATING		STORAGE		UNIT	NOTE
	MIN.	MAX.	MIN.	MAX.		
Ambient Temp.	0	50	-25	60	°C	
Humidity	-	-	-	90	%RH	
Vibration	-	-	-	14.7(1.5G)	m/s ²	
Shock	-	-	-	980(100G)		
Corrosive Gas	NOT ACCEPTABLE		NOT ACCEPTABLE		-	

1.2 ELECTRICAL ABSOLUTE RATINGS

(1) TFT LCD MODULE

ITEM	SYMBOL	MIN.	MAX.	UNIT	NOTE
Power Supply Voltage	V _{DD}	-0.5	6.5	V	T _a = 25 °C
Input Voltage	V _{IN}	-0.3	V _{DD} + 0.3	V	
Electro-static Durability	V _{TER}	-	± 200	V	(1),(2)
	V _{CHA}	-	± 5	kV	(1),(3)

Note (1) 200 pF, 0 Ω, 25 °C, 50%RH

(2) Interface connector pins are subjected

(3) The surface of chassis and LCD panel are subjected

(2) BACK-LIGHT UNIT

ITEM	SYMBOL	MIN.	TYP.	MAX.	UNIT	NOTE
Lamp Current	I _L	2.0	3.6	6.0	mA	(1)
Lamp Voltage	V _L	-	510	-	V _{rms}	

Note (1) CCFT lamp be stable in this current range

2. OPTICAL CHARACTERISTICS

The following items are measured when the conditions of this unit and measuring systems are stable. The ambient light excluding back-light is nothing.

: Measuring equipment : TOPCON BM-7

ITEM		SYMBOL	CONDITION	MIN	TYP	MAX	UNIT	NOTE
Contrast Ratio		CR	Optimal Viewing Angle	100:1	-	-		(1), (2), (7)
Response Time	Rise	T_R	$T_a = 25^\circ\text{C}$	-	20	-	msec	(3),(7)
	Fall	T_F		-	40	-		
Color Chromaticity (CIE)	White	W_X	$\phi = 0$ $\theta = 0$ $T_a = 25^\circ\text{C}$	0.2943	0.3143	0.3343		(1)
		W_Y		0.3069	0.3267	0.3467		
	Red	R_X		0.5863	0.6063	0.6263		
		R_Y		0.3139	0.3339	0.3539		
	Green	G_X		0.2755	0.2955	0.3155		
		G_Y		0.5478	0.5678	0.5878		
	Blue	B_X		0.1256	0.1456	0.1656		
		B_Y		0.1095	0.1295	0.1495		
Viewing Angle	Hor.	θ_L	CR > 10	45	48	50	degrees	(1)
		θ_R		45	48	50		
	Ver.	ϕ_H		10	15	20		
		ϕ_L		30	35	40		
Luminance				60	70		cd/m ²	(4),(7)
White Uniformity				-	-	1.25		(5),(7)
Cross Modulation				-	-	1:1.05	%	(6)
Maximum Dark Luminosity				-	-	1	cd/m ²	(7)

Note (1) Definition of Viewing Angle

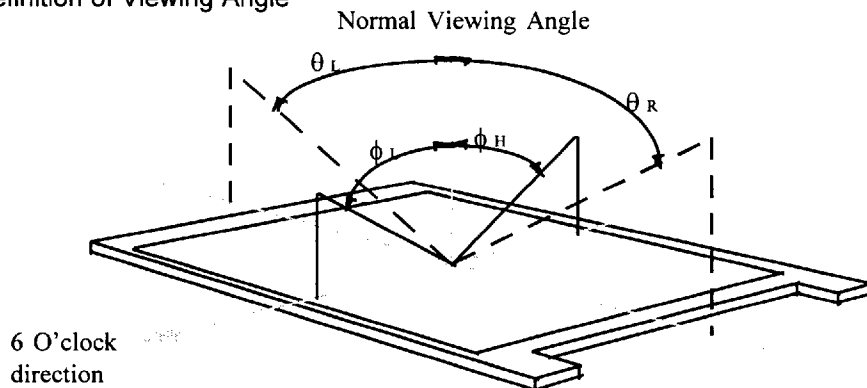

Note (2) Definition of Contrast Ratio(CR)

$$CR = \frac{\text{Luminance(Brightness) of white}}{\text{Luminance(Brightness) of Black}}$$

Note (3) Definition of Response time

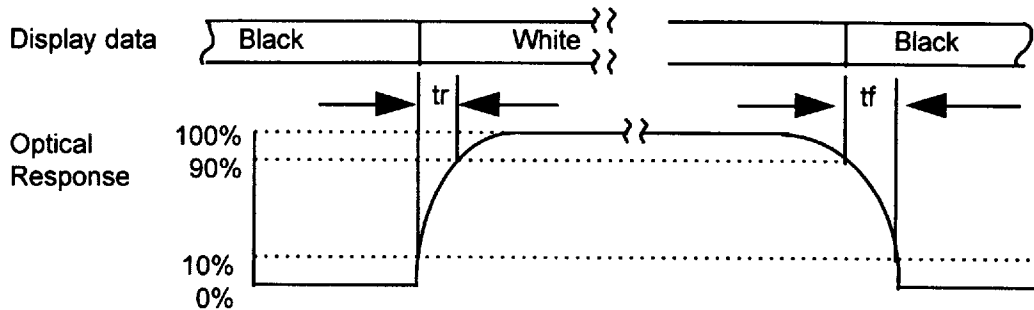

Note (4) Definition of Luminance : This luminance provided at 3.5mA of CCFT lamp current

Note (5) Definition of Uniformity : check the white luminance variation at 5 test points

$$\text{Uniformity} = \frac{\text{MAX luminance}}{\text{MIN luminance}}$$

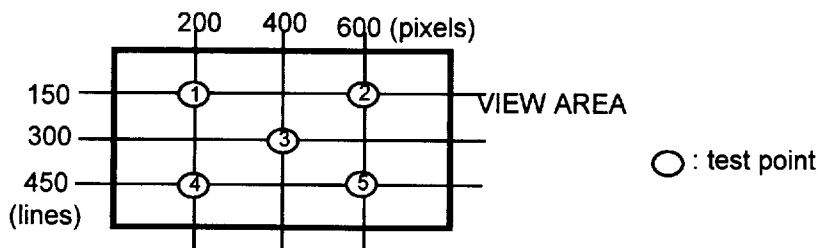

Note (6) Definition of Cross Modulation

$$\text{Cross Modulation Ratio} = \frac{|Y_B - Y_A|}{Y_B} \times 100 (\%)$$

Where:

Y_A = Luminance of measured location without darkest gray pattern (cd/m^2)

Y_B = Luminance of measured location with darkest gray pattern (cd/m^2)

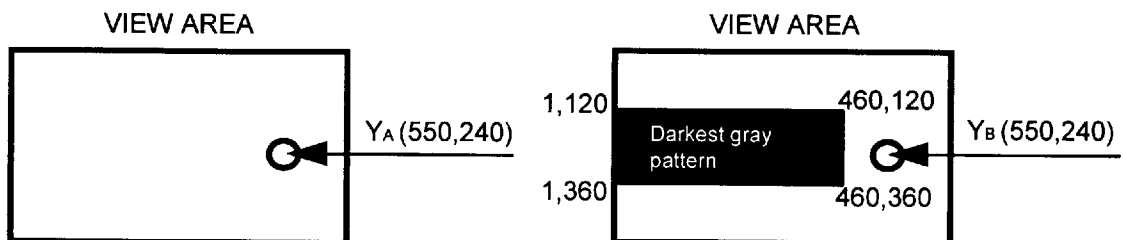

Note (7) Test condition

- At least 20 minutes after CCFT turn on and being run at 40KHz and a 3.6mA current
- V_{cc} shall be 12.0 ± 0.1 volts at 25°C

3. ELECTRICAL CHARACTERISTICS

(1) TFT LCD MODULE

Ta=25°C

ITEM	SYMBOL	MIN	TYP	MAX	UNIT	NOTE
Power Supply Voltage	V _{DD}	4.75	5.0	5.25	V	
Input Voltage for Logic Signals	High	V _{IH}	0.7 V _{DD}	-	V _{DD}	(1)
	Low	V _{IL}	V _{SS}	-	0.3 V _{DD}	(1)
Power Supply Current	I _{DD}	170	230	300	mA	(2),(3),(4)
Vsync Frequency	f _v	-	60	-	Hz	
Hsync Frequency	f _H	-	31.78	-	kHz	
Main Frequency	f _{DCLK}	-	25.175	30	MHz	

Note (1) Display data pins and timing signal pins are subjected.
 (2) f_v=60Hz, f_{CLK} =25MHZ, V_{DD} = 5.0V, DC Current.

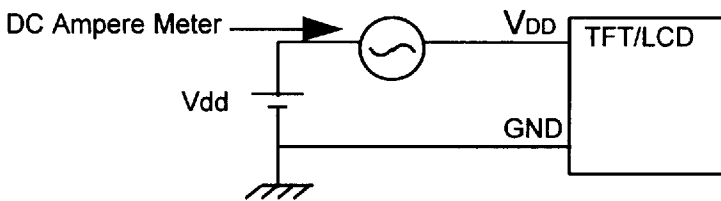

(3) Current capacity for V_{DD} power source should be larger than 3A.

(4) Power dissipation check pattern

1. Minimum Power Dissipation

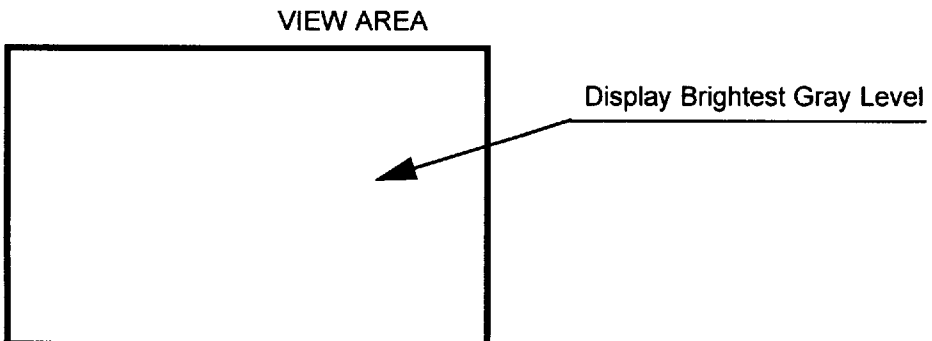

2. Typical Power Dissipation

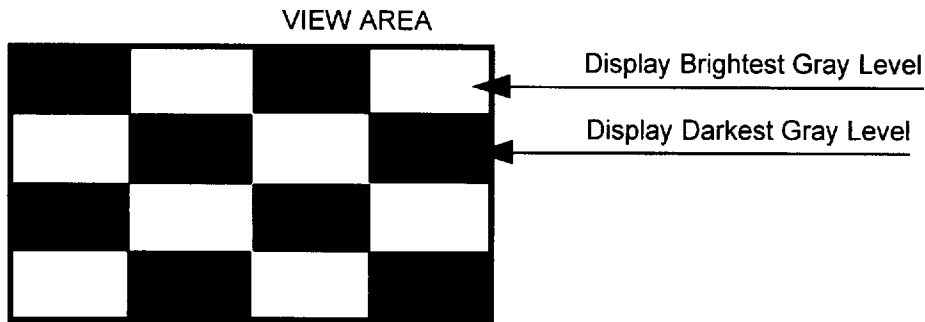

3. Maximum Power Dissipation

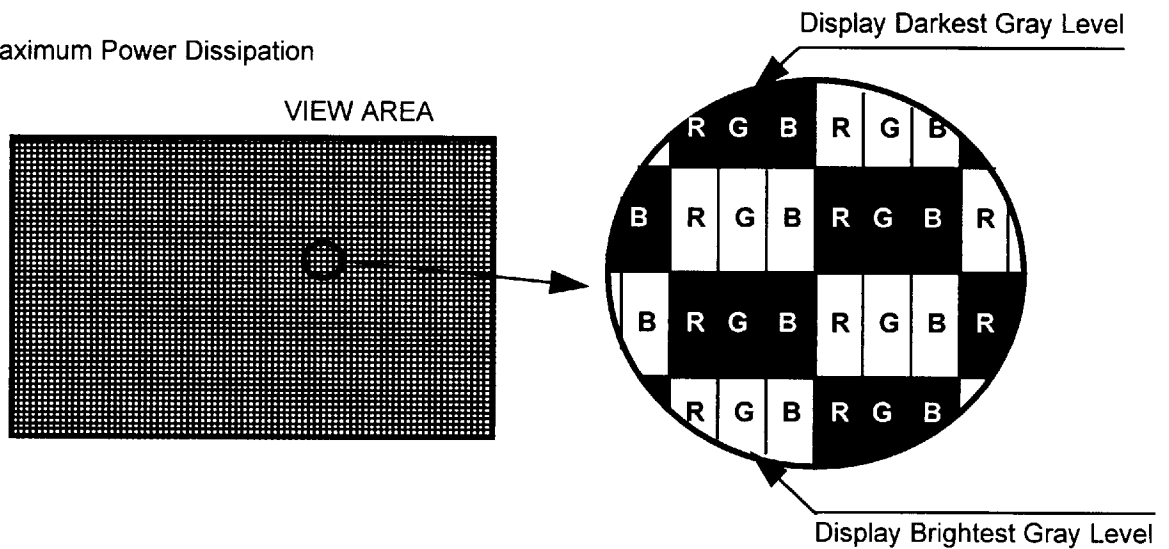

(2) BACK-LIGHT UNIT

Ta=25°C

ITEM	SYMBOL	MIN	TYP	MAX	UNIT	NOTE
Lamp Current	I_L	2.0	3.6	6.0	mArms	(1)
Lamp Voltage	V_L	-	510	-	Vrms	
Frequency	f_L	-	40	-	kHz	
Start-up Voltage	V_S	-	-	950	Vrms	(2)
Lamp Power	P_L	-	2.0	-	W	
Lamp Life Time	H_r	10,000	-	-	Hour	(3)
Lamp Startup Time		-	30	1,000	msec	

Note (1) Higher I_L cause the short life time of CCFL

(2) 1400 Vrms at Ta = 0 °C

(3) Brightness become 50% of the original brightness at the standard condition.

4. BLOCK DIAGRAM

(1) TFT LCD MODULE

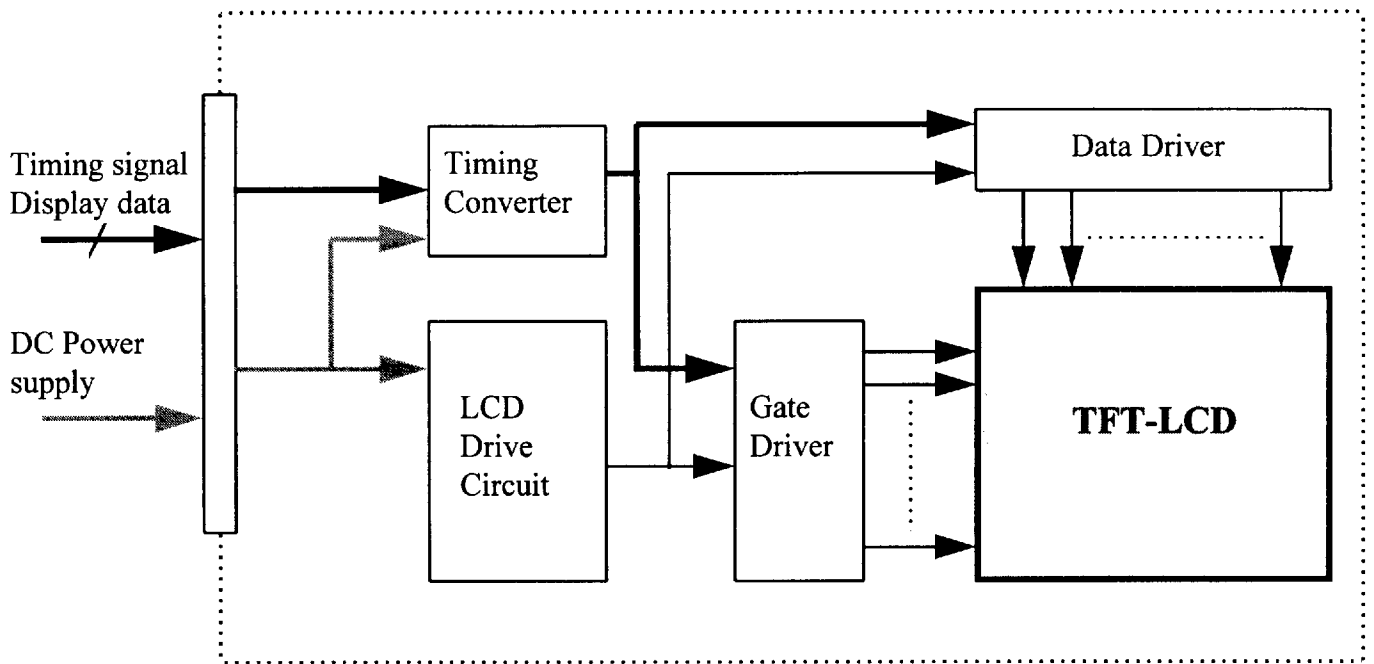

(2) BACK-LIGHT UNIT

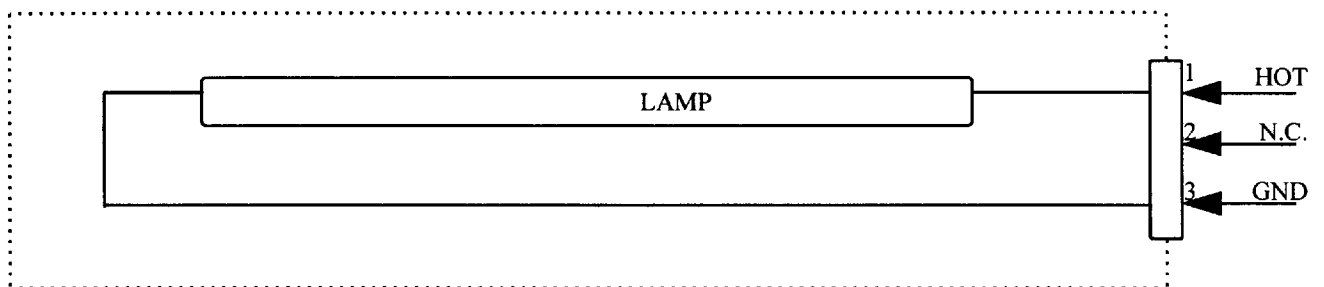

5. INPUT TERMINAL PIN ASSIGNMENT

(1) TFT LCD MODULE (interface signals & power) Connector : Hirose DF9-31P-1V

Pin NO.	Symbol	Function	Polarity	Note
1	GND	Power Ground	-	-
2	DCLK	Data Clock	-	(1)
3	HSYNC	Horizontal Sync Signal	Negative	-
4	VSYNC	Vertical Sync Signal	Negative	-
5	GND	Power Ground	-	-
6	R0	Red Data (LSB)	Positive	(2)
7	R1	Red Data	"	
8	R2	Red Data	"	
9	R3	Red Data	"	
10	R4	Red Data	"	
11	R5	Red Data [MSB]	"	
12	GND	Power Ground	-	-
13	G0	Green Data [LSB]	Positive	(2)
14	G1	Green Data	"	
15	G2	Green Data	"	
16	G3	Green Data	"	
17	G4	Green Data	"	
18	G5	Green Data [MSB]	"	
19	GND	Power Ground	-	-
20	B0	Blue Data [LSB]	Positive	(2)
21	B1	Blue Data	"	
22	B2	Blue Data	"	
23	B3	Blue Data	"	
24	B4	Blue Data	"	
25	B5	Blue Data [MSB]	"	
26	GND	Power Ground	-	-
27	DE [DTMG]	Data Enable [Display Timing]	Positive	-
28	VDD	Power Supply [+5V]	-	-
29	VDD	Power Supply [+5V]	-	-
30	VDD	Power Supply [+5V]	-	-
31	N.C.	No Connection	-	Open

Note (1). Display Data is sampled at the positive edge of Data Clock.

(2). Data level 0 means black data.

(2) BACK LIGHT UNIT

Connector : JST BHR-03VS-1

Pin NO.	Symbol	Function
1	HOT	High Voltage
2	N.C.	No Connection
3	GND	Ground

6. INTERFACE TIMING

6-1. Timing Parameters

Signal	Item	Symbol	Mode	MIN	TYP	MAX	Unit	Note	
Clock	Frequency	1 / T _c	ALL	-	25.175	28.322	MHz		
	High Time	T _{CH}	ALL	5	-	-	nsec		
	Low Time	T _{CL}	ALL	10	-	-	nsec		
Data	Setup Time	T _{DS}	ALL	5	-	-	nsec		
	Hold Time	T _{DH}	ALL	10	-	-	nsec		
Data Enable	Setup Time	T _{ES}	ALL	5	-	-	nsec	(1)	
Horizontal Sync	Cycle	T _H	ALL	-	31.78	-	usec		
			ALL	770	800	900	clock		
	Pulse Width	T _{HP}	ALL	-	96	-	clock		
Vertical Sync	Cycle	T _V	480	-	16.7	525	-	msec	lines
			400	-	14.3	449	-	msec	lines
			350	-	14.3	449	-	msec	lines
	Pulse Width	T _{VP}	480	1	2	30	lines		
			400	1	2	4	lines		
			350	1	2	4	lines		
Horizontal Signal	Display Start	T _{HS}	ALL	130	144	-	clock		
	Display period	T _{HD}	ALL	-	640	-	clock		
Vertical Signal	Display Start	T _{VS}	480	-	34	-	lines		
			400	-	34	-	lines		
			350	-	61	-	lines		
	Display Period	T _{VD}	480	-	480	-	lines		
			400	-	400	-	lines		
			350	-	350	-	lines		
Hsync - Vsync Phase Difference	Front	T _{VHD}	ALL	0	-	10	nsec		

Note (1). The duration of DE [DTMG] signal must be longer than 1 clock period at every horizontal period

(2). The 400 and 350 line mode is centered automatically in Sync mode but not in DE mode

6-2. Timing diagrams of interface signal

1) Display Signal Timing Diagram(480 Line Mode)

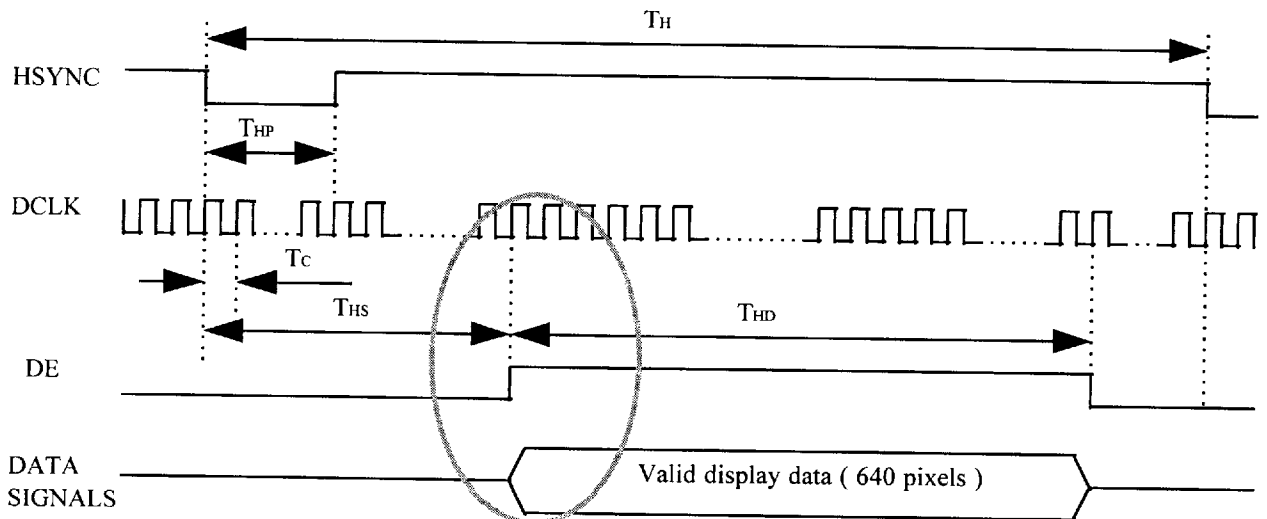
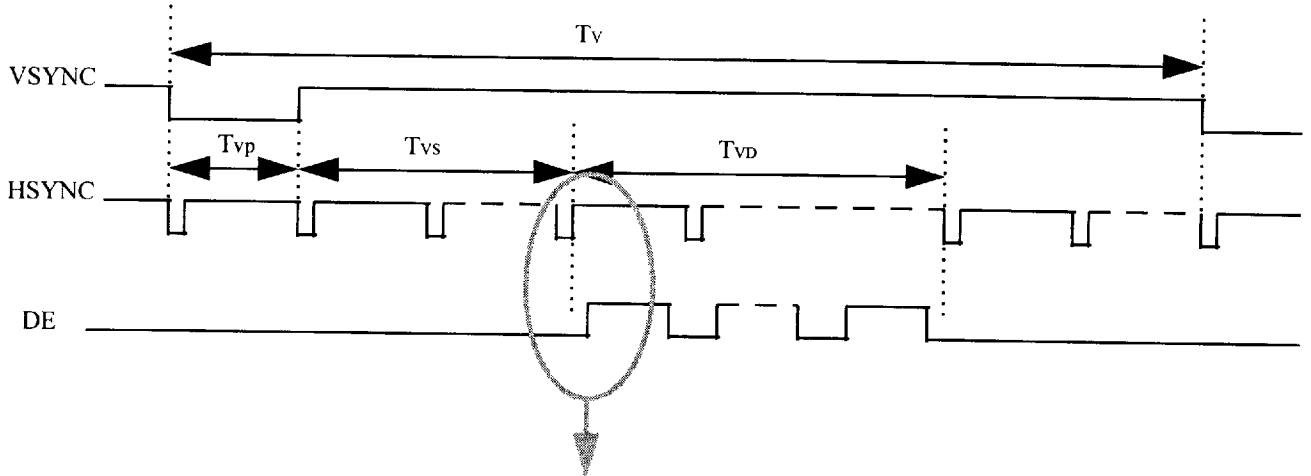

- Signal Transition Timing

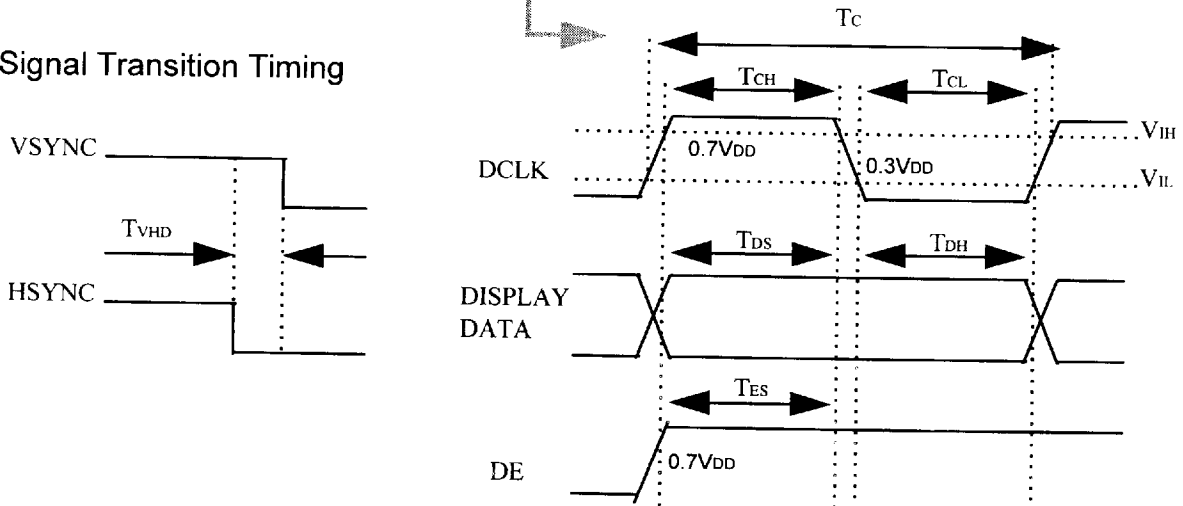

2) Display Signal Timing Diagram (400 Line Mode)

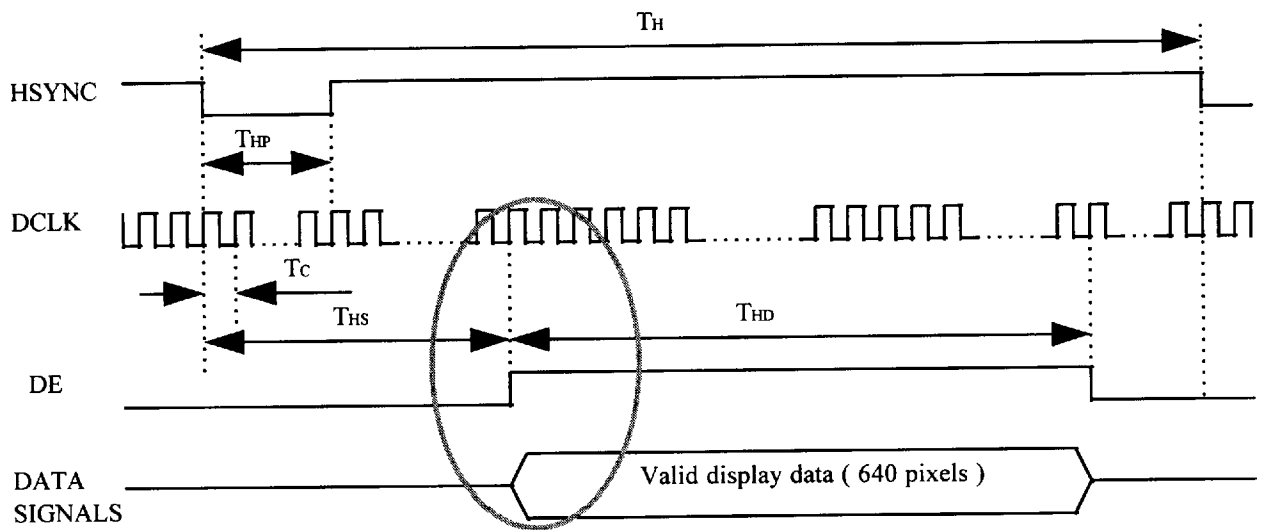
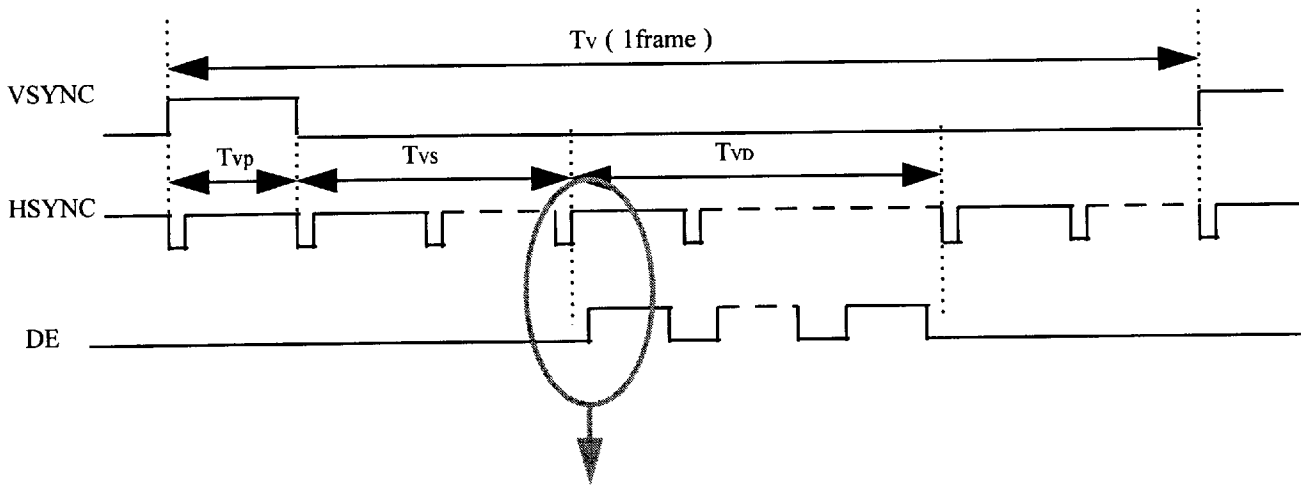

- Signal Transition Timing

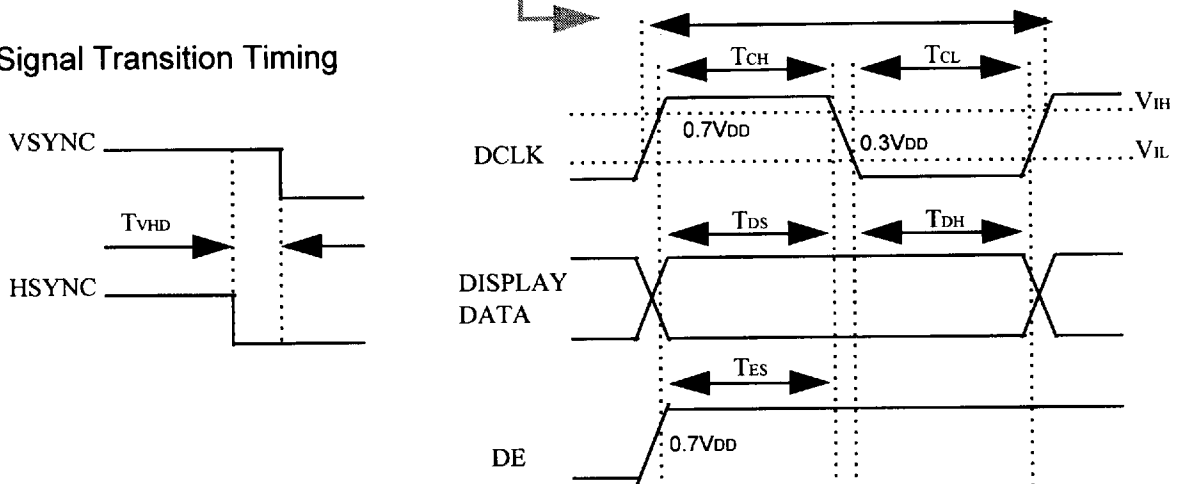

3) Display Signal Timing Diagram (350 Line Mode)

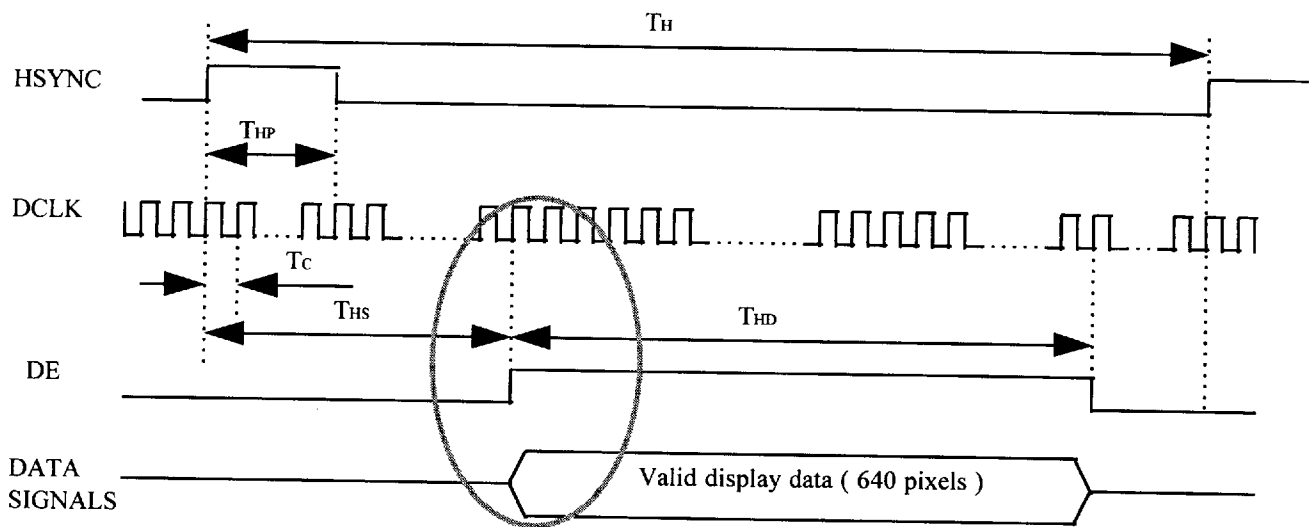
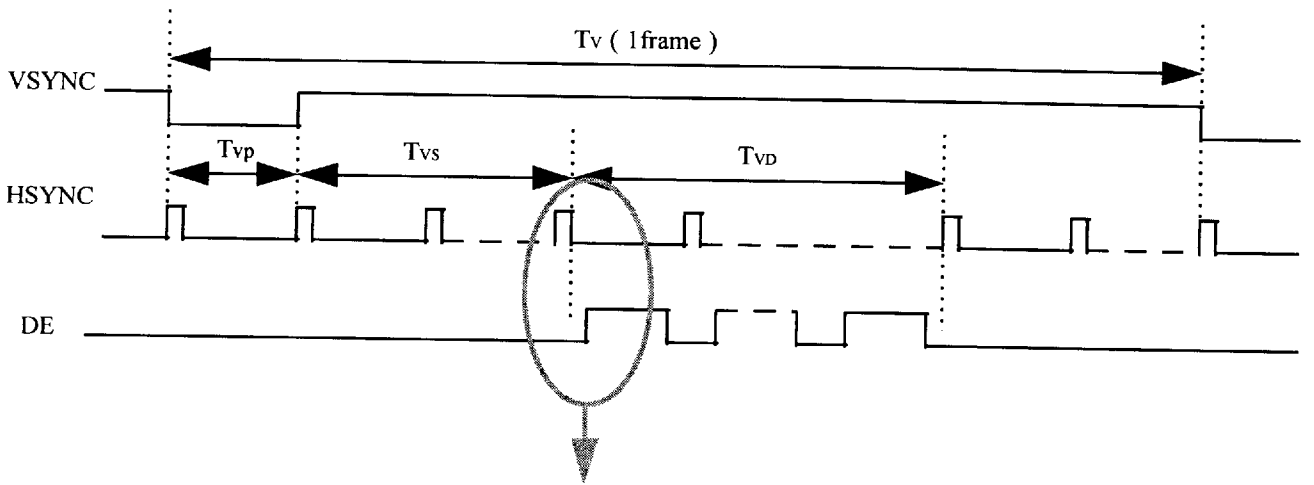

- Signal Transition Timing

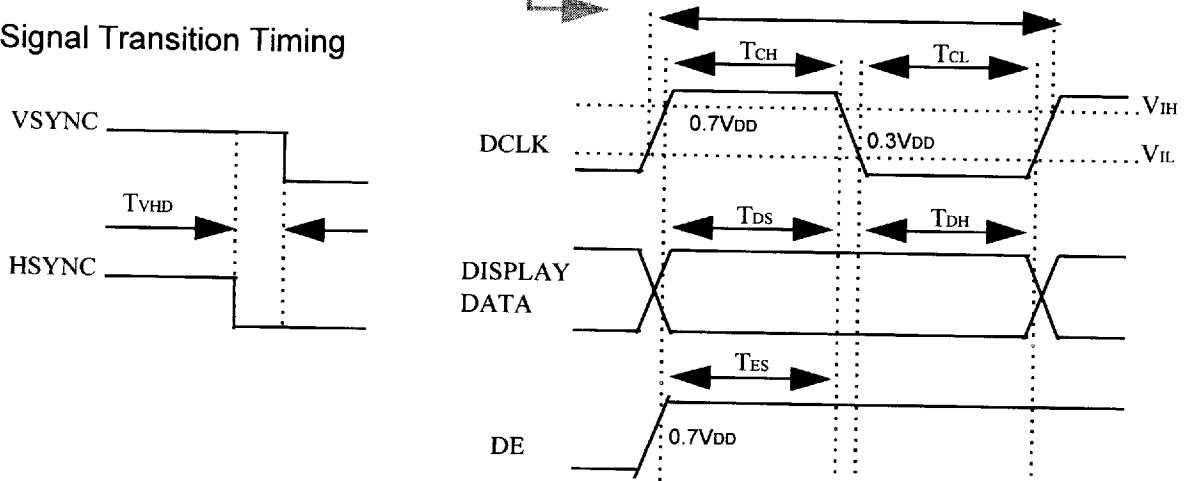

6-3. Power ON/OFF Sequence

: To prevent a latch-up or DC operation of the LCD module, the power on/off sequence shall be as shown below.

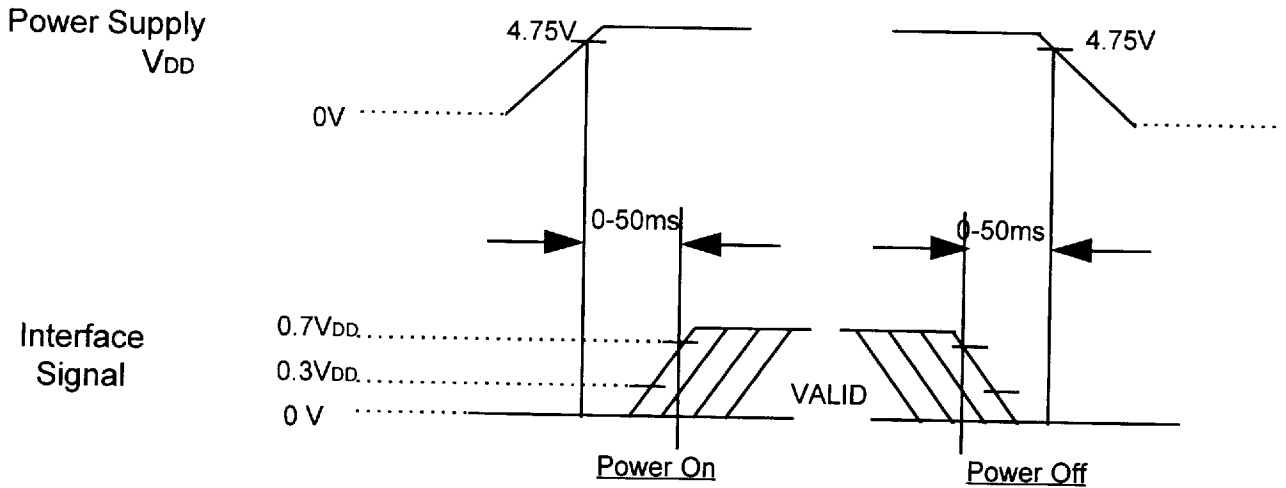

Power ON/OFF Sequence

*. Set $0\text{ V} < V_1(t) < V_{pp}(t)$

Here, $V_1(t)$, $V_{pp}(t)$ indicate the transit state of V_1 , V_{pp} when the power supply is turned ON or OFF

NOTE. Do not keep the interface signal high-impedance when power is on.

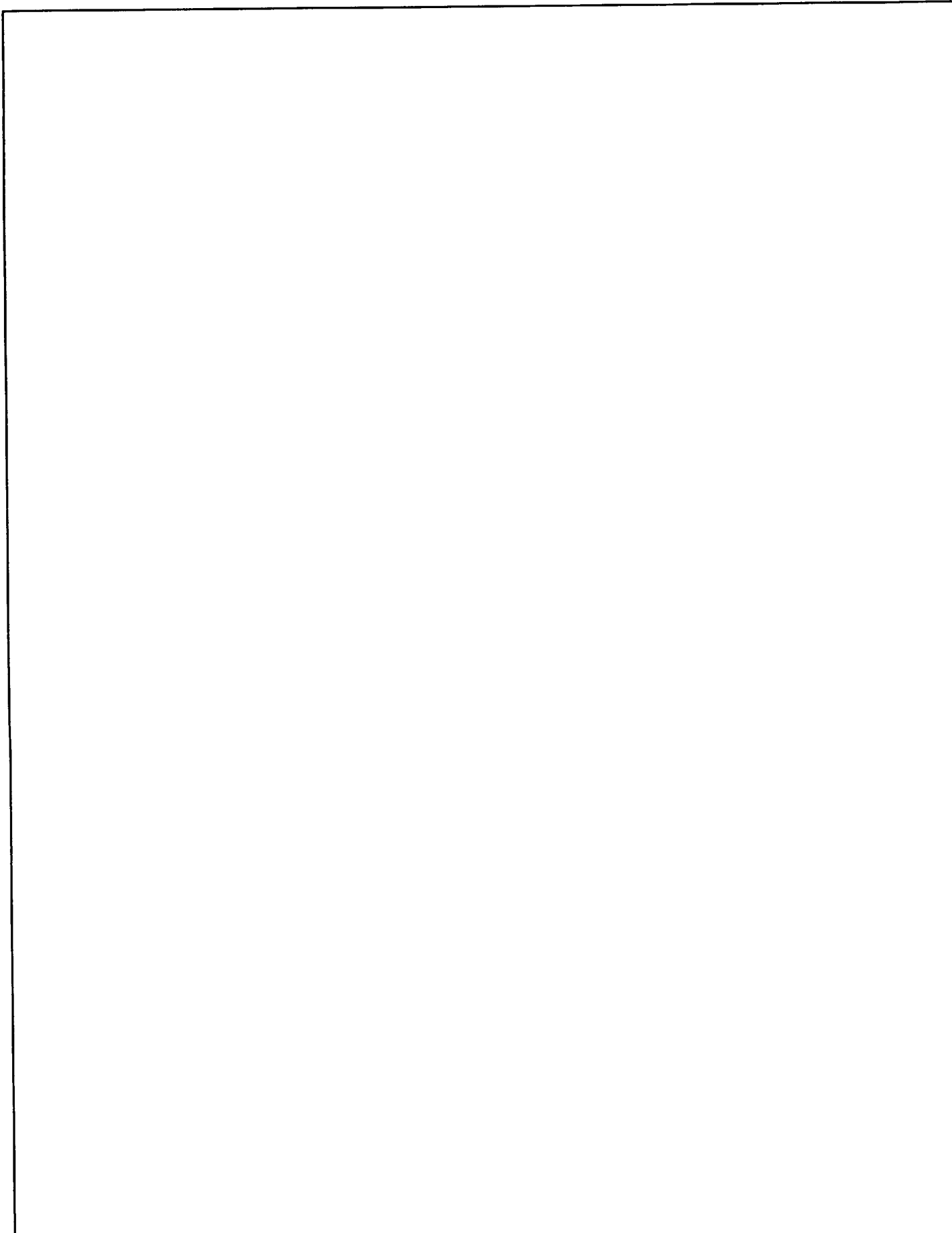

Doc.No.	LT104V3-100-01	Rev.No	0.0	Date	Mar.24.95	Page	17 /21
---------	----------------	--------	-----	------	-----------	------	--------

8. RELIABILITY TEST

No.	Test Item	Condition
1	High temperature storage test	Ta = 60 °C, 250hr
2	Low temperature storage test	Ta = 25 °C, 250hr
3	High temperature & high humidity operation test	Ta = 40 °C, 90%, 250hr (No condensation)
4	High temperature operation test	Ta = 50°C, Dynamic, 250hr
5	Low temperature operation test	Ta = 0 °C, Dynamic, 250hr
6	Vibration test (non-operatiing)	Frequency : 10 - 55 Hz Stroke : 1.5mm Test period : 6 hr (2hr for each direction of X,Y,Z)
7	Shock test (non-operating)	Max. gravity : 980 m/s ² Pulse width : 6ms, half sine wave Direction : ± X, ± Y, ± Z One time for each direction
8	Thermal shock	-20°C (0.5 hr) 60°C (0.5hr) 50 Cycle
9	Electrostatic Discharge Test	200 pF, 0 ohm ± 200V(Terminal) ± 5000V(Chassis & Panel)

[Result Evaluation Criteria]

Under the display quality test conditions with normal operation state, these shall be no change which may affect practical display function.

9. PACKING, TRANSPORTATION, AND DELIVERY

Supplier will pack products to be delivered to customer in accordance with supplier's packing specifications, and will deliver them to customer in such a state that they will not suffer damage during transportation. The delivery conditions are as follows.

(1) Outer box

As shown in the figure, one or two inner boxes are packed in an outer box.

There is a risk of damage to the products if the outer box is dropped from a height of 70cm or more, and therefore care should be taken in handling the box during transportation.

When a box is stored in a warehouse, etc., care should be taken to ensure that the storage temperature is not exceeded.

(2) Inner box

The parts number and quantity are shown on the inner box, either printed directly or on a label.

Products should not be transported in the inner box alone, since there is a risk of damage. Moisture-proofing material silicagel is to be placed on the inner boxes, and they are then to be covered in moisture-proof vinyl sheet.

(3) Means of transportation

Products are to be transported by hand, light van, truck, by air

Doc.No.	LT104V3-100-01	Rev.No	0.0	Date	Mar.24.95	Page	19 /21
---------	----------------	--------	-----	------	-----------	------	--------

10. MARKINGS

A nameplate bearing the following information is affixed to a shipped product at the specified location on each product.

(1) Parts number : 1AA 000 - 00 - 00

(2) Revision : One letter

(3) Control code : One letter

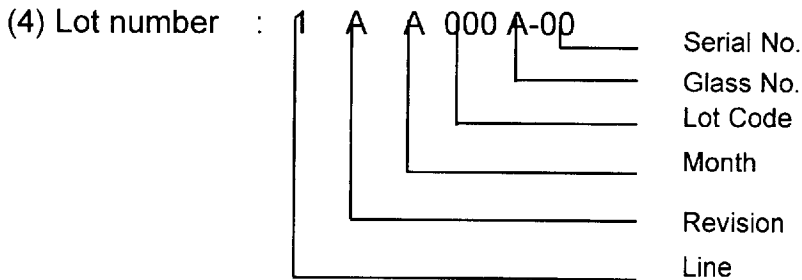

(5) Indication examples Nameplate

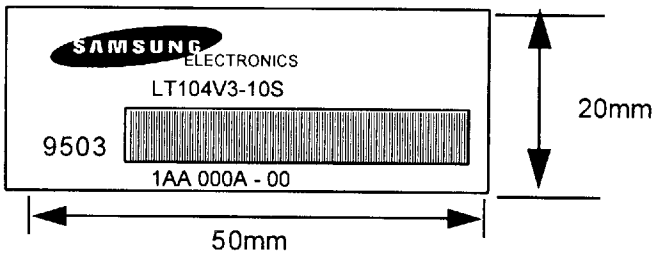

Parts name
Lot number
Inspection work week

High voltage caution label

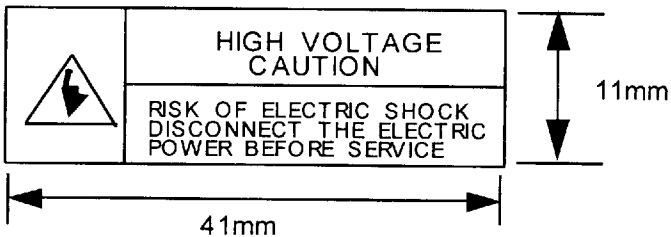

High voltage caution

11. PRODUCT INSPECTION

When products are shipped, incoming inspection shall be carry out with a sampling inspection based on MIL-STD-105E level II by AQL 1.0%.

CHANGE CONTROL

Design changes may be made for this product relating to the specifications, appearance, parts used, circuits, etc., for the purpose of product improvement. If a design change is judged to affect the specifications of this product, supplier shall inform customer of the change in advance.

QUALITY CONTROL

In the event of a product failure under normal operating conditions, and in the event of product trouble or a functional disorder that can be deemed to be the responsibility of supplier, supplier shall repair the fault or replace the product free of charge within one year of the product delivery date. However, supplier shall not bear responsibility for the quality of a product in the case of modifications other than those specified by supplier.

MAINTENANCE

The specifications of the functions of maintenance parts may be partially changed with in a range which provides for equivalent or better quality. Maintenance parts shall in principle be product units. If manufacture of this product is stopped, supplier shall notify customer in advance.

HANDLING OF DOUBTFUL POINTS

If any doubt arises concerning a matter not stipulated in this specification, the matter is to be resolved by mutual agreement between customer and supplier, and supplier shall make efforts for improvement in good faith.

Doc.No.	LT104V3-100-01	Rev.No	0.0	Date	Mar.24.95	Page	21 /21
---------	----------------	--------	-----	------	-----------	------	--------

12. Handling Precautions

1. Be sure to turn off the power supply when inserting or disconnecting the cable.
2. Others
 - a) Be sure to design the cabinet so that the module can be installed without any extra stress such as wrap or twist.
 - b) Since the front polarizer is easily damaged. pay attention not to scratch it.
 - c) Wipe off water drop immediately. Long contact with water may cause discoloration or spot
 - d) When the panel surface become solid, wipe it with absorbent cotton or other soft cloth.
 - e) Since the panel is made of glass, it may break or crack if dropped or bumped on hard surface. Handle with care
 - f) Since CMOS LSI is used in this module, take care of static electricity and injure the human earth when handling
 - g) Observe all other precautionary requirements in handling components.

Doc.No.	LT104V3-100-01	Rev.No	0.0	Date	Mar.24.95	Page	22 /21
---------	----------------	--------	-----	------	-----------	------	--------