

# THOMSON-EFCIS

## Integrated Circuits

TEA 2014

### ADVANCE INFORMATION

#### VIDEO SWITCHING CIRCUIT FOR TV

This integrated circuit provides all video switching allowing connections between the peri TV plug and video sections in the TV set. The TEA 2014 is supplied in a 8 leads case CB-98.

#### Main features

- 1 video output  $75 \Omega$  - 1 Vpp no switched
- 1 switched video output 2 Vpp
- Video cross talk : 50 db typical
- Short circuit protection of inputs and outputs
- Clamped video inputs.

#### VIDEO SWITCHING

#### CASE CB-98



DP SUFFIX  
PLASTIC PACKAGE

#### TYPICAL APPLICATION AND TEST CIRCUIT

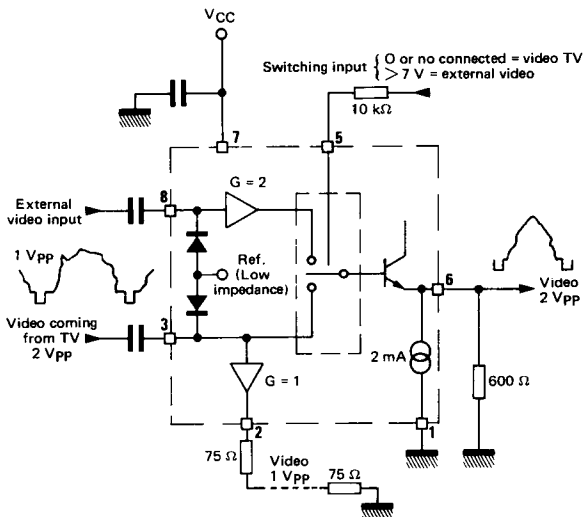

We advice to protect the  $75 \Omega$  output through a  $75 \Omega$  resistor for supply voltage upper than 9 V.

#### PIN ASSIGNMENT

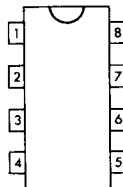

- 1 - Ground
- 2 -  $75 \Omega$  video output
- 3 - Internal video input
- 4 - Not to be used
- 5 - Switching input
- 6 - Switched video output
- 7 - Supply voltage
- 8 - External video input

#### THOMSON-EFCIS

Sales headquarters  
45, av. de l'Europe - 78140 VELIZY - FRANCE  
Tel. : (3) 946 97 19 / Telex : 204780 F

 **THOMSON-CSF**  
COMPONENTS

SP8213-A 1/3

## MAXIMUM RATINGS

Rating	Symbol	Value	Unit
Supply voltage	V <sub>CC</sub>	18	V
Operating temperature with load > 150 Ω with load = 75 Ω	T <sub>oper</sub>	-10,+ 100 -10,+ 70	°C
Junction temperature	T <sub>j</sub>	-40,+ 150	°C
Storage temperature	T <sub>stg</sub>	-40,+ 150	°C
Minimum DC load resistor P6		600	Ω
Minimum DC load resistor P2		75	Ω

## THERMAL CHARACTERISTICS

Characteristic	Symbol	Value	Unit
Junction-ambient thermal resistance	R <sub>th(j-a)</sub>	90 typ.	°C/W

## ELECTRICAL CHARACTERISTICS

T<sub>amb</sub> = + 25°C, V<sub>CC</sub> = 9 V (unless otherwise noted)

Characteristic	Symbol	Min	Typ	Max	Unit
Supply voltage range	V <sub>CC</sub>	8	—	14	V
Supply current (no load on pin 2 and pin 6)	I <sub>CC</sub>	—	—	20	mA
Supply current (with 75 Ω between pin 2-1, with 600 Ω between pin 6-1)	I <sub>CC</sub>	—	75	—	mA
Total power dissipation with load	P <sub>tot</sub>	—	450	—	mW
Internal video input swing from picture F1 (Positive video)	—	—	—	4.5	V <sub>pp</sub>
Internal video input impedance (Positive video)	—	50	—	—	KΩ
Internal video input bias current (Positive video)	—	10	25	40	μA
External video input swing (Positive video)	—	—	—	2	V <sub>pp</sub>
External video input impedance (positive video)	—	50	—	—	KΩ
Switched video output swing	—	—	—	4.5	V <sub>pp</sub>
Switched video output dynamic impedance	—	—	—	20	Ω
Switched video DC output voltage (Sync. pulse level, note 1) (600 Ω)	—	1,7	2	2,4	V
Switched video band width (-1 dB)	—	6	—	—	MHz
Switched video output gain	—	—	—	—	dB
Pin 6 - pin 8 (gain with 600 Ω load)	—	+ 4	+ 5	+ 6	
Pin 6 - pin 3 (gain with 600 Ω load)	—	-1	-0.5	0	
External video output swing (with 75 Ω load)	—	—	2	2,2	V
External video dynamic output impedance	—	—	10	—	Ω
External video DC output voltage (Sync. pulse level, note 1) (75 Ω)	—	1,7	2	2,4	V
External video output gain (Pin 2 - pin 3 gain with 75 Ω load)	—	-1,8	-1	-0,4	dB
Switching input unactive low level or unconnected pin (TV receiving)	—	0	—	3	V
Switching input active level (ext. receiving)	—	7	—	V <sub>CC</sub>	V
Switching input impedance	—	10	—	—	KΩ
Video rejection between two inputs	—	—	—	—	dB
0 to 5 MHz	—	—	-50	—	
1 KHz	—	-50	—	—	
Differential group delay	—	—	15	—	ns
Linearity distortion	—	—	—	—	%
Luma (test line 17)	—	—	2	—	
Chroma (test line 331)	—	—	2	—	
Intermodulation Luma - Chroma (test line 331)	—	—	5	—	
Supply voltage rejection (1 KHz)	—	40	50	—	dB

Note 1 : Use a video signal with a synchro pulse in order to make the clamp work in a correct way (75 Ω to the ground and 10 μF in serie).

## CASE CB-98



DP SUFFIX  
PLASTIC PACKAGE

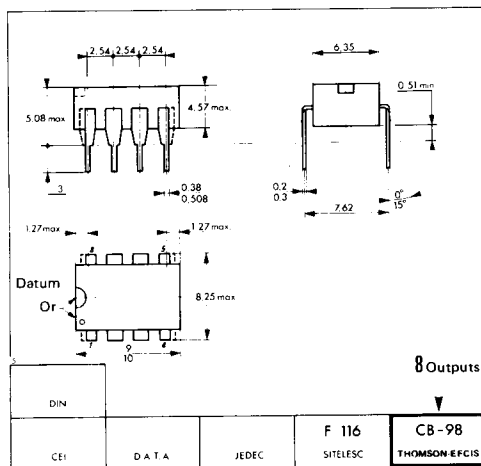

This is advance information and specifications are subject to change without notice.  
Please inquire with our sales offices about the availability of the different packages.