

MAS9162

80 mA LDO Voltage Regulator IC

This is preliminary information on a new product under development. Micro Analog Systems Oy reserves the right to make any changes without notice.

Preliminary

- **Low Noise, 30 μ Vrms, without External Bypass Capacitor**
- **Very Short Start-up Time: 10 μ s**
- **Stable Low-ESR Output Capacitors**
- **Low Minimum Output Capacitance Requirement: 0.22 μ F**
- **Regulator Enable/Disable Control**

DESCRIPTION

MAS9162 is a low dropout voltage regulator with an enable/disable pin, which allows device to be turned off or on by pulling control to low or high.

No external bypass capacitor is needed for achieving the low noise level of 30 μ Vrms. In addition to the noise levels, MAS9162 excels in dropout voltage (95 mV typical at 50 mA) and in start-up time (typically 10 μ s from start-up to within $\pm 1\%$ of $V_{OUT(NOM)}$).

The Equivalent Series Resistance (ESR) range of output capacitors that can be used with MAS9162 is very wide. This ESR range from a few m Ω up to a couple of Ohms combined with no minimum output

current requirement makes the usage of MAS9162 easier and low in cost. Also the minimum output capacitance requirement is very low. This combined with very short start-up time makes it possible to switch the regulator off and on even in timing critical and/or noise sensitive applications.

An internal thermal protection circuit prevents the device from overheating. Also the maximum output current is internally limited. In order to save power the device goes into sleep mode when the regulator is disabled.

FEATURES

- No External Bypass Capacitor Needed
- Optimized for Fast Start-up
- Internal Thermal Shutdown
- Short Circuit Protection
- SOT23-5 Package
- Pin Compatible with MC33761
- Several Output Voltage Options Available, See Ordering Information p. 8

APPLICATION

- RF-Oscillators
- Cellular Phones
- Cordless Phones
- Pagers
- Battery Powered Systems
- Portable Systems
- Radio Control Systems

PIN CONFIGURATION

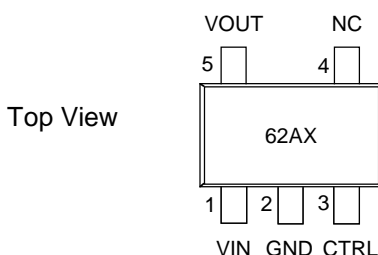

For Top Marking Information see Ordering Information p. 8

PIN DESCRIPTION

Pin Name	Pin	Type	Function
VIN	1	P	Power Supply Voltage
GND	2	G	Ground
CTRL	3	I	Enable/Disable Pin for Regulator
N/C	4	-	Not Connected
VOUT	5	O	Output

G = Ground, I = Input, O = Output, P = Power

BLOCK DIAGRAM

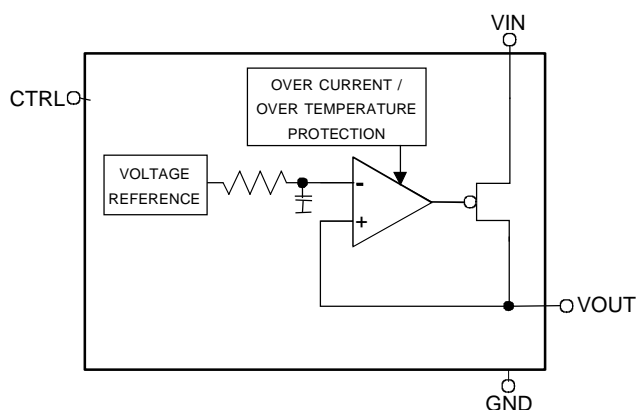

ABSOLUTE MAXIMUM RATINGS

All voltages with respect to ground.

Parameter	Symbol	Conditions	Min	Max	Unit
Supply Voltage	V_{IN}		-0.3	6	V
Voltage Range for All Pins			-0.3	$V_{IN} + 0.3$	V
ESD Rating		HBM		2	kV
Junction Temperature	T_{Jmax}			+175 (limited)	°C
Storage Temperature	T_S		-55	+150	°C

Stresses beyond those listed may cause permanent damage to the device. The device may not operate under these conditions, but it will not be destroyed.

RECOMMENDED OPERATING CONDITIONS

Parameter	Symbol	Conditions	Min	Max	Unit
Operating Junction Temperature	T_J		-40	+125	°C
Operating Ambient Temperature	T_A		-40	+85	°C
Operating Supply Voltage	V_{IN}		$V_{OUT(NOM)} + 0.3$	5.3	V

ELECTRICAL CHARACTERISTICS

$T_A = -40^{\circ}\text{C}$ to $+85^{\circ}\text{C}$, typical values at $T_A = +27^{\circ}\text{C}$, $V_{IN} = V_{OUT(NOM)} + 1\text{ V}$, $I_{OUT} = 1\text{ mA}$, $C_{IN} = 1\text{ }\mu\text{F}$, $C_{OUT} = 1.0\text{ }\mu\text{F}$, $V_{CTRL} = 2\text{ V}$, unless otherwise specified.

◆ Thermal Protection

Parameter	Symbol	Conditions	Min	Typ	Max	Unit
Threshold High	T_H		145	160	175	$^{\circ}\text{C}$
Threshold Low	T_L		135	150	165	$^{\circ}\text{C}$

The hysteresis of 10°C prevents the device from turning on too soon after thermal shut-down.

◆ Control Terminal Specifications

Parameter	Symbol	Conditions	Min	Typ	Max	Unit
Control Voltage OFF State ON State	V_{CTRL}		1.6		0.55	V
Control Current	I_{CTRL}	$V_{CTRL} = V_{IN}$ $V_{CTRL} = 0\text{ V}$		5 0	15	μA

◆ Voltage Parameters

Parameter	Symbol	Conditions	Min	Typ	Max	Unit
Output Voltage Tolerance	V_{OUT}	$I_{OUT} = 0\text{ mA}$ $I_{OUT} = 50\text{ mA}$	- 1.7 - 3.5		+ 1.7 + 1.7	$\%V_{OUT(NOM)}$
Dropout Voltage	V_{DROP}	$I_{OUT} = 1\text{ mA}$ $I_{OUT} = 10\text{ mA}$ $I_{OUT} = 50\text{ mA}$		46 51 95		mV

◆ Current Parameters

Parameter	Symbol	Conditions	Min	Typ	Max	Unit
Continuous Output Current	I_{OUT}		0		80	mA
Short Circuit Current	I_{MAX}	$R_L = 0\text{ }\Omega$		230		mA
Peak Output Current	I_{PK}	$V_{OUT} > 95\% * V_{OUT(NOM)}$		180		mA
Ground Pin Current	I_{GND}	$I_{OUT} = 0\text{ mA}$ $I_{OUT} = 10\text{ mA}$ $I_{OUT} = 50\text{ mA}$		170 210 250		μA
Ground Pin Current, Sleep Mode	I_{GND}	$V_{CTRL} < 0.3\text{ V}$	$T_A = 25^{\circ}\text{C}$	0.02	0.5	μA
			$T_A = 85^{\circ}\text{C}$	0.2	2	

◆ Power Dissipation

Parameter	Symbol	Conditions	Min	Typ	Max	Unit
Thermal Resistance (Junction-to-Air)	R_{JA}	typical PC board mounting, still air		255.9		°C/W
Maximum Power Dissipation	P_d	any ambient temperature	$P_{dMAX} = \frac{T_{J(MAX)} - T_A}{R_{JA}}$ Note 1			W

Note 1: $T_{J(MAX)}$ denotes maximum operating junction temperature (+125°C), T_A ambient temperature, and R_{JA} junction-to-air thermal resistance (+255.9°C/W).

◆ Line and Load Regulation

Parameter	Symbol	Conditions	Min	Typ	Max	Unit
Line Regulation		$V_{OUT(NOM)} + 1\text{ V} < V_{IN} < 5.3\text{ V}$ $I_{OUT} = 50\text{ mA}$		0.75	2	mV
Load Regulation		$I_{OUT} = 1.0\text{ to }50\text{ mA}$		13.5	25	mV

◆ Noise and Ripple Rejection

Parameter	Symbol	Conditions	Min	Typ	Max	Unit
Output Noise Voltage	V_{RMS}	100 Hz < f < 100 kHz		30		μVrms
Noise Density	V_N	$I_{OUT} = 50\text{ mA}$, f = 10 kHz		140		$\frac{\text{nV}}{\text{sqrt(Hz)}}$
PSRR		f = 1 kHz f = 10 kHz f = 100 kHz		50 38 37		dB

◆ Dynamic Parameters

Parameter	Symbol	Conditions	Min	Typ	Max	Unit
Start-up Delay (from start-up to 80% of $V_{OUT(NOM)}$)		$V_{CTRL} = 0\text{ to }2.4\text{ V}$, $I_{OUT} = 50\text{ mA}$, $C_L \leq 1.0\text{ }\mu\text{F}$		6.5		μs
Overshoot		$V_{CTRL} = 0\text{ to }2.4\text{ V}$		2.0	8.0	%
Start-up Time (settling time of voltage transient from start-up to within ±1% of $V_{OUT(NOM)}$)		$V_{CTRL} = 0\text{ to }2.4\text{ V}$, $I_{OUT} = 50\text{ mA}$, $C_L \leq 1.0\text{ }\mu\text{F}$		10		μs

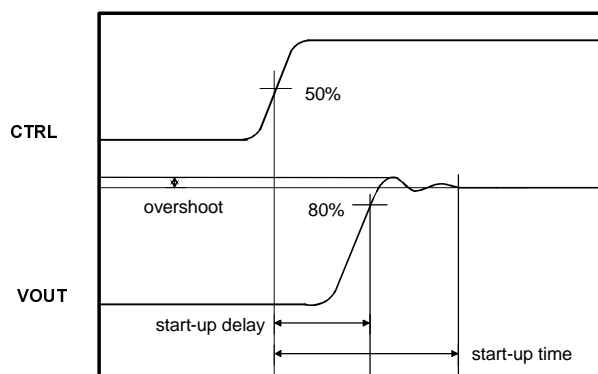
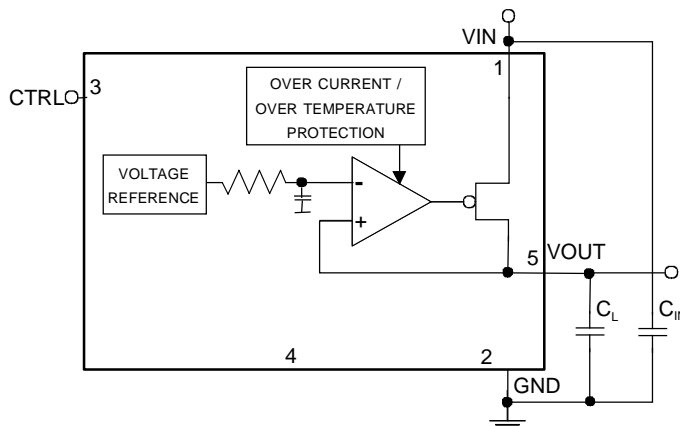

Figure1. Definitions of start-up delay, overshoot and start-up time.

APPLICATION INFORMATION

Parameter	Symbol	Min	Typ	Max	Unit	Note
Output Capacitance	C_L	0.22	1.0		μF	<ol style="list-style-type: none"> 1. Ceramic and film capacitors can be used. 2. The value of C_L should be smaller than or equal to the value of C_{IN}.
Effective Series Resistance	ESR	0.01		2	Ohm	<ol style="list-style-type: none"> 1. When within this range stable with all $I_{OUT} = 0 \text{ mA} \dots 80 \text{ mA}$ values.
Input Capacitance	C_{IN}	0.5			μF	<ol style="list-style-type: none"> 1. A big enough input capacitance is needed to prevent possible impedance interactions between the supply and MAS9162. 2. Ceramic, tantalum, and film capacitors can be used. If a tantalum capacitor is used, it should be checked that the surge current rating is sufficient for the application. 3. In the case that the inductance between a battery and MAS9162 is very small ($< 0.1 \mu\text{H}$) $0.47 \mu\text{F}$ input capacitor is sufficient. 4. The value of C_{IN} should not be smaller than the value of C_L.

Values given on the table are minimum requirements unless otherwise specified. When selecting capacitors, tolerance and temperature coefficient must be considered to **make sure that the requirement is met in all potential operating conditions.**

PACKAGE (SOT23_5) OUTLINE

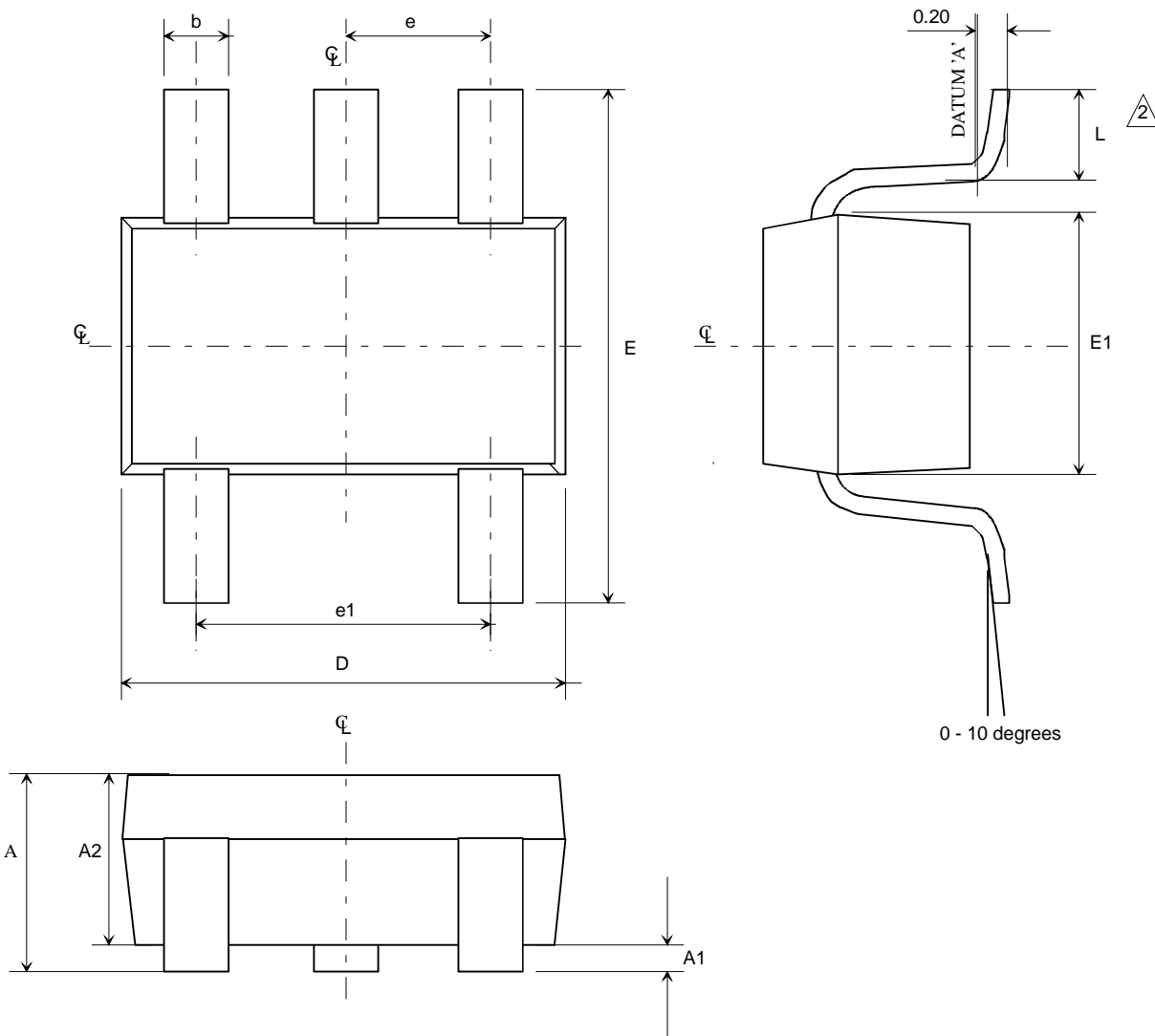

- NOTE:
1. ALL DIMENSIONS ARE IN MILLIMETERS
 2. FOOT LENGTH MEASURED AT INTERCEPT POINT BETWEEN DATUM A & LEAD SURFACE.
 3. PACKAGE OUTLINE EXCLUSIVE OF MOLD FLASH & METAL BURR
 4. PACKAGE OUTLINE INCLUSIVE OF SOLDER PLATING.
 5. COMPLY TO EIAJ SC74

Symbol	Min	Max	Unit
A	0.90	1.45	mm
A1	0.00	0.15	mm
A2	0.90	1.30	mm
b	0.25	0.50	mm
C	0.09	0.20	mm
D	2.80	3.10	mm
E	2.60	3.00	mm
E1	1.50	1.75	mm
L	0.35	0.55	mm
e	0.95ref		mm
e1	1.90ref		mm

SOLDERING INFORMATION

Resistance to Soldering Heat	According to RSH test IEC 68-2-58/20 2*220°C
Maximum Reflow Temperature	235°C
Maximum Number of Reflow Cycles	2
Seating Plane Co-planarity	max 0.08 mm
Lead Finish	Solder plate 7.62 - 25.4 μm, material Sn 85% Pb 15%

TAPE & REEL SPECIFICATIONS

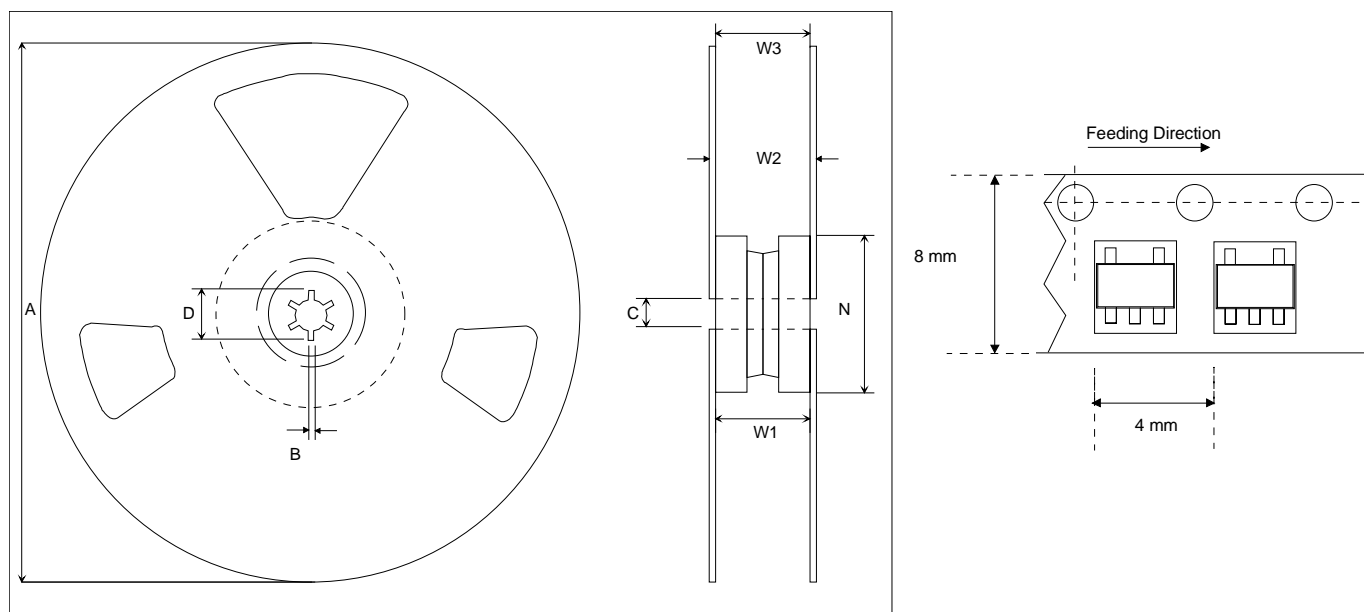

Other Dimensions according to EIA-481 Standard

3000 Components on Each Reel

Dimension	Min	Max	Unit
A		178	mm
B	1.5		mm
C	12.80	13.50	mm
D	20.2		mm
N	50		mm
W ₁ (measured at hub)	8.4	9.9	mm
W ₂ (measured at hub)		14.4	mm
Trailer	160		mm
Leader	390, of which minimum 160 mm of empty carrier tape sealed with cover tape		mm

ORDERING INFORMATION

Product Code	Product	Top Marking	Package	Comments
MAS9162AST1-T	3.30 V Voltage Regulator IC	62A1	SOT23-5	Tape and Reel
MAS9162AST2-T	2.80 V Voltage Regulator IC	62A2	SOT23-5	Tape and Reel
MAS9162AST3-T	2.50 V Voltage Regulator IC	62A3	SOT23-5	Tape and Reel
MAS9162AST6-T	3.00 V Voltage Regulator IC	62A6	SOT23-5	Tape and Reel
MAS9162AST7-T	2.90 V Voltage Regulator IC	62A7	SOT23-5	Tape and Reel
MAS9162AST8-T	2.86 V Voltage Regulator IC	62A8	SOT23-5	Tape and Reel
MAS9162AST9-T	2.70 V Voltage Regulator IC	62A9	SOT23-5	Tape and Reel

For more voltage options contact Micro Analog Systems Oy.

LOCAL DISTRIBUTOR

MICRO ANALOG SYSTEMS OY CONTACTS

Micro Analog Systems Oy Kamreerintie 2, P.O.Box 51 FIN-02771 Espoo, FINLAND Http://www.mas-oy.com	Tel. (09) 80 521 Tel. Int. +358 9 80 521 Telefax +358 9 805 3213 E-mail: info@mas-oy.com
--	--

NOTICE

Micro Analog Systems Oy reserves the right to make changes to the products contained in this data sheet in order to improve the design or performance and to supply the best possible products. Micro Analog Systems Oy assumes no responsibility for the use of any circuits shown in this data sheet, conveys no license under any patent or other rights unless otherwise specified in this data sheet, and makes no claim that the circuits are free from patent infringement. Applications for any devices shown in this data sheet are for illustration only and Micro Analog Systems Oy makes no claim or warranty that such applications will be suitable for the use specified without further testing or modification.