



LB11975

High-Speed CD-ROM Spindle Motor Driver IC

Overview

The LB11975 is a monolithic bipolar IC developed for uses as a spindle motor driver for high-speed CD-ROM and DVD-ROM drives. To minimize heat generation during high-speed rotation and braking, the LB11975 adopts direct PWM drive in the output stage. During reverse braking the upper and lower side output transistors are both driven in PWM mode to implement dual PWM controlled braking. The device thus controls the current to remain under a limit value and prevent rapid heat generation. This prevents device destruction due to rapid heating. The absolute maximum voltage rating is 27 V, and the maximum current is 2.5 A.

Functions and Features

- Direct PWM drive (lower side control)
- Built-in upper and lower side output diodes
- Supports the use 3.3 V DSP devices.
- Power saving function for standby mode
- Hall FG output (1 or 3 Hall device operation)
- Built-in Hall device power supply
- Reverse rotation detection output and drive cutoff circuit
- Voltage control amplifier
- Current limiter circuit
- Thermal protection circuit

Package Dimensions

unit: mm

3251-HSOP36R

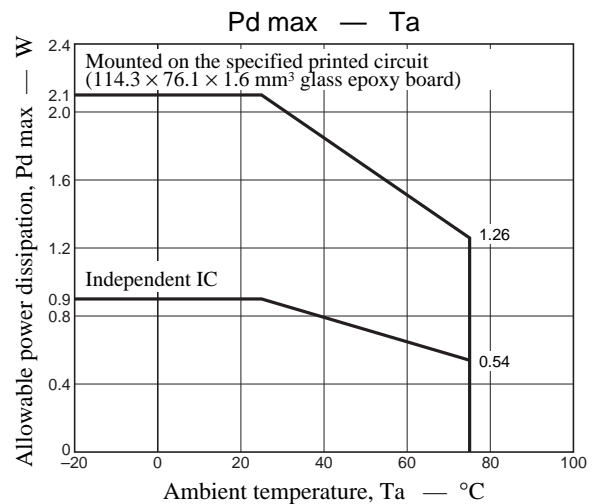
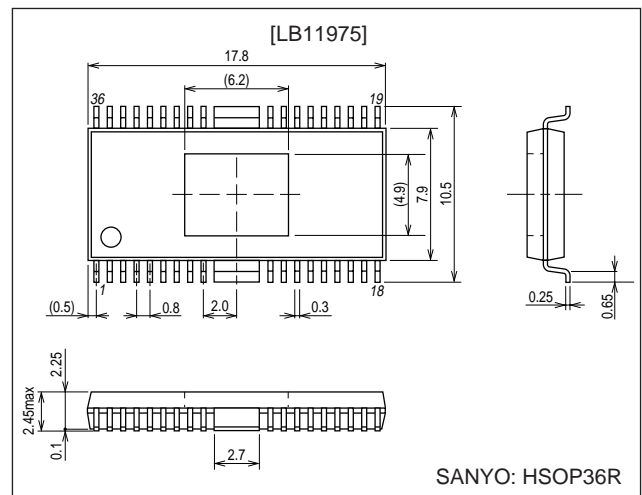

■ Any and all SANYO products described or contained herein do not have specifications that can handle applications that require extremely high levels of reliability, such as life-support systems, aircraft's control systems, or other applications whose failure can be reasonably expected to result in serious physical and/or material damage. Consult with your SANYO representative nearest you before using any SANYO products described or contained herein in such applications.

■ SANYO assumes no responsibility for equipment failures that result from using products at values that exceed, even momentarily, rated values (such as maximum ratings, operating condition ranges, or other parameters) listed in products specifications of any and all SANYO products described or contained herein.

Specifications

Maximum Ratings at $T_a = 25^\circ\text{C}$

Parameter	Symbol	Conditions	Ratings	Unit
Supply voltage 1	V_{CC1} max		7	V
Supply voltage 2	V_{CC2} max		27	V
Supply voltage 3	V_{CC3} max		27	V
Output current	I_O max		2.5	A
Output applied voltage	V_{IN} max		30	V
Allowable power dissipation 1	P_d max1	Independent IC	0.9	W
Allowable power dissipation 2	P_d max2	Mounted on the specified circuit board ($114.3 \times 76.1 \times 1.6$ mm ³ glass epoxy board)	2.1	W
Operating temperature	T_{opr}		-20 to +75	$^\circ\text{C}$
Storage temperature	T_{stg}		-55 to +150	$^\circ\text{C}$

Allowable Operating Ranges at $T_a = 25^\circ\text{C}$

Parameter	Symbol	Conditions	Ratings	Unit
Power-supply voltage range 1	V_{CC1}		4 to 6	V
Power-supply voltage range 2	V_{CC2}	$V_{CC2} \geq V_{CC1}$	4 to 16	V
Power-supply voltage range 3	V_{CC3}		4 to 16	V
FG pin applied voltage	V_{FG}		0 to V_{CC1}	V
FG pin output current	I_{FG}		0 to 4.0	mA

Electrical Characteristics at $T_a = 25^\circ\text{C}$, $V_{CC1} = 5\text{ V}$, $V_{CC2} = V_S = 12\text{ V}$

Parameter	Symbol	Conditions	Ratings			Unit
			min	typ	max	
Supply current 1	I_{CC1-1}	$V_{CTL} = V_{CREF}$	5.0	8.0	11.0	mA
	I_{CC1-2}	$V_S/S = 0\text{ V}$		0	200	μA
Supply current 2	I_{CC2-1}	$V_{CTL} = V_{CREF}$	5.0	6.5	8.0	mA
	I_{CC2-2}	$V_S/S = 0\text{ V}$		0	200	μA
Supply current 3	I_{CC3-1}	$V_{CTL} = V_{CREF}$		0.3	0.7	mA
	I_{CC3-2}	$V_S/S = 0\text{ V}$		0	200	μA
[Output Block]						
Output saturation voltage 1	$V_{Osat1(L)}$	$I_O = 0.5\text{ A}$, $V_O(\text{sink})$, $V_{CC1} = 5\text{ V}$, $V_{CC2} = V_{CC3} = 12\text{ V}$		0.15	0.25	V
	$V_{Osat1(H)}$	$I_O = 0.5\text{ A}$, $V_O(\text{source})$, $V_{CC1} = 5\text{ V}$, $V_{CC2} = V_{CC3} = 12\text{ V}$		0.80	0.95	V
Output saturation voltage 2	$V_{Osat2(L)}$	$I_O = 1.5\text{ A}$, $V_O(\text{sink})$, $V_{CC1} = 5\text{ V}$, $V_{CC2} = V_{CC3} = 12\text{ V}$		0.40	0.60	V
	$V_{Osat2(H)}$	$I_O = 1.5\text{ A}$, $V_O(\text{source})$, $V_{CC1} = 5\text{ V}$, $V_{CC2} = V_{CC3} = 12\text{ V}$		1.10	1.30	V
Output leakage current	$I_{Oleak(L)}$				100	μA
	$I_{Oleak(H)}$		-100			μA
Diode forward voltage	V_{FH}	Upper side diode, $I_O = 2.0\text{ A}$		1.50	2.00	V
	V_{FL}	Lower side diode, $I_O = 2.0\text{ A}$		1.50	2.00	V
[Hall Amplifier Block]						
Input bias current	I_{HB}		-4	-1		μA
Common-mode input voltage range	V_{ICM}		1.5		$V_{CC} - 1.5$	V
Hall input sensitivity	V_{HIN}		60			mVp-p
Hysteresis	$\Delta V_{IN(HA)}$		23	32	39	mV
Input voltage: low \rightarrow high	V_{SLH}		6	16	25	mV
Input voltage: high \rightarrow low	V_{SLL}		-25	-16	-6	mV
[Thermal Protection Circuit]						
Operating temperature	T-TSD	Design target value (junction temperature) *	150	180	210	$^\circ\text{C}$
Hysteresis	ΔTSD	Design target value (junction temperature) *		40		$^\circ\text{C}$

Note: * These are design target values and are not tested.

Continued on next page.

LB11975

Continued from preceding page.

Parameter	Symbol	Conditions	Ratings			Unit
			min	typ	max	
[PWM Oscillator]						
High-level output voltage	$V_{OH(OSC)}$		3.1	3.3	3.5	V
Low-level output voltage	$V_{OL(OSC)}$		1.4	1.6	1.8	V
Amplitude	$V(OSC)$		1.5	1.7	1.9	V _{p-p}
Oscillator frequency	$f(OSC)$	$C = 2200 \text{ pF}$		23.0		kHz
Charge current	I_{CHG}		-110	-94	-83	μA
Charge resistor value	R_{DCHG}		1.6	2.1	2.6	k Ω
[CTL Amplifier]						
VCTL pin input current	I_{VCTL}	$V_{CTL} = V_{CREF} = 1.65 \text{ V}$	-2			μA
VCREF pin input current	I_{VCREF}	$V_{CTL} = V_{CREF} = 1.65 \text{ V}$	-2			μA
Forward rotation gain	GDF^+	Design target value *	0.20	0.25	0.30	times
Reverse rotation gain	GDF^-	Design target value *	-0.30	-0.25	-0.20	times
Forward rotation limiter voltage	V_{RF1}		0.26	0.29	0.32	V
Reverse rotation limiter voltage	V_{RF2}		0.26	0.29	0.32	V
Startup voltage	V_{CTH}	$V_{CREF} = 1.65 \text{ V}$. Design target value *	1.50		1.80	V
Dead zone	V_{DZ}	$V_{CREF} = 1.65 \text{ V}$. Design target value *	35	80	140	mV
[FG Pin] (speed pulse output)						
Low-level output voltage	V_{FGL}	$I_{FG} = 2 \text{ mA}$			0.4	V
Pull-up resistor value	R_{FG}		7.5	10	12.5	k Ω
[RS Pin]						
Low-level output voltage	V_{RSL}	$I_{RS} = 2 \text{ mA}$			0.4	V
Pull-up resistor value	R_{RS}		7.5	10	12.5	k Ω
[Stop/Start Pin]						
Low-level input voltage	V_{SSL}			0	0.7	V
High-level input voltage	V_{SSH}		2.0		V_{CC1}	V
Low-level input current	I_{SSL}	$V_{SS} = 0 \text{ V}$	-1	0		μA
High-level input current	I_{SSH}	$V_{SS} = 5.0 \text{ V}$		50	200	μA
[Hall Device Power Supply]						
Hall device supply voltage	V_H	$I_H = 5 \text{ mA}$	0.65	0.85	1.05	V
Allowable current	I_H				20	mA

Note: * These are design target values and are not tested.

Truth Table

	Input			Control voltage V_{CTL}	Output Source → Sink	FG output	
	IN1	IN2	IN3			FG1	FG2
1	H	L	H	H	OUT2 → OUT1	L	H
				L	OUT1 → OUT2		
2	H	L	L	H	OUT3 → OUT1	L	L
				L	OUT1 → OUT3		
3	H	H	L	H	OUT3 → OUT2	L	H
				L	OUT2 → OUT3		
4	L	H	L	H	OUT1 → OUT2	H	L
				L	OUT2 → OUT1		
5	L	H	H	H	OUT1 → OUT3	H	H
				L	OUT3 → OUT1		
6	L	L	H	H	OUT2 → OUT3	H	L
				L	OUT3 → OUT2		



Block Diagram

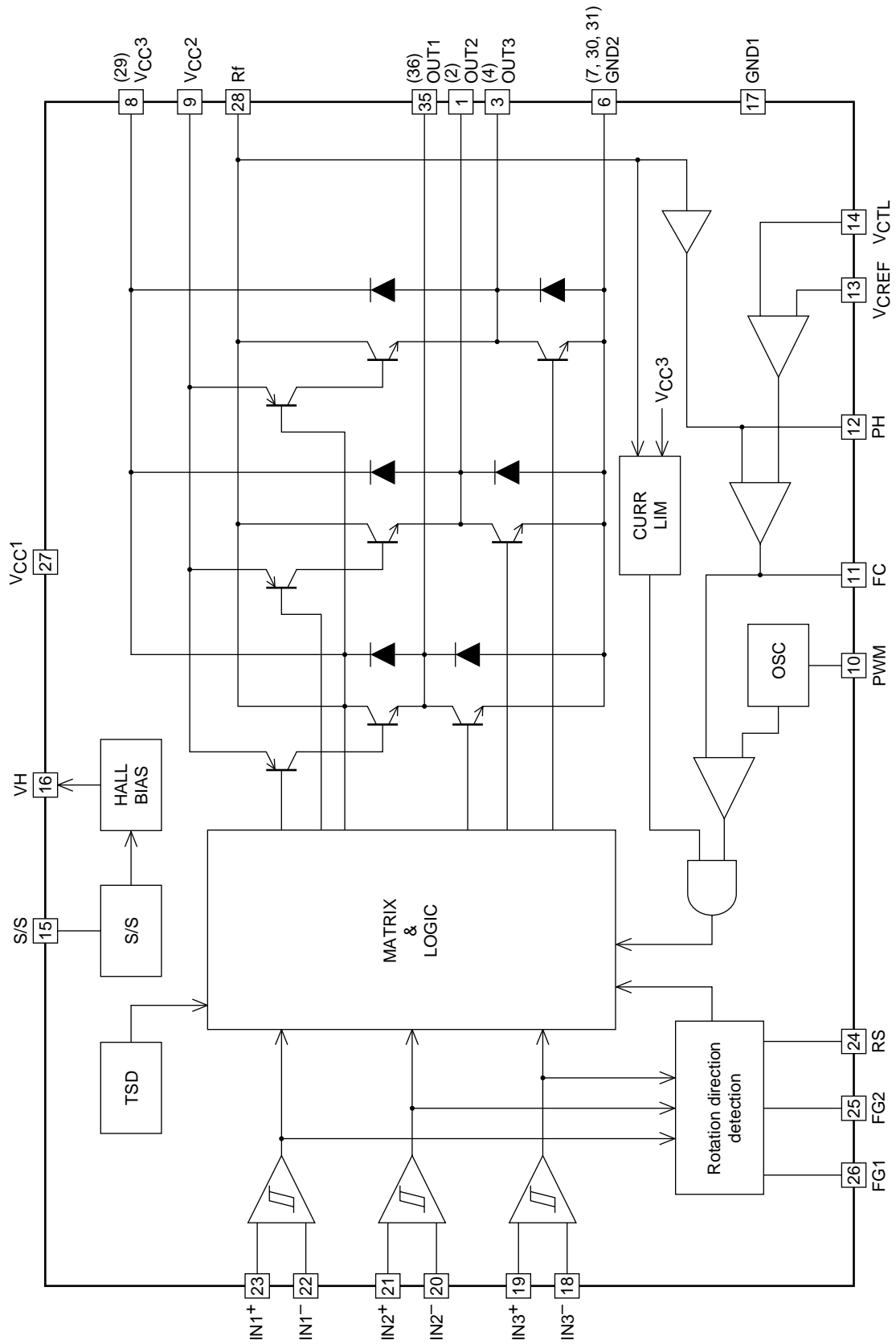

A13185

LB11975

Pin Assignment

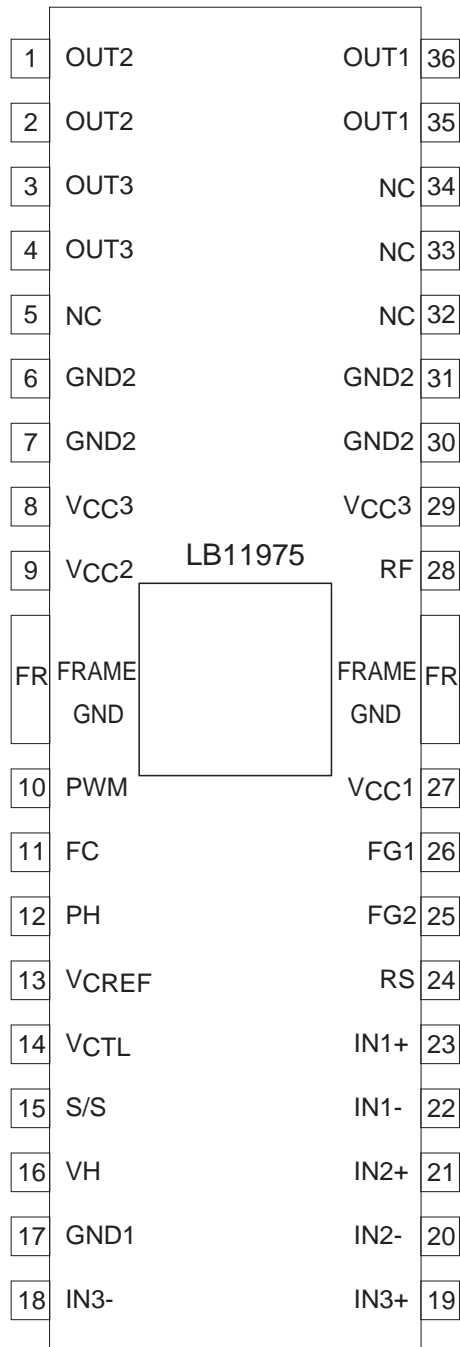

Top view

Sample Application Circuit

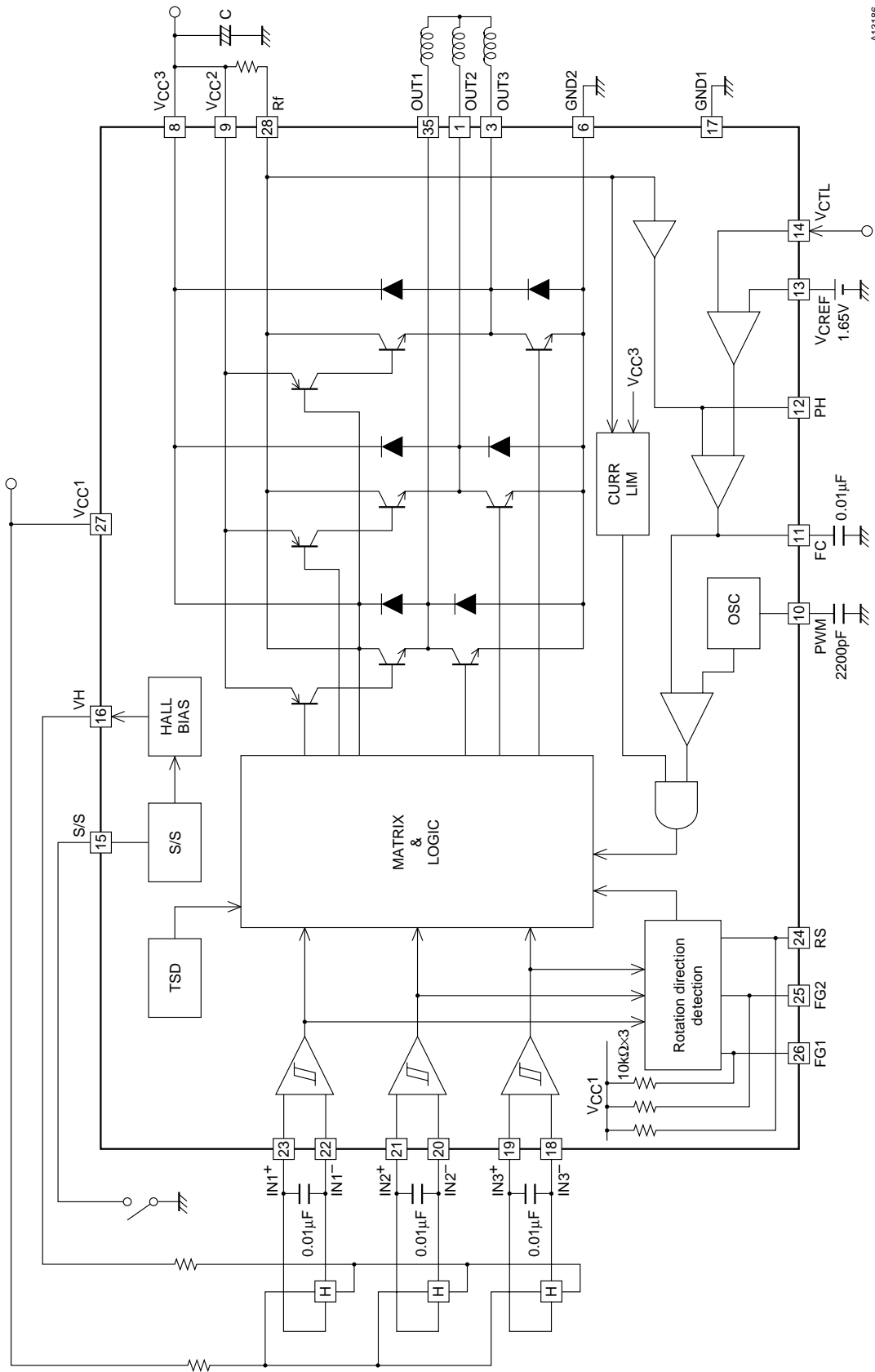

A13186

Pin Functions

Pin No.	Pin	Pin voltage	Function	Equivalent circuit
9	V _{CC2}	4 V to 16 V	Supplies the source side pre-drive voltage.	
8 29	V _{CC3}	4 V to 16 V	Supplies the motor drive voltage.	
27	V _{CC1}	4 V to 16 V	Supply voltage for all circuits other than the output transistors and the source side pre-drive voltage	
24	RS		Reverse rotation detection High-level output: Forward rotation Low-level output: Reverse rotation	
26	FG1		Single Hall device waveform Schmitt comparator synthesized output	
25	FG2		Three Hall device waveform Schmitt comparator synthesized output	
23	IN1 ⁺	1.5 V to V _{CC1} - 1.5 V	U phase Hall device input. Logic high refers to the state where IN1 ⁺ > IN1 ⁻ .	
22	IN1 ⁻			
21	IN2 ⁺		V phase Hall device input. Logic high refers to the state where IN2 ⁺ > IN2 ⁻ .	
20	IN2 ⁻			
19	IN3 ⁺		W phase Hall device input. Logic high refers to the state where IN3 ⁺ > IN3 ⁻ .	
18	IN3 ⁻			
16	VH		Provides the Hall device lower side bias voltage.	
15	S/S	0 V to V _{CC1}	All circuits can be set to the non-operating state by setting this pin to 0.7 V or under, or by setting it to the open state. This pin must be held at 2 V or higher.	
17	GND1		Ground for all circuits except the output	

Continued on next page.

Continued from preceding page.

Pin No.	Pin	Pin voltage	Function	Equivalent circuit
11	FC		Control loop frequency characteristics correction Closed loop oscillation in the current control system can be stopped by connecting a capacitor between this pin and ground.	
10	PWM		PWM oscillator capacitor connection	
13	V _{CREF}	0 V to V _{CC1} – 1.5 V	Control reference voltage input The control start voltage is determined by this voltage.	
14	V _{CTL}	0 V to V _{CC1} – 1.5 V	Speed control voltage input This IC implements a voltage control system in which VC > V _{CREF} means forward rotation and VC < V _{CREF} means slow forward rotation. (This IC includes reverse rotation prevention circuit, so reverse rotation will not occur.)	
3, 4	OUT3		W phase output	
6, 7	GND2		Ground for the output transistors	
30, 31				
1, 2	OUT2		V phase output	
35, 36	OUT1		U phase output	
28	RF		Upper side npn transistor collector (shared by all three phases) Connect a resistor between V _{CC3} and the RF pin for current detection. The fixed current control system and the current limiter operate by detecting this voltage.	
12	PH		Peak hold circuit capacitor connection. Connect a capacitor to this pin to smooth the voltage detected by the resistor RF.	

Torque Command

Figure 1 shows the relationship between the control voltage (V_{CTL}) and the RF voltage.

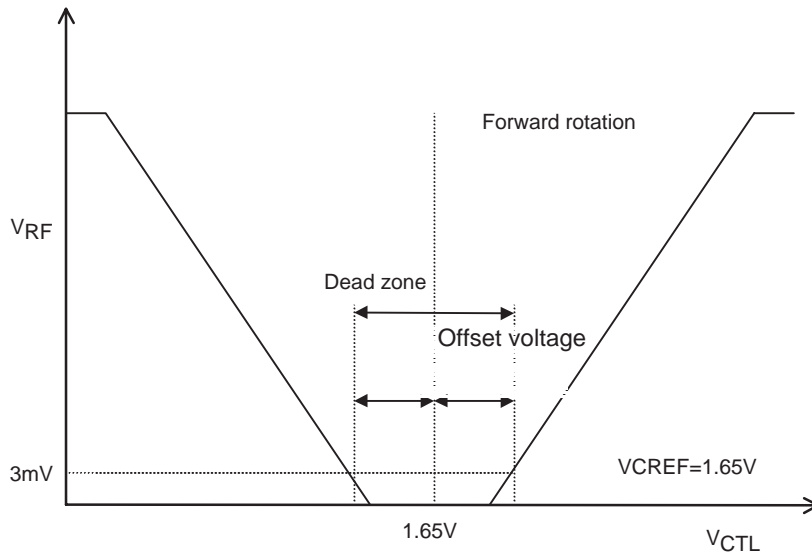

Figure 1

Truth Table

	Operation
$V_{CTL} > V_{CREF}$	Forward rotation
$V_{CREF} > V_{CTL}$	Reverse torque braking *

Note: * Since this IC includes a reverse rotation prevention circuit, although the IC will brake the motor if the motor is rotating and $V_{CTL} < V_{CREF}$, when reverse rotation is detected, the IC will turn the output off, thus stopping motor rotation.

Reverse Rotation Detection Circuit Truth Table

	RS pin
Forward rotation	HIGH
Reverse rotation	LOW

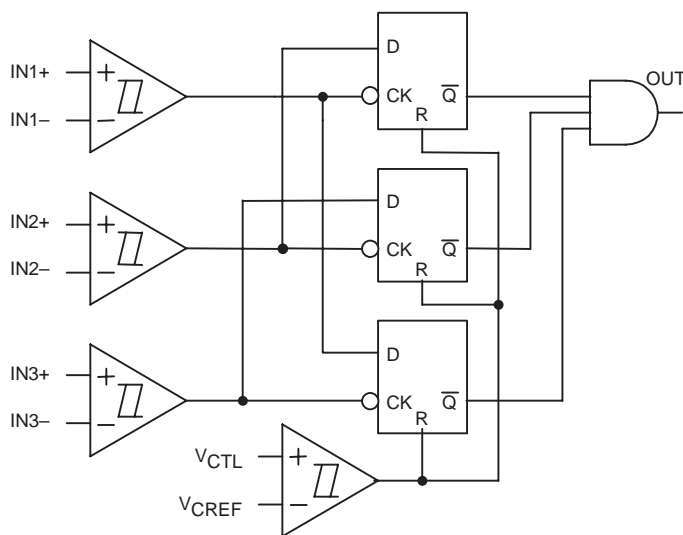

During forward rotation:
The OUT signal is set high to reset DFF.

During reverse rotation:
Reverse rotation is detected when the Hall comparator output falls.
At that point the OUT signal is set to the low level.

Figure 2 Reverse Rotation Detection Circuit Block Diagram

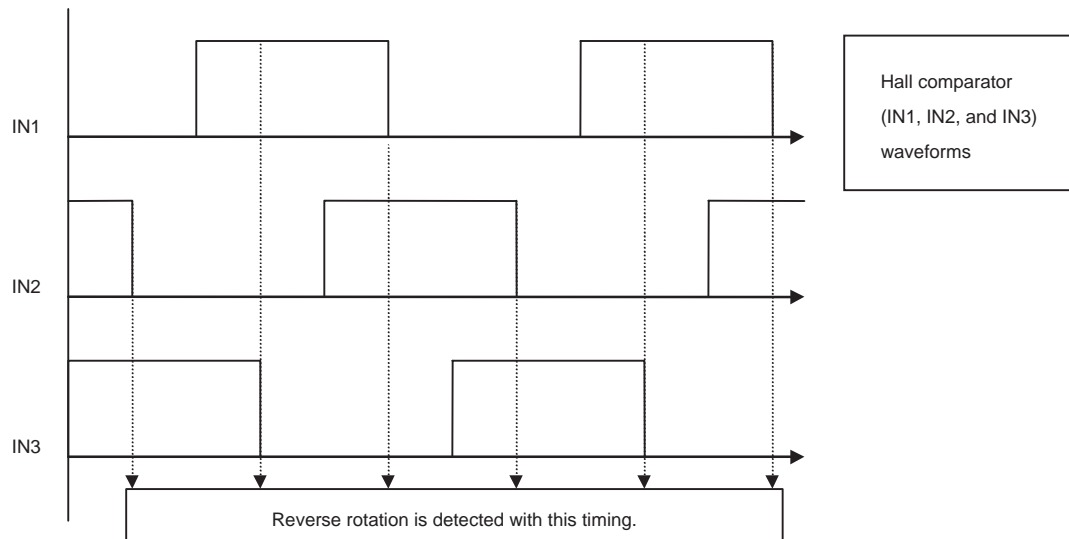

Figure 3 Reverse Rotation Timing Chart

Overview of Reverse Torque Braking

(This circuit uses a direct PWM drive technique and allows the current limiter to operate during reverse torque braking.)

In earlier direct PWM motor drivers, speed control was implemented by applying PWM to only one (either the upper or lower) output transistor. With this type of driver, the regenerative current formed during reverse torque braking operated as a short-circuit braking. As a result problems such as the coil current exceeding the limit value and I_{Omax} being exceeded, would occur. To prevent these problems, the LB11975 switches both the upper and lower side output transistors during reverse torque braking to suppress the generation of overcurrents due to regenerative currents when the PWM is off and allows the optimal design of drive currents.

Supplementary Documentation

Coil current during reverse torque braking

- (1) Earlier ICs, with the lower side transistor was switched and the upper side transistor used for current detection (RF)

During reverse torque braking, when the coil current increases and the limit is reached, the lower side output transistor is turned off. At this time the regenerative current flows through the upper side transistor. The circuit path is as follows:

Coil \rightarrow upper side diode $\rightarrow V_{CC} \rightarrow$ RF \rightarrow upper side transistor \rightarrow coil

During regeneration, the upper side transistor is on and the back EMF that occurs at the upper side transistor's emitter pin has a low potential, and since the upper side transistor is fully on at that point, the circuit functions as short-circuit braking.

Even if the regenerative current results in the RF voltage reaching the limit voltage, since the upper side transistor cannot be turned off, the limit circuit will not operate and a coil current in excess of I_{Omax} may occur.
- (2) Earlier ICs, with the upper side transistor was switched and the upper side transistor used for current detection (RF)

During reverse torque braking, when the coil current increases and the limit is reached, the upper side output transistor is turned off. At this time the regenerative current flows through the lower side transistor. The circuit path is as follows:

Coil \rightarrow lower side transistor \rightarrow ground \rightarrow lower side diode \rightarrow coil

During regeneration, the lower side transistor is on and the back EMF that occurs at the lower side transistor's collector pin has a high potential, and since the lower side transistor is fully on at that point, the circuit functions as short-circuit braking.

Since the regenerative current does not flow through the RF pin, the current limiter circuit does not operate, and a current in excess of I_{Omax} may occur in the lower side transistor.

(3) When both the upper and lower side transistors are switched and current detection (RF) is performed in the upper side transistor

During reverse torque braking, when the coil current increases and the limit is reached, both the upper and lower side transistors are turned off. The motor current circuit path at this point is as follows:

Coil → upper side diode → V_{CC} → power supply line capacitor → ground → lower side diode → coil

When the limiter circuit operates, both the upper and lower side transistors are turned off, so short-circuit breaking does not occur, and coil current attenuation is all that occurs. Thus this technique allows current control at the set (limiter) current to be performed even during reverse torque braking.

Regenerative Current Path

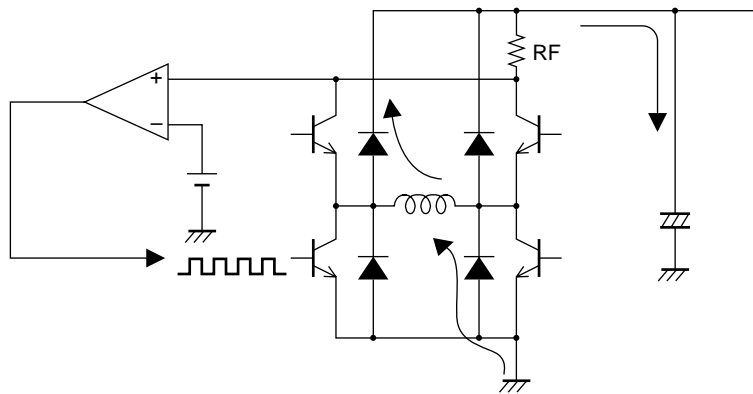

A13187

Drive Mode

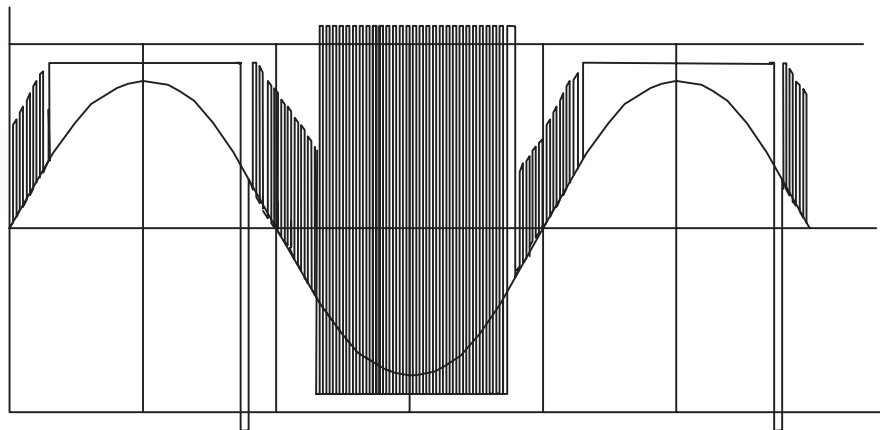

Braking Mode

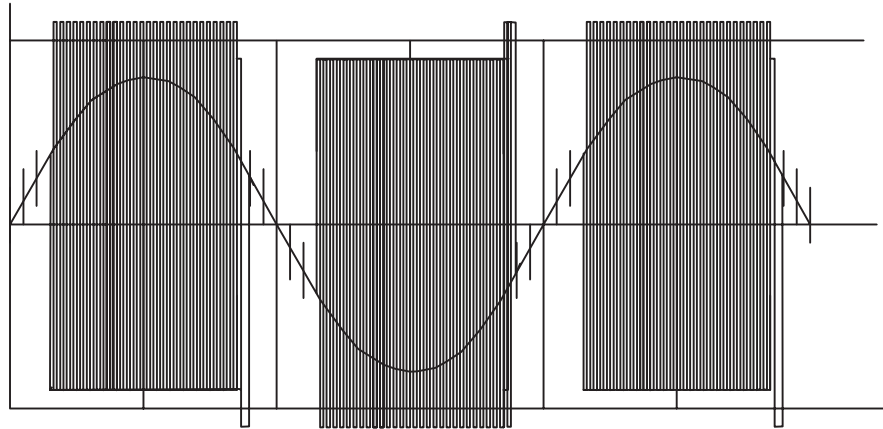

- Specifications of any and all SANYO products described or contained herein stipulate the performance, characteristics, and functions of the described products in the independent state, and are not guarantees of the performance, characteristics, and functions of the described products as mounted in the customer's products or equipment. To verify symptoms and states that cannot be evaluated in an independent device, the customer should always evaluate and test devices mounted in the customer's products or equipment.
- SANYO Electric Co., Ltd. strives to supply high-quality high-reliability products. However, any and all semiconductor products fail with some probability. It is possible that these probabilistic failures could give rise to accidents or events that could endanger human lives, that could give rise to smoke or fire, or that could cause damage to other property. When designing equipment, adopt safety measures so that these kinds of accidents or events cannot occur. Such measures include but are not limited to protective circuits and error prevention circuits for safe design, redundant design, and structural design.
- In the event that any or all SANYO products (including technical data, services) described or contained herein are controlled under any of applicable local export control laws and regulations, such products must not be exported without obtaining the export license from the authorities concerned in accordance with the above law.
- No part of this publication may be reproduced or transmitted in any form or by any means, electronic or mechanical, including photocopying and recording, or any information storage or retrieval system, or otherwise, without the prior written permission of SANYO Electric Co., Ltd.
- Any and all information described or contained herein are subject to change without notice due to product/technology improvement, etc. When designing equipment, refer to the "Delivery Specification" for the SANYO product that you intend to use.
- Information (including circuit diagrams and circuit parameters) herein is for example only; it is not guaranteed for volume production. SANYO believes information herein is accurate and reliable, but no guarantees are made or implied regarding its use or any infringements of intellectual property rights or other rights of third parties.

This catalog provides information as of January, 2001. Specifications and information herein are subject to change without notice.