

3·3/4 DIGIT SINGLE CHIP DIGITAL MULTIMETER LSI**■ GENERAL DESCRIPTION**

The NJU9210C is 3·3/4 digits with 42 segments bargraph single chip digital multimeter LSI.

The AD converter block incorporates two kind of dual-slope AD converter such as high-accuracy and high-speed converter.

The high-accuracy AD converter performs accurate 3·3/4 digits digital display and the high-speed AD converter performs high-speed 42 segments bargraph display.

The input attenuator part of NJU9210C can be simplified because of incorporated resistance for resistance measurement is also applied for the bleeder resistance.

The NJU9210C is suitable for high-performance full-auto-ranging digital multimeters because of many functions controlled by internal CPU, such as data hold, data memory, auto power-off and external relay driving which enables input range selection including current measurement mode.

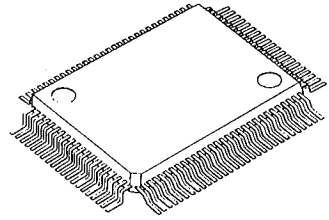
■ PACKAGE OUTLINE**NJU9210CF****5****■ FEATURES**

- 3·3/4 digits display (± 3999)
- 42 Segments Bargraph Display
- High-Accurate AD Converter for Digital Display -- 2 Times / sec
- High-Speed AD Converter for Bargraph Display -- 20 Times / sec
- Full Auto-ranging Measurement
- Rotary or Push type Input Mode selection
- External Relay Driving
- Power-on Initialization
- Auto Power-off Function
- Data Hold Function
- Data Memory Function
- Relative Display Function
- Capacitor Measurement Function
- Reference Voltage On-Chip (External Reference Voltage also available)
- LCD Display
- Piezo Buzzer Direct Driving
- Serial Data Output (BCD Format)
- Low Operating Current
- Low Operating Voltage (Battery Operation)
- Package Outline -- QFP 100
- C-MOS Technology

■ PIN CONFIGURATION

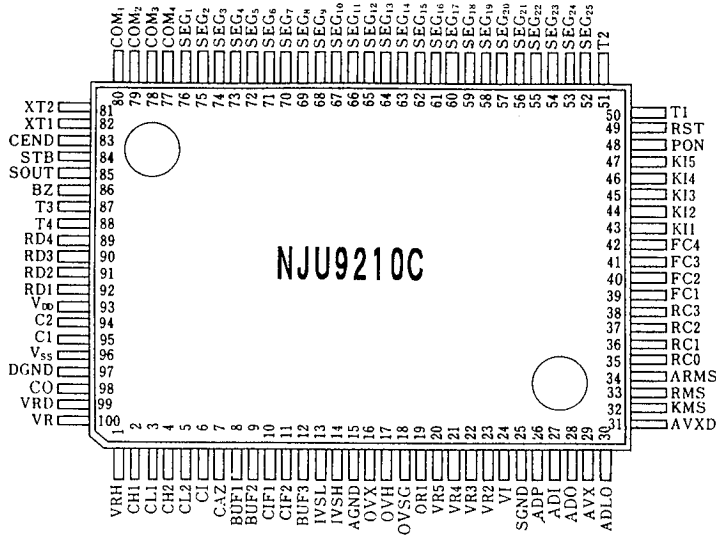

5

■ BLOCK DIAGRAM

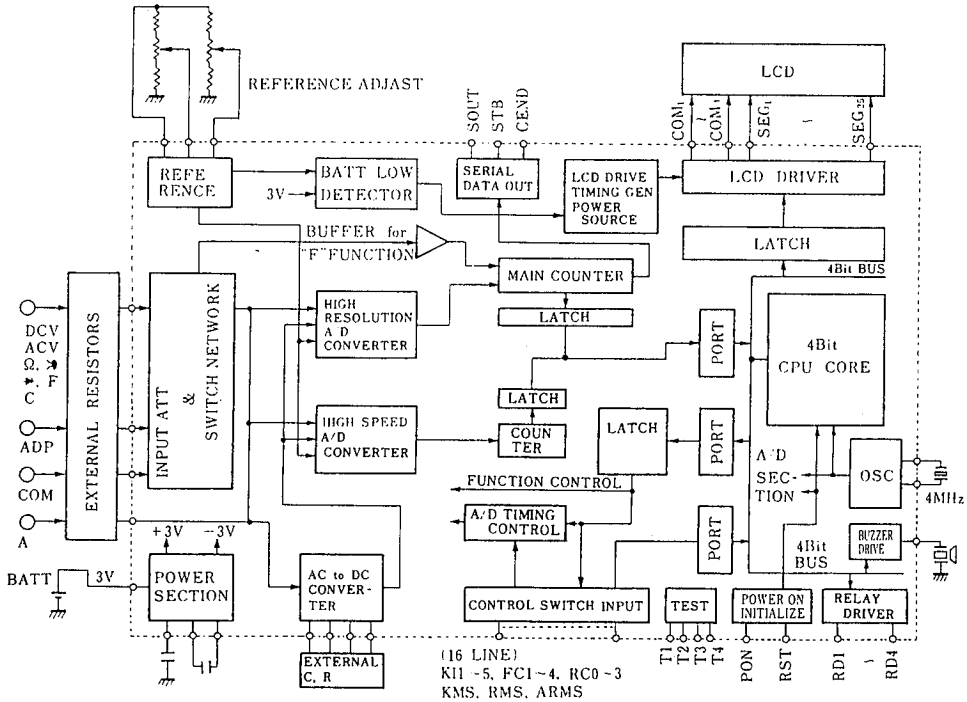

■ TERMINAL DESCRIPTION

NO.	SYMBOL	F U N C T I O N
1 99 100	VRH VRD VR	Reference voltage output terminal Internal reference voltage monitor terminal Reference voltage input terminal VR=+1.0V
2, 3 4, 5	CH1, CL1 CH2, CL2	Reference capacitor1 connecting terminal CH1; connect "+", CL1; connect "-" Reference capacitor2 connecting terminal CH2; connect "+", CL2; connect "-"
6	CI	Integration Capacitor connecting terminal
7	CAZ	Auto-zero capacitor connecting terminal
8, 9 12	BUF1, BUF2 BUF3	Buffer output terminals 1, 2 High-speed integrator buffer output terminal
10, 11	CIF1, CIF2	High-speed integration capacitor connecting terminals
13 14	IVSL IVSH	Low-current measurement sensing terminal High-current measurement sensing terminal
16 17 18	OVX OVH OVSG	Resistance measurement sensing terminal Resistance measurement voltage supply terminal Reference resistance sensing terminal
19	OR1	Reference resistance terminal for 400Ω range
20 21 22 23	VR5 VR4 VR3 VR2	Bleeder Resistance terminal for 4000V range Bleeder Resistance terminal for 400V range Bleeder Resistance terminal for 40V range Bleeder Resistance terminal for 4V range
24	VI	Voltage input terminal
26	ADP	Adaptive input terminal
27 28, 30 29, 31	AD1 ADD, ADLO AVX, AVXD	AC/DC conv. op-amplifier input terminal AD1; "-"input AC/DC conv. op-amplifier output terminals ADD; "+"output ADLO; "-"output AC/DC conv. circuit output terminals AVX; "+"output AVXD; "-"output
32 33 34 35-38 39-42 43-47 48 49	KMS RMS ARMS RC0-RC3 FC1-FC4 K11-K15 PON RST	Key mode Selection terminal Ranging control mode selection terminal Current range control mode selection terminal Range selection terminals Function selection terminals Adaptive function control terminals Auto power-off reset terminal System reset terminal
50, 51, 87, 88	T1, T2 T3, T4	Test terminals
52-76 77-80	SEG ₂₅ -SEG ₁ COM ₄ -COM ₁	LCD display segment terminals LCD display common terminals
81, 82	XT2, XT1	Crystal oscillation Inverters XT2; output XT1; input
83 84 85	GEND STB SOUT	Serial data transmission ending signal terminal Serial data strobe signal terminal Serial data output terminal
86	BZ	Piezo buzzer driving terminal
89-92	RD4-RD1	External Relay driving terminals
93 96 15 97 25	V _{DD} V _{SS} AGND DGND SGND	Power supply terminal V _{DD} = +3V Negative voltage output terminal V _{SS} = -2.8V (typ) Analog GND AGND= 0V Digital GND DGND= 0V GND Sensing terminal
94, 95	C2, C1	Charge pump capacitor connecting terminals C2;connect "-", C1;connect "+"
98	C0	High accuracy integrator comparator output terminal

FUNCTIONAL DESCRIPTION

The NJU9210C is 3·3/4 digits with 42 segments bargraph single chip digital multimeter LSI. It adopts high-accuracy dual-slope conversion method for 3·3/4 digits display and high-speed dual-slope conversion method for bargraph display.

The NJU9210C incorporates the 4-bit CPU and performs following functions:

- ① Auto power-off after 30 minutes of final operation.
- ② Data hold (included MIN & MAX).
- ③ Measurement data memory
- ④ Relative display of measurement result.
- ⑤ Serial data output by BCD format.
- ⑥ Power-on-initialization
- ⑦ Buzzer output when the key input(range, measurement function), over range, continuity test, power-on and auto power-off.
- ⑧ Low Battery detection
- ⑨ Full-auto-ranging by using external relay.

The NJU9210C can measure the voltage(AC,DC), current(AC,DC), resistance, frequency, diode, continuity, capacitance and adaptive(temperature/hfe) values. As the reference resistance is used both of resistance measurement and bleeder resistance for the input attenuator part. Therefore, external high-accuracy resistor can be reduced.

The high accuracy measurement is performed by using internal voltage reference or external voltage reference.

The the reference voltage, it is also available supplied from outside.

The sampling rate is

- 2 times per second for digital display
- 20 times per second for bargraph display
- 1 times per second for capacitance measurement.

The contents of LCD display is

- 28 segments for 3·3/4 digits digital display
- 42 segments for bargraph display
- 28 segments for decimal point, unit and symbol display etc.
- 2 segments for option.
- 100 segments in total.

The lock and push type of switch can be used to select the mode and either one of auto or manual mode is selected by this selection switch.

The result of measurement is displayed on the LCD display.

The NJU9210C operated by 3V. Therefore, only two battery (1.5V x 2) is enough for the power supply.

(1) Measurement Function List

Measurement Mode	Range	Auto / Manual
DC/AC Voltage	400mV~4000V	Auto: 5-range / Manual: 5-range *1
DC/AC Current	4mA ~ 4000mA	Auto: 2-range / Manual: 4-range
DC/AC Current	40A	Fixed
Resistance (Ω)	400Ω~40MΩ	Auto: 6-range / Manual: 6-range
Frequency (f)	100Hz~1000kHz	Auto: 5-range / Manual *2
Capacitance(C)	4nF ~ 40μF	Auto: 5-range / Manual: 5-range
A D P		Fixed *3
Diode →		Fixed
Continuity ≫		Fixed

* 1) ACV auto range is only 4 range and 400mV can be selected in only manual range.

* 2) The frequency range is always set to auto range, however the input attenuation level must be set by manual.

* 3) ADP can be applied for °C, hfe and other measurement.

(2) Input Attenuator

The input attenuator and peripheral circuit of NJU9210C are shown below:

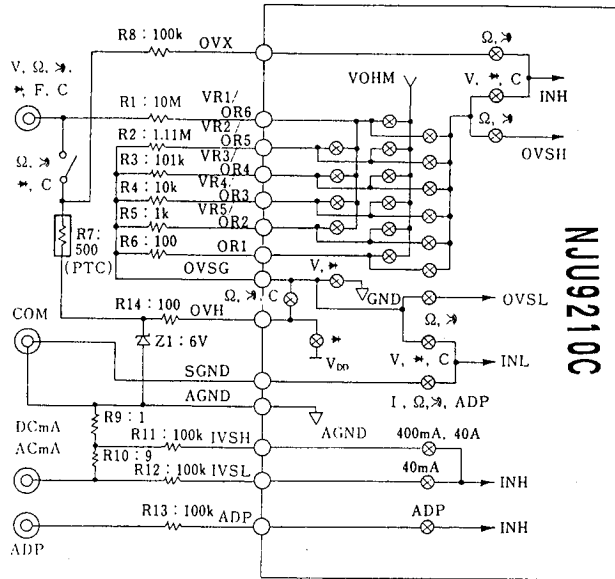

Operation for each mode are :

- ① Voltage (DC/AC·V) measurements
 The bleded voltages output from each resistance R1~R5 shown in right table are supplied to A/D converter.

Range	Division Rate
VR1 (400mV)	1
VR2 (4 V)	$R2/(R1+R2)$
VR3 (40V)	$R3/(R1+R3)$
VR4 (400V)	$R4/(R1+R4)$
VR5 (4000V)	$R5/(R1+R5)$

- ② Resistance value measurement
 The reference resistance is set by input attenuator of resistor R1~R6 shown in right table and performs A/D conversion. The output voltage on the measurement terminal is about 0.4V.

Range	Refer. Resistance Value
VR1 (400Ω)	R6
VR2 (4kΩ)	R5
VR3 (40kΩ)	$R4 \cdot R1 / (R1 + R4)$
VR4 (400kΩ)	$R3 \cdot R1 / (R1 + R3)$
VR5 (4000kΩ)	$R2 \cdot R1 / (R1 + R2)$
VR6 (40MΩ)	R1

- ③ Continuity Test \rightarrow
 The input attenuator is fixed to 400Ω range of resistance measurement mode. And the output voltage on the measurement terminal is about 0.4V.
- ④ Diode Check \rightarrow
 The input attenuator is fixed to DC 4V range. The output voltage on the OVH terminal is about 3V. And it is supplied to the measurement terminal through the SW1(external switch or relay).

- ⑤ Current (DC/AC · mA) measurements
40mA and 400mA ranges are performed in auto ranging by changing the voltage sensing terminals. But other ranges are required reference resistance changing by external switch. Furthermore, the auto ranging from 4mA to 4000mA is also available to by using external latching relay.
- ⑥ Current (DC/AC · A) measurements
It is fixed to 40A range.
- ⑦ Frequency (f) measurement
The input attenuator must be set either one of 10mA, 100mV or 1V range by manual. The attenuator output is supplied to counter through the buffer. The frequency range is always set to auto range from 100kHz to 1000kHz.
- ⑧ Adaptive (ADP) measurement
The voltage on ADP terminal and SGND terminal is supplied to A/D converter directly. Both of ADP terminal(+) and SGND terminal(-) are high-impedance in DC400mV range. Therefore, it can be used as differential input.
- ⑨ Capacitance (C) measurement
Capacitance (C) measurement mode is using one of T-F conversion method.

(3) Switch Input Mode

The lock or push type input switch can be used for function selection. One of each type is selected by the KMS terminal.

In case of the lock type switch is selected, both of auto and manual ranges are available by the RMS terminal setting. And the push type switch is selected, auto ranging is always selected regardless the RMS terminal setting.

When the lock type switch is selected and terminal RMS is GND level, all ranges must be selected by switch, but if the RMS terminal is V_{DD} level, auto range, manual range selection and range set is performed by one of push type switch.

KMS Terminal	RMS Terminal	Switch	Range
H	H	Lock type	Full Auto
H	L		Manual
L	X	Push type	Full Auto

X) Don't Care

(a) Lock Type Switch

(a-1) Measurement Function Selection (KMS = "H")

If the lock type is selected, measurement function is set by terminal FC1 to FC4.
 Except the following settings, all others becomes DC·V measurement mode.

Measurement Mode	FC1	FC2	FC3	FC4
D C V	H	H	H	H
A C V	L	H	H	H
D C mA	H	L	H	H
A C mA	L	L	H	H
Resistance (Ω)	H	H	L	H
Continuity (\rightarrow)	L	H	L	H
Diode (\rightarrow)	H	L	L	H
Capacitance(C)	L	L	L	H
D C A	H	H	H	L
A C A	L	H	H	L
Frequency (f)	H	L	H	L
A D P	L	L	H	L

(a-2) Range Setting (When select the lock type and auto ranging KMS = "H", RMS = "H")

The range control mentioned in below table is available by RCD terminal switch operation which is input the "L" level (GND) when pressed.

When press the switch one time, the range is changed from auto range to manual range and its range is held.

Afterward, the range is changed alternatively by each press the switch.

The range is changed to auto range from any kinds of range when the switch is pressed over one second.

Measurement Mode	1push(>1sec) \leftarrow Range up Auto \rightarrow Manual \rightarrow Manual \swarrow/\searrow 1push (<1sec) 1push (<1sec) 1push (<1sec)			Ranging Control	Default Range	
D C V	RNG1~RNG5	→HOLD	RNGi→RNGi+1	(RNG5→RNG1)	400mV~4000V	400mV
A C V	RNG2~RNG5			(RNG5→RNG1)	400mV~4000V	4 V
D C mA	RNG2~RNG3			(RNG3→RNG2)	40mA~400mA	40mA
A C mA	RNG2~RNG3			(RNG3→RNG2)	40mA~400mA	40mA
Resistance (Ω)	RNG1~RNG6			(RNG6→RNG1)	400 Ω ~40M Ω	400 Ω
Continuity (\rightarrow)					400 Ω	
Diode (\rightarrow)					4 V	
A D P	FIXED				400mV	
D C A					40A	
A C A					40A	
Frequency (f)	RNG1~RNG5		-		100Hz~999.9kHz	100Hz
Freq.(Sensitive)	-			(RNG3→RNG1)	10mV~1V	10mV
Capacitance(C)	RNG1~RNG5	→HOLD	RNGi→RNGi+1	(RNG5→RNG1)	4nF~40 μ F	4 nF

(Note) In frequency measurement mode, the range is always set to auto but the sensitivity must be selected by manual.

The Continuity, Diode, ADP, DC A and AC A measurement are always fixed the range.

When power is turned-on, default range is selected.

In the ADP measurement, 3 kinds of unit can be displayed setting by terminals RC1~RC3.

The RNG1 ~ RNG6 of above range control table are correspond to each range of each mode shown below:

Range	DCV	ACV	CDmA	ACmA	Ω	f	Sensitivity	C
RNG1	⊙400mV	400mV	-	-	⊙400 Ω	⊙100Hz	⊙ 10mV	⊙ 4 nF
RNG2	4V	⊙ 4V	⊙ 40mA	⊙ 40mA	4 k Ω	1000Hz	100mV	40nF
RNG3	40V	40V	400mA	400mA	40k Ω	10kHz	1 V	400nF
RNG4	400V	400V	-	-	400k Ω	100kHz	-	4 μ F
RNG5	4000V	4000V	-	-	4000k Ω	1000kHz	-	40 μ F
RNG6	-	-	-	-	40M Ω	-	-	-

(Note) The "⊙" mark is mentioned default range.

(a-3) Range Setting (When select the lock type switch and manual range. KMS="H", RMS="L")
The following range can be selected by terminals RC1, RC2 and RC3.

RC1	RC2	RC3	DC, ACV	DC, ACmA	Ω	Sensitivity	C
H	H	H	400mV	4 mA	400 Ω	10mV	4 nF
L	H	H	4 V	40mA	4 k Ω	100mV	40nF
H	L	H	40V	400mA	40k Ω	1 V	400nF
L	L	H	400V	4000mA	400k Ω	10mV	4 μ F
H	H	L	4000V	4 mA	4000k Ω	10mV	40 μ F
L	H	L	400mV	4 mA	40M Ω	10mV	4 nF
H	L	L	400mV	4 mA	400 Ω	10mV	4 nF
L	L	L	400mV	4 mA	400 Ω	10mV	4 nF

(Note) In frequency measurement mode, the range is always set to auto.

The Continuity, Diode, ADP, DC A and AC A measurements are always fixed the range.

(b) Push Type Switch

(b-1) Function Measurement Selection (KMS="L", RMS="X")

Terminals FC1~FC4 and K12~K15 are set the mode mentioned in below matrix table:

		Control Terminals			
		K12	K13	K14	K15
Selection Terminals	FC4	V	mA	A	RANGE
	FC3	DC, AC			Ω
	FC2	f	ADP	REL	C
	FC1	HOLD	MIN/MAX	MEM	READ

All switches except the power switch are used non-locked push type switch.

The range is set to full auto and the function of RANGE key is same as RCD terminal input.

When the power is turned on, the mode is set to the DC-V, but after release the auto-power off back to the mode before auto-power-off.

The functions of Hold, MIN/MAX, MEM, READ and REL are same as K11~K15 input in lock type switch which is explained in attached functions.

5

Example of the Switch Circuit

If some of switches are pressed at the same time, the input order is as follows:

Input Terminal : FC4→FC3→FC2→FC1

Scanning Terminal : K15→K14→K13→K12

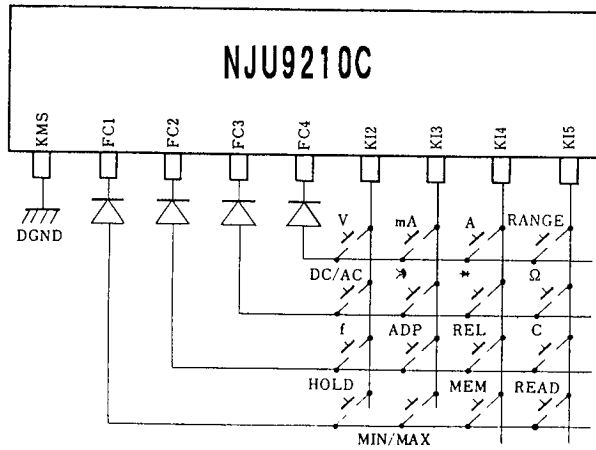

Example of the Latching Relay Driver Circuit

When select the push type switch, and ARMS="H".

Only 40mA and 400mA are auto range and the RD1~RD4 are normally "H".

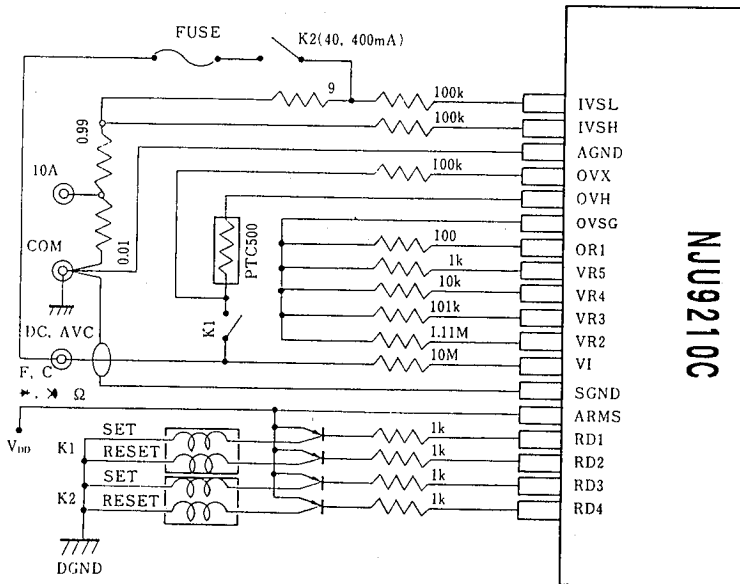

K1 is ON during the $\rightarrow, \rightarrow, \Omega, f, c$ function are in operation.

K2 is ON during the DC, ACmA function are in operation.

(b-2) Auto Range Setting of DC, AC·mA Measurement mode

The DC and AC·mA measurements mode are always set to 40mA or 400mA in auto range.

When the ARMS terminal connect to the GND level, about 100ms pulse width signal is output from the RD1~RD4 for the latching relay operation. Therefore, full auto-range operation from 4mA to 4000mA is available.

Function · Range	Relay	RD1	RD2	RD3	RD4
Ω , \rightarrow , \rightarrow 4 mA 40mA Set 400mA 4000mA	K1		\neg		
	K2			\neg	
	K3		\neg	\neg	
	K4				\neg
	K5		\neg		\neg
Ω , \rightarrow , \rightarrow 4 mA 40mA Reset 400mA 4000mA	K1	\neg	\neg		
	K2	\neg		\neg	
	K3	\neg	\neg	\neg	
	K4	\neg			\neg
	K5	\neg	\neg		\neg

5
Example of the Latching Relay Driver Circuit

Select the push type, ARMS terminal is "L" and auto ranging from 4mA to 4000mA example. The output terminal RD1~RD4 are normal "L" (Active "H").

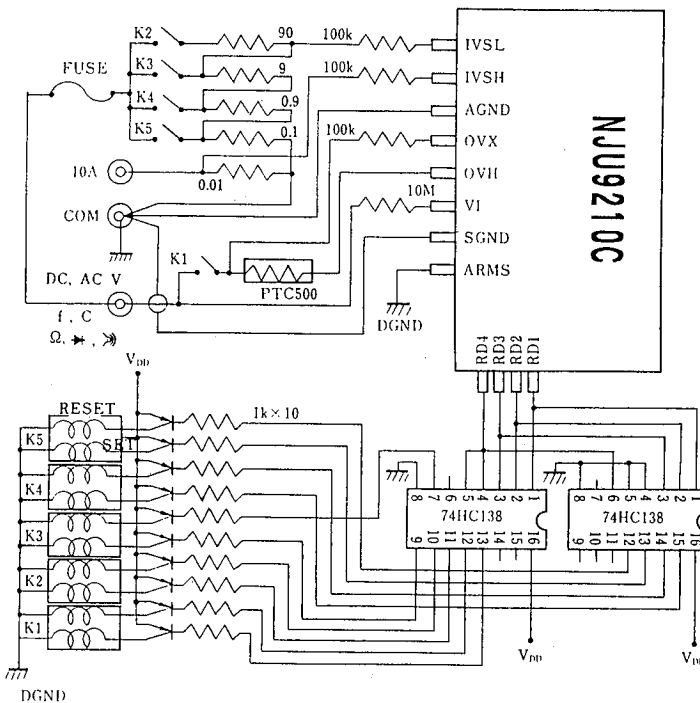

(b-3) The Input Sensitivity Set for Frequency Measurement

The input sensitivity of the frequency measurement is always set by manual.

The default input sensitivity level in auto range is 10mV which is set automatically when power turns on or frequency measurement mode selection. Afterward, the input sensitivity is changed 10mA→100mA→1V→10mA by press the range switch.

Furthermore, the input sensitivity is displayed during 0.5ms after range switch operation.

(4) Attached Functions

Each attached function selected lock type switch for K11~K15 input are as follows:

(4-1) Data Hold: HOLD

The hold and release for all display data is performed alternatively by K11 terminal input.

However, the A/D conversion is operating even though in Hold status, therefore, the buzzer sound is come out when occur the over range or continuity mode. And the range is also changed if it is in auto range.

(4-2) Relative Display: REL

The relative display mode is selected when the switch connect to K12 terminal is pressed. In this mode, the differential value of present and just before value is displayed.

In case of the auto-range, the range is held just before range. The differential value is displayed based on present value when the switch connecting K12 is pressed. However, the bargraph is displayed absolute value, not relative value. And the over-range also occur against the absolute value.

When the K12 input is kept over one second, the relative mode is released.

(4-3) Min/Max Hold: MIN/MAX

When the switch connected terminal K13 is pressed, the mode is changed as follows:

In case of in the auto-range, the mode is held to just before range.

MIN Value Hold→MAX Value Hold→HOLD Release

(4-4) Data Memory: MEM

When the switch connected to terminal K14 is pressed, all of display data is stored in the memory. The stored data can be read out and display on the LCD by pressing the READ key which is connected to K15 terminal, then becomes the hold mode.

During the stored data in the memory display, the MEM mark is blinking. And the hold mode is released by pressing the HOLD switch.

(4-5) Buzzer Output

2kHz buzzer sound is output in following cases:

- ① When operate the key.
- ② When occur the over-range. Except the measurement mode of Resistor(Ω), Frequency(f), Continuity(\Rightarrow) and Diode(\rightarrow).
- ③ When auto-power-off.
- ④ When the continuity measurement result is less than 40 Ω .
- ⑤ When the relative mode is released.
- ⑥ When the mode id changed from manual to auto range by operating the switch connected to the terminal RCO. Please refer the timing chart for the timing.

(4-6) Low-Battery Detector:

If the supply voltage is less than $2.4 \pm 0.2V$, the BATT mark is blinked.

(4-7) Auto-Power-Off

If the switch operated no more than 30 minutes, the power is shut down automatically (Auto-power-off) after one second buzzer sound output. When the auto-power-off mode, all display is disappeared but the data stored in the memory is kept.

This mode is released by pressing the switch connecting to the PON terminal or turn off and on of the power switch.

The auto-power-off function is disregarded, when turn on the power switch pressing the switch connecting to the terminal PON.

(4-8) Setting the Mode at Power On, Function and Range Changing

The following table shows the attached function setting at power on, function and range Changing :

Functions	Power On	Function Changing	Range Changing
Range (Auto Range)	Default range	Default range	-
Range Hold	Reset	Reset	Hold
Data Hold			Reset
Relative Measure.			
MIN/MAX Hold			
Data Memory	All "0" display	Hold	Hold
Auto Power Off	Auto off	Auto off	Auto off

5
(4-9) Display of ADP Setting

When ADP measurement, the following display setting by RC1~RC3 terminal is available.

RC1	RC2	RC3	Mark Display	Decimal Point	Application Example
H	H	H	Non	Non	(hfe measurement)
L	H	H	ADP1	P1	°C (temp. measurement)
H	L	H	ADP2	P3	4,000nF 40.00nF 400.0nF (capacitance measurement)
L	L	H		P2	
H	H	L		P1	
L	H	L	ADP3	P3	4.000 μF 40.00 μF 400.0 μF measurement)
H	L	L		P2	
L	L	L		P1	

(Note) Please refer to the display layout.

(5) Serial Data Output

(5-1) The structure of the serial data

The serial data is output from SOUT terminal on each A/D conversion cycle. The data stream is consisted of 9 x 4bits (36 bit in total) structure contents of the display data. And the start bit and end bit are added in front and back end of the data stream.

1bit	4bits	4bits	4bits	4bits	4bits	4bits	4bits	4bits	4bits	1bit
start	status	digit0	digit1	digit2	digit3	function	range	option 1	option 2	stop

status: Status data of A/D converter

MSB	4 bits				LSB
±	BATT	0			OVER

± : "1" is for the negative(-).

BATT : "1" is for the battery voltage is less than $2.4V \pm 0.2V$.

OVER : "1" is for the over-range input.

digit 0~3 : Display Data

digit	display data
0000	0
0001	1
0010	2
0011	3
0100	4
0101	5
0110	6
0111	7
1000	8
1001	9
1010	Blanking
1011	- 4)
1100	-

function : measurement mode data

function	measurement mode
0000	DC V
0001	AC V
0010	DC mA
0011	AC mA
0100	Ω
0101	\rightarrow
0110	\rightarrow
0111	ADP
1000	DC A
1001	AC A
1010	f
1011	-
1100	C

(Note) 4. No correspond to terminals FC1~FC4 of measurement setting.

5. "-" is represented no output

range : measurement range data

range	DC V, AC V	DC mA, AC mA	Ω	f	C
0000	400mV	4 mA	400 Ω	10kHz	4 nF
0001	4 V	40mA	4 k Ω	100kHz	40nF
0010	40V	400mA	40k Ω	1000kHz	400nF
0011	400V	4000mA	400k Ω	-	4 μ F
0100	4000V	-	4000k Ω	-	40 μ F
0101	-	-	40M Ω	100Hz	-
0110	-	-	-	1000Hz	-
0111	-	-	-	-	-

(Note) The range code is:

Continuity test -- "0000"

Diode test -- "0001"

DC A, AC A measurement are unfixed.

option 1 : additional functions display data

MSB	4 bits				LSB
MAX	MIN	REL			HOLD

option 2 : additional functions display data

MSB	4 bits				LSB
MEM	AUTO	MAN			APOF

(Note) "1" is for every efficiency attached functions.

APOF is alarm data for auto power off. It becomes "1" just before the auto-power-off

(5-2) Serial Data Output Timing

The data is output from SOUT terminal synchronized by rising edge of STB signal.

The effective data is output by LSB first ordered start, status, -----, stop from the fourth clock signal. After stop bit output, 4 to 5 STB signal also output. When the serial data output, about 1 second of CEND signal is output every time.

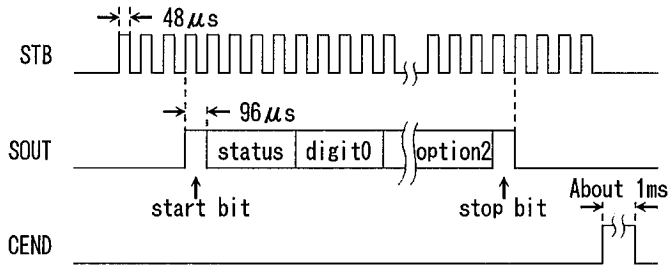

5

(6) Reference Voltage Adjustment

The NJU9210C incorporated the reference voltage, which is adjusted by external fixed resistance and variable resistance.

- (a) Select the capacitance measurement function first. In order to adjust the voltage to 1.000V between DCV/ACV and COM terminals during integrating period by adjusting the variable resistance. In this time, variable resistance adjustment during the integrating period or connect the reference capacitance then adjust the read out.
- (b) Second, select the DC V or resistance measurement mode and connect the reference voltage or reference resistance. Then adjust the measurement result correctly by adjust the variable resistance side of VRD terminal.
- (c) Last, select the AC V measurement mode add connect the reference AC voltage. Then adjust the read out to the reference AC V by adjusting the variable resistance of AC/DC conversion part.

(Note) In order to perform above adjustment methods, following conditions must be met.

- ① Less than $\pm 0.1\%$ accuracy reference resistance ($100\Omega \sim 1.11M\Omega$, $10M\Omega$) should be use.
- ② Low dielectric absorption integrating capacitor and auto-zero capacitor should be use.
- ③ Please note that the 400Ω range displays sometimes read out less than actual resistance value due to board wiring resistance and contacting resistance of socket.

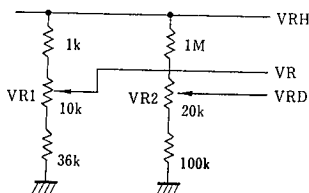

(7) Example of Display Layout
 (7-1) Connection of Common Line

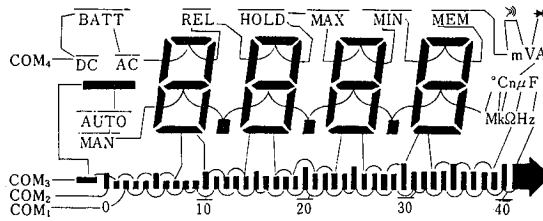

(7-2) Connection of Segment Line

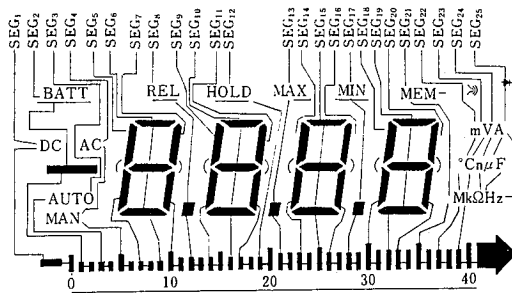

(7-3) Segment Assignment

	SEG ₁	SEG ₂	SEG ₃	SEG ₄	SEG ₅	SEG ₆	SEG ₇	SEG ₈	SEG ₉	SEG ₁₀
COM ₁	BP _N	BP ₂	BP ₄	BP ₆	BP ₈	BP ₉	BP ₁₁	BP ₁₃	BP ₁₅	BP ₁₆
COM ₂	BP ₀	BP ₁	BP ₃	BP ₅	BP ₇	d ₃	BP ₁₀	BP ₁₂	BP ₁₄	d ₂
COM ₃	BP ₋	-	AUTO	MAN	e ₃	g ₃	c ₃	p ₃	e ₂	g ₂
COM ₄	DC	BATT	/	AC	f ₃	a ₃	b ₃	REL	f ₂	a ₂

	SEG ₁₁	SEG ₁₂	SEG ₁₃	SEG ₁₄	SEG ₁₅	SEG ₁₆	SEG ₁₇	SEG ₁₈	SEG ₁₉	SEG ₂₀
COM ₁	BP ₁₈	BP ₂₀	BP ₂₂	BP ₂₄	BP ₂₅	BP ₂₇	BP ₂₉	BP ₃₁	BP ₃₂	BP ₃₄
COM ₂	BP ₁₇	BP ₁₉	BP ₂₁	BP ₂₃	d ₁	BP ₂₆	BP ₂₈	BP ₃₀	d ₀	BP ₃₃
COM ₃	c ₂	/	p ₂	e ₁	g ₁	c ₁	p ₁	e ₀	g ₀	c ₀
COM ₄	b ₂	HOLD	MAX	f ₁	a ₁	b ₁	MIN	f ₀	a ₀	b ₀

	SEG ₂₁	SEG ₂₂	SEG ₂₃	SEG ₂₄	SEG ₂₅
COM ₁	BP ₃₆	BP ₃₈	BP ₄₀	F	Hz
COM ₂	BP ₃₅	BP ₃₇	BP ₃₉	Ω	μ
COM ₃	M	°C	k	n	A
COM ₄	MEM	m	↻	V	→

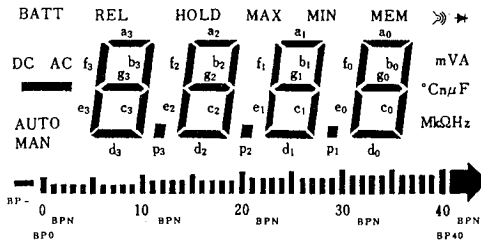

(7-4) Explanation of Display Mark

- ① BATT : Low-battery Detecting mark. This mark blinks when the battery voltage is less than $2.4V \pm 0.2V$.
- ② DC : Displays in the DC voltage, DC current measurements mode.
- ③ AC : Displays in the AC voltage, AC current measurements mode.
- ④ - : Displays in the DC voltage, DC current and ADP measurements negative input. This Mark does not display in the AC voltage, AC current, resistance(Ω), frequency(f), continuity(\Rightarrow), diode(\blacktriangleright) and capacitance(C) measurement mode. However, it is displayed in REL measurement mode.
- ⑤ AUTO : Displays in the auto range measurement mode.
- ⑥ MAN : Displays in the manual range measurement mode.
- ⑦ REL : Displays in the relative function measurement mode.
- ⑧ HOLD : Data Hold. This mark is displayed when the memory data is read out by READ key operation.
- ⑨ MAX : Displays in the MAX value is held.
- ⑩ MIN : Displays in the MIN value is held.
- ⑪ MEM : Displays when the data is stored in memory and blinks when read out.
- ⑫ \Rightarrow : Displays in the continuity test measurement mode.
- ⑬ \blacktriangleright : Displays in the diode test measurement mode.
- ⑭ mV : Displays in the DCmV and ACmV range using.
- ⑮ mA : Displays in the DCmA and DCmA range using.
- ⑯ $^{\circ}C$: ADP1 mark displays in the ADP measurement mode.
- ⑰ nF : ADP2 mark displays in the capacitance measurements(4nF, 40nF and 400nF ranges) mode.
- ⑱ μF : ADP3 mark displays in the capacitance measurements(4 μF and 40 μF ranges) mode.
- ⑲ Ω : Displays in the resistor measurement (400 Ω range) mode.
k Ω : Displays in the resistor measurement (k Ω range) mode.
M Ω : Displays in the resistor measurement (M Ω range) mode.
- ⑳ kHz : Displays in the frequency measurement mode.

(7-5) Bargraph Display

The bargraph is displayed 10 times speed against the digital display. However, it is not displayed in the frequency and capacitance measurement modes.

- ① BP- : Displays in case of the input signal is negative.
- ② BP0 : Displays in case of the digital display is more than "0020".
- ③ BP1~40 : BP1 is displayed in case of the digital display is more than "0100", afterward the BP2 is displayed in case of the digital display is "0200" and BP1~39 is displayed in case of the digital display is "3900". If the over-range is occurred all of BP0~40 are displayed.
- ④ The figure of "0", "10", "20", "30", "40" under the bargraph is displayed by the power on. However, it is not displayed in the frequency and capacitance measurement modes.

(7-6) Over-Range Display

When the over range is occurred, the internal counter count-up to "4000" and the display becomes "4000" with most significant digit blinks. In case of the over-range in the frequency range, the display becomes "0000" with most significant digit blinks.

(7-7) Polarity Display

The mark (-) is not displayed in case of the display value is "0" and AC Voltage, AC Current, Resistor(Ω), Frequency(f), Diode(\blacktriangleright), Continuity (\gg) and Capacitance measurement mode.

However, it displays in any kind of measurement mode of the Relative measurement mode.

■ ABSOLUTE MAXIMUM RATINGS

(Ta=25°C)

PARAMETER		SYMBOL	RATINGS	UNIT
Supply Voltage Range		V _{DD-GND}	4	V
Control Terminal Voltage		V _{id}	GND ~ V _{DD}	V
Analog Terminal Voltage		V _{ia}	V _{SS} ~ V _{DD}	V
Terminals Current	Supply Terminal	I _{DD} , I _{GND} , I _{AV}	50	mA
	OVH Terminal	I _{OVH}	50	
	Others	I _I	10	
Operating Temperature Range		T _{OPR}	0 ~ + 50	°C
Storage Temperature Range		T _{STG}	-40 ~ +125	°C

■ ELECTRICAL CHARACTERISTICS

 (V_{DD}=+3V, GND=0V, DC400mV Range, Ta=25°C)

PARAMETER		SYMBOL	CONDITIONS	MIN	TYP	MAX	UNIT	
Operating Voltage		V _{DD}		2.0	3.0	3.6	V	
Operating Current		I _{DD}	V _{DD} Terminal			1.0	mA	
		I _{POF}	V _{DD} Ter. in Auto Power Off		0.01			
Negative Supply Voltage		V _{SS}	V _{SS} Terminal		-2.8			
Low-Battery Detection Voltage		V _{BLD}	V _{DD} Terminal	2.2	2.4	2.6	V	
Linearity	Digital Display	Linn	Input Series Resistor=10MΩ			±0.1	%F.S.	
	Bargraph	Ling				±5		
Polarity Error	Digital Display	Epn				±0.1	%F.S.	
	Bargraph	Epg				±5		
Zero Reading Display		Zero			0	0	0	count
Sampling Time	Digital Display	T _{sn}				100		ms
	Capacitance M.	T _{snc}			500			
	Bargraph	T _{sg}			5			
Sampling Rate	Digital Display	Nrn			2		cyc/s	
	Capacitance M.	Nrnc			1			
	Bargraph	Nrg			20			
High Level Input Voltage		V _{IH}	FC1~4, RCO~3, KI1~KI5 Term.	2.2			V	
Low Level Input Voltage		V _{IL}	PON, KMS, RMS, RST, ARMS Term.			0.8		
Input Pull-Up Resistance		Ri	FC1~4, RCO~3, KI1~5, PON Tr. RST Terminal	100	300	500	kΩ	
Buzzer Driving Current		I _{OH1}	BZ Terminal V _{OH} =2.7V	0.25	0.75			
		I _{OL1}	V _{OL} =0.3V	0.25	0.75			
Output Current (1)		I _{OH2}	SOUT, STB Term. V _{OH} =2.6V	0.45	0.7		mA	
		I _{OL2}	CEND, RD1~4 Term. V _{OL} =0.4V	0.45	0.7			
Output Current (2)		I _{OH3}	FC1~4 Terminals V _{OH} =2.6V	0.45	0.7		mA	
		I _{OL3}	(Push Switch Mode) V _{OL} =0.4V	0.45	0.7			
Open Volt.in Resistor M.		V _{OHM}	Be used for Ω, ⤵ measurement		0.4		V	
Charging Volt.in Capa.M.		C _{CAP}	Be used for "C" measurement		1.0			
Input Leakage Current		I _{LO}	VI Terminal V _{IN} =0mV			10	pA	
		I _{LF}	V _{IN} =400mV			40		
LCD Driving Voltage	V _H	SEG ₁ ~ ₂₅ , COM ₁ ~ ₄ Terminals		2/3V _{DD}	2/3V _{DD}	2/3V _{DD}	V	
	V _L			-0.05	-0.05	+0.05		
				1/3V _{DD}	1/3V _{DD}	1/3V _{DD}		
				-0.05	-0.05	+0.05		

5

Note) LCD Driving Waveform
(1/4duty, DC400mV Range, Vin=0mV)

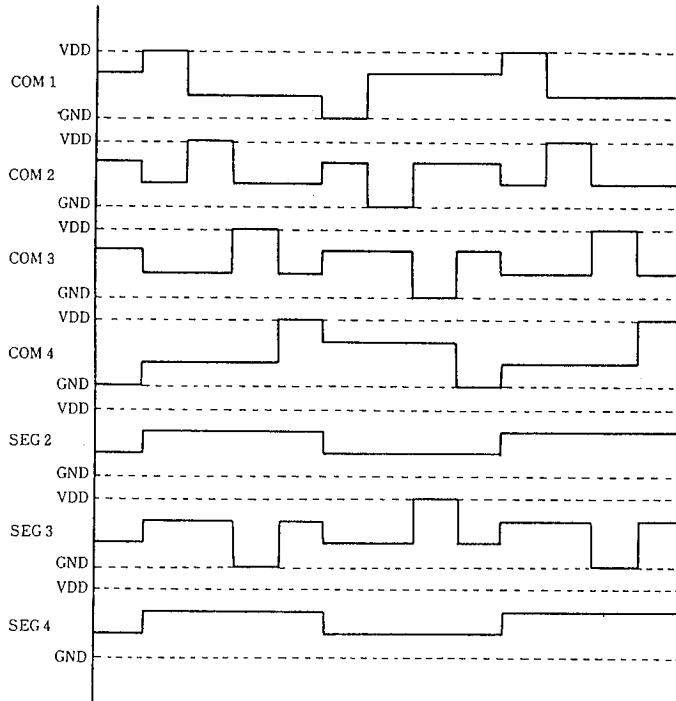

5

SWITCHING CHARACTERISTICS

($V_{DD}=+3V$, $GND=0V$, DC400mV Range, $f_{XT}=1MHz$, $T_a=25^{\circ}C$)

PARAMETER	SYMBOL	CONDITIONS	MIN	TYP	MAX	UNIT
Buzzer Output Frequency	FBZ	BZ Terminal		2.0		kHz
Serial Output Cycle	tout	SOUT Terminal		96		μs
Serial Clock Pulse Width	tckw	STB Terminal		48		
LCD Driver Frequency	FLCD	SEG ₁ ~ ₂₅ , COM ₁ ~ ₄ Term.		50		Hz
Relay Driver Pulse Width	twrd	RD1 ~ 4 Terminals		10		ms

APPLICATION CIRCUIT (1)

Circuit Example of Lock Switch

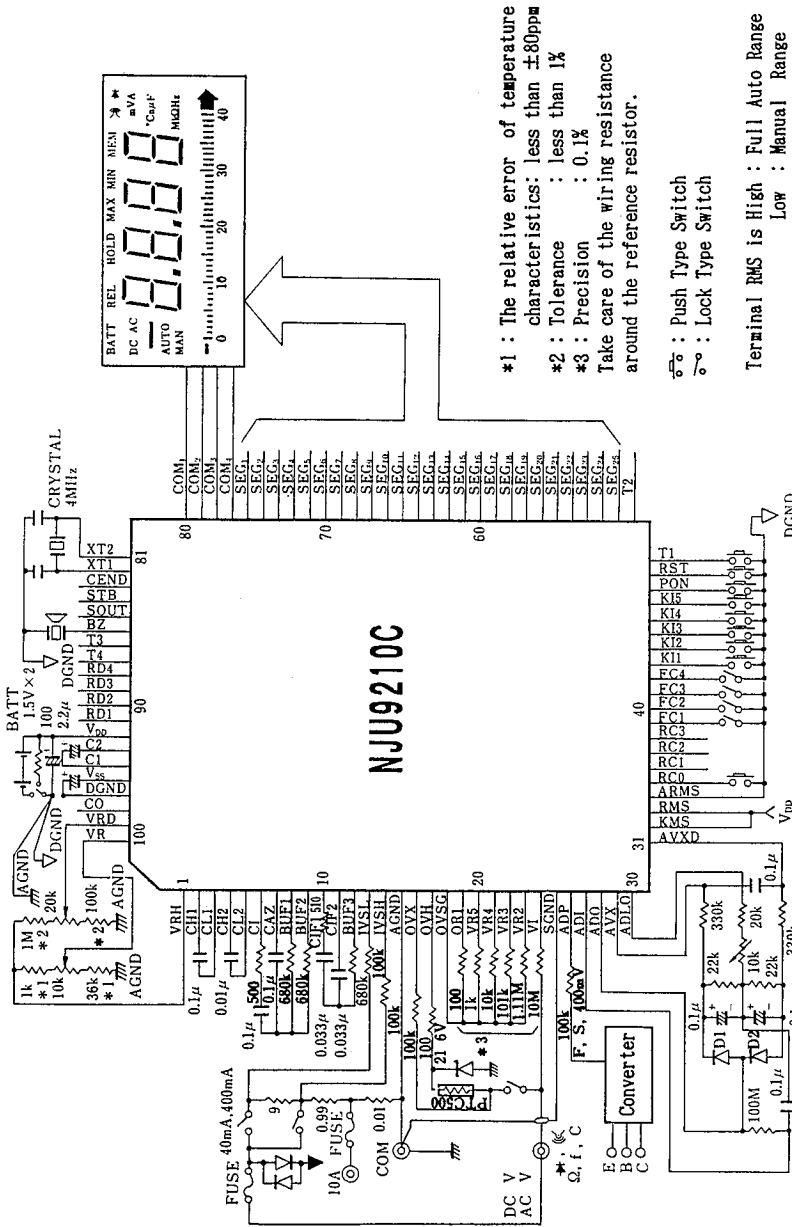

*1 : The relative error of temperature characteristics: less than $\pm 80\text{ppm}$
 *2 : Tolerance : less than 1%
 *3 : Precision : 0.1%
 Take care of the wiring resistance around the reference resistor.

⏏ : Push Type Switch
 ⏏ : Lock Type Switch

Terminal RMS is High : Full Auto Range
 Low : Manual Range

APPLICATION CIRCUIT (2)

Circuit Example of Push Switch

5

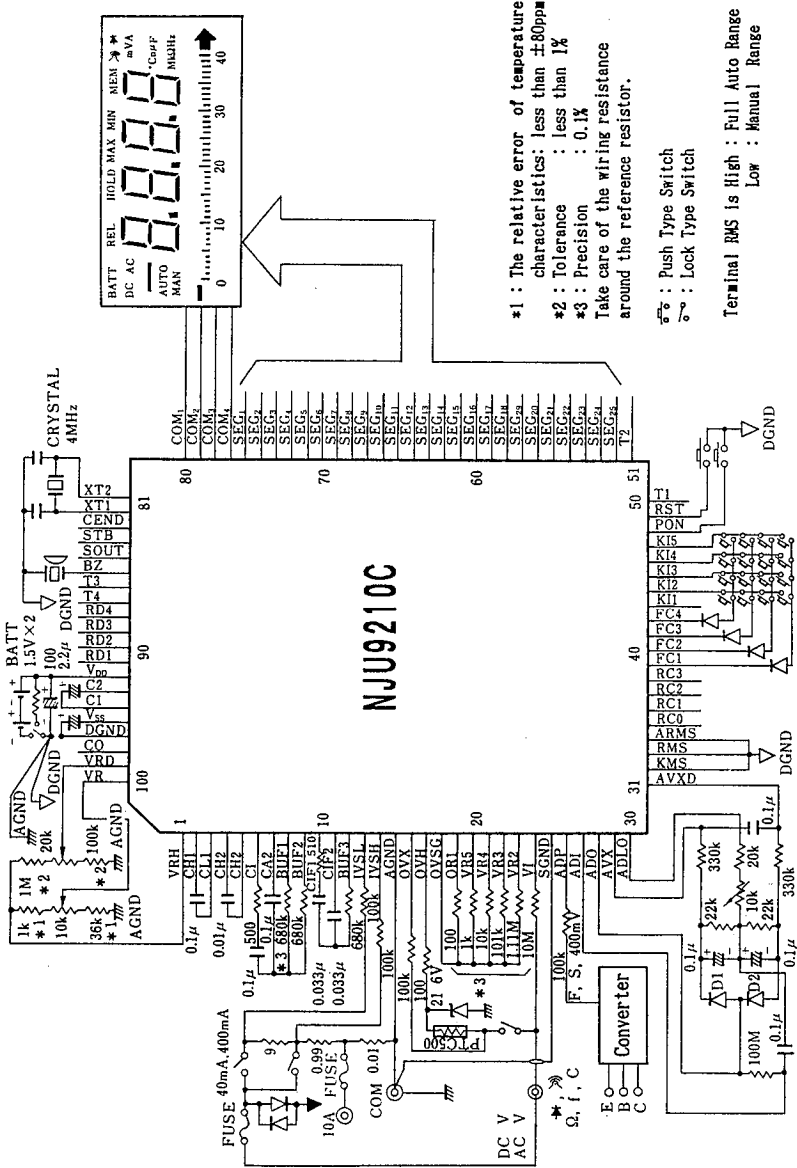

*1 : The relative error of temperature characteristics : less than $\pm 80ppm$
 *2 : Tolerance : less than 1%
 *3 : Precision : 0.1%
 Take care of the wiring resistance around the reference resistor.

$\overline{\text{P}}\text{S}$: Push Type Switch
 $\overline{\text{L}}\text{S}$: Lock Type Switch

Terminal RMS Is High : Full Auto Range
 Low : Manual Range

MEMO

[CAUTION]

The specifications on this databook are only given for information, without any guarantee as regards either mistakes or omissions. The application circuits in this databook are described only to show representative usages of the product and not intended for the guarantee or permission of any right including the industrial rights.