



■ Electrical Characteristics

(Unless otherwise specified, conditions shall be  $V_{IN}=5V$ ,  $I_o=2.5A$ ,  $V_o=3V[R_1=2k\Omega]T_a=25^\circ C$ )

Parameter	Symbol	Conditions	MIN.	TYP.	MAX.	Unit
Output saturation voltage	$V_{sat}$	$I_o=1A, No L, D, C_o$	-	0.9	1.5	V
Reference voltage	$V_{ref}$	-	1.235	1.26	1.285	V
Temperature fluctuation in reference voltage	$\Delta V_{ref}$	$T_j=0 \text{ to } 125^\circ C$	-	$\pm 0.5$	-	%
Load regulation	$ R_{egL} $	$I_o=0.2 \text{ to } 1A$	-	0.1	1.5	%
Line regulation	$ R_{egI} $	$V_{IN}=8 \text{ to } 35V$	-	0.5	2.5	%
Efficiency	$\eta$	$I_o=1A$	-	82	-	%
Oscillation frequency	$f_o$	-	80	100	120	kHz
Oscillation frequency temperature fluctuation	$\Delta f_o$	$T_j=0 \text{ to } 125^\circ C$	-	$\pm 2$	-	%
Maximum duty	$D_{MAX}$	④ terminal is open	90	-	-	%
Overcurrent detecting level	$I_L$	No L, D, C <sub>o</sub>	1.55	2.0	2.6	A
Charge current	$I_{CHG}$	②④ terminal is open	-15	-10	-5	$\mu A$
Input threshold voltage	$V_{THL}$	Duty=0%, ④ terminal=0V, ⑤ terminal	1.95	2.25	2.55	V
	$V_{THH}$	Duty= $D_{MAX}$ , ④ terminal is open, ⑤ terminal	3.25	3.55	3.85	V
On threshold voltage	$V_{THON}$	④ terminal=0V, ⑤ terminal	1.05	1.4	1.75	V
Stand-by current	$I_{SD}$	$V_{IN}=40V$ , ④ terminal=0V	-	150	400	$\mu A$
Output OFF-state consumption current	$I_{qs}$	$V_{IN}=40V$ , ⑤ terminal=3V	-	8	12	mA

■ Block Diagram

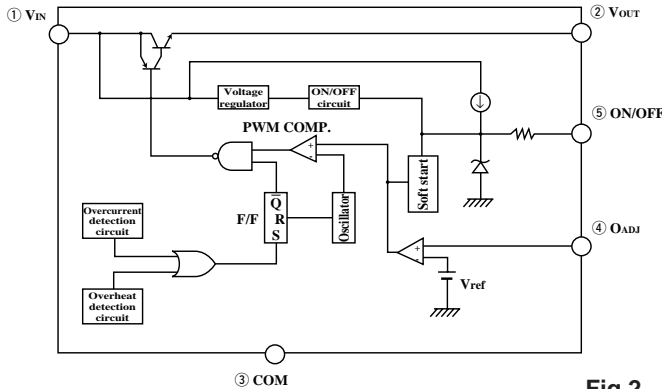
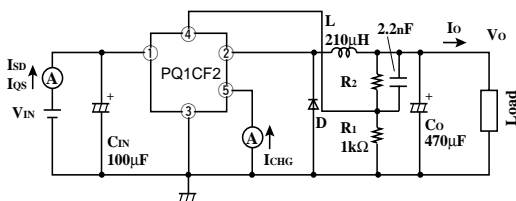
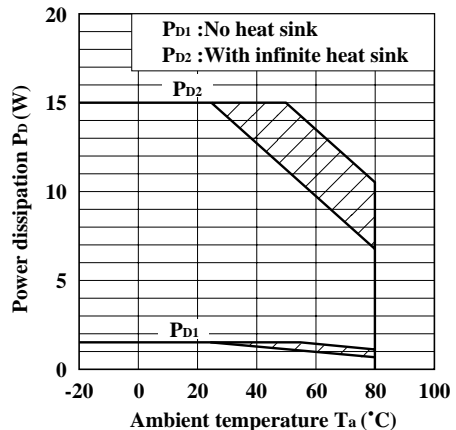

Fig.1 Test Circuit



L : HK-14D100-2110 (made by Toho Co.)  
 D : ERC80-004 (made by Fuji electronics Co.)

Fig.2 Power Dissipation vs. Ambient Temperature



Note) Oblique line portion : Overheat protection may operate in this area.

■ Step Down Type Circuit Diagram (5V output)

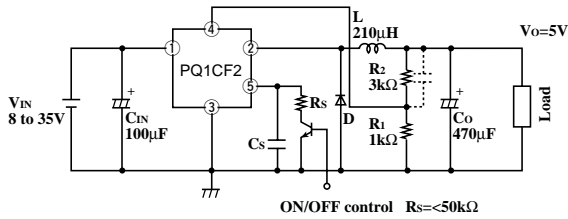

■ Polarity Inversion Type Circuit Diagram (-5V output)

