

# LH52B256

## CMOS 256K (32K × 8) Static RAM

### FEATURES

- Access Times: 70/90/100 ns
- Automatic Power Down During Long Read Cycles
- Low-Power Standby When Deselected
- TTL Compatible I/O
- Single +5 V Power Supply
- Fully-Static Operation
- 2 V Data Retention
- Packages:
  - 28-Pin, 600-mil DIP
  - 28-Pin, 300-mil SK-DIP
  - 28-Pin, 450-mil SOP
  - 28-Pin, 8 × 13 mm<sup>2</sup> TSOP (Type I)

### FUNCTIONAL DESCRIPTION

The LH52B256 is a high-density 262,144 bit static RAM organized as 32K × 8. An efficient design is obtained with a CMOS periphery and a matrix constructed with polysilicon load memory cells.

This RAM is fully static in operation. The Chip Enable ( $\overline{CE}$ ) control permits Read and Write operations when active (LOW) or places the RAM in a low-power standby mode when inactive (HIGH). Standby power ( $I_{SB1}$ ) drops to its lowest level if  $\overline{CE}$  is raised to within 0.2 V of  $V_{CC}$ .

Write cycles occur when both Chip Enable ( $\overline{CE}$ ) and Write Enable ( $\overline{WE}$ ) are LOW. Data is transferred from the I/O pins to the memory location specified by the 15 address lines. The proper use of the Output Enable control ( $\overline{OE}$ ) can prevent bus contention.

When  $\overline{CE}$  is LOW and  $\overline{WE}$  is HIGH, a static Read will occur at the memory location specified by the address lines.  $\overline{OE}$  must be brought LOW to enable the outputs. Since the device is fully static in operation, new Read cycles can be performed by simply changing the address. An Automatic Power Down feature decreases current consumption when Read cycles extend beyond their minimum cycle time.

High-frequency design techniques should be employed to obtain the best performance from this device. Solid, low-impedance power and ground planes, with high-frequency decoupling capacitors, are recommended. Series termination of the inputs should be considered when transmission line effects occur.

### PIN CONNECTIONS

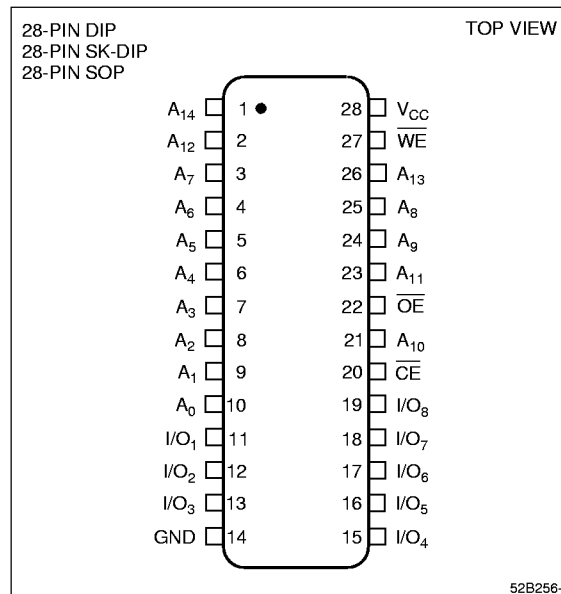

Figure 1. Pin Connections for DIP and SOP Packages

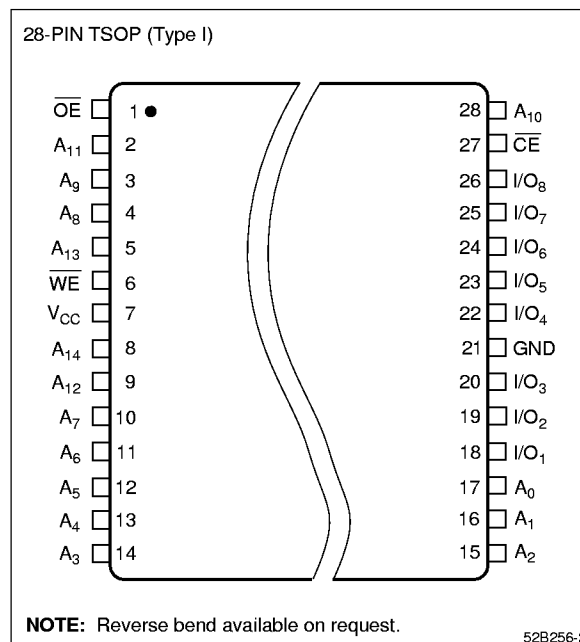

Figure 2. Pin Connections for TSOP Package

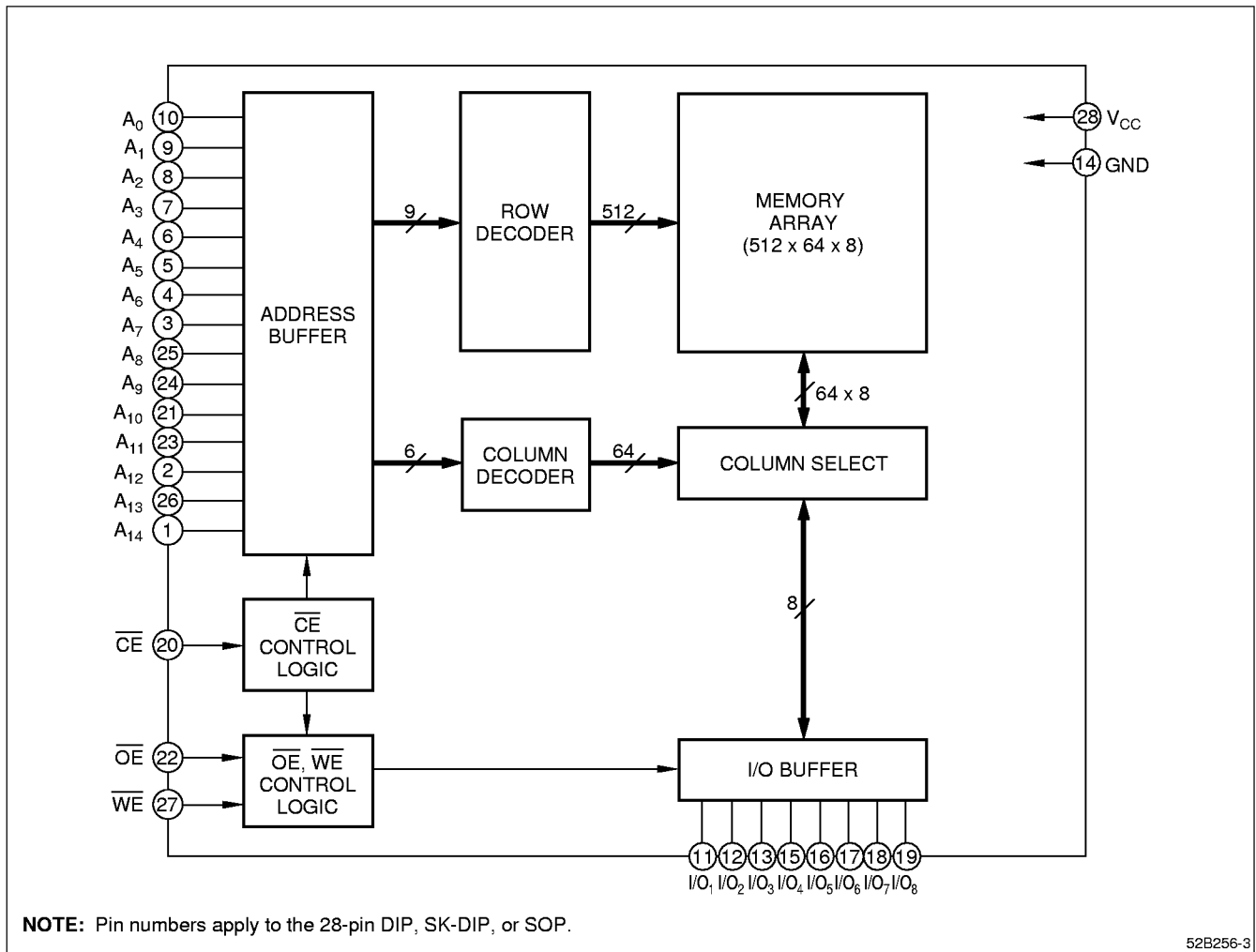

Figure 3. LH52B256 Block Diagram

**PIN DESCRIPTIONS**

PIN	DESCRIPTION
A <sub>0</sub> – A <sub>14</sub>	Address Inputs
$\overline{CE}$	Chip Enable input
$\overline{WE}$	Write Enable input
$\overline{OE}$	Output Enable input

PIN	DESCRIPTION
I/O <sub>1</sub> – I/O <sub>8</sub>	Data Input/Output
V <sub>CC</sub>	Power Supply
GND	Ground

## TRUTH TABLE

$\overline{CE}$	$\overline{WE}$	$\overline{OE}$	MODE	I/O <sub>1</sub> – I/O <sub>8</sub>	SUPPLY CURRENT	NOTE
H	X	X	Deselect	High-Z	Standby (I <sub>SB</sub> )	1
L	L	X	Write	D <sub>IN</sub>	Operating (I <sub>CC</sub> )	1
L	H	L	Read	D <sub>OUT</sub>	Operating (I <sub>CC</sub> )	
L	H	H	Output Disable	High-Z	Operating (I <sub>CC</sub> )	

## NOTE:

- X = H or L.

## ABSOLUTE MAXIMUM RATINGS

PARAMETER	SYMBOL	RATING	UNIT	NOTE
Supply Voltage	V <sub>CC</sub>	-0.5 to +7.0	V	1
Input Voltage	V <sub>IN</sub>	-0.5 to V <sub>CC</sub> + 0.5	V	1, 2
Operating Temperature	T <sub>opr</sub>	0 to +70	°C	
Storage Temperature	T <sub>stg</sub>	-65 to +150	°C	

## NOTES:

- The maximum applicable voltage on any pin with respect to GND.
- V<sub>IN</sub> (MIN.) = -3.0 V for pulse width ≤ 50 ns.

RECOMMENDED OPERATING CONDITIONS (T<sub>A</sub> = 0°C to +70°C)

PARAMETER	SYMBOL	MIN.	TYP.	MAX.	UNIT	NOTE
Supply Voltage	V <sub>CC</sub>	4.5	5.0	5.5	V	
Input Voltage	V <sub>IH</sub>	2.2		V <sub>CC</sub> + 0.5	V	
	V <sub>IL</sub>	-0.5		0.8	V	1

## NOTE:

- V<sub>IN</sub> (MIN.) = -3.0 V for pulse width ≤ 50 ns.

DC CHARACTERISTICS (V<sub>CC</sub> = 5 V ±10%, T<sub>A</sub> = 0°C to +70°C)

PARAMETER	SYMBOL	CONDITIONS	MIN.	TYP.	MAX.	UNIT
Input Leakage Current	I <sub>LI</sub>	V <sub>IN</sub> = 0 to V <sub>CC</sub>	-1		1	μA
Output Leakage Current	I <sub>LO</sub>	$\overline{CE}$ or $\overline{OE}$ = V <sub>IH</sub> , V <sub>IO</sub> = 0 to V <sub>CC</sub>	-1		1	μA
Operating Current	I <sub>CC</sub>	Minimum Cycle V <sub>IN</sub> = V <sub>IL</sub> or V <sub>IH</sub> I <sub>VO</sub> = 0 mA, $\overline{CE}$ = V <sub>IL</sub>			70	mA
		t <sub>RC</sub> , t <sub>WC</sub> = 1 μs V <sub>IN</sub> = V <sub>IL</sub> or V <sub>IH</sub> I <sub>VO</sub> = 0 mA, $\overline{CE}$ = V <sub>IL</sub>		15	30	mA
Standby Current	I <sub>SB1</sub>	$\overline{CE}$ = V <sub>IH</sub>			3.0	mA
	I <sub>SB</sub>	$\overline{CE}$ ≥ V <sub>CC</sub> - 0.2 V			40	μA
Output Voltage	V <sub>OL</sub>	I <sub>OL</sub> = 2.1 mA			0.4	V
	V <sub>OH</sub>	I <sub>OH</sub> = -1.0 mA	2.4			V

## AC CHARACTERISTICS

### (1) READ CYCLE ( $V_{CC} = 5\text{ V} \pm 10\%$ , $T_A = 0^\circ\text{C to } +70^\circ\text{C}$ )

DESCRIPTION	SYMBOL	LH52B256-70		LH52B256-90		LH52B256-10		UNIT	NOTE
		MIN.	MAX.	MIN.	MAX.	MIN.	MAX.		
Read Cycle Time	$t_{RC}$	70		90		100		ns	
Address Access Time	$t_{AA}$		70		90		100	ns	
Chip Enable Access Time	$t_{ACE}$		70		90		100	ns	
Output Enable Access Time	$t_{OE}$		40		50		50	ns	
Output Hold Time	$t_{OH}$	10		10		10		ns	
$\overline{CE}$ Low to Output in Low-Z	$t_{LZ}$	10		10		10		ns	1
$\overline{OE}$ Low to Output in Low-Z	$t_{OLZ}$	5		5		5		ns	1
$\overline{CE}$ High to Output in High-Z	$t_{HZ}$	0	35	0	40	0	40	ns	1
$\overline{OE}$ High to Output High-Z	$t_{OHZ}$	0	35	0	40	0	40	ns	1

### (2) WRITE CYCLE ( $V_{CC} = 5\text{ V} \pm 10\%$ , $T_A = 0^\circ\text{C to } +70^\circ\text{C}$ )

DESCRIPTION	SYMBOL	LH52B256-70		LH52B256-90		LH52B256-10		UNIT	NOTE
		MIN.	MAX.	MIN.	MAX.	MIN.	MAX.		
Write Cycle Time	$t_{WC}$	70		90		100		ns	
$\overline{CE}$ Low to End of Write	$t_{CW}$	60		70		80		ns	
Address Valid to End of Write	$t_{AW}$	60		70		80		ns	
Address Setup Time	$t_{AS}$	0		0		0		ns	
Write Pulse Width	$t_{WP}$	55		65		75		ns	
Write Recovery Time	$t_{WR}$	0		0		0		ns	
Input Data Setup Time	$t_{DW}$	30		35		40		ns	
Input Data Hold Time	$t_{DH}$	0		0		0		ns	
$\overline{WE}$ High to Output in High-Z	$t_{OW}$	5		5		5		ns	1
$\overline{WE}$ Low to Output in High-Z	$t_{WZ}$	0	40	0	40	0	40	ns	1
$\overline{OE}$ High to Output in High-Z	$t_{OHZ}$	0	35	0	40	0	40	ns	1

#### NOTE:

- Active output to high-impedance and high-impedance to output active tests specified for a  $\pm 200\text{ mV}$  transition from steady state levels into the test load.

**AC TEST CONDITIONS**

PARAMETER	RATING	NOTE
Input Voltage Amplitude	0.6 to 2.4 V	
Input Rise/Fall Time	10 ns	
Timing Reference Level	1.5 V	
Output Load Conditions	1TTL + CL (100 pF)	1

**NOTE:**

1. Includes scope and jig capacitance.

**CAPACITANCE <sup>1</sup> (T<sub>A</sub> = 25°C, f = 1 MHz)**

PARAMETER	SYMBOL	CONDITIONS	MIN.	TYP.	MAX.	UNIT
Input Capacitance	C <sub>IN</sub>	V <sub>IN</sub> = 0 V			9	pF
Input/Output Capacitance	C <sub>I/O</sub>	V <sub>I/O</sub> = 0 V			10	pF

**NOTE:**

1. This parameter is sampled and not production tested.

**DATA RETENTION CHARACTERISTICS (T<sub>A</sub> = 0°C to +70°C)**

PARAMETER	SYMBOL	CONDITIONS	MIN.	TYP.	MAX.	UNIT	NOTE
Data Retention Voltage	V <sub>CCDR</sub>	$\overline{CE} \geq V_{CCDR} - 0.2 \text{ V}$	2.0		5.5	V	
Data Retention Current	I <sub>CCDR</sub>	$V_{CCDR} = 3.0 \text{ V}$ $\overline{CE} \geq V_{CCDR} - 0.2 \text{ V}$			1	μA	
					3		
					20		
$\overline{CE}$ Setup Time	t <sub>CDR</sub>		0			ns	
$\overline{CE}$ Hold Time	t <sub>R</sub>		t <sub>RC</sub>			ns	1

**NOTE:**

1. t<sub>RC</sub> = Read cycle time

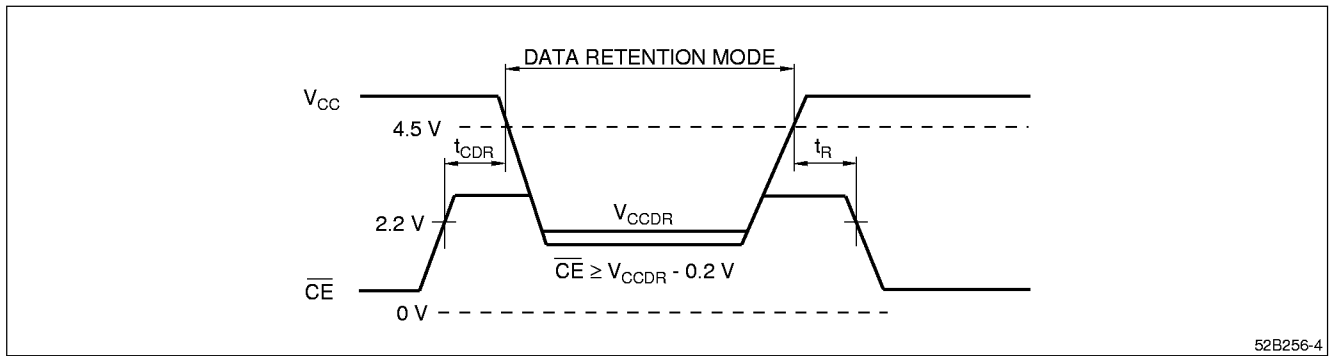

52B256-4

Figure 4. Data Retention Characteristics

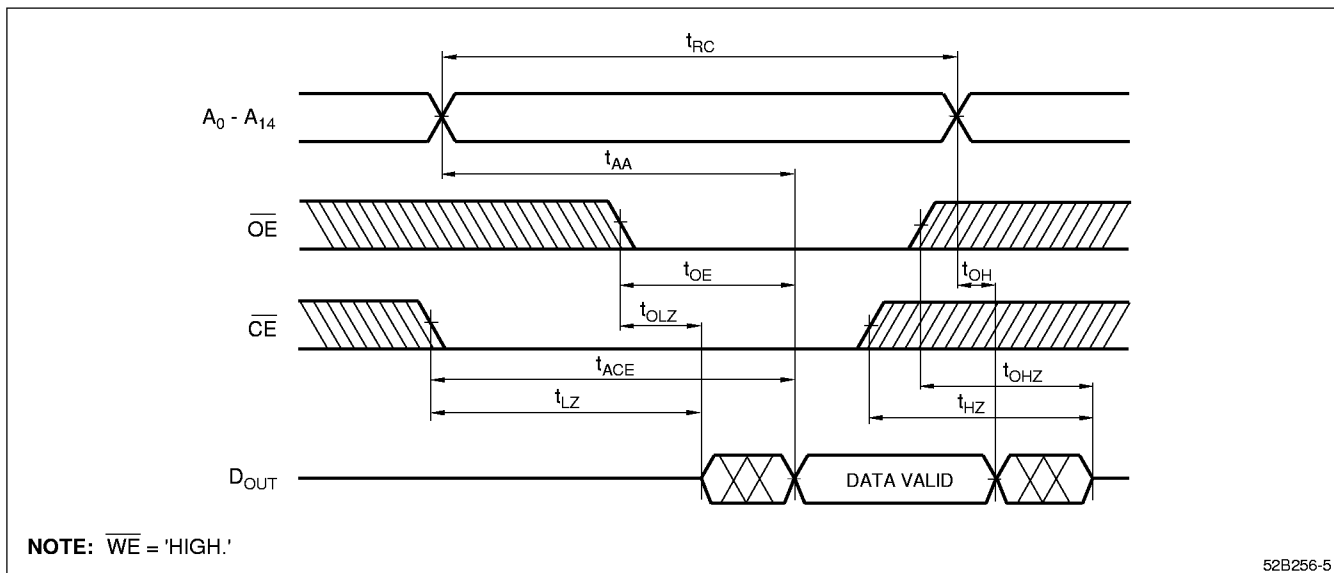

NOTE:  $\overline{WE}$  = 'HIGH.'

52B256-5

Figure 5. Read Cycle

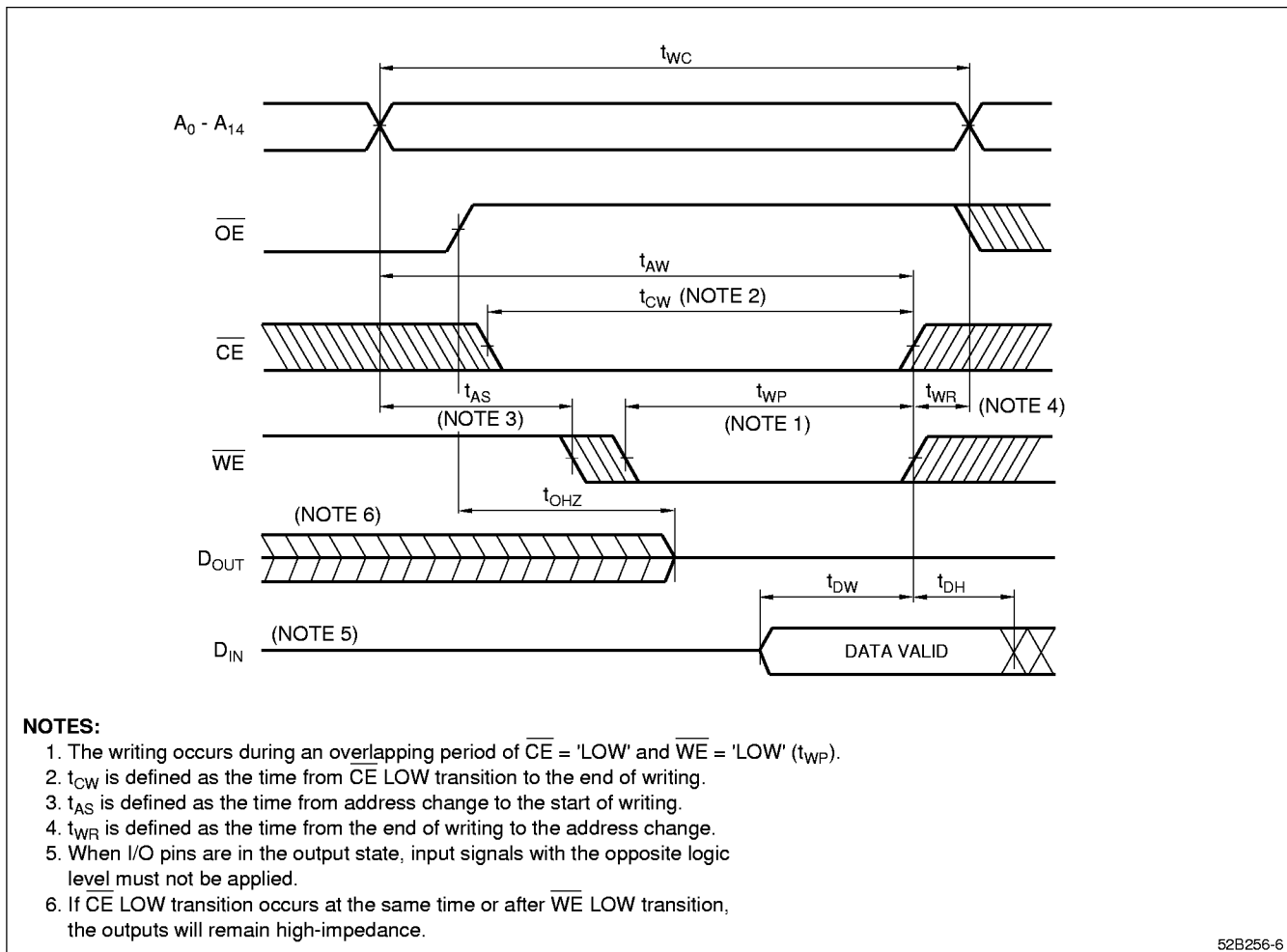

52B256-6

Figure 6. Write Cycle 1 ( $\overline{OE}$  Controlled)

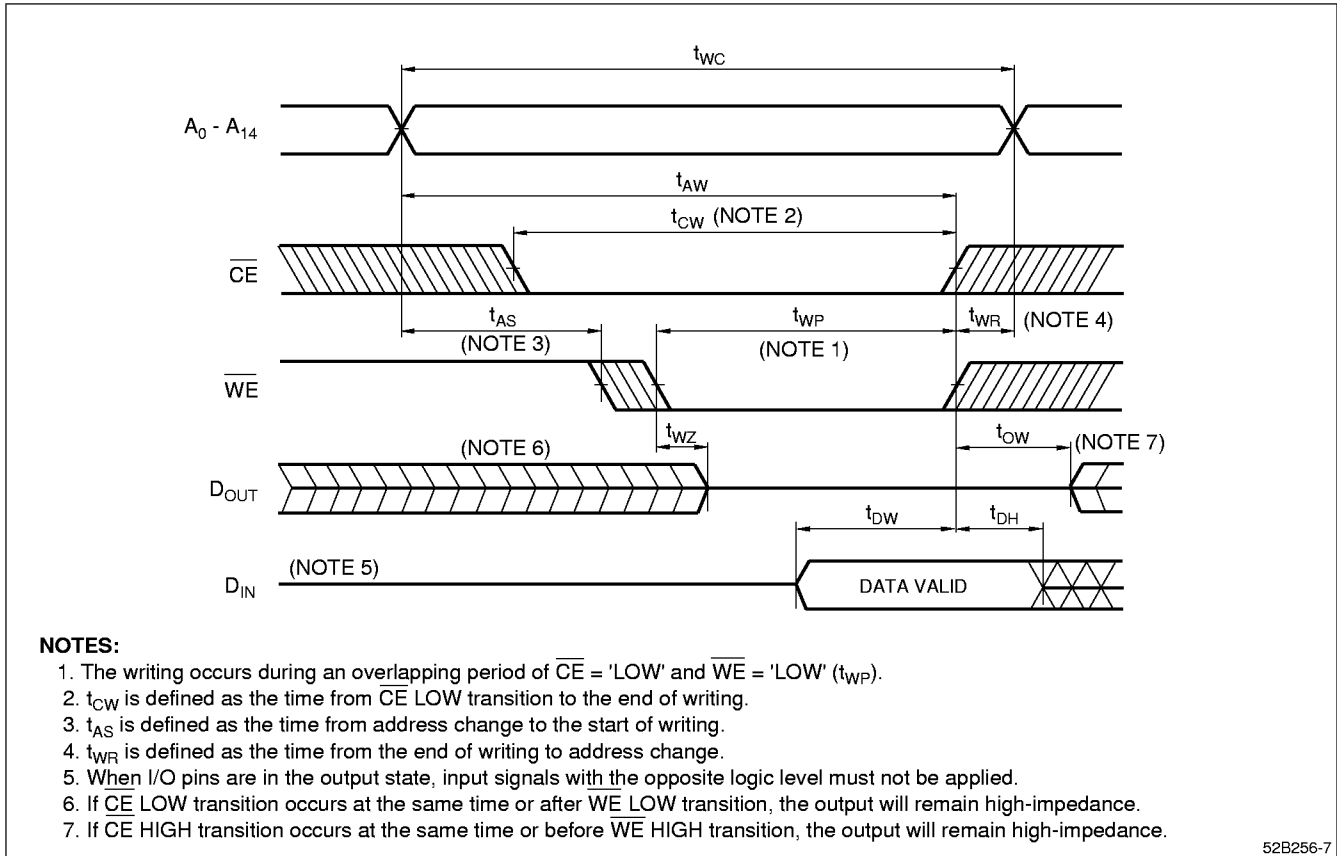
Figure 7. Write Cycle No. 2 ( $\overline{OE}$  Low Fixed)



PACKAGE DIAGRAMS

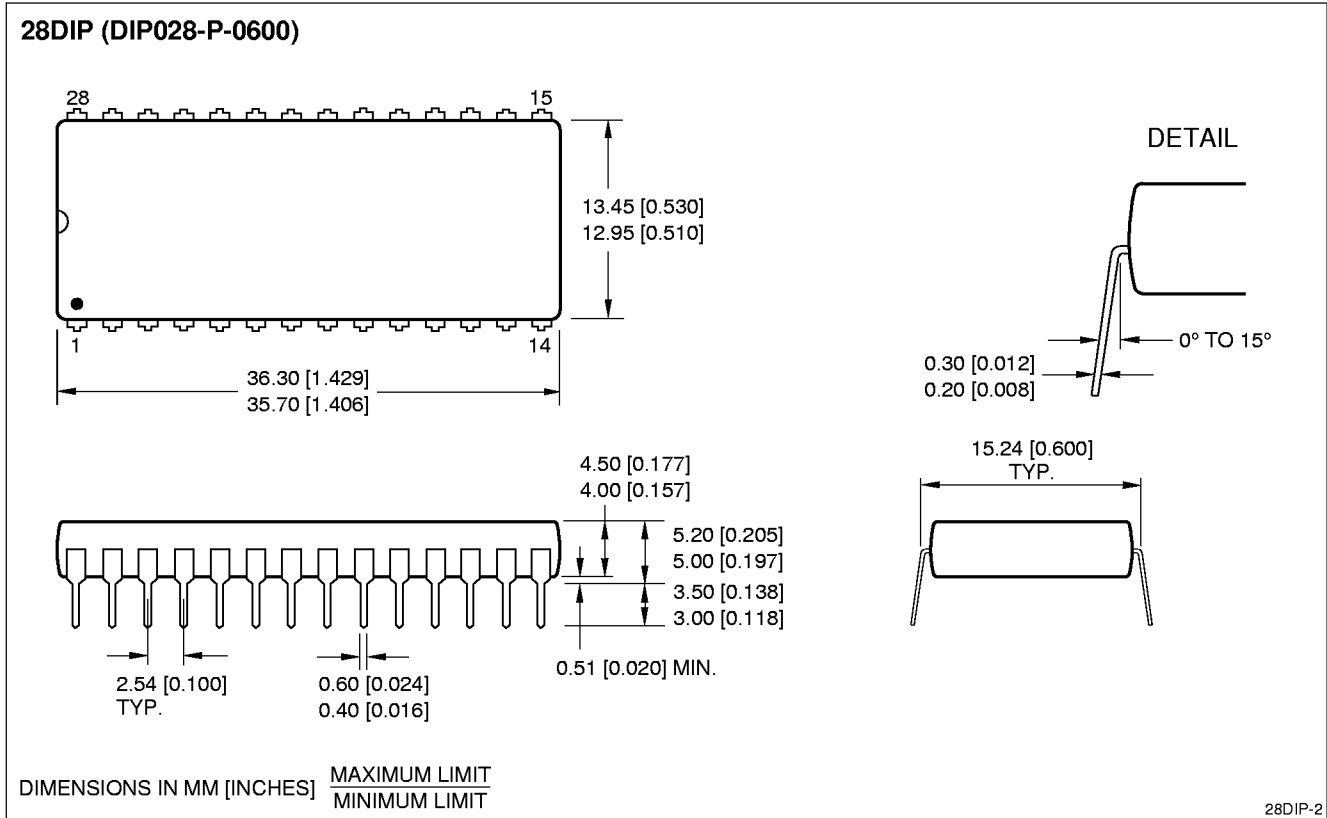

28-pin, 600-mil DIP

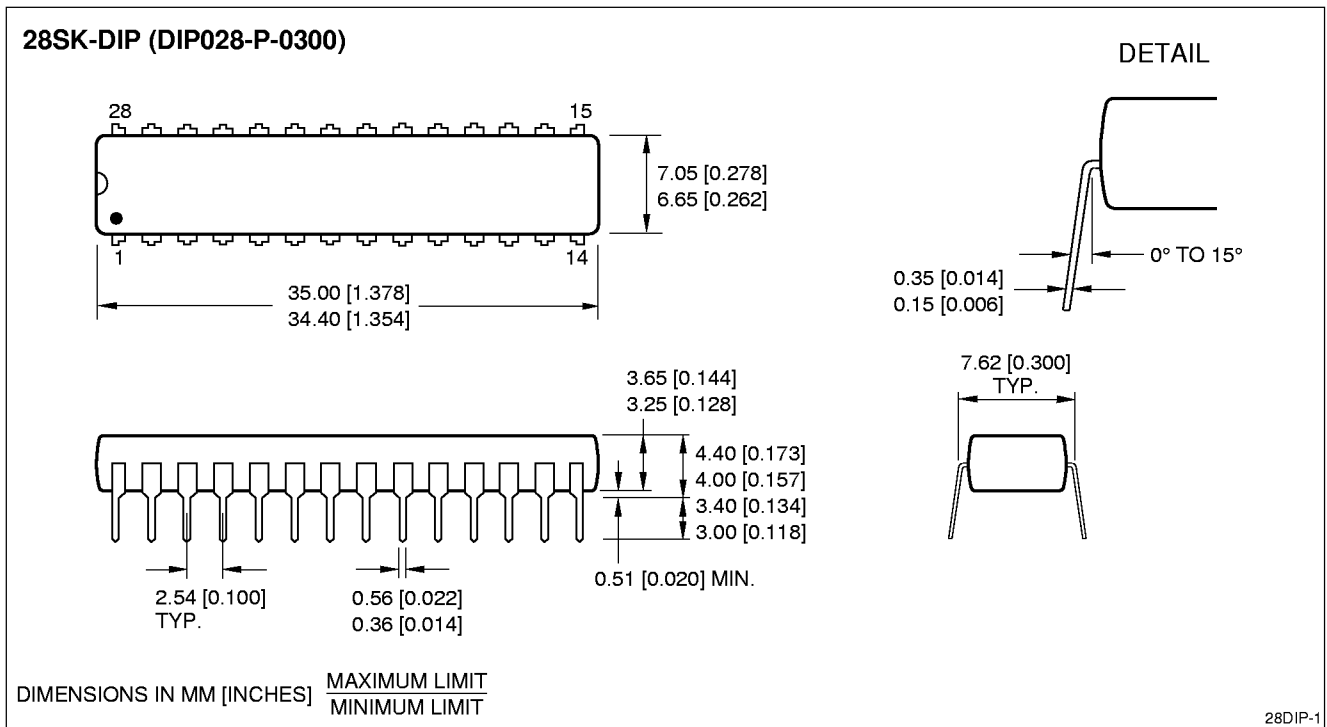

28-pin, 300-mil DIP

28SOP (SOP028-P-0450)

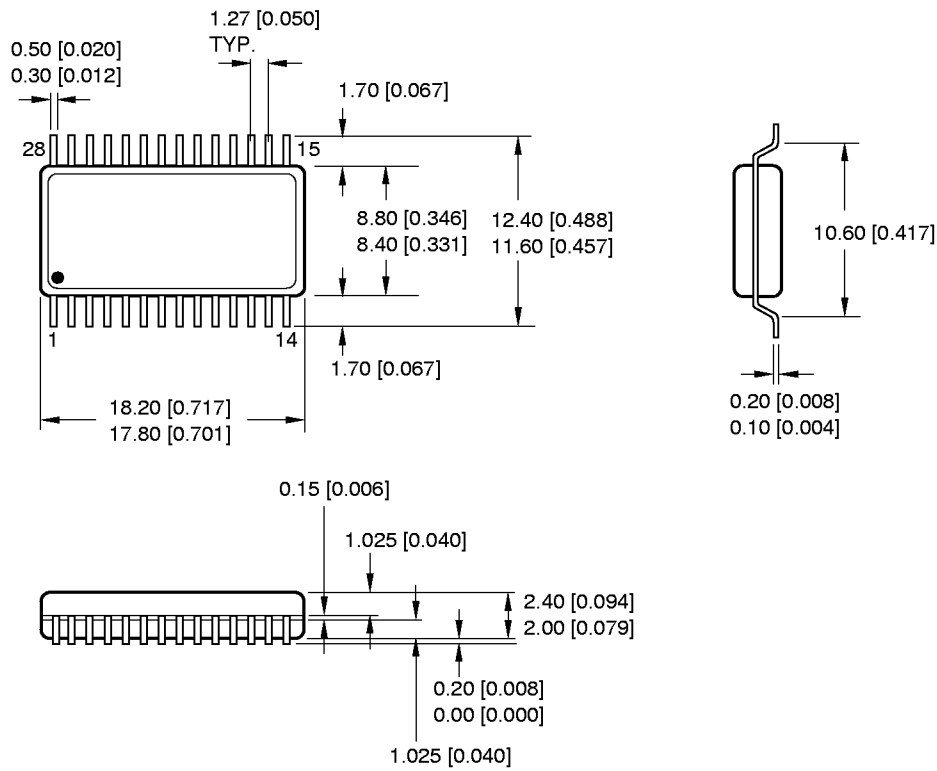

DIMENSIONS IN MM [INCHES]    MAXIMUM LIMIT  
    MINIMUM LIMIT

28SOP

28-pin, 450-mil SOP

28TSOP (TSOP028-P-0813)

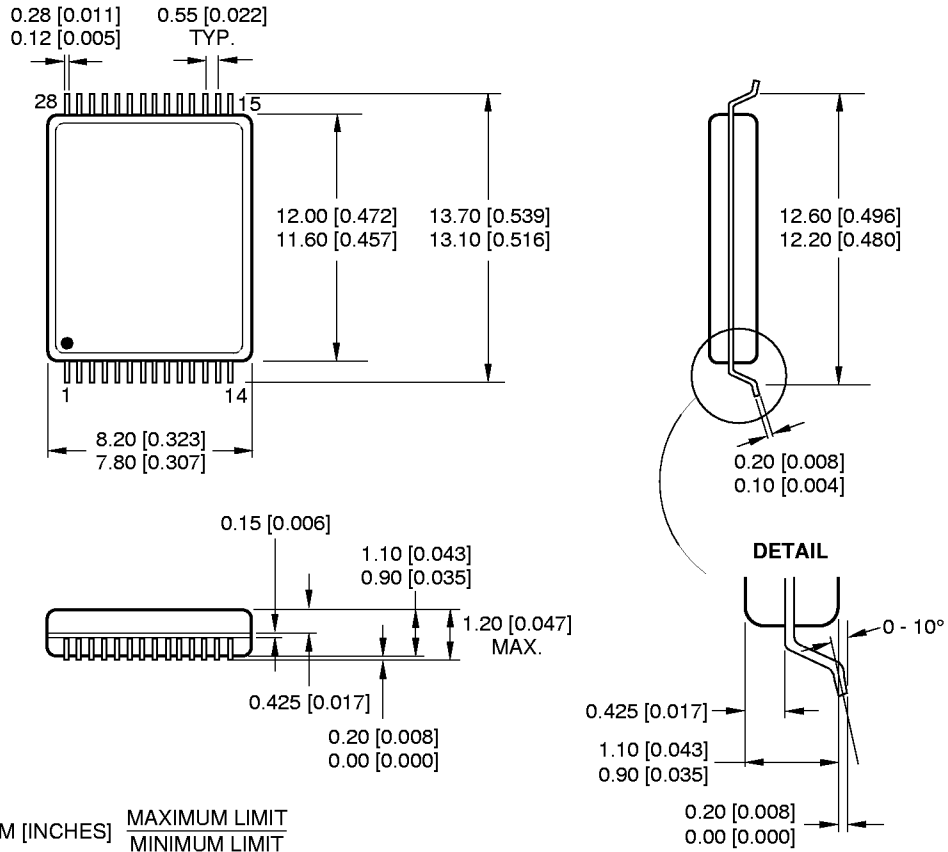

28TSOP

28-pin, 8 × 13 mm<sup>2</sup> TSOP (Type I)

ORDERING INFORMATION

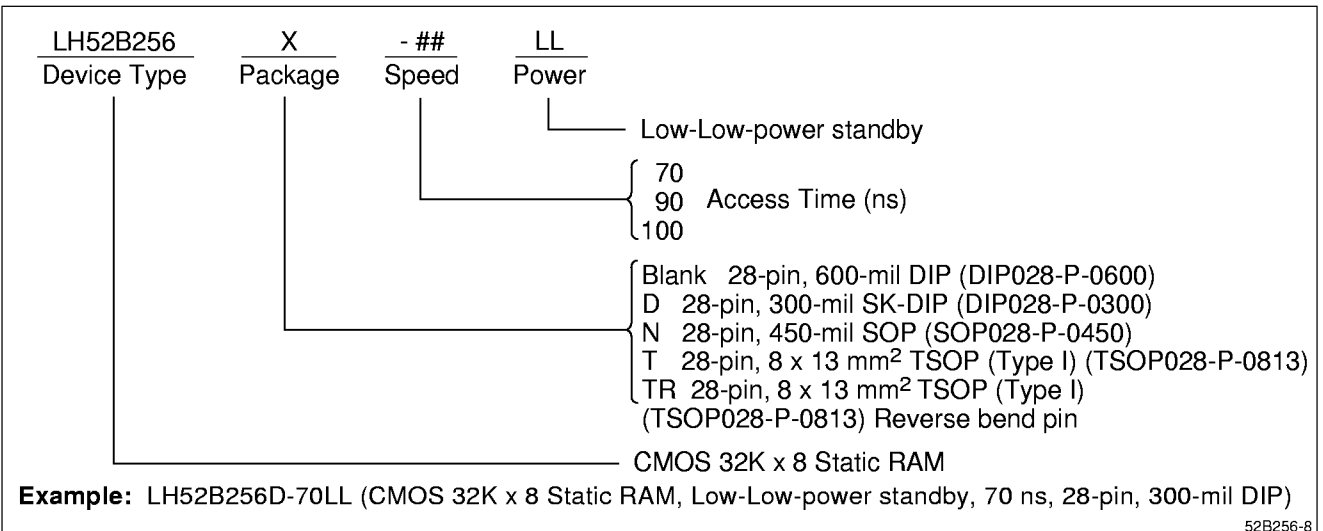

52B256-8