



Low-Cost, Mono/Stereo, 1.4W Differential Audio Power Amplifiers

MAX9718/MAX9719

General Description

The MAX9718/MAX9719 differential input audio power amplifiers are ideal for portable audio devices with internal speakers. The differential input structure improves noise rejection and provides common-mode rejection. A bridge-tied load (BTL) architecture minimizes external component count, while providing high-quality, power audio amplification. The MAX9718 is a single-channel amplifier while the MAX9719 is a dual-channel amplifier for stereo systems. Both devices deliver 1.4W continuous average power per channel to a 4Ω load with less than 1% THD+N while operating from a single +5V supply. The devices are available as adjustable gain amplifiers or with internally fixed gains of 0dB, 3dB, and 6dB to reduce component count.

A shutdown input disables the bias generator and amplifiers and reduces quiescent current consumption to less than 100nA. The MAX9718 shutdown input can be set as active high or active low. These devices feature Maxim's comprehensive click-and-pop suppression circuitry that reduces audible clicks and pops during startup and shutdown.

The MAX9718 is pin compatible with the LM4895, and is available in 9-bump UCSP™, 10-pin TDFN, and 10-pin μMAX® packages. The MAX9719 is available in 16-pin TQFN, 16-pin TSSOP, and 16-bump UCSP packages. Both devices operate over the -40°C to +85°C extended temperature range.

Applications

Mobile Phones
PDAs
Portable Devices

Features

- ◆ 2.7V to 5.5V Single-Supply Operation
- ◆ Very High -93dB PSRR at 217Hz
- ◆ 1.4W into 4Ω at 1% THD+N (per Channel)
- ◆ Differential Input
- ◆ Internal Fixed Gain to Reduce Component Count
- ◆ Adjustable Gain Option (MAX9718A/MAX9719A)
- ◆ 100nA Low-Power Shutdown Mode
- ◆ No Audible Clicks or Pops at Power-Up/Down
- ◆ Improved Performance Pin-Compatible Upgrade to LM4895 (MAX9718D)

Ordering Information

| PART | TEMP RANGE | PIN-PACKAGE | GAIN (dB) |
|---------------|----------------|-------------|-----------|
| MAX9718AEBL-T | -40°C to +85°C | 3 x 3 UCSP | Adj |
| MAX9718AETB | -40°C to +85°C | 10 TDFN-EP* | Adj |
| MAX9718AEUB | -40°C to +85°C | 10 μMAX-EP* | Adj |

*EP = Exposed paddle.

Ordering Information continued at end of data sheet.

Pin Configurations appear at end of data sheet.

UCSP is a trademark of Maxim Integrated Products, Inc.

μMAX is a registered trademark of Maxim Integrated Products, Inc.

Simplified Block Diagram

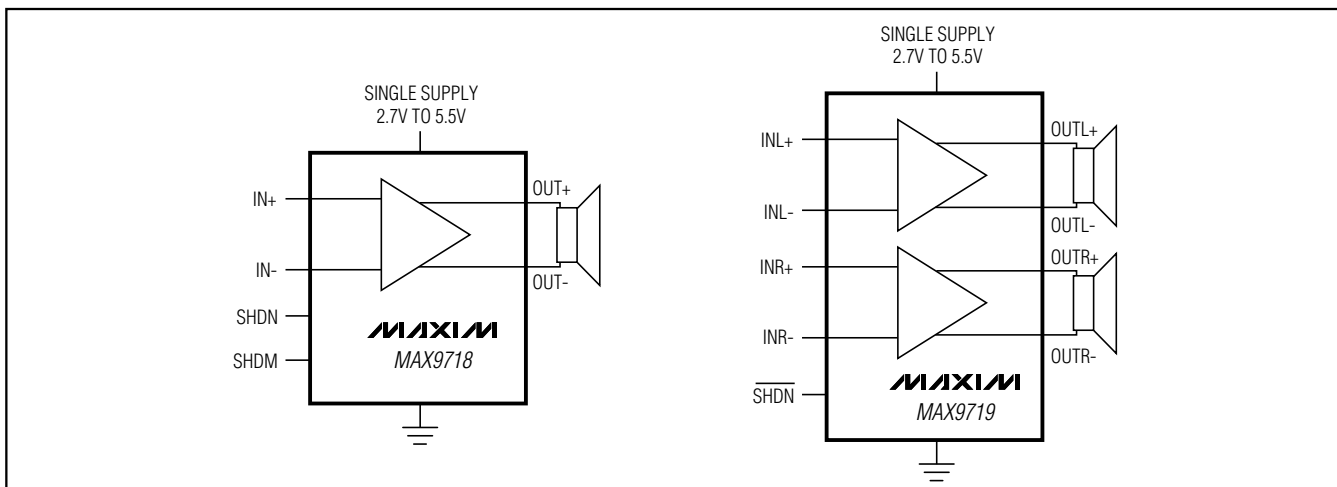

Low-Cost, Mono/Stereo, 1.4W Differential Audio Power Amplifiers

ABSOLUTE MAXIMUM RATINGS

| | |
|--|-----------------------------------|
| Supply Voltage (V _{CC} to GND) | -0.3V to +6V |
| Any Other Pin to GND | -0.3V to (V _{CC} + 0.3V) |
| IN ₋ , BIAS, SHDM, SHDN, SHDN ₋ Continuous Current | 20mA |
| OUT ₋ Short-Circuit Duration to GND or V _{CC} | Continuous |
| Continuous Power Dissipation (T _A = +70°C) | |
| 9-Bump UCSP (derate 5.2mW/°C above +70°C) | 412mW |
| 10-Pin TDFN (derate 24.4mW/°C above +70°C) | 1951mW |
| 10-Pin μMAX (derate 10.3mW/°C above +70°C) | 825mW |
| 16-Bump UCSP (derate 8.2mW/°C above +70°C) | 659mW |
| 16-Pin TQFN (derate 16.9mW/°C above +70°C) | 1349mW |
| 16-Pin TSSOP (derate 21.3mW/°C above +70°C) | 1702mW |

| | |
|-------------------------------------|-----------------|
| Operating Temperature Range | -40°C to +85°C |
| Junction Temperature | +150°C |
| Storage Temperature Range | -65°C to +150°C |
| Bump Temperature (soldering) Reflow | +235°C |
| Lead Temperature (soldering, 10s) | +300°C |

Stresses beyond those listed under "Absolute Maximum Ratings" may cause permanent damage to the device. These are stress ratings only, and functional operation of the device at these or any other conditions beyond those indicated in the operational sections of the specifications is not implied. Exposure to absolute maximum rating conditions for extended periods may affect device reliability.

ELECTRICAL CHARACTERISTICS—5V Supply

(V_{CC} = 5V, GND = 0, SHDN/SHDN₋ = V_{CC} (MAX9718/MAX9719), SHDM = GND (MAX9718), R_{IN} = R_F = 10kΩ (MAX971_A), T_A = +25°C. C_{BIAS} = 0.1μF, no load. Typical values are at T_A = +25°C, unless otherwise noted.) (Note 1)

| PARAMETER | SYMBOL | CONDITIONS | | MIN | TYP | MAX | UNITS |
|--|-------------------|---|--|-------------------------|-----------------------|-------------------------|-------|
| Supply Voltage | V _{CC} | | | 2.7 | | 5.5 | V |
| Supply Current | I _{CC} | V _{IN-} = V _{IN+} = V _{BIAS} , T _A = -40°C to +85°C, per amplifier (Note 2) | | | 5.0 | 7.5 | mA |
| Shutdown Supply Current | I _{SHDN} | SHDN = SHDM = SHDN ₋ = GND, per amplifier | | | 0.1 | 1 | μA |
| SHDN ₋ , SHDN, SHDM Threshold | V _{IH} | | | 0.7 × V _{CC} | | | V |
| | V _{IL} | | | 0.3 × V _{CC} | | | |
| Common-Mode Bias Voltage | V _{BIAS} | (Note 3) | | V _{CC} /2 - 5% | V _{CC} /2 | V _{CC} /2 + 5% | V |
| Output Offset Voltage | V _{OS} | V _{IN-} = V _{IN+} = V _{BIAS} | A _V = 0dB, MAX971_A, MAX971_B | | ±1 | ±10 | mV |
| | | | A _V = 3dB, MAX971_C | | ±1 | ±15 | |
| | | | A _V = 6dB, MAX971_D | | ±1 | ±20 | |
| Common-Mode Input Voltage | V _{IC} | Inferred from CMRR test | A _V = 0dB, MAX971_B | 0.5 | | V _{CC} - 0.5 | V |
| | | | A _V = 3dB, MAX971_C | 0.5 | | V _{CC} - 0.6 | |
| | | | A _V = 6dB, MAX971_D | 0.5 | | V _{CC} - 0.8 | |
| | | External gain, MAX971_A | 0.5 | | V _{CC} - 1.2 | | |
| Input Impedance | R _{IN} | MAX971_B, MAX971_C, MAX971_D | | 10 | 15 | 20 | kΩ |
| Common-Mode Rejection Ratio | CMRR | | | -50 | -60 | | dB |
| | | f _n = 1kHz | | | -60 | | |
| Power-Supply Rejection Ratio | PSRR | V _{IN-} = V _{IN+} = V _{BIAS} , V _{RIPPLE} = 200mV _{P-P} , R _L = 8Ω, C _{BIAS} = 1μF | f = 217Hz | | -93 | | dB |
| | | | f = 1kHz | | -90 | | |
| Output Power | P _{OUT} | THD+N = 1%, f _{IN} = 1kHz (Note 4) | R _L = 8Ω | 0.8 | 1.1 | | W |
| | | | R _L = 4Ω | | 1.4 | | |
| Total Harmonic Distortion Plus Noise | THD+N | R _L = 8Ω, f _{IN} = 1kHz, P _{OUT} = 0.75W, V _{CC} = 5V, A _V = 6dB (Note 5) | | | 0.002 | | % |

Low-Cost, Mono/Stereo, 1.4W Differential Audio Power Amplifiers

MAX9718/MAX9719

ELECTRICAL CHARACTERISTICS—5V Supply (continued)

($V_{CC} = 5V$, $GND = 0$, $\overline{SHDN}/\overline{SHDN} = V_{CC}$ (MAX9718/MAX9719), $\overline{SHDM} = GND$ (MAX9718), $R_{IN} = R_F = 10k\Omega$ (MAX971_A), $T_A = +25^\circ C$. $C_{BIAS} = 0.1\mu F$, no load. Typical values are at $T_A = +25^\circ C$, unless otherwise noted.) (Note 1)

| PARAMETER | SYMBOL | CONDITIONS | MIN | TYP | MAX | UNITS |
|------------------------------------|------------|----------------------------------|-----|------|---------|------------|
| Gain Accuracy | | MAX971_B/MAX971_C/MAX971_D | | | ± 1 | % |
| Channel-to-Channel Gain Matching | | MAX9719B/MAX9719C/MAX9719D | | | ± 1 | % |
| Signal-to-Noise Ratio | SNR | $P_{OUT} = 1W$, $R_L = 8\Omega$ | | -104 | | dB |
| Thermal-Shutdown Threshold | | | | +160 | | $^\circ C$ |
| Thermal-Shutdown Hysteresis | | | | 15 | | $^\circ C$ |
| Maximum Capacitive Drive | C_{LOAD} | Bridge-tied capacitance | | 500 | | pF |
| Power-Up/Enable from Shutdown Time | t_{PU} | | | 10 | | ms |
| Shutdown Time | t_{SHDN} | | | 3.5 | | μs |
| Turn-Off Transient | V_{POP} | (Note 6) | | 50 | | mV |
| Crosstalk | | MAX9719, $f_{IN} = 1kHz$ | | -85 | | dB |

ELECTRICAL CHARACTERISTICS—3V Supply

($V_{CC} = 3V$, $GND = 0$, $\overline{SHDN}/\overline{SHDN} = V_{CC}$ (MAX9718/MAX9719), $\overline{SHDM} = GND$ (MAX9718), $R_{IN} = R_F = 10k\Omega$ (MAX971_A), $T_A = +25^\circ C$. $C_{BIAS} = 0.1\mu F$, no load. Typical values are at $T_A = +25^\circ C$, unless otherwise noted.) (Note 1)

| PARAMETER | SYMBOL | CONDITIONS | MIN | TYP | MAX | UNITS |
|--|------------|---|---------------------------------|----------------|------------------|-----------|
| Supply Current | I_{CC} | $V_{IN-} = V_{IN+} = V_{BIAS}$, $T_A = -40^\circ C$ to $+85^\circ C$, per amplifier (Note 2) | | 3.8 | 6.0 | mA |
| Shutdown Supply Current | I_{SHDN} | $\overline{SHDN} = \overline{SHDM} = \overline{SHDN} = GND$, per amplifier | | 0.1 | 1 | μA |
| \overline{SHDN} , SHDN, SHDM Threshold | V_{IH} | | $0.7 \times V_{CC}$ | | | V |
| | V_{IL} | | $0.3 \times V_{CC}$ | | | |
| Common-Mode Bias Voltage | V_{BIAS} | (Note 3) | $V_{CC}/2 - 5\%$ | $V_{CC}/2$ | $V_{CC}/2 + 5\%$ | V |
| Output Offset Voltage | V_{OS} | $V_{IN-} = V_{IN+} = V_{BIAS}$ | $A_V = 0dB$, MAX971_A/MAX971_B | ± 1 | ± 10 | mV |
| | | | $A_V = 3dB$, MAX971_C | ± 1 | ± 15 | |
| | | | $A_V = 6dB$, MAX971_D | ± 1 | ± 20 | |
| Common-Mode Input Voltage | V_{IC} | Inferred from CMRR test | $A_V = 0dB$, MAX971_B | 0.5 | $V_{CC} - 0.7$ | V |
| | | | $A_V = 3dB$, MAX971_C | 0.5 | $V_{CC} - 0.8$ | |
| | | | $A_V = 6dB$, MAX971_D | 0.5 | $V_{CC} - 1.0$ | |
| | | External gain, MAX971_A | 0.5 | $V_{CC} - 1.2$ | | |
| Input Impedance | R_{IN} | MAX971_B/MAX971_C/MAX971_D | 10 | 15 | 20 | $k\Omega$ |
| Common-Mode Rejection Ratio | CMRR | | -50 | -60 | | dB |
| | | $f_N = 1kHz$ | | -70 | | |
| Power-Supply Rejection Ratio | PSRR | $V_{IN-} = V_{IN+} = V_{BIAS}$, $V_{RIPPLE} = 200mV_{P-P}$, $R_L = 8\Omega$, $C_{BIAS} = 1\mu F$ | $f = 217Hz$ | -93 | | dB |
| | | | $f = 1kHz$ | -90 | | |

Low-Cost, Mono/Stereo, 1.4W Differential Audio Power Amplifiers

ELECTRICAL CHARACTERISTICS—3V Supply (continued)

($V_{CC} = 3V$, $GND = 0$, $SHDN/\overline{SHDN} = V_{CC}$ (MAX9718/MAX9719), $SHDM = GND$ (MAX9718), $R_{IN} = R_F = 10k\Omega$ (MAX971_A), $T_A = +25^\circ C$. $C_{BIAS} = 0.1\mu F$, no load. Typical values are at $T_A = +25^\circ C$, unless otherwise noted.) (Note 1)

| PARAMETER | SYMBOL | CONDITIONS | MIN | TYP | MAX | UNITS |
|--------------------------------------|------------|---|-----|-------|-----|------------|
| Output Power | P_{OUT} | $R_L = 8\Omega$, THD+N = 1%, $f_{IN} = 1kHz$ (Note 4) | | 475 | | mW |
| Total Harmonic Distortion Plus Noise | THD+N | $R_L = 8\Omega$, $f_{IN} = 1kHz$, $P_{OUT} = 0.25W$, $A_V = 6dB$ | | 0.003 | | % |
| Thermal-Shutdown Threshold | | | | +160 | | $^\circ C$ |
| Thermal-Shutdown Hysteresis | | | | 15 | | $^\circ C$ |
| Maximum Capacitive Drive | C_{LOAD} | Bridge-tied capacitance | | 500 | | pF |
| Power-Up/Enable from Shutdown Time | t_{PU} | | | 10 | | ms |
| Shutdown Time | t_{SHDN} | | | 3 | | μs |
| Turn-Off Transient | V_{POP} | (Note 6) | | 40 | | mV |
| Crosstalk | | MAX9719, $f_N = 1kHz$ | | -85 | | dB |

Note 1: All specifications are 100% tested at $T_A = +25^\circ C$. Specifications over temperature ($T_A = T_{MIN}$ to T_{MAX}) are guaranteed by design, not production tested.

Note 2: Quiescent power-supply current is specified and tested with no load. Quiescent power-supply current depends on the offset voltage when a practical load is connected to the amplifier. Guaranteed by design.

Note 3: Common-mode bias voltage is the voltage on BIAS and is nominally $V_{CC}/2$.

Note 4: Output power is specified by a combination of a functional output current test and characterization analysis.

Note 5: Measurement bandwidth for THD+N is 22Hz to 22kHz.

Note 6: Peak voltage measured at power-on, power-off, into or out of SHDN. Bandwidth defined by A-weighted filters, inputs at AC GND. V_{CC} rise and fall times greater than or equal to 1ms.

Typical Operating Characteristics

($V_{CC} = 5V$, $C_{BIAS} = 0.1\mu F$, THD+N measurement bandwidth = 22Hz to 22kHz, $T_A = +25^\circ C$, unless otherwise noted.)

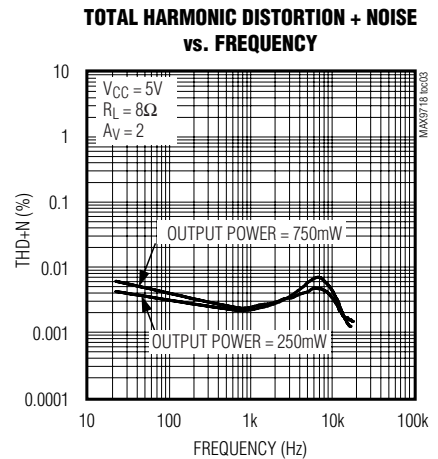
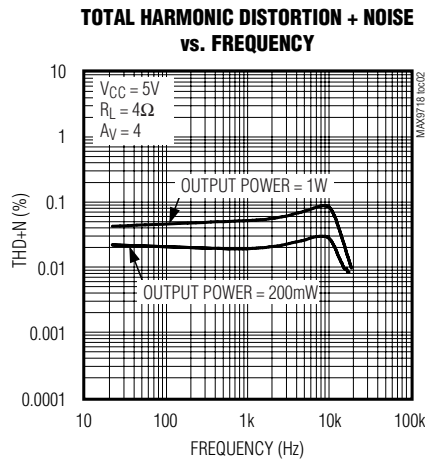
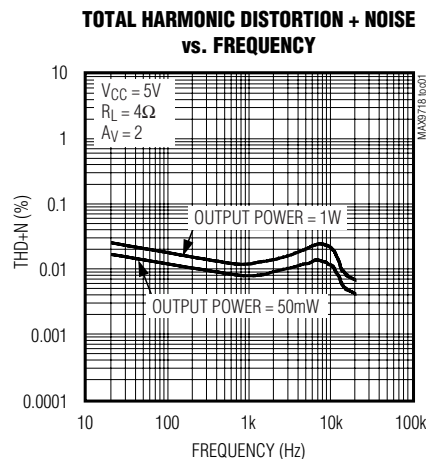

Low-Cost, Mono/Stereo, 1.4W Differential Audio Power Amplifiers

Typical Operating Characteristics (continued)

($V_{CC} = 5V$, $C_{BIAS} = 0.1\mu F$, THD+N measurement bandwidth = 22Hz to 22kHz, $T_A = +25^\circ C$, unless otherwise noted.)

MAX9718/MAX9719

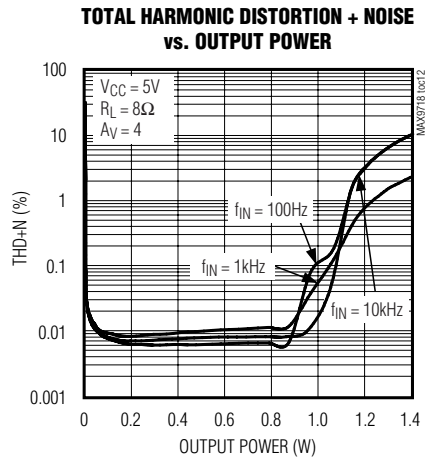
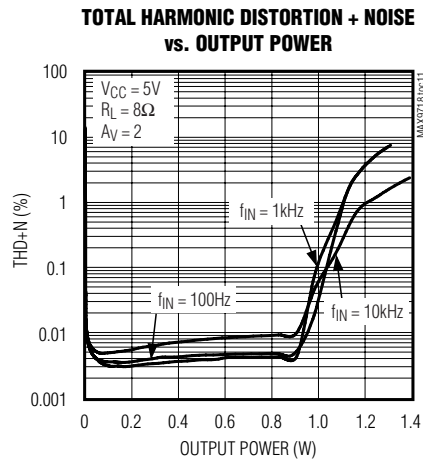
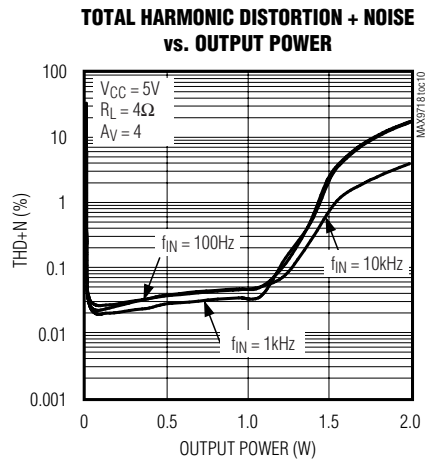
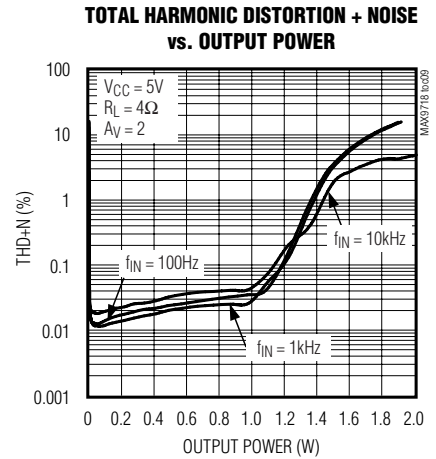
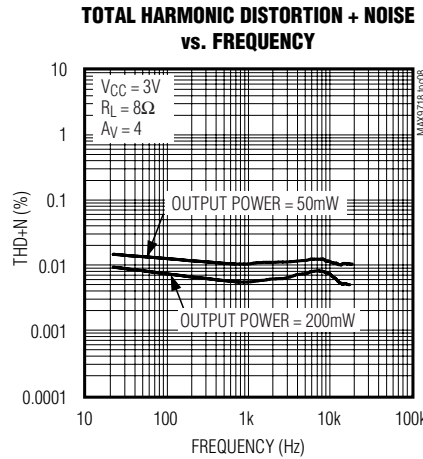
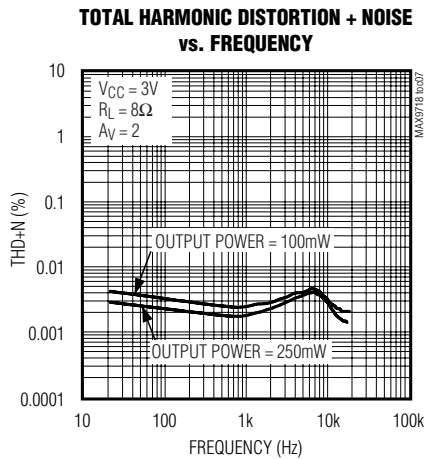
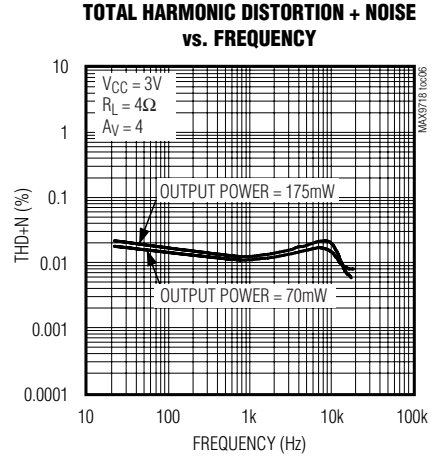
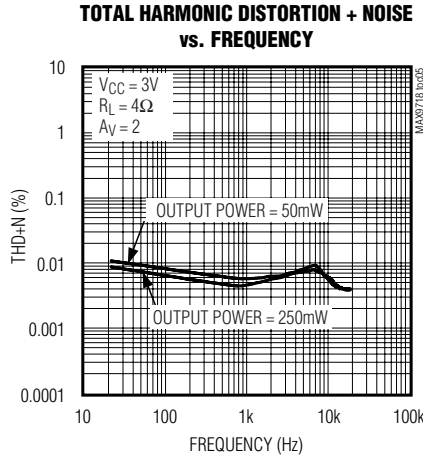
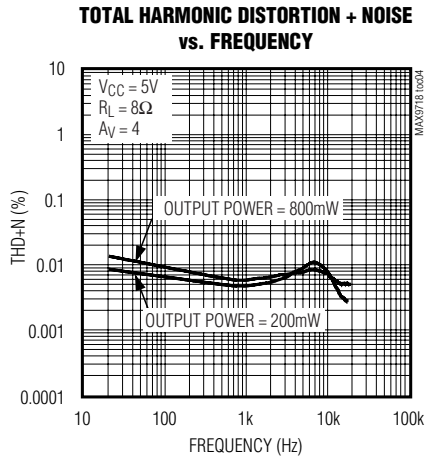

Low-Cost, Mono/Stereo, 1.4W Differential Audio Power Amplifiers

Typical Operating Characteristics (continued)

($V_{CC} = 5V$, $C_{BIAS} = 0.1\mu F$, THD+N measurement bandwidth = 22Hz to 22kHz, $T_A = +25^\circ C$, unless otherwise noted.)

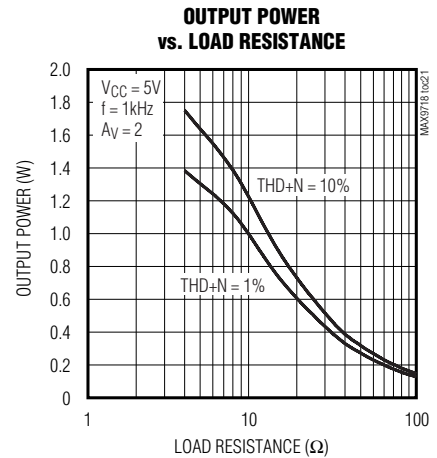
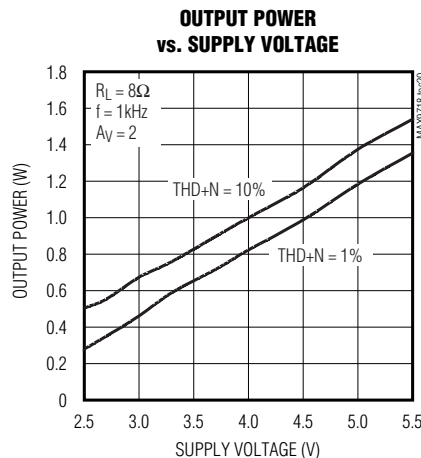
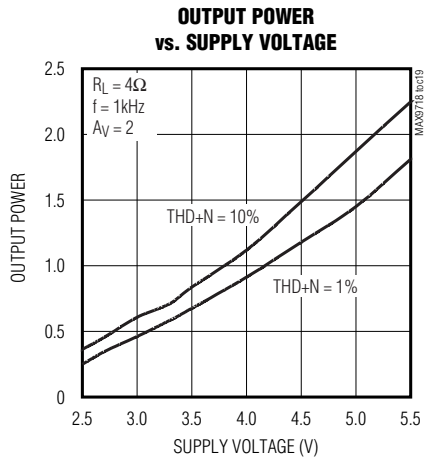
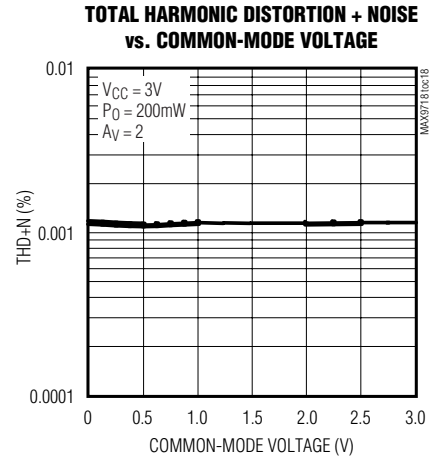
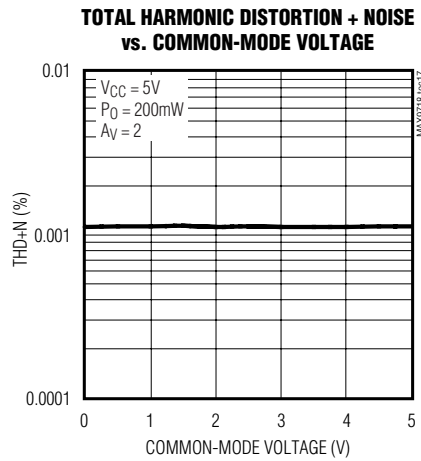
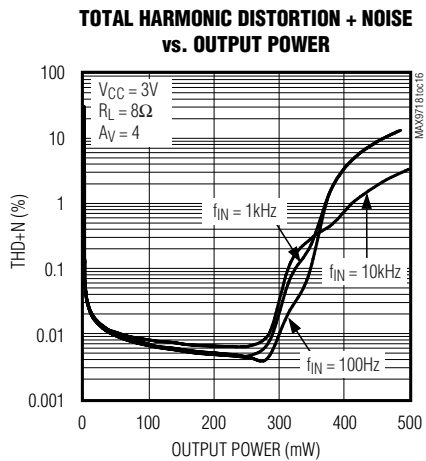
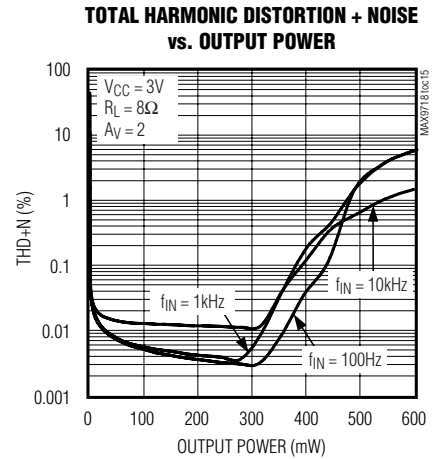
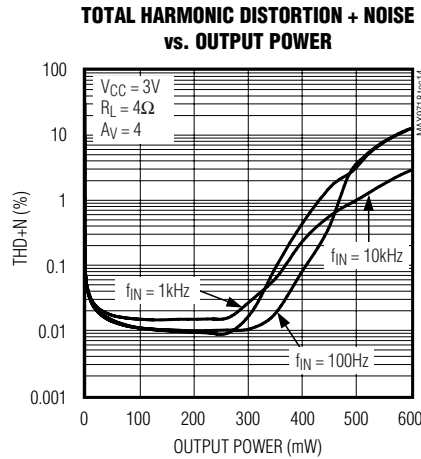
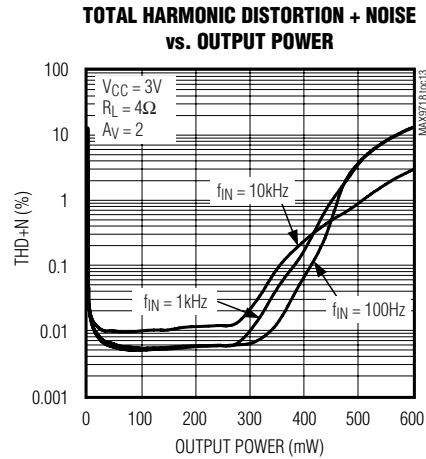

Low-Cost, Mono/Stereo, 1.4W Differential Audio Power Amplifiers

Typical Operating Characteristics (continued)

($V_{CC} = 5V$, $C_{BIAS} = 0.1\mu F$, THD+N measurement bandwidth = 22Hz to 22kHz, $T_A = +25^\circ C$, unless otherwise noted.)

MAX9718/MAX9719

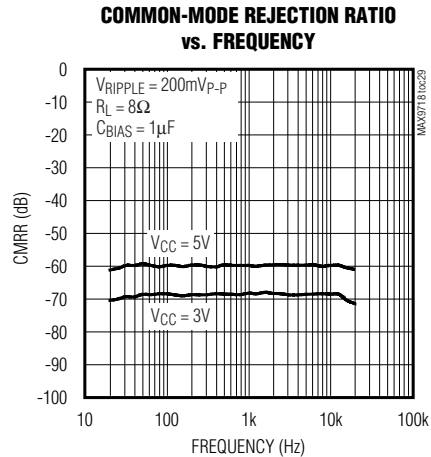
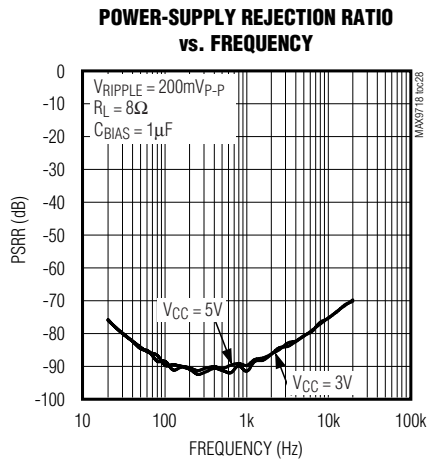
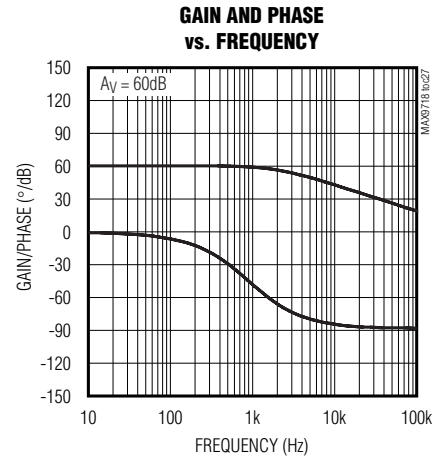
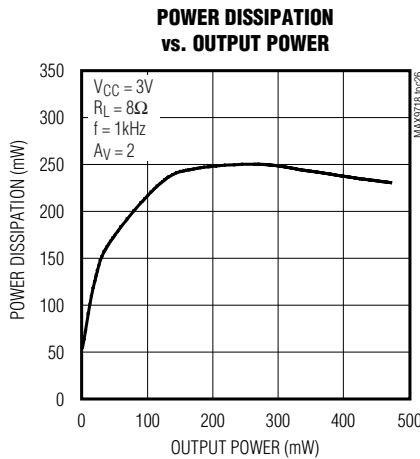
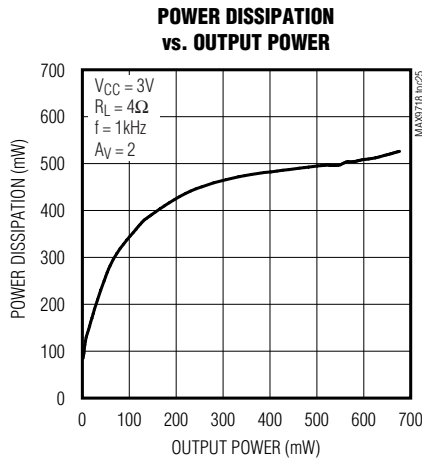
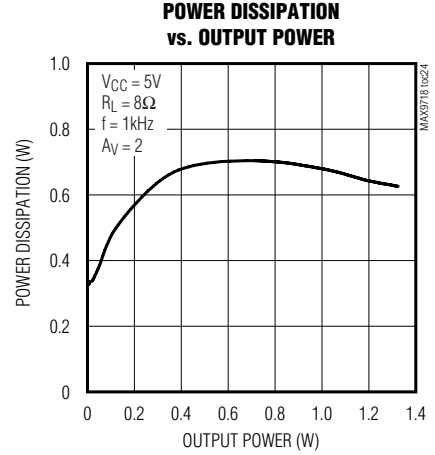
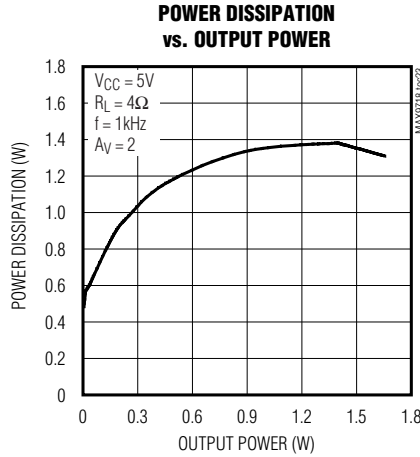
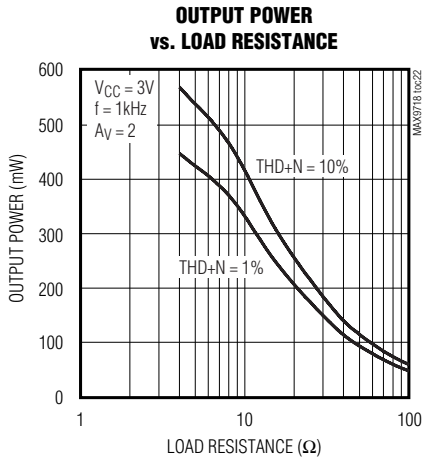

Low-Cost, Mono/Stereo, 1.4W Differential Audio Power Amplifiers

Typical Operating Characteristics (continued)

($V_{CC} = 5V$, $C_{BIAS} = 0.1\mu F$, THD+N measurement bandwidth = 22Hz to 22kHz, $T_A = +25^\circ C$, unless otherwise noted.)

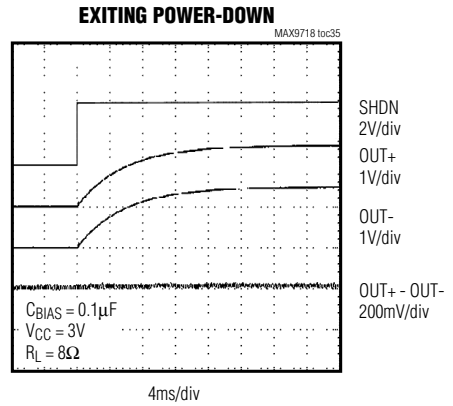
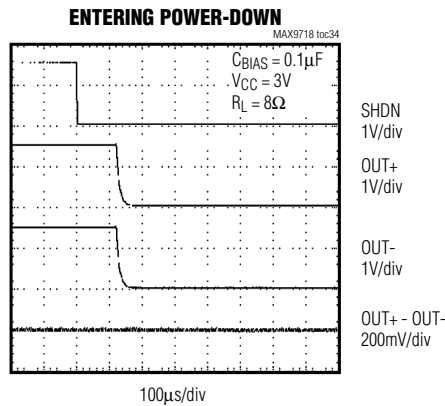
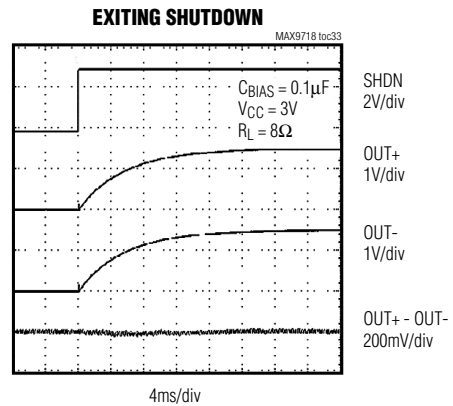
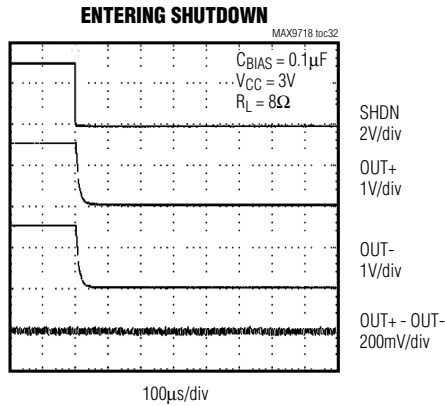
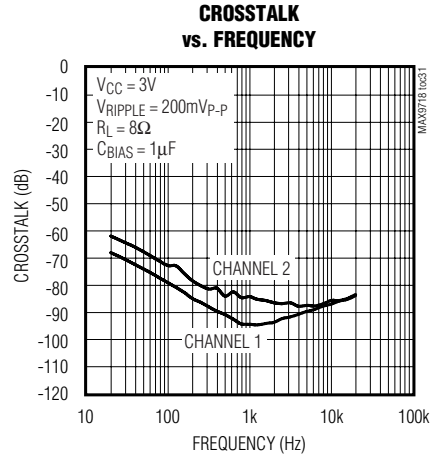
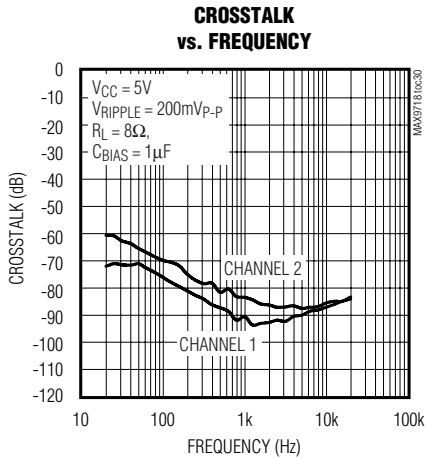

Low-Cost, Mono/Stereo, 1.4W Differential Audio Power Amplifiers

Typical Operating Characteristics (continued)

($V_{CC} = 5V$, $C_{BIAS} = 0.1\mu F$, THD+N measurement bandwidth = 22Hz to 22kHz, $T_A = +25^\circ C$, unless otherwise noted.)

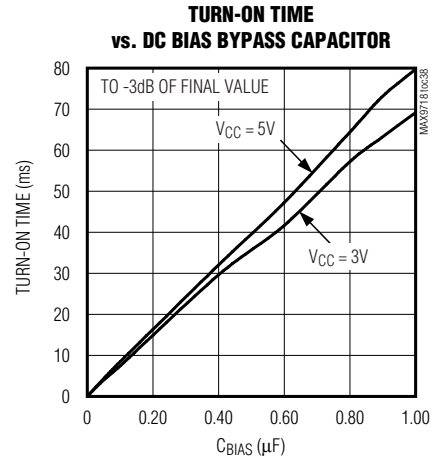
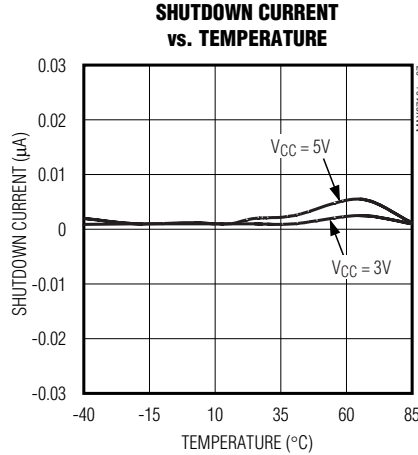
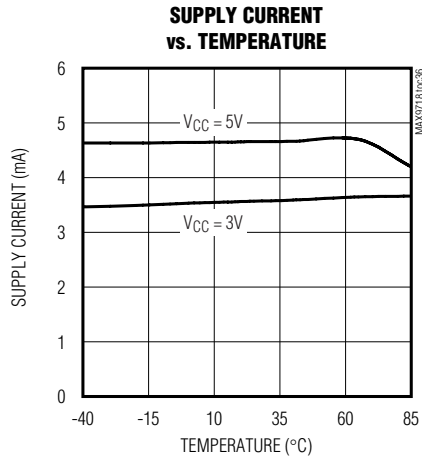

MAX9718/MAX9719

Pin Description

| PIN | | | | | NAME | FUNCTION |
|--------------------|------|----------|------------|----------|-------------------|---|
| MAX9718 | | MAX9719 | | | | |
| TDFN/ μ MAX | UCSP | TQFN | UCSP | TSSOP | | |
| 1 | C2 | — | — | — | SHDN | Shutdown Input. The polarity of SHDN is dependent on the state of SHDM. |
| — | — | 9 | B3 | 11 | \overline{SHDN} | Shutdown Input. Active-low shutdown input. |
| 2 | C1 | — | — | — | IN- | Inverting Input |
| 3 | B2 | — | — | — | SHDM | Shutdown-Mode Polarity Input. SHDM controls the polarity of SHDN. Connect SHDM high for an active-high SHDN input. Connect SHDM low for an active-low SHDN input (see Table 1). |
| 4 | A1 | — | — | — | IN+ | Noninverting Input |
| 5 | A2 | 5 | B2 | 7 | BIAS | DC Bias Bypass |
| 6 | A3 | — | — | — | OUT- | Bridge Amplifier Negative Output |
| 7 | B3 | 1, 6, 11 | A2, C2, C4 | 3, 8, 13 | GND | Ground |
| 8 | — | 13 | — | 15 | N.C. | No Connection. Not internally connected. |
| 9 | B1 | 8, 14 | A4, D3 | 16, 10 | VCC | Power Supply |
| 10 | C3 | — | — | — | OUT+ | Bridge Amplifier Positive Output |
| — | — | 2 | C1 | 4 | INR+ | Right-Channel Noninverting Input |
| — | — | 3 | B1 | 5 | INL- | Left-Channel Inverting Input |
| — | — | 4 | A1 | 6 | INL+ | Left-Channel Noninverting Input |
| — | — | 7 | A3 | 9 | OUTL+ | Left-Channel Bridge Amplifier Positive Output |
| — | — | 10 | B4 | 12 | OUTL- | Left-Channel Bridge Amplifier Negative Output |

Low-Cost, Mono/Stereo, 1.4W Differential Audio Power Amplifiers

Pin Description (continued)

| PIN | | | | | NAME | FUNCTION |
|---------------|------|---------|------|-------|-------|--|
| MAX9718 | | MAX9719 | | | | |
| TDFN/ μMAX | UCSP | TQFN | UCSP | TSSOP | | |
| — | — | 12 | D4 | 14 | OUTR+ | Right-Channel Bridge Amplifier Positive Output |
| — | — | 15 | D2 | 1 | OUTR- | Right-Channel Bridge Amplifier Negative Output |
| — | — | 16 | D1 | 2 | INR- | Right-Channel Inverting Input |
| EP | — | EP | — | EP | EP | Exposed Pad. Connect EP to GND. |

Detailed Description

The MAX9718/MAX9719 are 1.4W BTL speaker amplifiers. The MAX9718 is a mono speaker amplifier, while the MAX9719 is a stereo speaker amplifier. Both devices feature a low-power shutdown mode, and industry-leading click-and-pop suppression. The MAX9718 features a two-input shutdown scheme to configure shutdown for active high or active low. These devices consist of high output-current audio amps configured as BTL amplifiers (see the *Functional Diagrams*). Both adjustable and fixed gain (0dB, 3dB, 6dB) versions are available.

BIAS

These devices operate from a single 2.7V to 5.5V supply and feature an internally generated, common-mode bias voltage of $V_{CC}/2$ referenced to ground. BIAS provides both click-and-pop suppression and sets the DC bias level for the audio outputs. Choose the value of the bypass capacitor as described in the *BIAS Capacitor* section. Do not connect external loads to BIAS as this can affect the overall performance.

Shutdown Mode

The MAX9718/MAX9719 feature a 100nA low-power shutdown mode that reduces quiescent current consumption. Entering shutdown disables the device's bias circuitry, the amplifier outputs go high impedance, and BIAS is driven to GND. The MAX9718 SHDM input controls the polarity of SHDN. Drive SHDM high for an active-high SHDN input. Drive SHDM low for an active-low SHDN input (see Table 1). The MAX9719 features an active-low shutdown input, $\overline{\text{SHDN}}$.

Click-and-Pop Suppression

The MAX9718/MAX9719 feature Maxim's industry-leading click-and-pop suppression circuitry. During startup, the amplifier common-mode bias voltage ramps to the DC bias point. When entering shutdown, the amplifier outputs are high impedance to 100kΩ between both outputs. This scheme minimizes the energy present in the audio band.

Table 1. Shutdown Mode Selection (MAX9718 Only)

| SHDM | SHDN | OPERATIONAL MODE |
|------|------|------------------|
| 0 | 0 | Shutdown |
| 0 | 1 | Normal operation |
| 1 | 0 | Normal operation |
| 1 | 1 | Shutdown |

Applications Information

BTL Amplifier

The MAX9718/MAX9719 are designed to drive a load differentially, a configuration referred to as bridge-tied load or BTL. The BTL configuration (Figure 1) offers advantages over the single-ended configuration, where one side of the load is connected to ground. Driving the load differentially doubles the output voltage compared to a single-ended amplifier under similar conditions.

Substituting $2 \times V_{\text{OUT(P-P)}}$ for $V_{\text{OUT(P-P)}}$ into the following equations yields four times the output power due to doubling of the output voltage:

$$V_{\text{RMS}} = \frac{V_{\text{OUT(P-P)}}}{2\sqrt{2}}$$

$$P_{\text{OUT}} = \frac{V_{\text{RMS}}^2}{R_L}$$

Since the differential outputs are biased at midsupply, there is no net DC voltage across the load. This eliminates the need for DC-blocking capacitors required for single-ended amplifiers. These capacitors can be large, expensive, consume board space, and degrade low-frequency performance.

Low-Cost, Mono/Stereo, 1.4W Differential Audio Power Amplifiers

MAX9718/MAX9719

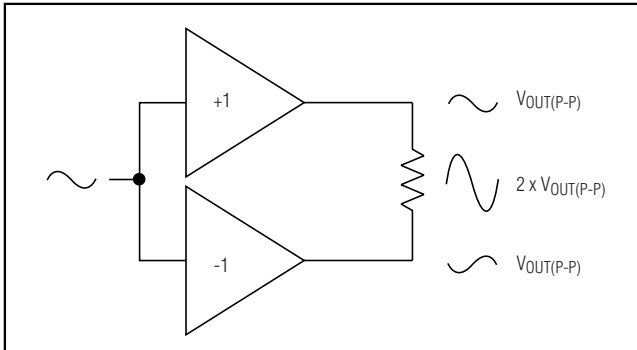

Figure 1. Bridge-Tied Load Configuration

Power Dissipation and Heat Sinking

Under normal operating conditions, the MAX9718/MAX9719 dissipate a significant amount of power. The maximum power dissipation for each package is given in the *Absolute Maximum Ratings* section under Continuous Power Dissipation or can be calculated by the following equation:

$$P_{D(MAX)} = \frac{T_{J(MAX)} - T_A}{\theta_{JA}}$$

where $T_{J(MAX)}$ is +150°C, T_A is the ambient temperature, and θ_{JA} is the reciprocal of the derating factor in °C/W as specified in the *Absolute Maximum Ratings* section. For example, θ_{JA} of the TQFN package is +59.2°C/W.

The increase in power delivered by the BTL configuration directly results in an increase in internal power dissipation over the single-ended configuration. The maximum internal power dissipation for a given V_{CC} and load is given by the following equation:

$$P_{D(MAX)} = \frac{2V_{CC}^2}{\pi^2 R_L}$$

If the internal power dissipation for a given application exceeds the maximum allowed for a given package, reduce power dissipation by increasing the ground plane heat-sinking capability and the size of the traces to the device (see the *Layout and Grounding* section). Other methods for reducing power dissipation are to reduce V_{CC} , increase load impedance, decrease ambient temperature, reduce gain, or reduce input signal.

Thermal-overload protection limits total power dissipation in the MAX9718/MAX9719. When the junction temperature exceeds +160°C, the thermal protection circuitry disables the amplifier output stage. The amplifiers are enabled once the junction temperature cools

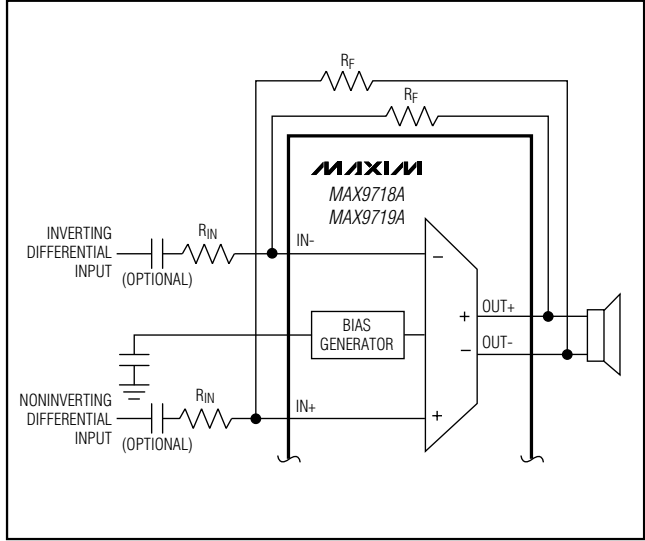

Figure 2. Setting the MAX9718A/MAX9719A Gain

by 15°C. A pulsing output under continuous thermal overload results as the device heats and cools.

For optimum power dissipation and heat sinking, connect the exposed pad found on the μ MAX, TDFN, TQFN, and TSSOP packages to a large ground plane.

Fixed Differential Gain

The MAX9718B, MAX9718C, MAX9718D, MAX9719B, MAX9719C, and MAX9719D feature internally fixed gains (see the *Selector Guide*). This simplifies design, decreases required footprint size, and eliminates external gain-setting resistors. Resistors R1 and R2 shown in the *Typical Operating Circuit* are used to achieve each fixed gain.

Adjustable Differential Gain Gain-Setting Resistors

External feedback resistors set the gain of the MAX9718A and MAX9719A. Resistors R_F and R_{IN} (Figure 2) set the gain of the amplifier as follows:

$$A_V = \frac{R_F}{R_{IN}}$$

where A_V is the desired voltage gain. Hence, an R_{IN} of 10k Ω and an R_F of 20k Ω yields a gain of 2V/V, or 6dB.

R_F can be either fixed or variable, allowing the use of a digitally controlled potentiometer to alter the gain under software control.

Low-Cost, Mono/Stereo, 1.4W Differential Audio Power Amplifiers

Input Filter

The fully differential amplifier inputs can be biased at voltages other than midsupply. The common-mode feedback circuit adjusts for input bias, ensuring the outputs are still biased at midsupply. Input capacitors are not required as long as the common-mode input voltage is within the specified range listed in the *Electrical Characteristics* table.

If input capacitors are used, input capacitor C_{IN} , in conjunction with R_{IN} , forms a highpass filter that removes the DC bias from an incoming signal. The AC-coupling capacitor allows the amplifier to bias the signal to an optimum DC level. Assuming zero-source impedance, the -3dB point of the highpass filter is given by:

$$f_{-3dB} = \frac{1}{2\pi R_{IN} C_{IN}}$$

Setting f_{-3dB} too high affects the low-frequency response of the amplifier. Use capacitors with dielectrics that have low-voltage coefficients, such as tantalum or aluminum electrolytic. Capacitors with high-voltage coefficients, such as ceramics, can increase distortion at low frequencies.

BIAS Capacitor

BIAS is the output of the internally generated $V_{CC}/2$ bias voltage. The BIAS bypass capacitor, C_{BIAS} , improves PSRR and THD+N by reducing power supply and other noise sources at the common-mode bias node, and also generates the clickless/popless startup DC bias waveform for the speaker amplifiers. Bypass BIAS with a 0.1 μ F capacitor to GND. Larger values of C_{BIAS} (up to 1 μ F) improve PSRR, but slow down t_{ON}/t_{OFF} times. A 1 μ F C_{BIAS} capacitor slows turn-on and turn-off times by 10 and improves PSRR by 20dB (at 1kHz). Do not connect external loads to BIAS.

Supply Bypassing

Proper power-supply bypassing ensures low-noise, low-distortion performance. Connect a 1 μ F ceramic capacitor from V_{CC} to GND. Add additional bulk capacitance as required by the application. Locate the bypass capacitor as close to the device as possible.

Layout and Grounding

Good PC board layout is essential for optimizing performance. Use large traces for the power-supply inputs and amplifier outputs to minimize losses due to parasitic trace resistance and route heat away from the device. Good grounding improves audio performance, minimizes crosstalk between channels, and prevents any digital switching noise from coupling into the audio signal.

The MAX9718/MAX9719 TDFN, TQFN, TSSOP, and μ MAX packages feature exposed thermal pads on their undersides. This pad lowers the thermal resistance of the package by providing a direct-heat conduction path from the die to the PC board. Connect the exposed pad to the ground plane using multiple vias, if required.

UCSP Applications Information

For the latest application details on UCSP construction, dimensions, tape carrier information, PC board techniques, bump-pad layout, and recommended reflow temperature profile, as well as the latest information on reliability testing results, refer to the Application Note: *UCSP—A Wafer-Level Chip-Scale Package* available on Maxim's website at www.maxim-ic.com/ucsp.

Selector Guide

| PART | MONO | STEREO | GAIN (dB) | SELECTABLE SHUTDOWN POLARITY |
|----------|------|--------|------------|------------------------------|
| MAX9718A | √ | — | Adjustable | √ |
| MAX9718B | √ | — | 0 | √ |
| MAX9718C | √ | — | 3 | √ |
| MAX9718D | √ | — | 6 | √ |
| MAX9719A | — | √ | Adjustable | — |
| MAX9719B | — | √ | 0 | — |
| MAX9719C | — | √ | 3 | — |
| MAX9719D | — | √ | 6 | — |

Low-Cost, Mono/Stereo, 1.4W Differential Audio Power Amplifiers

Ordering Information (continued)

| PART | TEMP RANGE | PIN-PACKAGE | GAIN (dB) |
|----------------------|----------------|------------------|-----------|
| MAX9718BEBL-T | -40°C to +85°C | 3 x 3 UCSP | 0 |
| MAX9718BETB | -40°C to +85°C | 10 TDFN-EP* | 0 |
| MAX9718BEUB | -40°C to +85°C | 10 μ MAX-EP* | 0 |
| MAX9718CEBL-T | -40°C to +85°C | 3 x 3 UCSP | 3 |
| MAX9718CETB | -40°C to +85°C | 10 TDFN-EP* | 3 |
| MAX9718CEUB | -40°C to +85°C | 10 μ MAX-EP* | 3 |
| MAX9718DEBL-T | -40°C to +85°C | 3 x 3 UCSP | 6 |
| MAX9718DETB | -40°C to +85°C | 10 TDFN-EP* | 6 |
| MAX9718DEUB | -40°C to +85°C | 10 μ MAX-EP* | 6 |
| MAX9719AEBE-T | -40°C to +85°C | 4 x 4 UCSP | Adj |
| MAX9719AETE | -40°C to +85°C | 16 TQFN-EP* | Adj |
| MAX9719AEAE | -40°C to +85°C | 16 TSSOP-EP* | Adj |
| MAX9719BEBE-T | -40°C to +85°C | 4 x 4 UCSP | 0 |
| MAX9719BETE | -40°C to +85°C | 16 TQFN-EP* | 0 |
| MAX9719BEAE | -40°C to +85°C | 16 TSSOP-EP* | 0 |
| MAX9719CEBE-T | -40°C to +85°C | 4 x 4 UCSP | 3 |
| MAX9719CETE | -40°C to +85°C | 16 TQFN-EP* | 3 |
| MAX9719CEAE | -40°C to +85°C | 16 TSSOP-EP* | 3 |
| MAX9719DEBE-T | -40°C to +85°C | 4 x 4 UCSP | 6 |
| MAX9719DETE | -40°C to +85°C | 16 TQFN-EP* | 6 |
| MAX9719DEAE | -40°C to +85°C | 16 TSSOP-EP* | 6 |

*EP = Exposed paddle.

UCSP Marking Information:



■: A1 Bump indicator

AAA: Product code

XXX: Lot code

Chip Information

MAX9718 TRANSISTOR COUNT: 2359

MAX9719 TRANSISTOR COUNT: 4447

PROCESS: BICMOS

MAX9718/MAX9719

Low-Cost, Mono/Stereo, 1.4W Differential Audio Power Amplifiers

System Diagram

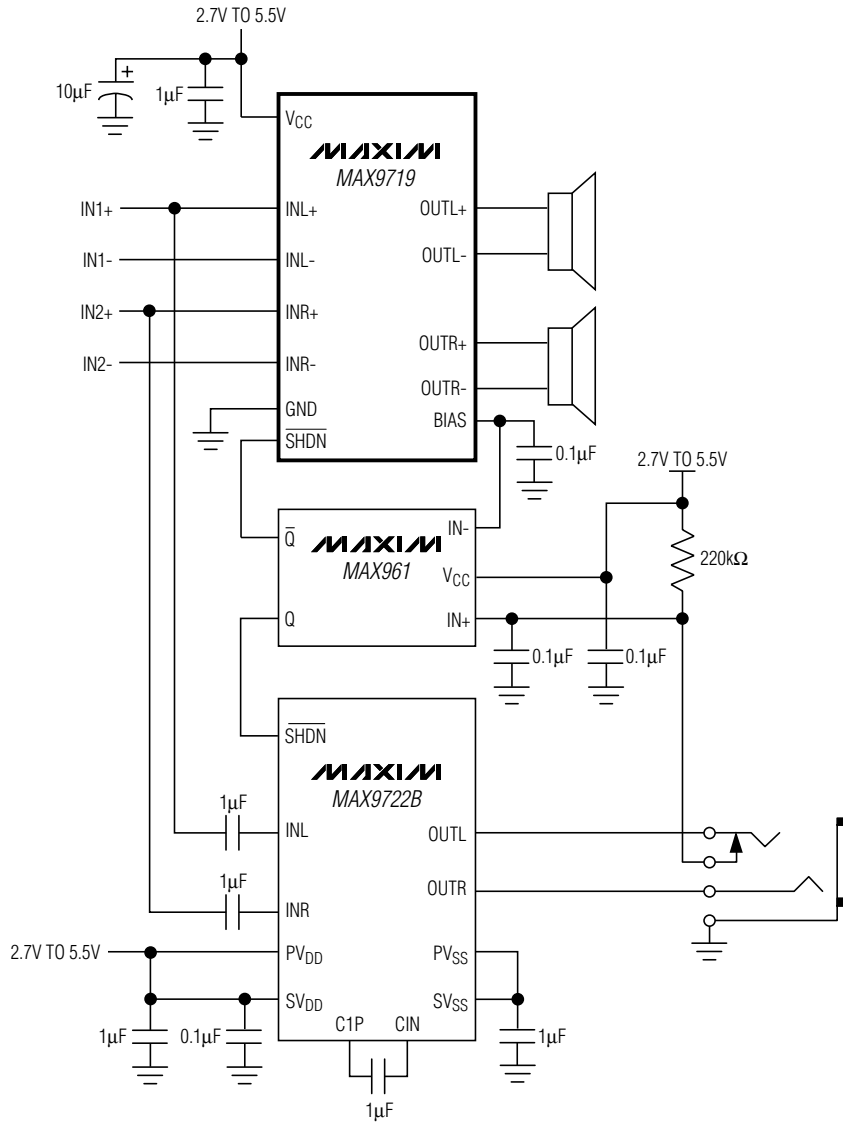

AUTOMATIC HEADPHONE DETECTION AND SPEAKER DISABLE CIRCUIT

Low-Cost, Mono/Stereo, 1.4W Differential Audio Power Amplifiers

Functional Diagrams

MAX9718/MAX9719

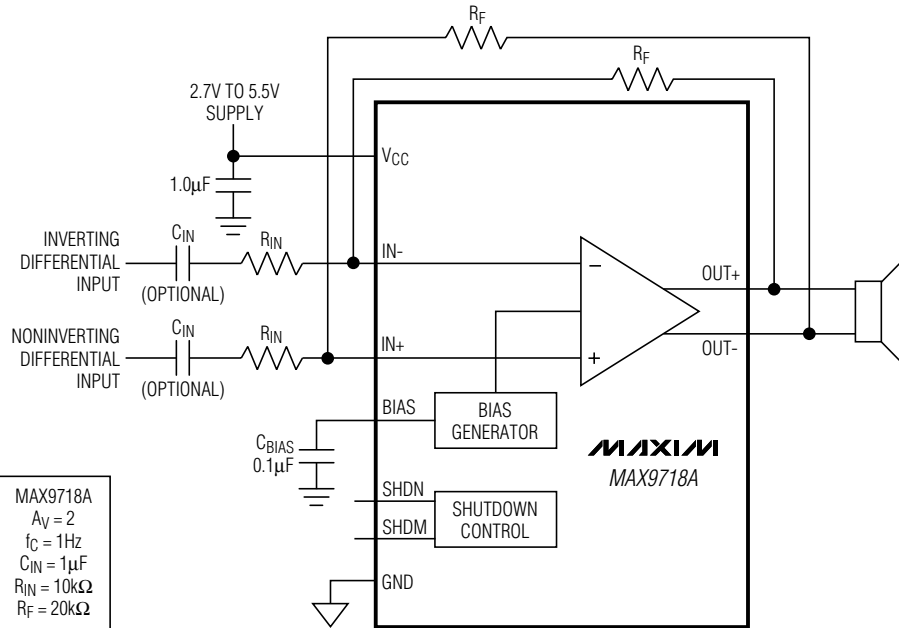
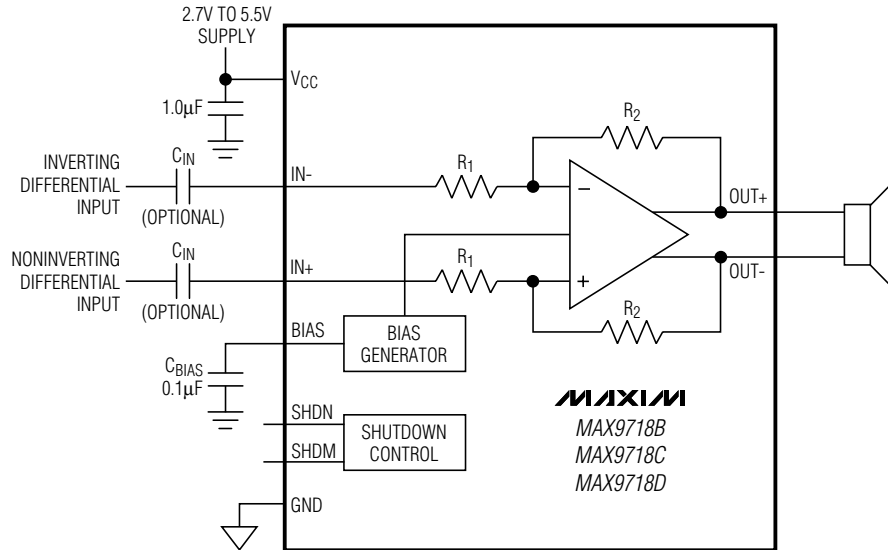

MAX9718A
 $A_V = 2$
 $f_c = 1\text{Hz}$
 $C_{IN} = 1\mu\text{F}$
 $R_{IN} = 10\text{k}\Omega$
 $R_F = 20\text{k}\Omega$

Low-Cost, Mono/Stereo, 1.4W Differential Audio Power Amplifiers

Functional Diagrams (continued)

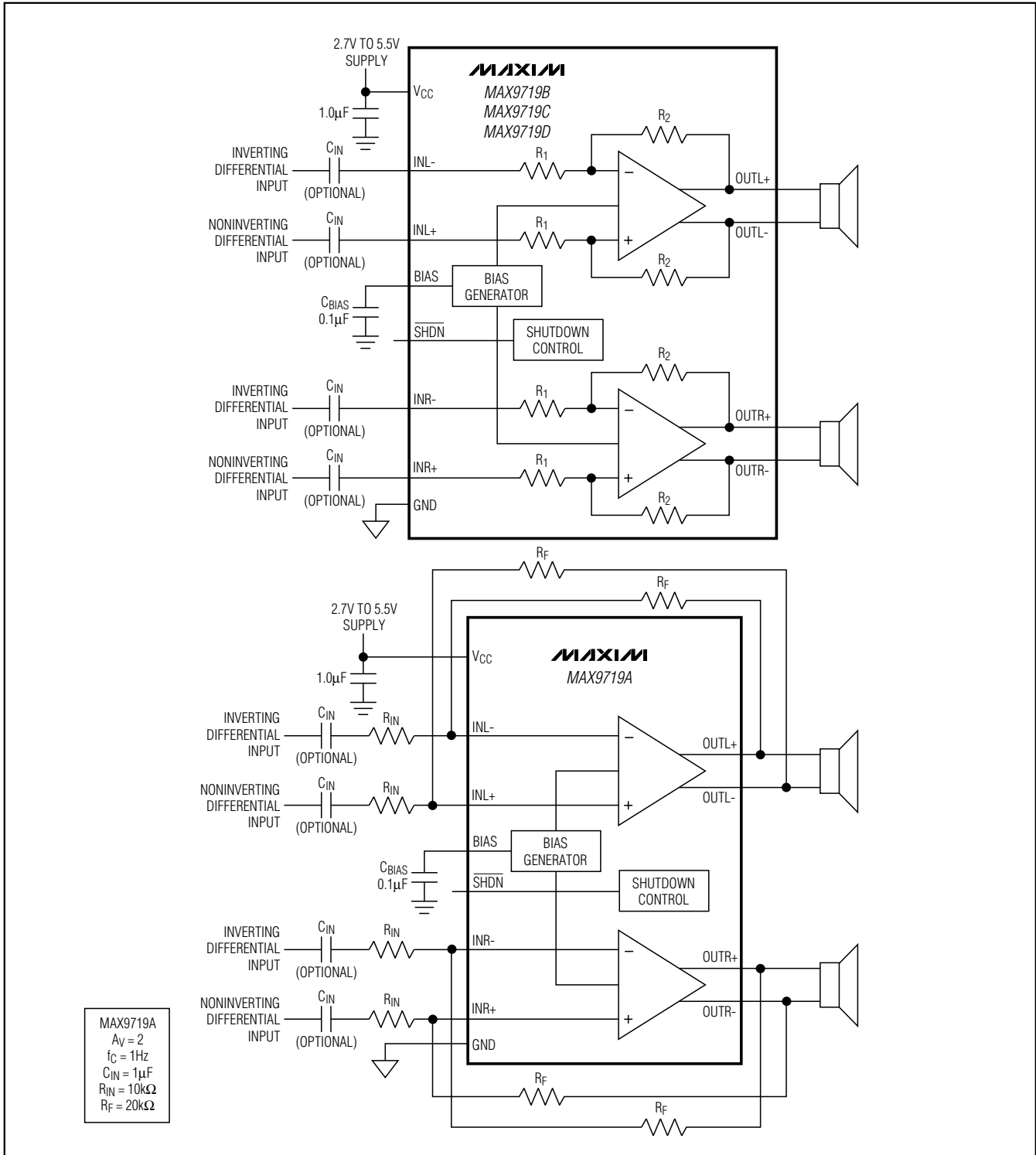

Low-Cost, Mono/Stereo, 1.4W Differential Audio Power Amplifiers

Pin Configurations

MAX9718/MAX9719

TOP VIEW

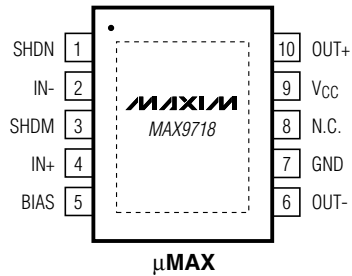

TOP VIEW
(BUMPS ON BOTTOM)

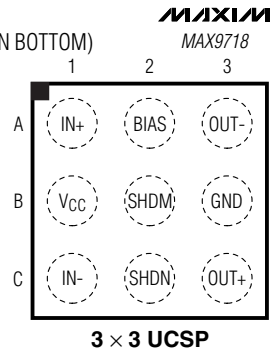

TOP VIEW

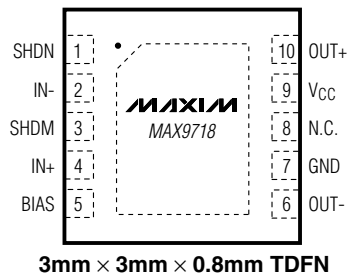

TOP VIEW
(BUMPS ON BOTTOM)

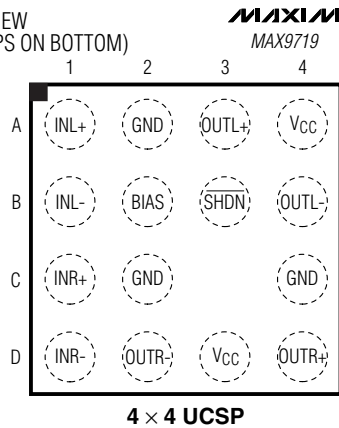

TOP VIEW

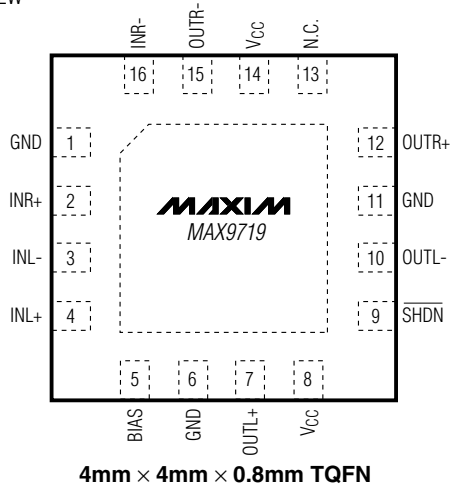

TOP VIEW

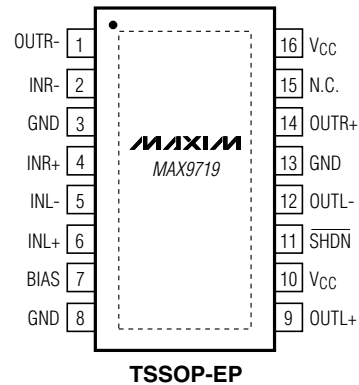

Low-Cost, Mono/Stereo, 1.4W Differential Audio Power Amplifiers

Package Information

(The package drawing(s) in this data sheet may not reflect the most current specifications. For the latest package outline information go to www.maxim-ic.com/packages.)

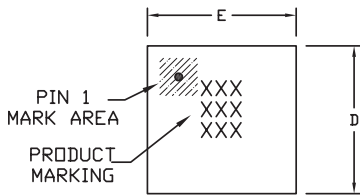

TOP VIEW

| COMMON DIMENSIONS | |
|-------------------|----------------|
| A | 0.62±0.05-0.08 |
| A1 | 0.29±0.02 |
| A2 | 0.33 REF. |
| b | ∅0.35±0.03 |
| D1 | 1.00 BASIC |
| E1 | 1.00 BASIC |
| e | 0.50 BASIC |
| SD | 0.00 BASIC |
| SE | 0.00 BASIC |

| PKG. CODE | VARIABLE DIMENSIONS | | DEPOPULATED SOLDER BALLS |
|-----------|---------------------|-----------|--------------------------|
| | D | E | |
| B9-1 | 1.52±0.05 | 1.52±0.05 | NONE |
| B9-2 | 1.52±0.05 | 1.52±0.05 | B2 |
| B9-3 | 1.52±0.05 | 1.52±0.05 | B1, B2, B3 |
| B9-4 | 1.60±0.05 | 1.60±0.05 | NONE |
| B9-5 | 1.60±0.05 | 1.60±0.05 | B2 |
| B9-6 | 1.60±0.05 | 1.60±0.05 | B1, B2, B3 |

- NOTES:
 1. ALL DIMENSIONS ARE IN MILLIMETERS.
 2. PRODUCT MARKING: NUMBER OF CHARACTERS AND LINES VARY PER PRODUCT.

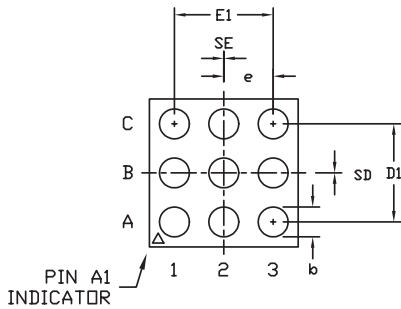

BOTTOM VIEW

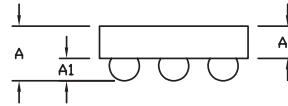

SIDE VIEW

| | | |
|-------------------------------------|---------------------------------|---------------|
| | | |
| PROPRIETARY INFORMATION | | |
| TITLE: PACKAGE OUTLINE, 3x3 UCSP | | |
| APPROVAL | DOCUMENT CONTROL NO. 21-0093 | REV. I 1/1 |

Low-Cost, Mono/Stereo, 1.4W Differential Audio Power Amplifiers

Package Information (continued)

(The package drawing(s) in this data sheet may not reflect the most current specifications. For the latest package outline information go to www.maxim-ic.com/packages.)

MAX9718/MAX9719

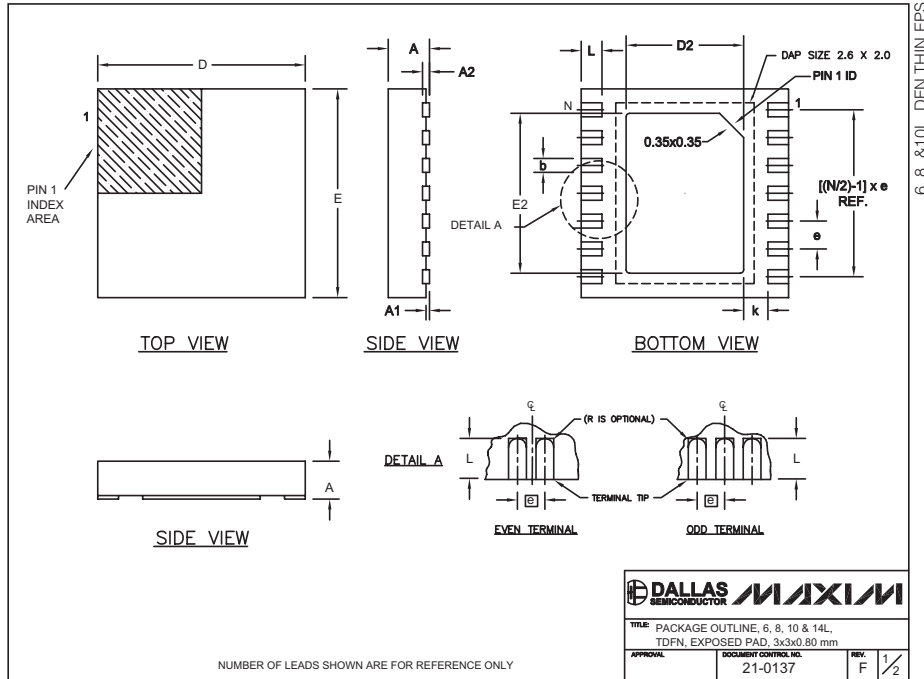

| COMMON DIMENSIONS | | | | | | | |
|-------------------|-----------|------|--|--|--|--|--|
| SYMBOL | MIN. | MAX. | | | | | |
| A | 0.70 | 0.80 | | | | | |
| D | 2.90 | 3.10 | | | | | |
| E | 2.90 | 3.10 | | | | | |
| A1 | 0.00 | 0.05 | | | | | |
| L | 0.20 | 0.40 | | | | | |
| k | 0.25 MIN. | | | | | | |
| A2 | 0.20 REF. | | | | | | |

| PACKAGE VARIATIONS | | | | | | | |
|--------------------|----|-----------|-----------|----------|----------------|-----------|---------------|
| PKG. CODE | N | D2 | E2 | e | JEDEC SPEC | b | [(N/2)-1] x e |
| T633-1 | 6 | 1.50±0.10 | 2.30±0.10 | 0.95 BSC | MO229 / WEEA | 0.40±0.05 | 1.90 REF |
| T833-1 | 8 | 1.50±0.10 | 2.30±0.10 | 0.65 BSC | MO229 / WEEC | 0.30±0.05 | 1.95 REF |
| T1033-1 | 10 | 1.50±0.10 | 2.30±0.10 | 0.50 BSC | MO229 / WEED-3 | 0.25±0.05 | 2.00 REF |
| T1433-1 | 14 | 1.70±0.10 | 2.30±0.10 | 0.40 BSC | ---- | 0.20±0.03 | 2.40 REF |
| T1433-2 | 14 | 1.70±0.10 | 2.30±0.10 | 0.40 BSC | ---- | 0.20±0.03 | 2.40 REF |

NOTES:

1. ALL DIMENSIONS ARE IN mm, ANGLES IN DEGREES.
2. COPLANARITY SHALL NOT EXCEED 0.08 mm.
3. WARPAGE SHALL NOT EXCEED 0.10 mm.
4. PACKAGE LENGTH/PACKAGE WIDTH ARE CONSIDERED AS SPECIAL CHARACTERISTIC(S).
5. DRAWING CONFORMS TO JEDEC MO229, EXCEPT DIMENSIONS "D2" AND "E2", AND T1433-1 & T1433-2.
6. "N" IS THE TOTAL NUMBER OF LEADS.

| | | | |
|---|----------------------|------|-----|
| DALLAS SEMICONDUCTOR MAXIM | | | |
| TITLE PACKAGE OUTLINE, 6, 8, 10 & 14L, TDFN, EXPOSED PAD, 3x3x0.80 mm | | | |
| APPROVAL | DOCUMENT CONTROL NO. | REV. | 2/2 |
| | 21-0137 | F | |

Low-Cost, Mono/Stereo, 1.4W Differential Audio Power Amplifiers

Package Information (continued)

(The package drawing(s) in this data sheet may not reflect the most current specifications. For the latest package outline information go to www.maxim-ic.com/packages.)

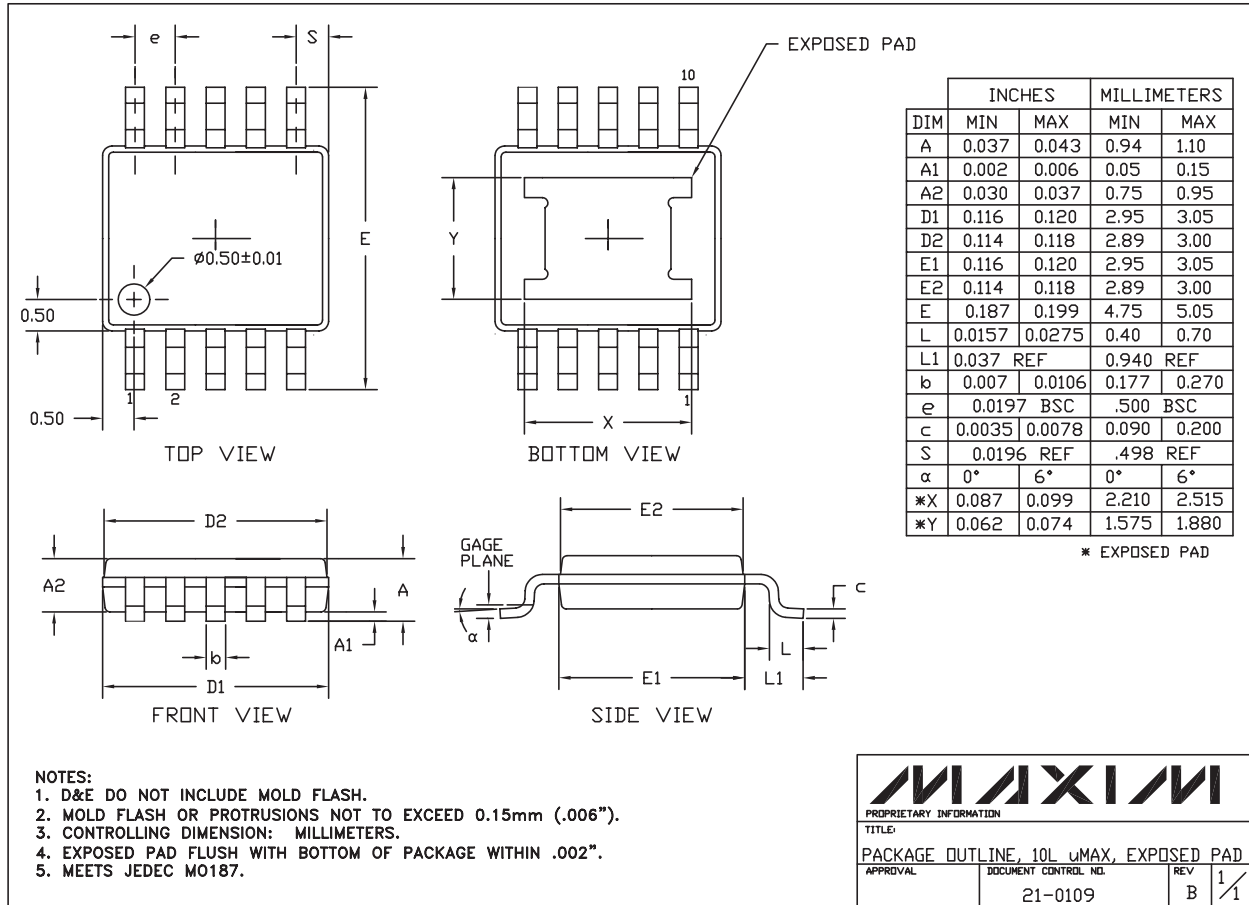

10L_UMAX, EXPPADS.EPS

Low-Cost, Mono/Stereo, 1.4W Differential Audio Power Amplifiers

Package Information (continued)

(The package drawing(s) in this data sheet may not reflect the most current specifications. For the latest package outline information go to www.maxim-ic.com/packages.)

MAX9718/MAX9719

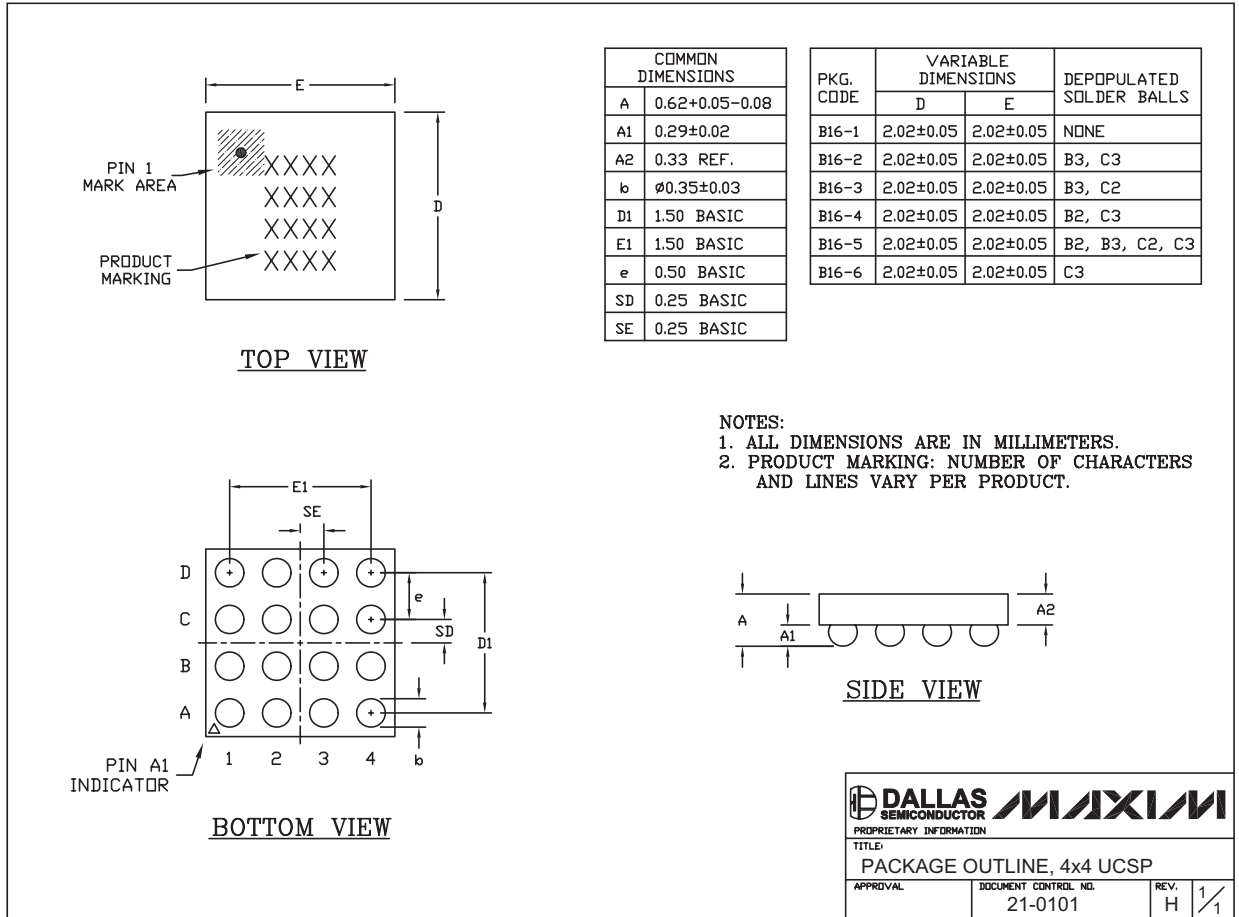

161UCSP.EPS

Low-Cost, Mono/Stereo, 1.4W Differential Audio Power Amplifiers

Package Information (continued)

(The package drawing(s) in this data sheet may not reflect the most current specifications. For the latest package outline information go to www.maxim-ic.com/packages.)

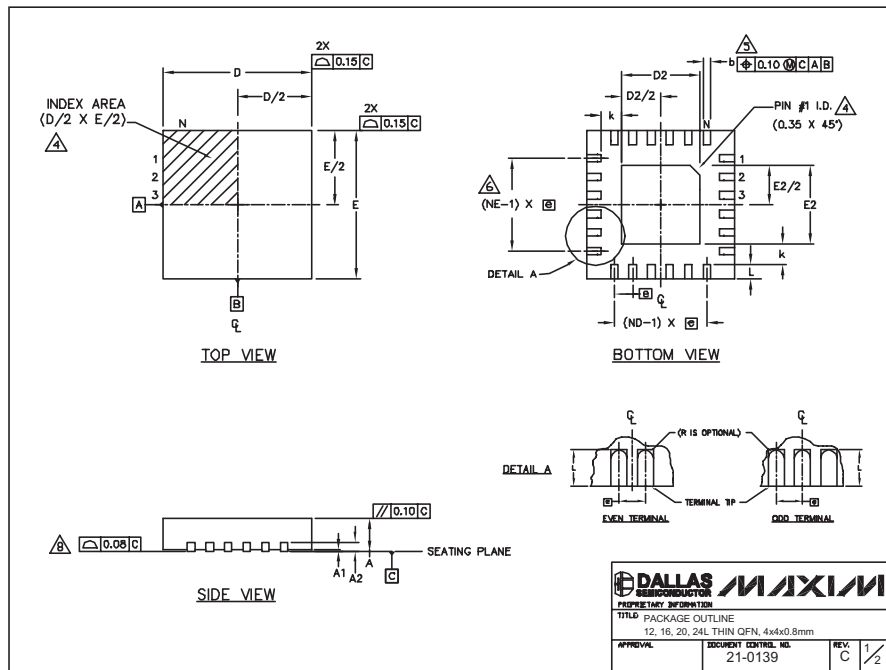

| COMMON DIMENSIONS | | | | | | | | | | | | |
|-------------------|-----------|------|------|-----------|------|------|-----------|------|------|-----------|------|------|
| PKG REF. | 12L 4x4 | | | 16L 4x4 | | | 20L 4x4 | | | 24L 4x4 | | |
| | MIN. | NDM. | MAX. | MIN. | NDM. | MAX. | MIN. | NDM. | MAX. | MIN. | NDM. | MAX. |
| A | 0.70 | 0.75 | 0.80 | 0.70 | 0.75 | 0.80 | 0.70 | 0.75 | 0.80 | 0.70 | 0.75 | 0.80 |
| AL | 0.0 | 0.02 | 0.05 | 0.0 | 0.02 | 0.05 | 0.0 | 0.02 | 0.05 | 0.0 | 0.02 | 0.05 |
| A2 | 0.20 REF. | | | 0.20 REF. | | | 0.20 REF. | | | 0.20 REF. | | |
| b | 0.25 | 0.30 | 0.35 | 0.25 | 0.30 | 0.35 | 0.20 | 0.25 | 0.30 | 0.18 | 0.23 | 0.30 |
| D | 3.90 | 4.00 | 4.10 | 3.90 | 4.00 | 4.10 | 3.90 | 4.00 | 4.10 | 3.90 | 4.00 | 4.10 |
| E | 3.90 | 4.00 | 4.10 | 3.90 | 4.00 | 4.10 | 3.90 | 4.00 | 4.10 | 3.90 | 4.00 | 4.10 |
| e | 0.80 BSC. | | | 0.65 BSC. | | | 0.50 BSC. | | | 0.50 BSC. | | |
| k | 0.25 | - | - | 0.25 | - | - | 0.25 | - | - | 0.25 | - | - |
| L | 0.45 | 0.55 | 0.65 | 0.45 | 0.55 | 0.65 | 0.45 | 0.55 | 0.65 | 0.30 | 0.40 | 0.50 |
| N | 12 | | | 16 | | | 20 | | | 24 | | |
| ND | 3 | | | 4 | | | 5 | | | 6 | | |
| NE | 3 | | | 4 | | | 5 | | | 6 | | |
| JEDEC Var. | WGGB | | | VGGC | | | WGGD-1 | | | WGGD-2 | | |

| PKG CODES | D2 | | | E2 | | | DOWN BONDS ALLOWED |
|-----------|------|------|------|------|------|------|--------------------|
| | MIN. | NDM. | MAX. | MIN. | NDM. | MAX. | |
| T1244-2 | 1.95 | 2.10 | 2.25 | 1.95 | 2.10 | 2.25 | NO |
| T1244-3 | 1.95 | 2.10 | 2.25 | 1.95 | 2.10 | 2.25 | YES |
| T1244-4 | 1.95 | 2.10 | 2.25 | 1.95 | 2.10 | 2.25 | NO |
| T1644-2 | 1.95 | 2.10 | 2.25 | 1.95 | 2.10 | 2.25 | NO |
| T1644-3 | 1.95 | 2.10 | 2.25 | 1.95 | 2.10 | 2.25 | YES |
| T1644-4 | 1.95 | 2.10 | 2.25 | 1.95 | 2.10 | 2.25 | NO |
| T2044-1 | 1.95 | 2.10 | 2.25 | 1.95 | 2.10 | 2.25 | NO |
| T2044-2 | 1.95 | 2.10 | 2.25 | 1.95 | 2.10 | 2.25 | YES |
| T2044-3 | 1.95 | 2.10 | 2.25 | 1.95 | 2.10 | 2.25 | NO |
| T2444-1 | 2.45 | 2.60 | 2.63 | 2.45 | 2.60 | 2.63 | NO |
| T2444-2 | 1.95 | 2.10 | 2.25 | 1.95 | 2.10 | 2.25 | YES |
| T2444-3 | 2.45 | 2.60 | 2.63 | 2.45 | 2.60 | 2.63 | YES |
| T2444-4 | 2.45 | 2.60 | 2.63 | 2.45 | 2.60 | 2.63 | NO |

NOTES:

- DIMENSIONING & TOLERANCING CONFORM TO ASME Y14.5M-1994.
- ALL DIMENSIONS ARE IN MILLIMETERS, ANGLES ARE IN DEGREES.
- N IS THE TOTAL NUMBER OF TERMINALS.
- THE TERMINAL #1 IDENTIFIER AND TERMINAL NUMBERING CONVENTION SHALL CONFORM TO JEDEC 95-1 SPP-012. DETAILS OF TERMINAL #1 IDENTIFIER ARE OPTIONAL, BUT MUST BE LOCATED WITHIN THE ZONE INDICATED. THE TERMINAL #1 IDENTIFIER MAY BE EITHER A MOLD OR MARKED FEATURE.
- DIMENSION b APPLIES TO METALLIZED TERMINAL AND IS MEASURED BETWEEN 0.25 mm AND 0.30 mm FROM TERMINAL TIP.
- ND AND NE REFER TO THE NUMBER OF TERMINALS ON EACH D AND E SIDE RESPECTIVELY.
- DEPOPULATION IS POSSIBLE IN A SYMMETRICAL FASHION.
- COPLANARITY APPLIES TO THE EXPOSED HEAT SINK SLUG AS WELL AS THE TERMINALS.
- DRAWING CONFORMS TO JEDEC M0220, EXCEPT FOR T2444-1, T2444-3 AND T2444-4.

DALLAS MAXIM
SEMICONDUCTOR

PROPRIETARY INFORMATION

TITLE PACKAGE OUTLINE
12, 16, 20, 24L THIN QFN, 4x4x0.8mm

APPROVAL: _____ DOCUMENT CONTROL NO. 21-0139 REV. C 2/2

Low-Cost, Mono/Stereo, 1.4W Differential Audio Power Amplifiers

Package Information (continued)

(The package drawing(s) in this data sheet may not reflect the most current specifications. For the latest package outline information go to www.maxim-ic.com/packages.)

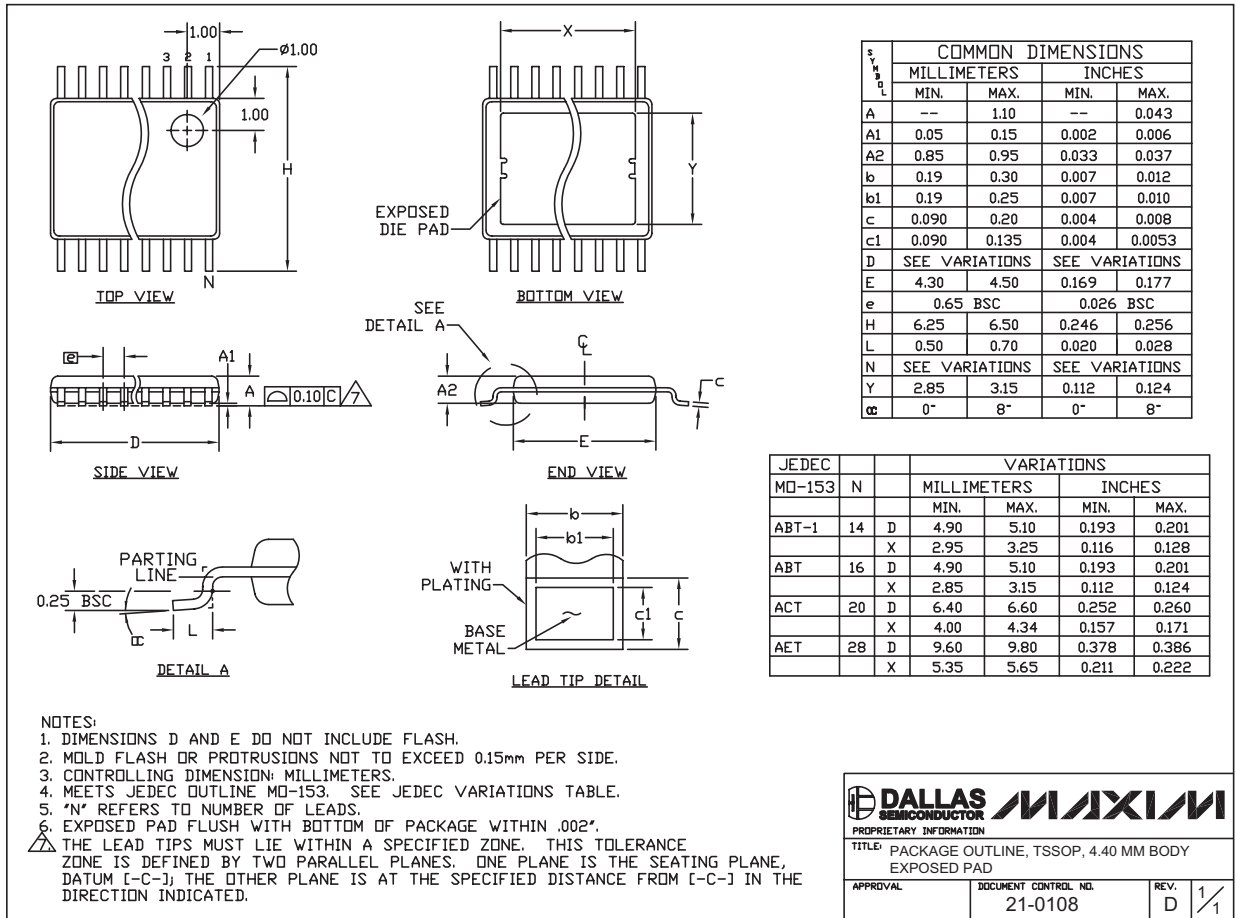

TSSOP 4.4mm BODY.EPS

MAX9718/MAX9719

DALLAS SEMICONDUCTOR **MAXIM**
PROPRIETARY INFORMATION
TITLE: PACKAGE OUTLINE, TSSOP, 4.40 MM BODY EXPOSED PAD
APPROVAL: _____ DOCUMENT CONTROL NO. 21-0108 REV. D 1/1

Maxim cannot assume responsibility for use of any circuitry other than circuitry entirely embodied in a Maxim product. No circuit patent licenses are implied. Maxim reserves the right to change the circuitry and specifications without notice at any time.

Maxim Integrated Products, 120 San Gabriel Drive, Sunnyvale, CA 94086 408-737-7600 _____ **23**