

# AN8480NSB

## 3-phase full-wave motor driver IC

### Overview

The AN8480NSB is a 3-phase full-wave motor driver IC with a reverse rotation brake/short brake changeover function, incorporating a thermal protection circuit with its protection monitor pin.

### Features

- 3-phase full-wave and snubberless
- FG output
- Current limit
- Reverse rotation prevention
- Thermal protection circuit built-in (with thermal protection monitor pin)

### Applications

- Various types of optical disk drive

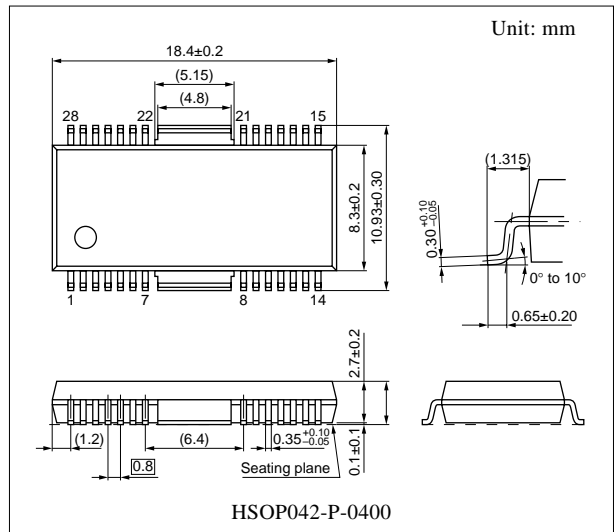

### Block Diagram

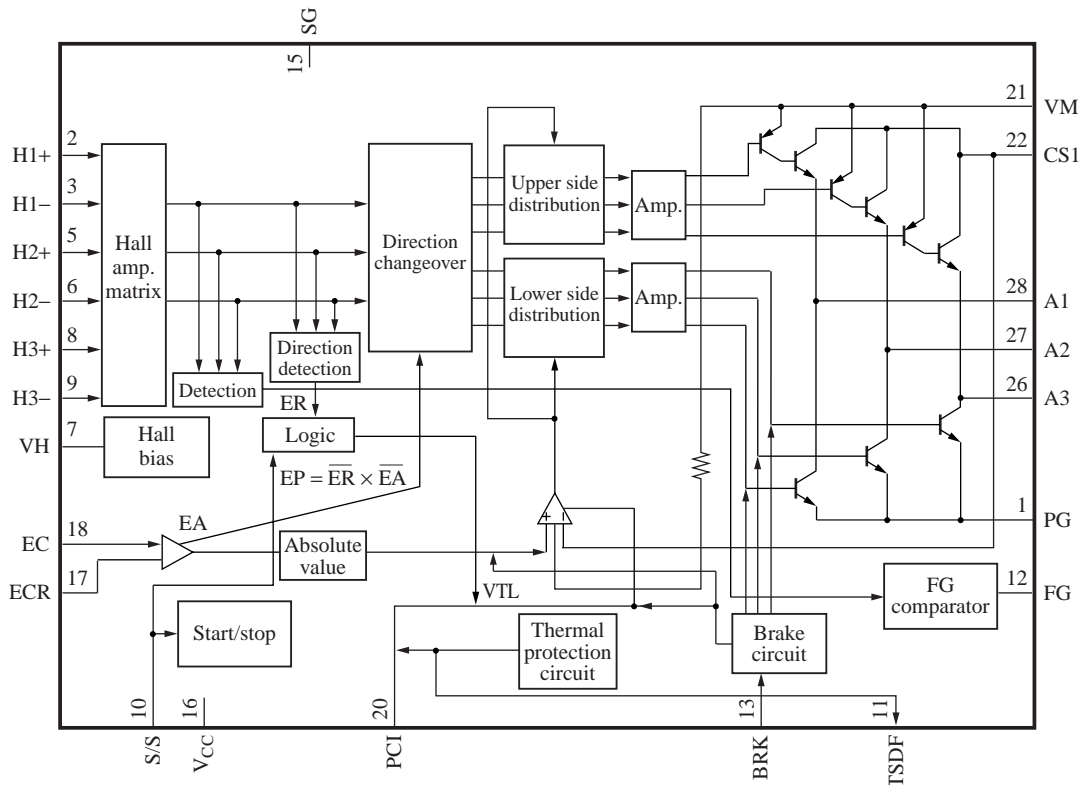

### ■ Pin Descriptions

Pin No.	Symbol	Description	Pin No.	Symbol	Description
1	PG	Power GND pin	15	SG	Signal GND pin
2	H1+	Hall element-1 positive input pin	16	V <sub>CC</sub>	Supply voltage pin
3	H1-	Hall element-1 negative input pin	17	ECR	Torque command reference input pin
4	N.C.	N.C.	18	EC	Torque command input pin
5	H2+	Hall element-2 positive input pin	19	N.C.	N.C.
6	H2-	Hall element-2 negative input pin	20	PCI	Current feedback phase compensation pin
7	VH	Hall bias pin	21	VM	Motor supply voltage pin
8	H3+	Hall element-3 positive input pin	22	CS	Current det. pin 1
9	H3-	Hall element-3 negative input pin	23	N.C.	N.C.
10	SS	Start/stop changeover pin	24	N.C.	N.C.
11	TFLG	Thermal protection monitor pin	25	N.C.	N.C.
12	FG	FG signal output pin	26	A3	Drive output 3
13	BRK	Brake mode setting pin	27	A2	Drive output 2
14	N.C.	N.C.	28	A1	Drive output 1

### ■ Absolute Maximum Ratings

Parameter	Symbol	Rating	Unit
Supply voltage	V <sub>CC</sub>	7.0	V
	V <sub>M</sub>	14.4	
Control signal input voltage *4	V <sub>(n)</sub>	0 to V <sub>CC</sub>	V
Supply current	I <sub>CC</sub>	30	mA
Output current *3	I <sub>O(n)</sub>	±1 200	mA
Hall bias current	I <sub>HB</sub>	50	mA
Power dissipation *2	P <sub>D</sub>	667	mW
Operating ambient temperature *1	T <sub>opr</sub>	-20 to +70	°C
Storage temperature *1	T <sub>stg</sub>	-55 to +150	°C

Note) Do not apply external currents or voltages to any pins not specifically mentioned.

For circuit currents, '+' denotes current flowing into the IC, and '-' denotes current flowing out of the IC.

\*1: Except for the operating ambient temperature and storage temperature, all ratings are for T<sub>a</sub> = 25°C.

\*2: For 70°C and IC alone.

\*3: n = 1, 22, 26, 27, 28

\*4: n = 2, 3, 5, 6, 8, 9, 10, 13, 17, 18

### ■ Recommended Operating Range

Parameter	Symbol	Range	Unit
Supply voltage	V <sub>CC</sub>	4.25 to 5.5	V
	V <sub>M</sub>	4.5 to 14	

■ Electrical Characteristics at  $T_a = 25^\circ\text{C}$ 

Parameter	Symbol	Conditions	Min	Typ	Max	Unit
<b>Overall</b>						
Circuit current 1	$I_{CC1}$	$V_{CC} = 5\text{ V}$ in power save mode	—	0	0.1	mA
Circuit current 2	$I_{CC2}$	$V_{CC} = 5\text{ V}$ , $I_O = 0\text{ mA}$	1	8	16	mA
<b>Start/stop</b>						
Start voltage	$V_{START}$	Voltage with which a circuit operates at $V_{CC} = 5\text{ V}$ and $L \rightarrow H$	2.7	—	—	V
Stop voltage	$V_{STOP}$	Voltage with which a circuit becomes off at $V_{CC} = 5\text{ V}$ and $H \rightarrow L$	—	—	0.7	V
Medium voltage	$V_{MED}$	Voltage with which $V_{PC1}$ becomes low at $V_{CC} = 5\text{ V}$ and $EC = 0\text{ V}$	1.55	—	1.75	V
<b>Hall bias</b>						
Hall bias voltage	$V_{HB}$	$V_{CC} = 5\text{ V}$ , $I_{HB} = 20\text{ mA}$	0.7	1.2	1.6	V
<b>Hall amplifier</b>						
Input bias current	$I_{BH}$	$V_{CC} = 5\text{ V}$	—	1	5	$\mu\text{A}$
In-phase input voltage range	$V_{HBR}$	$V_{CC} = 5\text{ V}$	1.5	—	4.0	V
Minimum input level	$V_{INH}$	$V_{CC} = 5\text{ V}$	60	—	—	mV[p-p]
<b>Torque command</b>						
In-phase input voltage range	EC	$V_{CC} = 5\text{ V}$	0.5	—	3.9	V
Offset voltage	$EC_{OF}$	$V_{CC} = 5\text{ V}$	-100	0	100	mV
Dead zone	$EC_{DZ}$	$V_{CC} = 5\text{ V}$	25	75	125	mV
Input current	$EC_{IN}$	$V_{CC} = 5\text{ V}$ , $EC = ECR = 1.65\text{ V}$	-5	-1	—	$\mu\text{A}$
Input/output gain	$A_{CS}$	$V_{CC} = 5\text{ V}$ , $R_{CS} = 0.5\ \Omega$	0.75	1.0	1.25	A/V
<b>Output</b>						
High-level output saturation voltage	$V_{OH}$	$V_{CC} = 5\text{ V}$ , $I_O = -300\text{ mA}$	—	0.9	1.6	V
Low-level output saturation voltage	$V_{OL}$	$V_{CC} = 5\text{ V}$ , $I_O = 300\text{ mA}$	—	0.2	0.6	V
Torque limit current	$I_{TL}$	$V_{CC} = 5\text{ V}$ , $R_{CS} = 0.5\ \Omega$	400	500	600	mA
<b>FG</b>						
FG output high-level	$FG_H$	$V_{CC} = 5\text{ V}$ , $I_{FG} = -0.01\text{ mA}$	3.0	—	$V_{CC}$	V
FG output low-level	$FG_L$	$V_{CC} = 5\text{ V}$ , $I_{FG} = 0.01\text{ mA}$	—	—	0.5	V
In-phase input voltage range	$V_{FGR}$	$V_{CC} = 5\text{ V}$ , Input D-range at H2+, H2-	1.5	—	3.0	V
FG hysteresis width	$H_{FG}$	$V_{CC} = 5\text{ V}$	1	10	20	mV
<b>Brake circuit</b>						
Short brake model level	$V_{SBR}$	$V_{CC} = 5\text{ V}$	—	—	1.0	V
Reverse rotation brake mode level	$V_{RBR}$	$V_{CC} = 5\text{ V}$	3.5	—	—	V
Short brake start level	$V_{SBRL}$	$V_{CC} = 5\text{ V}$ , $ECR = 1.65\text{ V}$	1.65	1.74	—	V
Short brake current	$I_{SBR}$	$V_{CC} = 5\text{ V}$	12	35	—	mA

## ■ Electrical Characteristics at $T_a = 25^\circ\text{C}$ (continued)

### • Design reference data

Note) The characteristics listed below are theoretical values based on the IC design and are not guaranteed.

Parameter	Symbol	Conditions	Min	Typ	Max	Unit
Thermal protection						
Thermal protection operating temperature	$T_{SDON}$	$V_{CC} = 5\text{ V}, \Delta EC = 100\text{ mV}$	—	160	—	$^\circ\text{C}$
Thermal protection hysteresis width	$\Delta T_{SD}$	$V_{CC} = 5\text{ V}, \Delta EC = 100\text{ mV}$	—	45	—	$^\circ\text{C}$
Thermal protection flag						
Level at thermal protection = on	$V_{TSDON}$	$V_{CC} = 5\text{ V}$	—	—	0.5	V
Level at thermal protection = off	$V_{TSDOFF}$	$V_{CC} = 5\text{ V}$	3.0	—	—	V

## ■ Usage Notes

Prevent this IC from being line-to-ground fault. (To be concrete, do not short-circuit any of A1 (pin 28), A2 (pin 27) and A3 (pin 26) with VM pin (pin 21).)

## ■ Application Notes

- $P_D - T_a$  curves of HSOP042-P-0400

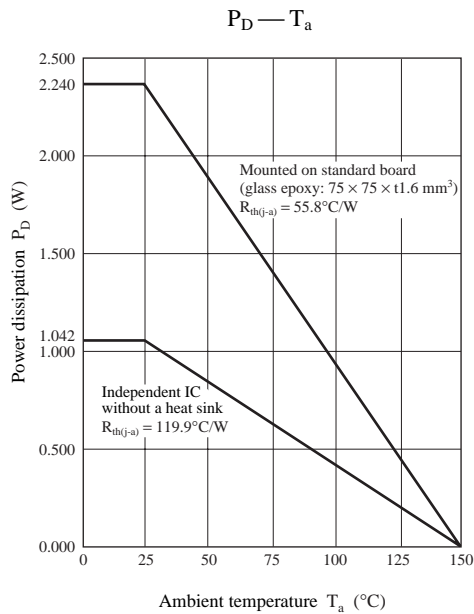

■ Application Notes (continued)

• Phase conditions between Hall input and output current

Phase of Hall pin			
	H1+	H2+	H3+
A	H	M	L
B	H	L	M
C	M	L	H
D	L	M	H
E	L	H	M
F	M	H	L

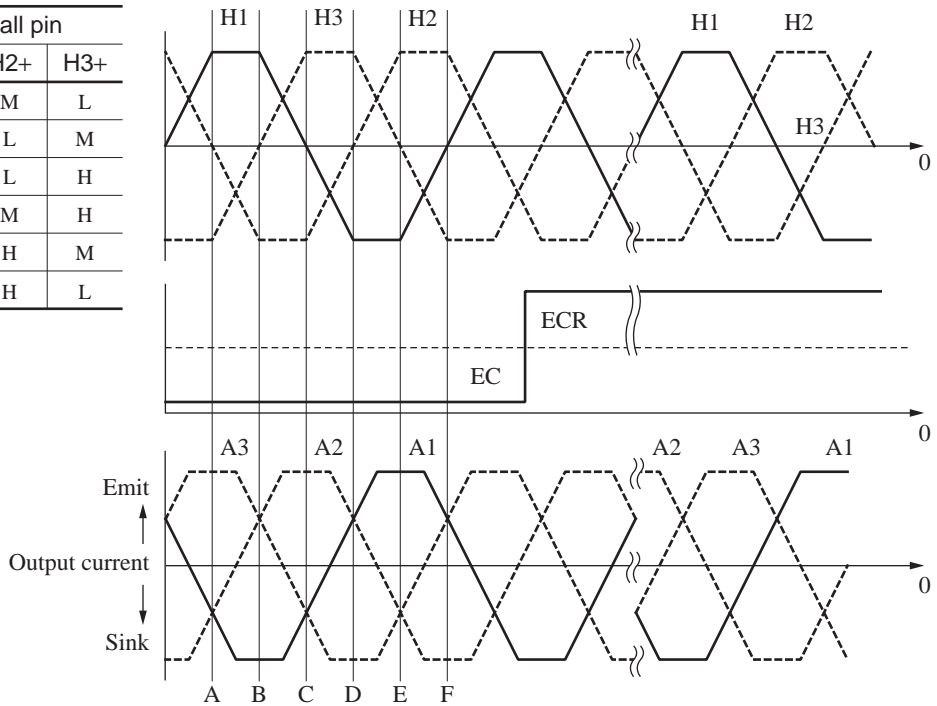

• Power consumption calculation method

You can find a rough value of electric power to be consumed in the IC in the following method and the use of EXCEL (computer soft ware) will enable you to put it on a graph.

Calculating formula:

1. Let an induced voltage generated in each phase as below:

(Reference to a motor center point)

$$E_{A1} = E_O \times \sin (X) \cdots (1)$$

$$E_{A2} = E_O \times \sin (X+120) \cdots (2)$$

$$E_{A3} = E_O \times \sin (X+240) \cdots (3)$$

X: Phase angle

2. Let a current flowing in each phase as below:

$$I_{A1} = I_O \times \sin (X) \cdots (4)$$

$$I_{A2} = I_O \times \sin (X+120) \cdots (5)$$

$$I_{A3} = I_O \times \sin (X+240) \cdots (6)$$

3. The voltages generated by a wire-wound resistance of a motor are:

$$V_{R1} = I_{A1} \times R \cdots (7)$$

$$V_{R2} = I_{A2} \times R \cdots (8)$$

$$V_{R3} = I_{A3} \times R \cdots (9)$$

4. In each phase, add the voltage generated by an induced voltage and that by a wire-wound resistance.

$$V_{A1}' = (1) + (4)$$

$$V_{A2}' = (2) + (5)$$

$$V_{A3}' = (3) + (6)$$

5. As the lowest voltage in each phase angle must be 0 V, you can get the voltage to be generated in each phase by means of subtracting the lowest voltage from the voltage of the remaining two phases.

$$V_{A1} = V_{A1}' - \text{MIN} (V_{A1}', V_{A2}', V_{A3}') \cdots (10)$$

$$V_{A2} = V_{A2}' - \text{MIN} (V_{A1}', V_{A2}', V_{A3}') \cdots (11)$$

$$V_{A3} = V_{A3}' - \text{MIN} (V_{A1}', V_{A2}', V_{A3}') \cdots (12)$$

6. Subtract the supply voltage from each phase's voltage found in item 5 and then multiply it by each phase's current, so that you can get the power consumption.

$$P = \sum_{n=1}^3 (12 - V_{An}) \times I_{An}$$

■ Application Notes (continued)

• Theory of thermal resistance

A chip temperature or the fin temperature can be understood in the same way as Ohm's Law.

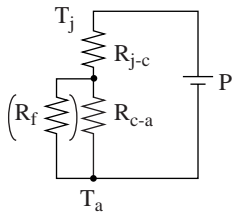

- $T_j$  : Chip temperature
- $T_a$  : Ambient temperature
- $P$  : Electric power generated by IC
- $R_{j-c}$  : Thermal resistance between a chip and a package
- $R_{c-a}$  : Thermal resistance between a package and a surface of a heat sink or free air
- $R_f$  : Thermal resistance between a package and surface of a heat sink

$$T_j = T_a + P \times (R_{j-c} + R_{c-a} // R_f)$$

Make sure that  $T_j$  does not exceed  $150^\circ\text{C}$ .

If it exceeds  $150^\circ\text{C}$ , you can suppress the rise of a chip temperature by adding a heat sink which is equivalent to  $R_f$  in the above figure.

$$T_j = T_a + P \times (R_{j-c} + R_{c-a} // R_f)$$

A package surface and the fin are available for a temperature measurement. But the fin part is recommendable for measurement because a package surface measurement does not always promise you a consistent measuring result.

■ Application Circuit Example

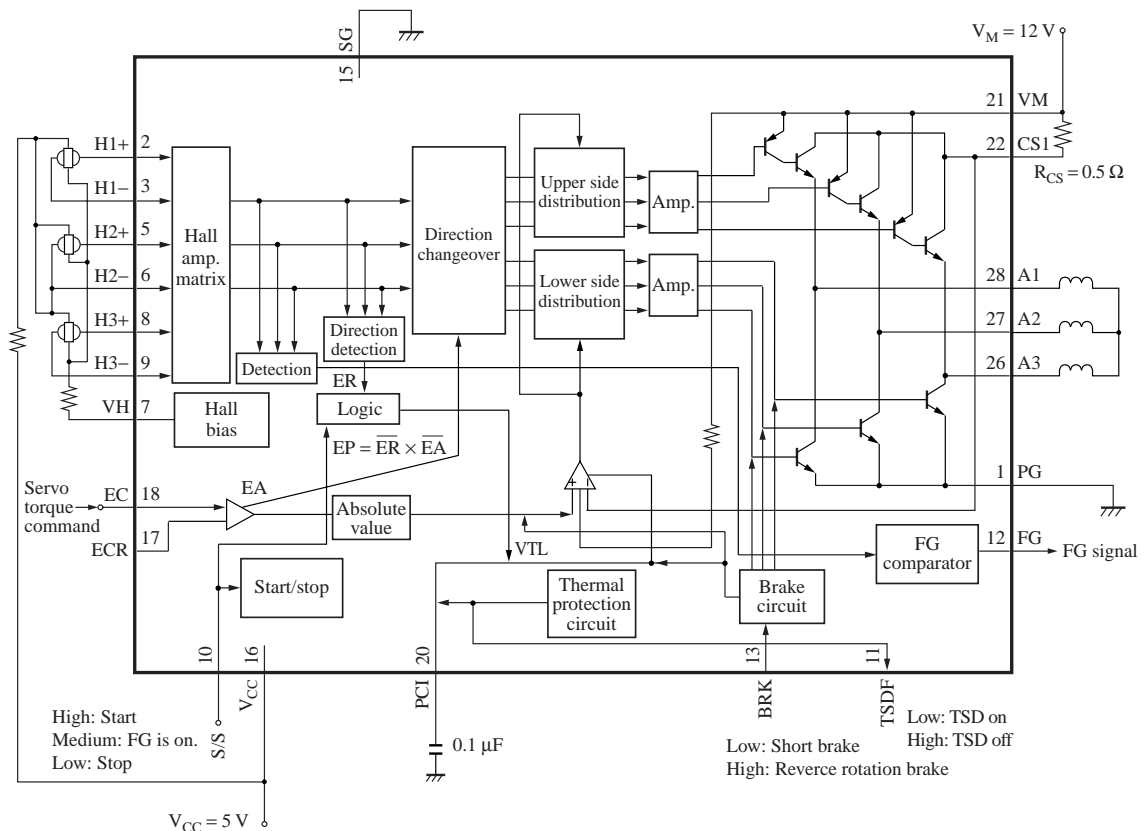

## Request for your special attention and precautions in using the technical information and semiconductors described in this material

- (1) An export permit needs to be obtained from the competent authorities of the Japanese Government if any of the products or technologies described in this material and controlled under the "Foreign Exchange and Foreign Trade Law" is to be exported or taken out of Japan.
- (2) The technical information described in this material is limited to showing representative characteristics and applied circuit examples of the products. It does not constitute the warranting of industrial property, the granting of relative rights, or the granting of any license.
- (3) The products described in this material are intended to be used for standard applications or general electronic equipment (such as office equipment, communications equipment, measuring instruments and household appliances).  
Consult our sales staff in advance for information on the following applications:
  - Special applications (such as for airplanes, aerospace, automobiles, traffic control equipment, combustion equipment, life support systems and safety devices) in which exceptional quality and reliability are required, or if the failure or malfunction of the products may directly jeopardize life or harm the human body.
  - Any applications other than the standard applications intended.
- (4) The products and product specifications described in this material are subject to change without notice for reasons of modification and/or improvement. At the final stage of your design, purchasing, or use of the products, therefore, ask for the most up-to-date Product Standards in advance to make sure that the latest specifications satisfy your requirements.
- (5) When designing your equipment, comply with the guaranteed values, in particular those of maximum rating, the range of operating power supply voltage and heat radiation characteristics. Otherwise, we will not be liable for any defect which may arise later in your equipment.  
Even when the products are used within the guaranteed values, redundant design is recommended, so that such equipment may not violate relevant laws or regulations because of the function of our products.
- (6) When using products for which dry packing is required, observe the conditions (including shelf life and after-unpacking standby time) agreed upon when specification sheets are individually exchanged.
- (7) No part of this material may be reprinted or reproduced by any means without written permission from our company.

## Please read the following notes before using the datasheets

- A. These materials are intended as a reference to assist customers with the selection of Panasonic semiconductor products best suited to their applications.  
Due to modification or other reasons, any information contained in this material, such as available product types, technical data, and so on, is subject to change without notice.  
Customers are advised to contact our semiconductor sales office and obtain the latest information before starting precise technical research and/or purchasing activities.
- B. Panasonic is endeavoring to continually improve the quality and reliability of these materials but there is always the possibility that further rectifications will be required in the future. Therefore, Panasonic will not assume any liability for any damages arising from any errors etc. that may appear in this material.
- C. These materials are solely intended for a customer's individual use.  
Therefore, without the prior written approval of Panasonic, any other use such as reproducing, selling, or distributing this material to a third party, via the Internet or in any other way, is prohibited.