

AMI Semiconductor

# AMIS-3062X Bus Microstepping Motordriver

## Key Features

### Motor Driver

- Microstepping (1/2, 1/4, 1/8, 1/16)
- Low resonance & noise
- High resolution
- Programmable peak current up to 800mA
- 20kHz PWM current-control
- Automatic selection of fast and slow decay mode
- Internal fly-back FETs
- Fully integrated current sense
- 8V-29V supply voltage
- Automotive compliant
- Full diagnostics and status information

### Controller with RAM and OTP

- Position controller
- Configurable speeds, acceleration and deceleration
- Flexible Hold-current
- Movement/position sensor-input
- Optional stall detection

### LIN Control Interface (AMIS-30621 only)

- Physical - and data-link - layer (conform to LIN rev. 1.3)
- Dynamically allocated identifiers
- Up to 128 node addresses

### Serial Interface (AMIS-30622 only)

- 2-wire serial interface
- 5V microcontroller compatible
- Up to 32 node addresses

## Product Description

The AMIS-3062X is a stepper motor driver family with position controller and control/diagnostics interface integrated in one single chip.

The family consists of two products:

- AMIS-30621 with LIN interface, ready to build dedicated mechatronics solutions connected remotely with a LIN master.
- AMIS-30622 with SERIAL interface, ready to act as peripheral device next to a microcontroller.

## Applications and Benefits

The AMIS-3062X family is ideally suited for small positioning applications. Target markets include: automotive (headlamp alignment, idle control, cruise), industrial equipment (lighting, fluid control, labeling, process, XYZ tables) and building automation (HVAC, surveillance, satellite dish positioning). Suitable applications typically have multiple axes or require mechatronic solutions with the driver chip mounted directly on the motor.

The high abstraction level of the products' command set reduces the load of the processor on the master side. Scaling of the application towards number of axes is straightforward: hardware - and software designs are



### Protection

- Over-current protection
- Under-voltage management
- Over-voltage protection
- High-temp warning and shutdown
- Low-temp warning
- LIN bus short-circuit protection to supply and ground

### Power Saving

- Power-down supply current <math><50\mu\text{A}</math>
- 5V regulator with wake-up on LIN activity

### EMI Compatibility

- Power drivers with slope control

The chip receives high-level positioning instructions through the interface and subsequently drives the motor coils until the desired position is reached. The on-chip position controller is configurable (OTP and Interface) for different motor types, positioning ranges and parameters for speed, acceleration and deceleration. The AMIS-3062X acts as a slave on the bus and the master can fetch specific status information like actual position, error flags, etc. from each individual slave node.

extended in a modular way, without severely effecting the demands on the master microcontroller. The bus structure simplifies PCB track-layout and/or wiring architectures.

Microstepping operation removes the design trade-off between minimal operation speed and avoiding the risk of noise and step-loss due to resonance phenomena. The stall-detection feature (optional) offers silent, yet accurate position-calibrations during the referencing run and allows semi-closed loop operation when approaching the mechanical end-stops.

All these benefits result in reduced system-cost and time-to-market and improved technical performance.

## Ordering Codes

Part N°	<b>AMIS-30621</b>	Part N°	<b>AMIS-30622</b>
Bus	<b>LIN</b>	Bus	<b>Serial</b>
Package	<b>SOIC-20</b>	Package	<b>SOIC-20</b>
Peak Current	<b>800mA</b>	Peak Current	<b>800mA</b>
Temp Range	<b>-40°C...125°C</b>	Temp Range	<b>-40°C...125°C</b>

## Functional Block Diagram

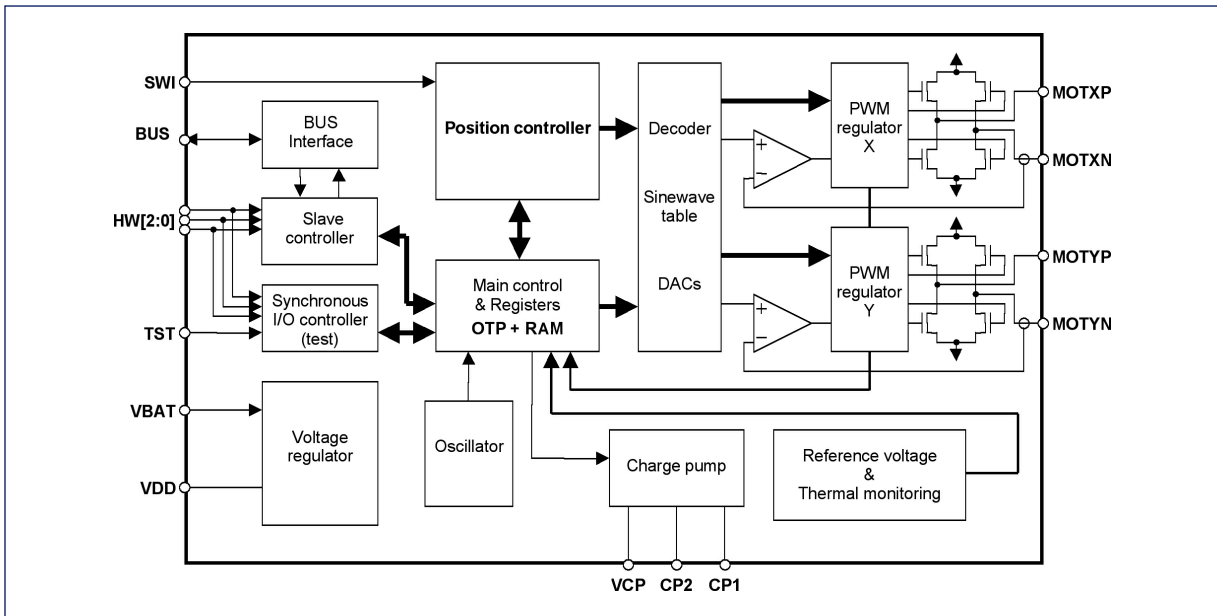

## Typical Application

