

# Master-Slave Flip-Flop

Master slave construction renders the MC1670 relatively insensitive to the shape of the clock waveform, since only the voltage levels at the clock inputs control the transfer of information from data input (D) to output.

When both clock inputs (C1 and C2) are in the low state, the data input affects only the "Master" portion of the flip-flop. The data present in the "Master" is transferred to the "Slave" when clock inputs (C1 "OR" C2) are taken from a low to a high level. In other words, the output state of the flip-flop changes on the positive transition of the clock pulse.

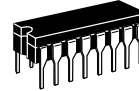
While either C1 "OR" C2 is in the high state, the "Master" (and data input) is disabled.

Asynchronous Set (S) and Reset (R) override Clock (C) and Data (D) inputs.

Power Dissipation = 220 mW typ (No Load)

$f_{Tog}$  = 350 MHz typ

## MC1670



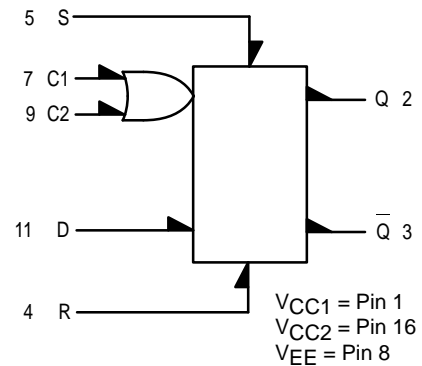
**L SUFFIX**  
CERAMIC PACKAGE  
CASE 620-10

**TRUTH TABLE**

R	S	D	C	$Q_{n+1}$
L	H	X	X	H
H	L	X	X	L
H	H	X	X	N.D.
L	L	L	L	$Q_n$
L	L	L	H	L
L	L	L	L	$Q_n$
L	L	H	L	$Q_n$
L	L	H	H	H
L	L	H	L	$Q_n$

ND = Not Defined  
C = C1 + C2

**LOGIC DIAGRAM**



### ELECTRICAL CHARACTERISTICS

Characteristic	Symbol	-30°C		+25°C		+85°C		Unit
		Min	Max	Min	Max	Min	Max	
Power Supply Drain Current	$I_E$	—	—	—	48	—	—	mAdc
Input Current Set, Reset Clock Data	$I_{inH}$	—	—	—	550	—	—	$\mu$ Adc
Switching Times								ns
Propagation Delay	$t_{pd}$	1.0	2.7	1.1	2.5	1.1	2.9	
Rise Time (10% to 90%)	$t^+$	0.9	2.7	1.0	2.5	1.0	2.9	ns
Fall Time (10% to 90%)	$t^-$	0.5	2.1	0.6	1.9	0.6	2.3	ns
Setup Time	$t_{S"1"}$ $t_{S"0"}$	—	—	0.4	—	—	—	ns
Hold Time	$t_{H"1"}$ $t_{H"0"}$	—	—	0.3	—	—	—	ns
Toggle Frequency	$f_{Tog}$	270	—	300	—	270	—	MHz

**PIN ASSIGNMENT**

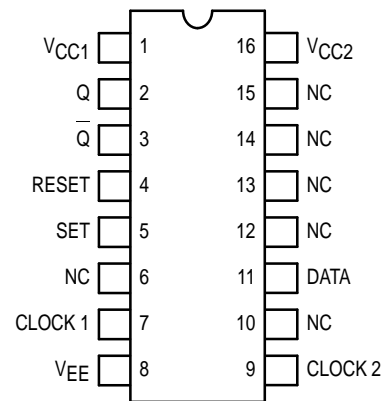


FIGURE 1 — TOGGLE FREQUENCY WAVEFORMS

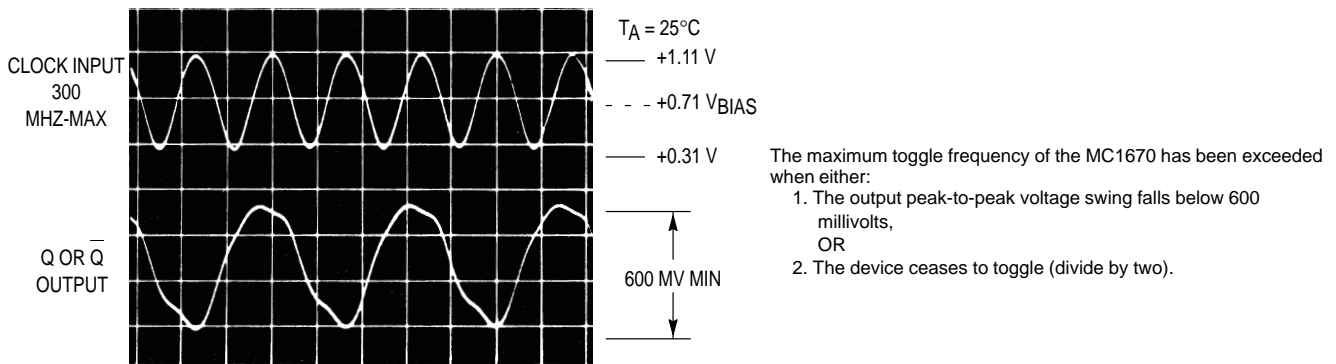


FIGURE 2 — MAXIMUM TOGGLE FREQUENCY (TYPICAL)

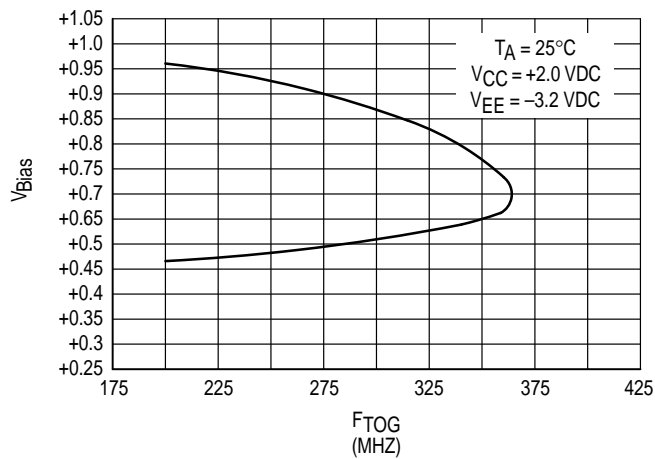
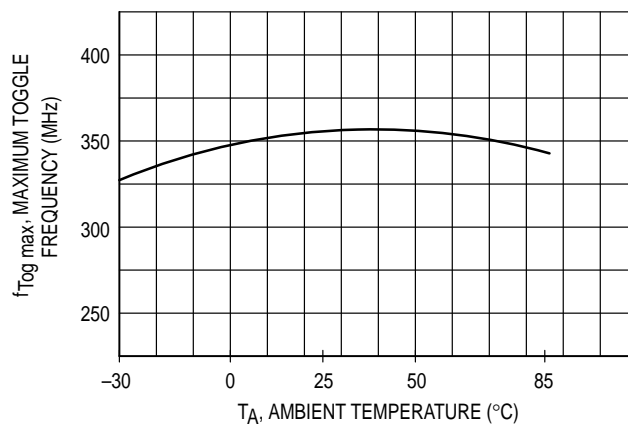


Figure 2 illustrates the variation in toggle frequency with the dc offset voltage ( $V_{Bias}$ ) of the input clock signal. Figures 4 and 5 illustrate minimum clock pulse width recommended for reliable operation of the MC1670.

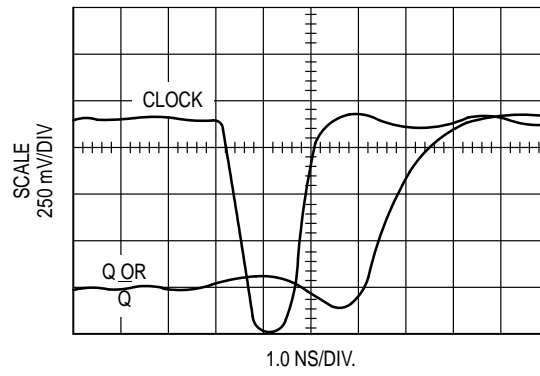
FIGURE 3 — TYPICAL MAXIMUM TOGGLE FREQUENCY versus TEMPERATURE



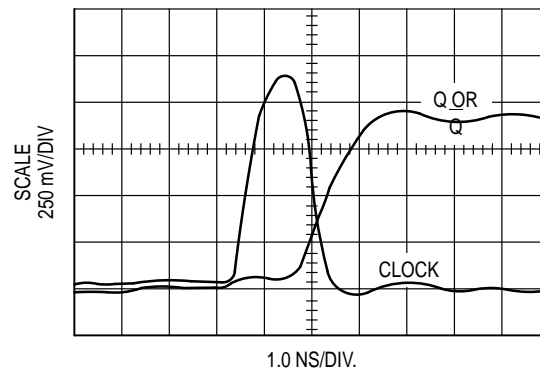
Temperature	-30°C	+25°C	+85°C
$V_{Bias}$	+0.66 Vdc	+0.71 Vdc	+0.765 Vdc

Note: All power supply and logic levels are shown shifted 2.0 volts positive.

**FIGURE 4 — MINIMUM “DOWN TIME” TO CLOCK  
OUTPUT LOAD = 50 Ω**

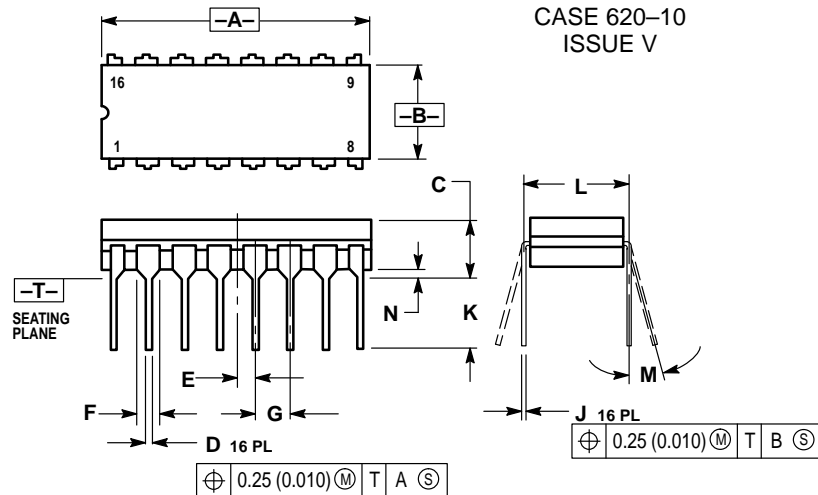


**FIGURE 5 — MINIMUM “UP TIME” TO CLOCK  
OUTPUT LOAD = 50 Ω**



OUTLINE DIMENSIONS

L SUFFIX  
CERAMIC DIP PACKAGE  
CASE 620-10  
ISSUE V



- NOTES:
1. DIMENSIONING AND TOLERANCING PER ANSI Y14.5M, 1982.
  2. CONTROLLING DIMENSION: INCH.
  3. DIMENSION L TO CENTER OF LEAD WHEN FORMED PARALLEL.
  4. DIMENSION F MAY NARROW TO 0.76 (0.030) WHERE THE LEAD ENTERS THE CERAMIC BODY.

DIM	INCHES		MILLIMETERS	
	MIN	MAX	MIN	MAX
A	0.750	0.785	19.05	19.93
B	0.240	0.295	6.10	7.49
C	—	0.200	—	5.08
D	0.015	0.020	0.39	0.50
E	0.050 BSC		1.27 BSC	
F	0.055	0.065	1.40	1.65
G	0.100 BSC		2.54 BSC	
H	0.008	0.015	0.21	0.38
K	0.125	0.170	3.18	4.31
L	0.300 BSC		7.62 BSC	
M	0°	15°	0°	15°
N	0.020	0.040	0.51	1.01

Motorola reserves the right to make changes without further notice to any products herein. Motorola makes no warranty, representation or guarantee regarding the suitability of its products for any particular purpose, nor does Motorola assume any liability arising out of the application or use of any product or circuit, and specifically disclaims any and all liability, including without limitation consequential or incidental damages. "Typical" parameters which may be provided in Motorola data sheets and/or specifications can and do vary in different applications and actual performance may vary over time. All operating parameters, including "Typicals" must be validated for each customer application by customer's technical experts. Motorola does not convey any license under its patent rights nor the rights of others. Motorola products are not designed, intended, or authorized for use as components in systems intended for surgical implant into the body, or other applications intended to support or sustain life, or for any other application in which the failure of the Motorola product could create a situation where personal injury or death may occur. Should Buyer purchase or use Motorola products for any such unintended or unauthorized application, Buyer shall indemnify and hold Motorola and its officers, employees, subsidiaries, affiliates, and distributors harmless against all claims, costs, damages, and expenses, and reasonable attorney fees arising out of, directly or indirectly, any claim of personal injury or death associated with such unintended or unauthorized use, even if such claim alleges that Motorola was negligent regarding the design or manufacture of the part. Motorola and are registered trademarks of Motorola, Inc. Motorola, Inc. is an Equal Opportunity/Affirmative Action Employer.

How to reach us:

USA/EUROPE/Locations Not Listed: Motorola Literature Distribution; P.O. Box 5405, Denver, Colorado 80217. 1-800-441-2447

JAPAN: Nippon Motorola Ltd.; Tatsumi-SPD-JLDC, 6F Seibu-Butsuryu-Center, 3-14-2 Tatsumi Koto-Ku, Tokyo 135, Japan. 03-81-3521-8315

Mfax™: RMFAX0@email.sps.mot.com - TOUCHTONE 602-244-6609  
INTERNET: http://Design-NET.com

ASIA/PACIFIC: Motorola Semiconductors H.K. Ltd.; 8B Tai Ping Industrial Park, 51 Ting Kok Road, Tai Po, N.T., Hong Kong. 852-26629298

