

900MHz Low-IF 1.5Mbps FSK Transceiver

Final Datasheet

GENERAL DESCRIPTION

The ML2722 is a fully integrated 1.5Mbps frequency shift keyed (FSK) transceiver that operates in the unlicensed 900MHz ISM frequency band. The device has been optimized for digital cordless telephone applications and includes all the frequency generation, receive and transmit functions. Automatically adjusted filters eliminate mechanical tuning. The transmitter generates a -1 dBm FSK output signal. The single conversion Low-IF receiver has all the sensitivity and selective advantages of a traditional super-heterodyne without requiring costly, bulky external filters, while providing the integration advantages of direct conversion.

The phase locked loop (PLL) synthesizer is completely integrated, including the voltage controlled oscillator (VCO), tuning circuits, and VCO resonator. This allows the ML2722 to be used in frequency hopped spread spectrum (FHSS) applications.

The ML2722 contains internal voltage regulation. It also contains PLL and transmitter configuration registers. The device can be placed in a low power standby mode for current sensitive applications. It is packaged in a 32TQFP.

PIN CONFIGURATION

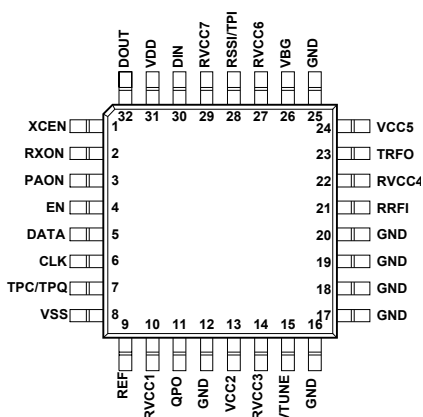

ORDERING INFORMATION

PART NUMBER	TEMPERATURE RANGE	PACKAGE	PUBLICATION
ML2722DH	-10°C to +60°C	32 Pin TQFP 7mm body	DS2722-F-05

FEATURES

- Single chip ISM band 900MHz Radio Transceiver with -1 dBm transmit output power
- 1.5Mbps maximum data rate
- Typical receiver sensitivity: -95dBm at 12.5% CER
- Fully integrated frequency synthesizer with internal VCO resonator
- Automatic filter calibration: Requires no mechanical tuning adjustments during manufacturing
- Low IF Receiver: No external IF filters required
- Control outputs correctly sequence and control external PA
- 3-wire control interface
- Analog RSSI output

APPLICATIONS

- 900MHz FSK Data Transceivers
 - Digital Cordless Phones
 - Wireless Streaming Media
 - Wireless PC Peripherals

BLOCK DIAGRAM

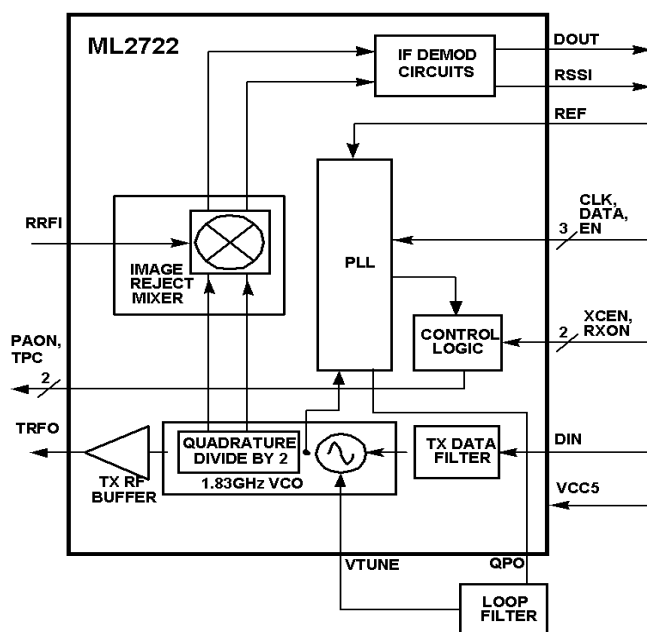

TABLE OF CONTENTS

GENERAL DESCRIPTION.....	1
PIN CONFIGURATION	1
ORDERING INFORMATION	1
FEATURES.....	1
APPLICATIONS.....	1
BLOCK DIAGRAM	1
TABLE OF CONTENTS	2
CHANGE LOG	2
SIMPLIFIED APPLICATIONS DIAGRAM.....	3
ELECTRICAL CHARACTERISTICS	4
PIN DESCRIPTIONS	7
FUNCTIONAL DESCRIPTION.....	13
MODES OF OPERATION	15
DATA INTERFACES.....	18
CONTROL INTERFACES AND REGISTER DESCRIPTIONS	20
PHYSICAL DIMENSIONS (INCHES/MILLIMETERS).....	27
ORDERING INFORMATION.....	27
WARRANTY	28

CHANGE LOG

VERSION	DATE	AUTHOR	CHANGES/COMMENTS
DS2722-F-03	9/26/03	Derby	Reformatted and updated from F02
DS2722-F-04	10/13/03	Derby	Error on Page 21 Table 5 – Divide Ratio = $f_c / 0.512$
DS2722-F-05	12/12/03	Derby	Some graphics printed poorly to PDF.

SIMPLIFIED APPLICATIONS DIAGRAM

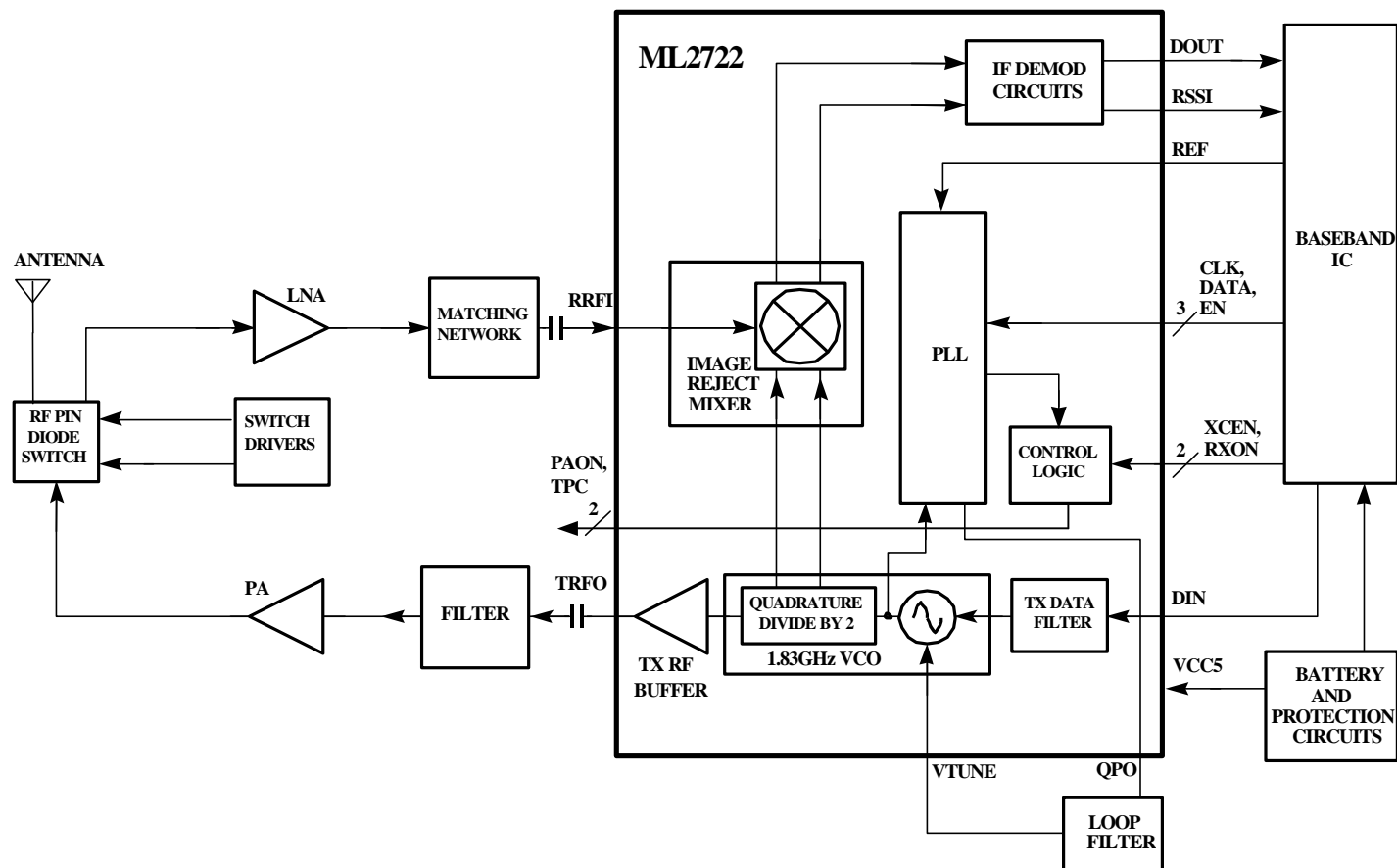

Figure 1. Simplified Application Diagram

ELECTRICAL CHARACTERISTICS

ABSOLUTE MAXIMUM RATINGS

Absolute maximum ratings are those values beyond which the device could be permanently damaged. Absolute maximum ratings are stress ratings only and functional device operation is not implied.

VDD, VCC5	6.0 V
VSS, GND	0 ± 0.3V
Junction Temperature	150°C
Storage Temperature Range	-65°C to 150°C
Lead Temperature (Soldering, 10s)	260°C

OPERATING CONDITIONS

Normal Temperature Range	-10°C to 60°C
VCC5 Range	2.7V to 4.5V
Thermal Resistance (θ_{JA})	100°C/W
VDD Range (VCC5 = VDD)	2.7V to 4.5V

Unless otherwise specified, VCC5 & VDD = 2.7V to 3.8V, T_A = Operating Temperature Range (Note 1) 6.144 or 12.288MHz reference frequency input

	PARAMETER	CONDITIONS	MIN	TYP	MAX	UNITS
POWER CONSUMPTION						
I_{STBY}	All Circuits, Standby Mode			10	100	μ A
I_{RX}, I_{TX}	Receive or Transmit Mode	$T_A = 25^\circ\text{C}$, VCC5 & VDD = 3.3V	30	50	63.5	mA
I_{RX}, I_{TX}	Receive or Transmit Mode	$T_A = \text{Operating Temperature Range}$	20	50	70	mA
SYNTHESIZER						
f_c	LO output frequency	In 512 KHz steps	902		928	MHz
Φ_N	Phase noise at driver output 1.2 MHz 3 MHz >7 MHz	VCO phase locked, loop bandwidth 50KHz. Discontinuities, other than reference spurs, not allowed.		-100 -120 -125		dBc/Hz
f_{REF}	LO PLL reference frequency at phase detector	PLL main divider input is at 1.83 GHz		1.024		MHz
N	LO division range integer	PLL divider limits	1024		4093	Count
I_P	LO charge pump sink/source current			5.5		mA
t_{TX2RX}	LO lock up time for Transmit/Receive frequency change	From RXON asserted		50		μ s
t_{FH}	LO lock up time for channel switch	From EN asserted, any channel change in 902 to 928 MHz band		100		μ s
t_{WAKE}	LO lock up time from sleep	From XCEN, PLL dividers programmed		240		μ s
V_{FREF}	Reference signal input level	6.144 or 12.288MHz sine wave, capacitively coupled	2.0		3.0	Vp-p

RECEIVER						
Z _{IN}	Receiver RF impedance	f _c =915 MHz		17-j50		Ω
NF	Receiver RF noise figure	f _c =915 MHz		9		dB
DR _{RX}	Data Rate	FSK modulation, fdev=±460KHz		1.536		Mbps
S	Input Sensitivity	For better than 12.5% CER		-95		dBm
BW _{RX}	Bandwidth	3dB nominal		770		kHz
P _{IMAX}	Maximum RX RF input	<12.5% CER at 1.536Mchip/s		8		dBm
I _{IP3}	Receiver input IP3	Test tones 2 and 4 channels away		-12		dBm
	LO Leakage at RXI			-80		dBm
IRR	Receive RF mixer image rejection	Measured at 3.5MHz offset		35		dB
	Adjacent channel rejection	-80dBm wanted signal <12.5% CER (a single interferer with 2GFSK modulation to give a -20dBc bandwidth of 1.5MHz) 1 channel 2 channels 3 or more channels		15 40 45		dB
	Receiver settling time	RXON high to valid data			120	μs
IF FILTERS						
f _{IFC}	IF filter center frequency	After Automatic Filter Alignment		1.024		MHz
BW _{IF}	IF filter 3dB bandwidth	After Automatic Filter Alignment		1405		kHz
LIMITER, AGC, AND FM DEMODULATOR						
t _{OVLD}	Recovery from overload	From 0dBm at input		5	12	μs
	Eb/No	For 12.5% CER		3		dB
	Co-Channel rejection, 12.5% CER	-80 dBm, modulated with 1.536Mbps GFSK, BT=0.5, PRBS data		4		dB
	AM tolerance for 12.5% or better CER	-80 dBm wanted signal, AM modulation depth at 100 KHz rate		90		%
RSSI PERFORMANCE						
t _{RRSSI}	RSSI rise time: < -100dBm to -15dBm into the IF mixer	20 pF load, 20% to 80%	1	5.3	10	μs
t _{FRSSI}	RSSI fall time: <-15dBm to <-100dBm into the IF mixer	20 pF load, 20% to 80%	1	4.4	10	μs
V _{RSMX}	RSSI maximum voltage	-15dBm in	2.2	2.8		V
V _{RSMN}	RSSI minimum voltage	No signal		0.05		V
G _{RSMID}	RSSI sensitivity, mid range		28	35	42	mV/dB
P _{RSMX}	RSSI maximum signal	Sensitivity is >50% mid range		-20		dBm
P _{RSMN}	RSSI minimum signal	Sensitivity is >50% mid range		-95		dBm
	RSSI accuracy	Measured at -40dBm input power	1.5	1.9	2.1	V

TRANSMIT RF BUFFER						
P _{OUT}	Driver amplifier output power	When matched into 50Ω	-4.5	-1.0	+2.0	dBm
	Driver amplifier output return loss	902 to 928 MHz		14		dB
TRANSMIT MODULATION						
f _{DEV}	Modulation Deviation, internal VCO	5 consecutive 1 or 0 bits	400	460	560	kHz
f _{OS}	Modulation center frequency offset	Between 50 μs and 10 ms after PAON high	-100		+100	kHz
TRANSMIT DATA FILTER						
BW _{TX}	Transmit data filter bandwidth	3dB Bandwidth		1.4		MHz
INTERFACE LOGIC LEVELS						
V _{IH}	Input high voltage	never exceed VDD	0.75 * VDD		VDD	V
V _{IL}	Input low voltage				0.25 * VDD	V
I _B	Input bias current		-5	0	5	μA
C _{IN}	Input capacitance	measured at 1MHz		4	6	pF
V _{OH}	DOUT high voltage	Sourcing 0.1 mA Typical value assumes 3.3V VDD	VDD - 0.6	3.08		V
V _{OL}	DOUT low voltage	Sinking 0.1 mA		0.18	0.6	V
INTERFACE TIMING						
t _{RX2PA}	RX to TX switching time	Time from RXON low to PAON high		62.5	70	μs
t _{TX2EN}	TX to RX switching time	Time from RXON high to receiver enabled		72	80	μs
t _{RXEN}	Channel switching time	Time from write to PLL tuning register (EN high) to receiver enabled		320	342	μs
t _{XCEN}	Chip enable time	From XCEN high to receiver enabled with continuous reference applied		320	342	μs

Note 1: Limits are guaranteed by 100% testing, sampling or correlation with worst case test conditions.

PIN DESCRIPTIONS

PIN	SIGNAL NAME	I/O	FUNCTION	DIAGRAM
POWER & GROUND				
8	VSS	I (digital)	Ground for digital I/O circuits and control logic.	
10	RVCC1	O (analog)	DC power supply decoupling point for the PLL dividers, phase detector, and charge pump. This pin is connected to the output of the regulator and to the PLL supplies. There must be a capacitor to ground from this pin to decouple (bypass) noise and to stabilize the regulator.	
12	GND	I (analog)	Ground for the PLL dividers, phase detector, and charge pump.	
13	VCC2	I (analog)	DC Power Supply Input to the VCO voltage regulator. Must be connected to RVCC6 (pin 27) or RVCC7 (pin 29) via decoupling network.	
14	RVCC3	O (analog)	DC power supply decoupling point for the VCO. Connected to the output of the VCO regulator. A capacitor must be tied between this pin and ground to decouple (bypass) noise and to stabilize the regulator.	
16	GND	I (analog)	DC ground for VCO and LO circuits.	
17	GND	I (analog)	Signal ground for RF small signal circuits. Pins 17, 18, and 19 should have short, direct connections to each other and additional connections to ground.	
18	GND	I (analog)	Ground return for the Receive RF input.	
19	GND	I (analog)	Signal ground for the Receive mixers.	
20	GND	I (analog)	DC and Signal ground for the Transmit RF Output buffer.	
22	RVCC4	O (analog)	DC power supply decoupling point for the LO chain. Connected to the output of a regulator. There must be a capacitor to ground from this pin to decouple (bypass) noise and to stabilize the regulator.	
24	VCC5	I (analog)	DC power supply input to voltage Regulators and unregulated loads. VCC5 is the main (or master) analog VCC pin. There must be a capacitor to ground from this pin to decouple (bypass) noise and to stabilize the regulator.	
25	GND	I (analog)	DC ground to IF, Demodulator, and Data Slicer circuits.	
27	RVCC6	O (analog)	DC power supply decoupling point for Quadrature Mixer and IF filter circuits. A capacitor must be tied between this pin and ground to decouple (bypass) noise	

PIN	SIGNAL NAME	I/O	FUNCTION	DIAGRAM
			and to stabilize the regulator.	
29	RVCC7	O (analog)	DC power supply decoupling point for IF, Demodulator, and Data Slicer circuits. A capacitor must be tied between this pin and ground to decouple (bypass) noise and to stabilize the regulator.	
31	VDD	I (digital)	DC power supply input to the interface logic and control registers. This supply is not connected internally to any other supply pin, but its voltage must be less than or equal to the VCC5 supply and greater than 2.7 V. A capacitor must be tied between this pin and ground to decouple (bypass) noise.	

TRANSMIT/RECEIVE

21	RRFI	I (analog)	Receive RF Input. Nominal impedance at 902 to 928 MHz is 17-50j Ω with a simple matching network required for optimum noise figure. This input is to the base of an NPN transistor and should be AC coupled.	
----	------	------------	---	--

PIN	SIGNAL NAME	I/O	FUNCTION	DIAGRAM
23	TRFO	O (analog)	Transmit RF Output. This output is an emitter follower and should be AC coupled.	
DATA				
30	DIN	I (CMOS)	Transmit Data Input. Drives the transmit pulse shaping circuits. Serial digital data on this pin becomes FSK modulation on the Transmit RF output. The logic timing on this pin controls data timing. Internal circuits determine the modulation deviation. This is a standard CMOS input referenced to VDD and VSS.	
32	DOUT	O (CMOS)	Serial digital output after demodulation, chip rate filtering and center data slicing. A CMOS level output (VSS to VDD) with controlled slew rates. A low drive output designed to drive a PCB trace and a CMOS logic input while generating minimal RFI. In digital test modes this pin becomes a test access port controlled by the serial control bus.	

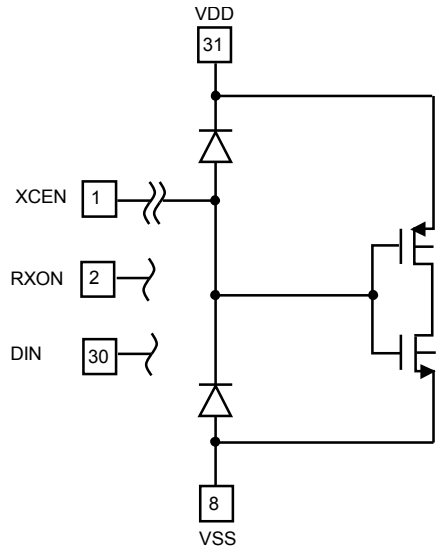
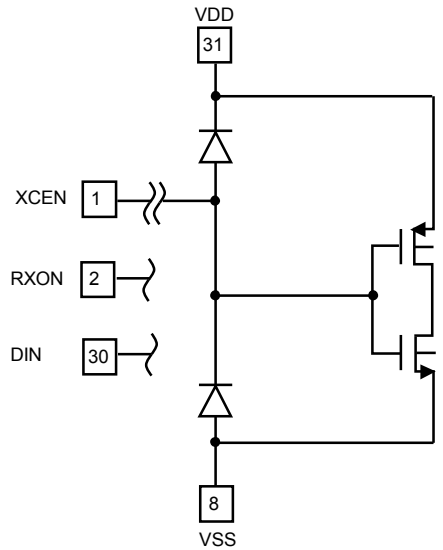
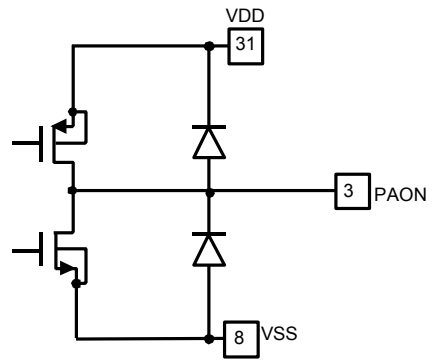
PIN	SIGNAL NAME	I/O	FUNCTION	DIAGRAM
MODE CONTROL AND INTERFACE LINES				
1	XCEN	I (CMOS)	Enables the bandgap reference and voltage regulators when high. With XCEN low the device consumes only leakage current in STANDBY mode when low. XCEN low also preserves register contents and allows register writes. This is a CMOS input, and the thresholds are referenced to VDD and VSS.	
2	RXON	I (CMOS)	Switches the transceiver between TRANSMIT and RECEIVE modes. Circuits are powered up and signal paths reconfigured according to the operating mode. This is a CMOS input, and the thresholds are referenced to VDD and VSS.	
3	PAON	O (CMOS)	Enables the off-chip PA at the correct times in a Transmit slot. Goes high when transmit RF is present at TRFO; goes low 5μs before transmit RF is removed from TRFO. Has interlock logic to shut down the PA if the PLL does not lock.	

PIN	SIGNAL NAME	I/O	FUNCTION	DIAGRAM
7	TPC/TPQ	O (open drain)	Transmit power control output. This open-drain output is pulled low when the TPC bit in serial register #0 is set. Transitions on TPC are synchronized to the falling edge of RXON. In analog test modes, this pin and the RSSI output become test access points controlled by the serial control bus.	
9	REF	I	Input for the 12.288 MHz or 6.144 MHz reference frequency. This input is used as the reference frequency for the PLL and as a calibration frequency for the on-chip filters. This is a self-biased CMOS input that is designed to be driven either by an AC-coupled sine wave.	
11	QPO	O	Charge Pump Output of the phase detector. This is connected to the external PLL loop filter.	

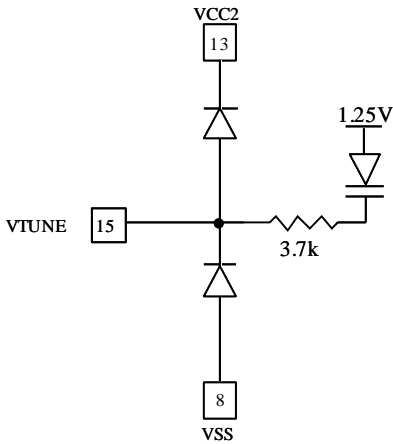
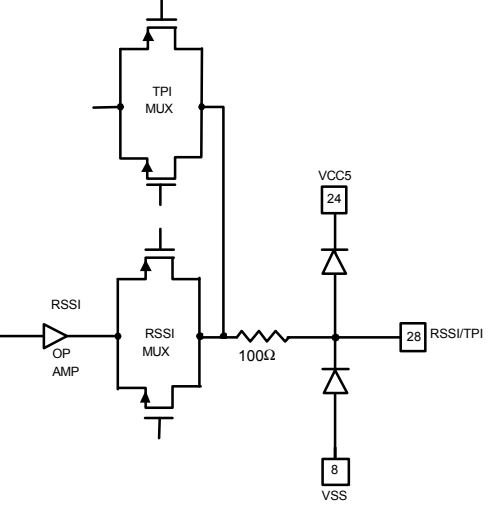
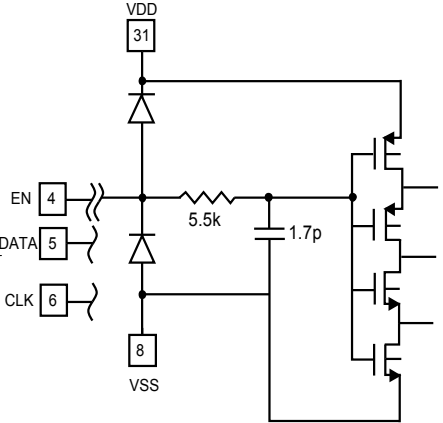
PIN	SIGNAL NAME	I/O	FUNCTION	DIAGRAM
15	VTUNE	I	VCO Tuning Voltage input from the PLL loop filter. This pin is very sensitive to noise coupling and leakage currents.	
26	VBG	O	Internal Bandgap Reference Voltage. Decoupled to ground with a 220nF capacitor.	
28	RSSI/TPI	O	Buffered Analog RSSI output with a nominal sensitivity of 35mV/dB. An RF input signal range of -95 to -20 dBm gives an RSSI voltage output of zero to 2.7 V.	
SERIAL BUS SIGNALS				
4	EN	I (CMOS)	Enable pin for the three-wire serial control bus that sets the operating frequency and programmable options. The control registers are loaded on a low-to-high transition of the signal. Serial control bus data is ignored when this signal is high. This is a CMOS input, and the thresholds are referenced to VDD and VSS.	
5	DATA	I (CMOS)	Serial Control Bus Data. 16-bit words, which include programming data and the two-bit address of a control register. This is a CMOS input, and the thresholds are referenced to VDD and VSS.	
6	CLK	I (CMOS)	Serial control bus data is clocked in on the rising edge when EN is low. This is a CMOS input; the thresholds are referenced to VDD and VSS.	

FUNCTIONAL DESCRIPTION

The ML2722 enables the design and manufacture of low-cost, high-performance FSK transceivers. It can also be used as a 900MHz digital cordless telephone transceiver. Integral to the ML2722 is a low-IF receiver whose LO port is driven from an internal synthesizer. Included are image rejection IF filters, limiters, discriminator, data slicers, and baseband low-pass data filters. It also contains internal voltage regulators to protect critical circuits from power supply noise and transmit modulation circuits.

The ML2722 is designed to transmit and receive 1.536M chips per second in 2.048MHz spaced channels in the 902 to 928MHz ISM band. A single synthesizer is used for both the receiver and the FSK transmitter. The phase locked loop (PLL) is completely integrated, including the voltage controlled oscillator (VCO), tuning circuits, and VCO resonator.

The ML2722 has an internal control interface that programs the synthesizer, the mode of operation, the external LNA and PA, and provides a convenient and flexible interface to various baseband processors. For power level monitoring an RSSI block is included.

In **RECEIVE MODE**, the ML2722 is a single conversion low IF receiver. The demodulation is followed by a matched bit rate filter and a data slicer. The sliced data is provided to a baseband chip for despreading. All channel filtering and demodulation is performed using active filters, which are automatically aligned. A matched bit rate filter and a data slicer follow the demodulator. The sliced data is provided at the DOUT pin.

In **TRANSMIT MODE**, the ML2722 uses the Receive mode VCO and frequency division, with a driver amplifier providing typically -1 dBm output to feed the power amplifier. The PLL frequency synthesizer loop is opened during the transmit time slot, and the VCO is directly modulated by low-pass filtered circuits from the internal modulation filter.

The ML2722 uses multiple voltage regulators to protect sensitive internal circuits from power supply noise. Separate regulators supply the PLL dividers, RF circuits and IF circuits. Each of these regulators takes its power from VCC5, and supplies power internally to its respective RVCCn pin. External capacitors are required at each RVCCn pin to decouple the outputs of the internal regulators. The VCO regulator takes its power from the VCC2 pin which is normally connected to the RVCC6 (pin 27) or RVCC7 (pin 29). An external decoupling capacitor is also used on the internal bandgap voltage reference to improve the noise performance of the regulators.

The integrated PLL frequency synthesizer includes a fully integrated VCO, prescaler, phase detector and charge pump. The reference frequency is generated from the incoming signal at the REF pin, which can be either 6.144MHz or 12.288MHz. The loop filter is external to allow customers to optimize their loop bandwidth to their system's lock time and in-band phase noise requirements. This frequency-agile synthesizer allows the ML2722 to be used in frequency hopped spread spectrum (FHSS) applications with nominal channel spacing of 2.048MHz. Carrier frequency is programmed via the configuration registers and 3-wire serial interface. The VCO tank circuit (inductor and varactor) is fully integrated.

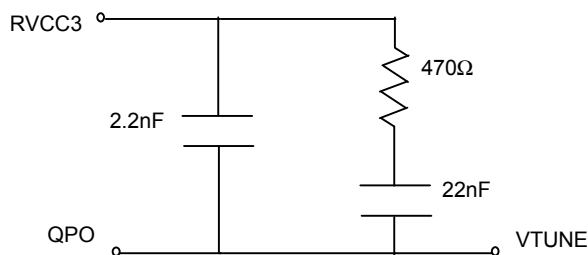

Example 38KHz Loop Filter

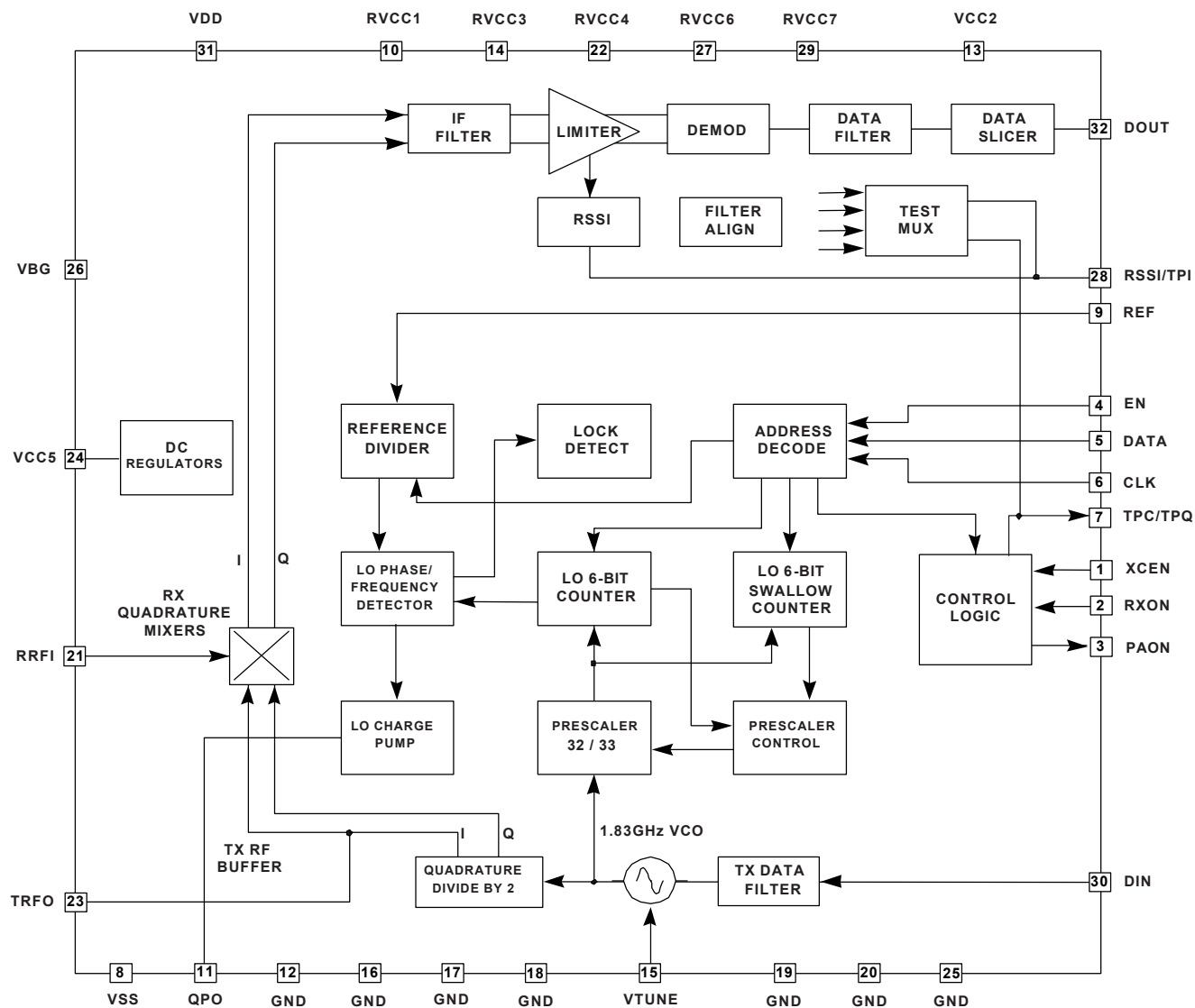

Figure 2. ML2722 Block Diagram

MODES OF OPERATION

OVERVIEW

- **STANDBY:** All circuits powered down, except the control interface (Static CMOS)
- **RECEIVE:** Receiver circuits active
- **TRANSMIT:** PLL open loop, modulated RF output available from the IC

The two operational modes are RECEIVE and TRANSMIT. They are set by the RXON control (pin 2). XCEN (pin 1) is the chip enable/disable and can be set for standby operation. The relationship between the parallel control lines and the mode of operation of the IC is given in Table 1.

XCEN	RXON	MODE	TRANSCEIVER MODE
0	X	STANDBY	Control interfaces active, all other circuits powered down
1	1	RECEIVE	Receiver time slot
1	0	TRANSMIT	Transmit time slot

Table 1: Modes of Operation

MODE CONTROL

The ML2722 is intended for use in TDD and TDMA radios in battery-powered equipment. To minimize power consumption it is designed to switch rapidly from a low power mode (STANDBY) to receive or transmit. The ML2722 can also make a quick transition from receive to transmit for TDD operation. Prior to transmitting or receiving, time should be allowed for the PLL to lock up and for the filters to be aligned. When the ML2722 is operated in single-carrier TDD mode, the LO is automatically shifted by the second (low) IF frequency when the device is switched between RECEIVE and TRANSMIT modes.

ML2722 carrier frequency can be changed (hopped) between transmissions. Carrier frequency (channel) is modified in the ML2722 by writing a corresponding new value to the PLL frequency register.

RECEIVE

The ML2722 uses a single-conversion heterodyne receiver with a nominal IF of 1.024MHz. The signal flow in RECEIVE mode is from the RF input, through an image reject quadrature mixer, limiter, frequency-to-voltage converter, data filter, and data slicer where the digital NRZ data is available at the DOUT pin. A 20dB step AGC extends the dynamic range of the receiver.

The ML2722 receive chain is a Low IF receiver using advanced integrated radio techniques to eliminate external IF filters and minimize external RF filter requirements. The precision filtering and demodulation circuits give improved performance over conventional radio design using external filters while providing integration comparable to advanced direct conversion radio designs.

Receive Signal Strength Indication (RSSI)

RSSI is an indication of field strength. It is typically used to control transmit power to conserve battery life. It may also be used to determine if a given channel is occupied (see Figure 3).

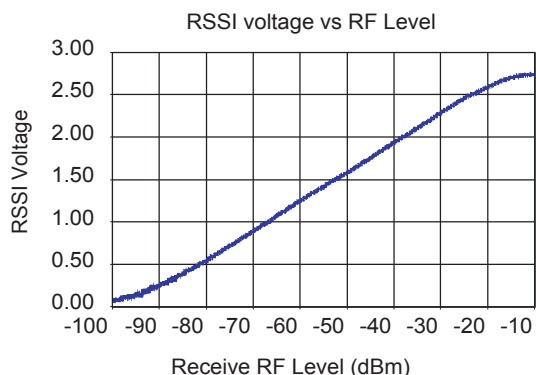

Figure 3. Typical RSSI Response

Automatic Filter Alignment

When the ML2722 is placed in RECEIVE mode, it automatically tunes all the internal filters using the reference frequency from the REF pin. This self-calibration sets:

- Discriminator center frequency
- IF filter center frequency and bandwidth
- Receiver data low-pass filter bandwidth
- Transmit data low pass filter bandwidth

TRANSMIT MODE

In TRANSMIT mode, the VCO is directly modulated with filtered FSK transmit data. The ML2722 transmitter is a 2-FSK transmitter using a directly modulated open loop VCO. The ML2722 design supports transmit time slot lengths up to 10ms, and the time required to set up the transmitter for a new time slot (TXCAL mode) is 62.5 μ s. This type of transmitter is simple, low power, and well suited to a time-time slotted system. The transmitter uses the stored VCO tuning voltage on the PLL loop filter to set the VCO frequency for the duration of the transmitter time slot. The modulation is introduced through a second VCO tuning port. This modulation port has a much lower tuning sensitivity than the main tuning port in order to produce the ± 460 KHz FSK deviation. Compensation circuits stabilize the modulation deviation over the VCO tuning range, and internal logic manages the correct transition from TXCAL to TRANSMIT mode.

The operating cycle of the transmitter starts with the falling edge of RXON. In the first 62.5 μ s after the falling edge of RXON, a calibration mode (TXCAL) is triggered. The data filter input is zeroed and the PLL locks the VCO frequency to the desired RF channel center frequency. A CW signal at the selected RF channel frequency comes out of the Transmit RF output. When the internally generated PLEN control line changes state, the transmitter starts its transition to TRANSMIT mode. The PLL charge pump is disabled, leaving the PLL loop filter to hold the correct tuning voltage for this channel. The data formatter injects an NRZ bipolar data waveform into the Transmit data filter. The Transmit data filter bandlimits this waveform, and feeds it to the modulation compensation circuits. These scale the modulation voltage (depending on the VCO tuning voltage) and drive the VCO tuning port with the scaled, filtered modulation. The voltage on the modulation port swings above and below its central value to produce 2-FSK modulation on the VCO. The modulation filtering is sufficient to meet the FCC occupied bandwidth and out-of-band emissions requirements, and does not introduce significant ISI (Inter Symbol Interference).

The transmit modulation filter is automatically tuned during the first part of every RX and TX time (RXCAL&TXCAL) to remove the need for production alignment. When the chip is first powered up, the tuning information is reset to mid-range. The ML2722 should then be enabled with RXON high. The rising edge on XCEN will trigger a complete calibration of all the on chip filters, which takes 320 μ s. This ensures the modulation filters are aligned to prevent unwanted spurious emissions.

Prior to transmitting the PLL must tune to the intended RF center frequency of the transmission. This occurs in TXCAL mode. The Transmit modulation is disabled and any input on the DIN (pin 30) is ignored. The transmit output buffer is enabled during TXCAL mode. To prevent spurious emissions due to the PLL locking, any external antenna switch or PA should be disabled during TXCAL mode. For optimum performance we recommend that the second harmonic level reflected back into the output TRFO (pin 23), be less than -30dBm .

Phase Locked Loop (PLL) and Channel Selection

The PLL synthesizes channel frequencies to a 512kHz resolution, which is more finely spaced than the 1.536MHz signal bandwidth. Non-overlapping channels are spaced by 2.048MHz where the IF filter and image reject mixer give a typical adjacent channel rejection of 25dB. There are twelve non-overlapping channels in the 902 to 928MHz ISM band (see Table 2).

CHANNEL	FREQUENCY IN MHz
1	903.680
2	905.728
3	907.776
4	909.824
5	911.872
6	913.920
7	915.968
8	918.016
9	920.064
10	922.112
11	924.160
12	926.208

Table 2. Non-Overlapping Channel Frequencies

The LO PLL is programmed via a 3-wire serial control bus. Program words are clocked in on the DATA line (pin 5) by the CLK (pin 6), and loaded into the dividers or control circuits when EN (pin 4) is asserted. There is no check for errors in the program words. Once loaded, register contents are preserved while VDD is present. The register status and operation is independent of the mode of operation of the PLL.

The reference signal from an external crystal oscillator at either 6.144MHz or 12.288MHz is fed to a programmable reference divider. The 1.024MHz reference divider output is fed to the LO phase frequency detector. The PLL prescaler input comes from the VCO at 1.83GHz, so the 1.024MHz comparison frequency gives 512KHz frequency resolution at 902 to 928MHz.

STANDBY MODE

In STANDBY the ML2722 transceiver is powered down. The only active circuits are the control interfaces, which are static CMOS to minimize power consumption. The serial control interface (and control registers) remain powered up and will accept and retain programming data as long as the digital supply is present. The ML2722 serial control registers should be loaded with control and configuration data before any active mode is selected. The filter alignment registers are reset at power up.

TEST MODE

The RF to digital functionality of the ML2722 requires special test mode circuitry for IC production test and radio debugging. A test register, available via the 3-wire serial interface, controls the test multiplexers.

CONTROL INTERFACES

There are two control interfaces: PARALLEL and SERIAL.

PARALLEL INTERFACE

The parallel interface provides immediate control and monitoring of the ML2722. Input signals include:

- **XCEN:** Transceiver enable. Places the ML2722 in Standby or Active (when asserted) modes.
- **RXON:** Receive On. Places an Active ML2722 in Receive mode when asserted.
- **REF:** Reference frequency input

Output signals include:

- **RSSI:** Received Signal Strength Indicator: indicates the power of the received signal
- **PAON:** External Power Amplifier Control Pin

SERIAL INTERFACE

A 3-wire serial interface (EN, DATA, CLK) is used for programming the ML2722 configuration registers, which control device mode, pin functions, PLL and reference dividers, internal test modes, and filter alignment. Data words are entered beginning with the MSB ("big-endian"). The word is divided into a leading 14-bit data field followed by a 2-bit address field. When the address field has been decoded the destination register is loaded on the rising edge of EN. **Providing less than 16 bits of data will result in unpredictable behavior when EN goes high.**

Data and clock signals are ignored when EN is high. When EN is low, data on the DATA pin is clocked into a shift register by rising edges on the CLK pin. The information is latched when EN goes high. This serial interface bus is similar to that commonly found on PLL devices. The data latches are implemented in static CMOS and use minimal power when the bus is inactive. Table 3 and Figure 4 provide timing and register programming illustrations.

SYMBOL	PARAMETER	TIME (ns)
t_R	Clock input rise time	15
t_F	Clock input fall time	15
t_{CK}	Clock period	>50
t_W	Minimum pulse width	2000
t_D	Delay from last clock falling edge	>15
t_{SE}	Enable setup time to ignore next rising clock	>15
t_S	Data-to-clock setup time	>15
t_H	Data-to-clock hold time	>15

Table 3. 3-Wire Bus Timing Characteristics

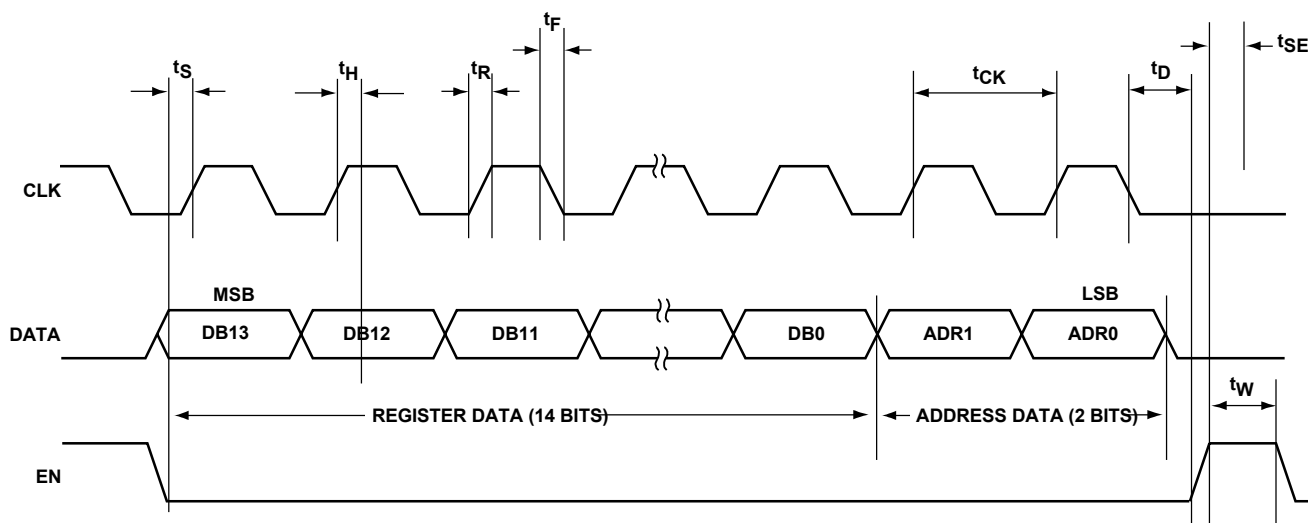

Figure 4. Serial Bus Timing for Address and Data Programming

CONTROL INTERFACES AND REGISTER DESCRIPTIONS

REGISTER INFORMATION

A unidirectional 3-wire serial bus sets the ML2722's transceiver parameters and programs the PLL circuits. Programming is performed by entering 16-bit words into the ML2722 serial interface. Three 16-bit registers are partitioned such that 14 bits are dedicated for data to program the operation and two bits identify the register address.

The three registers are:

- **Register 0:** PLL Configuration
- **Register 1:** Channel Frequency Data
- **Register 2:** Internal Test Access

Figure 5 shows a register map. Table 4 through Table 6 provide detailed diagrams of the register organization: Table 4 and Table 5 outline the PLL configuration and channel frequency registers, and Table 6 displays the filter tuning and test mode register.

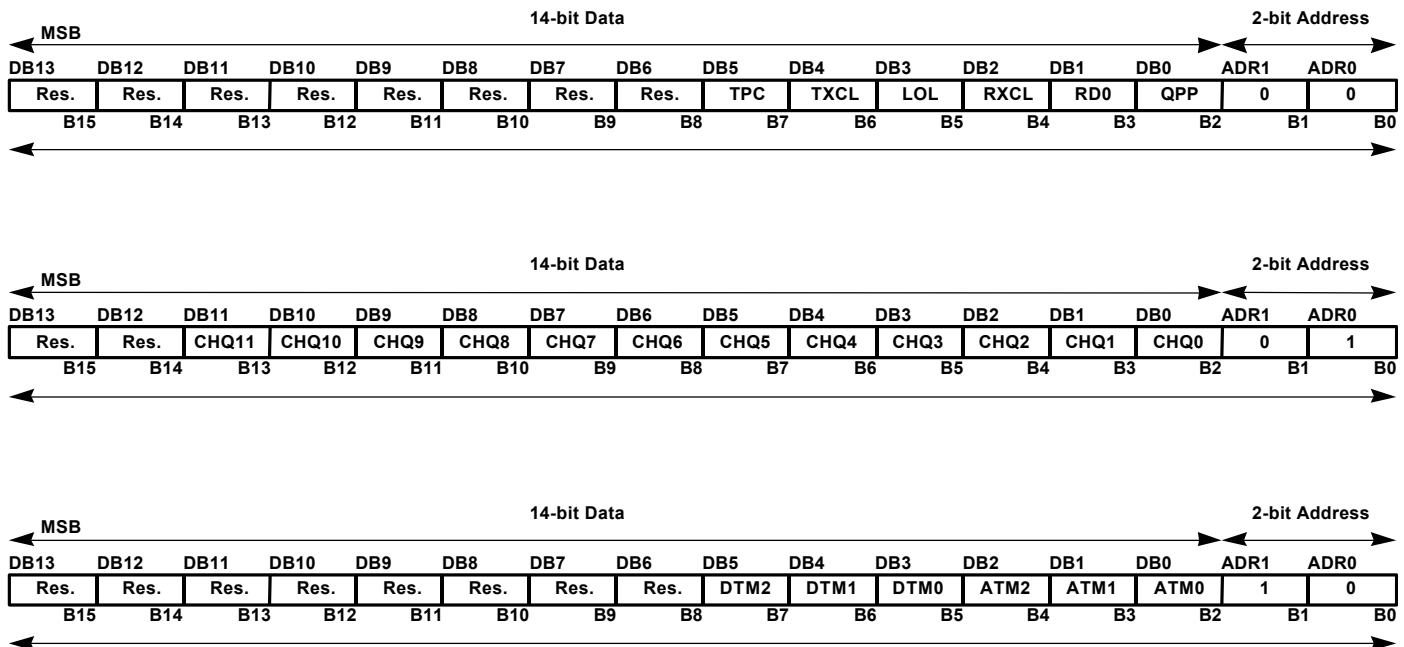

Figure 5. Register Organization

DATA BIT	NAME	DESCRIPTION	USE
B15 (MSB) / DB13	Reserved	Reserved	Set all bits to 0 (zero)
B14 / DB12	Reserved	Reserved	
B13 / DB11	Reserved	Reserved	
B12 / DB10	Reserved	Reserved	
B11 / DB9	Reserved	Reserved	
B10 / DB8	Reserved	Reserved	
B9 / DB7	Reserved	Reserved	
B8 / DB6	Reserved	Reserved	
B7 / DB5	TPC	Transmit Power Control	0: TPC pin high impedance 1: TPC pin pulled to ground
B6 / DB4	TXCL	Transmit Test Mode	0: FSK modulation in Transmit mode 1: CW (no modulation in Transmit mode)
B5 / DB3	LOL	PLL Frequency Shift	0: LO shift is 0 Hz for Transmit, 1.024 MHz for Receive 1: LO shift is 1.024 MHz for Transmit, 0 Hz for Receive
B4 / DB2	RXCL	PLL Mode in Normal Receive Operation	0: PLL open loop during Receive 1: PLL closed loop during Receive
B3 / DB1	RD0	Reference Frequency Select	0: 6.144MHz nominal reference frequency 1: 12.288MHz nominal reference frequency
B2 / DB0	QPP	PLL Charge Pump Polarity	0: Freq. sig. < freq. ref.; Charge pump sources current 1: Freq. sig. < freq. ref.; Charge pump sinks current
B1 / ADB1	ADR1	MSB Address Bit	ADR1 = 0
B0 (LSB) / ADB0	ADR0	LSB Address Bit	ADR0 = 0

Table 4. Register 0 -- PLL Configuration Register

DATA BIT	NAME	DESCRIPTION	USE
B15 (MSB) / DB13	Reserved	Channel Frequency select bits	Set all bits to 0 (zero)
B14 / DB12	Reserved		
B13 / DB11	CHQ11		Divide ratio = $f_c / 0.512$
B12 / DB10	CHQ10		
B11 / DB9	CHQ9		
B10 / DB8	CHQ8		
B9 / DB7	CHQ7		
B8 / DB6	CHQ6		
B7 / DB5	CHQ5		
B6 / DB4	CHQ4		
B5 / DB3	CHQ3		
B4 / DB2	CHQ2		
B3 / DB1	CHQ1		
B2 / DB0	CHQ0		
B1 / ADB1	ADR1	MSB Address Bit	ADR1 = 0
B0 (LSB) / ADB0	ADR0	LSB Address Bit	ADR0 = 1

Table 5. Register 1 – Channel Frequency Register

DATA BIT	NAME	DESCRIPTION	USE
B15 (MSB) / DB13	Reserved	Reserved	Set all bits to 0 (zero)
B14 / DB12	Reserved		
B13 / DB11	Reserved		
B12 / DB10	Reserved		
B11 / DB9	Reserved		
B10 / DB8	Reserved		
B9 / DB7	Reserved		
B8 / DB6	Reserved		
B7 / DB5	DTM2	Digital Test Control Bits	See Table 15
B6 / DB4	DTM1		
B5 / DB3	DTM0		
B4 / DB2	ATM2	Analog Test Control Bits	See Table 14
B3 / DB1	ATM 1		
B2 / DB0	ATM 0		
B1 / ADB1	ADR1	MSB Address Bit	ADR1 = 1
B0 (LSB) / ADB0	ADR0	LSB Address Bit	ADR0 = 0

Table 6. Register 2 – Test Mode Register

CONTROL REGISTER DESCRIPTIONS

Power-On State

All register values are set to 0 (zero) on Power Up. Power up is defined as occurring when VDD (pin 31) = 2.0V (typical). The register default values are valid after power up. The PLL divide ratio and PLL configuration registers must be programmed before XCEN is asserted for the first time.

Address and Data Bits (ADR)

Each of the three registers are identically configured. Each is divided into a fourteen (14) bit data field and a two (2) bit address field. The 16 bits are input serially (see Figure 5) with the 14 data bits, most significant bit (DB13) first followed by the two address bits, most significant bit (ADR1) first. The last 16 bits clocked into the ML2722 will be loaded into the specified register. Loading less than 16 bits into any register will cause unpredictable device functionality.

RES Bit Locations (Reserved)

Bits identified as reserved must always have a logic 0 (zero) value for correct device operation. Power-on reset clears all reserved bits to zero. Each reserved bit must be programmed to logic zero whenever any of the three registers are reprogrammed.

REGISTER #0, PLL CONFIGURATION

PLL Charge Pump Polarity (QPP): DB0

This bit sets the charge pump polarity to sink or source current. For a majority of applications, this bit is cleared (QPP = 0). For applications where an external amplifier is in the loop filter, this bit is set to 1 to change the charge pump polarity (see Table 7).

QPP	PLL CHARGE PUMP POLARITY
0	Frequency signal < frequency reference. Charge pump sources current.
1	Frequency signal < frequency reference. Charge pump sinks current.

Table 7. PLL Charge Pump Polarity

Reference Divide Bit Zero (RD0): DB1

This bit sets the reference division of the PLL to either 6 or 12 (see Table 8).

RD0	REFERENCE DIVISION	NOMINAL REFERENCE FREQUENCY
0	6	6.144 MHz
1	12	12.288 MHz

Table 8. Reference Frequency Select

Receive Closed Loop Bit (RXCL): DB2

This bit is used in Receive mode to put the PLL into either open loop or closed loop (see Table 9).

RXCL	RECEIVE PLL MODE
0	PLL open loop
1	PLL closed loop

Table 9. PLL Mode in Normal Receive Operation

PLL Frequency Shift Bit (LOL): DB3

LO shift for transmit and receive. For normal operations, it is recommended that LOL = 0 (see Table 10).

LOL	LO SHIFT FOR TRANSMIT	LO SHIFT FOR RECEIVE
0	0	+1.024 MHz
1	+1.024 MHz	0

Table 10. PLL Frequency Shift

Transmit Closed Loop Bit (TXCL): DB4

Used to produce a continuous CW transmitter output for product test with RXON low (see Table 11).

TXCL	TRANSMIT PLL MODE
0	PLL Open Loop, FSK Output
1	PLL Closed Loop, CW Output

Table 11. PLL Mode in Transmit Operation

Transmit Power Control Bit (TPC): DB5

Controls the state of the TPC/TPQ open-drain output (pin 7). Although this bit may be set at any time, the TPC/TPQ pin only changes state at the falling edge of RXON (see Table 12).

TPC	TPC PIN STATE
0	High Impedance
1	Pulled to Ground

Table 12. TPC Pin State

REGISTER #1, CHANNEL FREQUENCY REGISTER

Channel Frequency Selection Bits (CHQ): <DB11:DB0>

These bits set the channel frequency for the transceiver (see Table 13). With a 6.144MHz or 12.288MHz input to the REF pin (pin 9), the channel frequency value is calculated by multiplying the CHQ value by 0.512. A 1.024MHz offset is automatically added in the RECEIVE mode to accommodate the IF frequency. The recommended operating range value of the CHQ is from 1,024 (400 hex) to 4093 (FFD hex). These bits should be programmed to a valid channel frequency before XCEN is asserted. The divide ratio is calculated as $f_c / 0.512$, where f_c is the channel frequency in MHz.

B15	B14	B13 TO B2	B1	B0
0	0	PLL divide ratio	0	1

Table 13. Main Divider

REGISTER #2, FILTER TUNING SELECT TEST MODE

Analog Test Control Bits (ATM): <DB2:DB0>

The test mode selected is described in Table 14. The performance of the ML2722 is not specified in these test modes. Although primarily intended for IC test and debug, they also can help in debugging the radio system. The default (power-up) state of these bits is ATM<2:0> = <0,0,0>. When a non-zero value is written to the field, RSSI/TPI (pin 28) and TPC/TPQ (pin 7) become analog test access ports, giving access to the outputs of key signal processing stages in the transceiver. During normal operation, the ATM field should be set to zero.

ATM2	ATM1	ATM0	RSSI/TPI	TPC/TPQ
0	0	0	RSSI	TPC (PA Control)
0	0	1	I No Connect	Q No Connect
0	1	0	I IF Buffer Output	Q IF Buffer Output
0	1	1	I IF Buffer Output	Q IF Buffer Output
1	0	0	I IF Buffer Output	Q IF Buffer Output
1	0	1	I Data Slicer Input	Q Data Slicer Input
1	1	0	I IF Limiter Outputs	Q IF Limiter Outputs
1	1	1	1.67V Ref.	VCO Mod. Voltage

Table 14. Analog Test Control Bits

Digital Test Control Bits (DTM): <DB2:DB0>

The DTM<2:0> bit functions are described in Table 15. The performance of the ML2722 is not specified in these test modes. Although primarily intended for IC test and debug, they also can help in debugging the radio system. The default (power-up) state of these bits is DTM<2:0> = <0,0,0>. When a non-zero value is written to these fields, DOUT (pin 32) becomes a digital test access port for key digital signals in the transceiver. During normal operation, the DTM field should be set to zero.

DTM2	DTM1	DTM0	DOUT
0	0	0	Demodulated data
0	0	1	Receiver AGC state
0	1	0	PLL Main Divider Output
0	1	1	PLL Reference Divider Output

Table 15. Digital Test Control Bits

TRANSMIT AND RECEIVE DATA INTERFACES

The DIN and DOUT CMOS logic levels are serial data that correspond to FSK modulated data on the radio channel. The ML2722 operates as an FSK transceiver in the 902 to 928MHz ISM band. The chip rate, bit rate and spreading code are controlled by the baseband processor, and the FM deviation and transmit filtering are controlled by the transceiver.

DIN provides data to the Transmit data filter, which band limits the transmitted chips or bits before they are FM modulated. There is no re-timing of the chips or bits, so the transmitted FSK chips or bits take their timing from DIN (pin 30). In the Receive chain, FM demodulation, data filtering, and data slicing take place in the ML2722 receiver, with chip, bit and word rate timing recovery performed in the baseband processor.

RSSI AND REF

There are two other interface pins between the ML2722 transceiver and the baseband IC: the RSSI/TPI (pin 28) and REF (pin 9).

REF is the master reference frequency for the transceiver. It supplies the frequency reference for the RF channel frequency and the filter tuning. The REF pin is a CMOS input with internal biasing resistors. It can be AC coupled through a 470pF coupling capacitor to a sine wave source of at least 2.0V peak-to-peak. The PLL comparison and the IF filter center frequency are both equal to the REF input frequency divided by either 6 or 12, depending on the setting of the RDIV bit in the PLL configuration control word. The IF filter and data filter bandwidths track the IF filter center frequency.

The Received Signal Strength Indicator (RSSI) pin supplies a voltage indicating the amplitude of the received RF signal. It is normally connected to the input of a low-speed ADC on an external baseband IC, and is used during channel scanning to detect clear channels on which the radio may transmit. The RSSI voltage is proportional to the logarithm of the received power level. A voltage of 0V to 2.7V typically corresponds to an RF input power of -95 to -20dBm with a nominal slope of 35mV/dB.

CONTROL OUTPUTS TO THE PA – PAON AND TPC

The ML2722 has two output pins to control and sequence the power amplifier – PAON and TPC (see Figure 6).

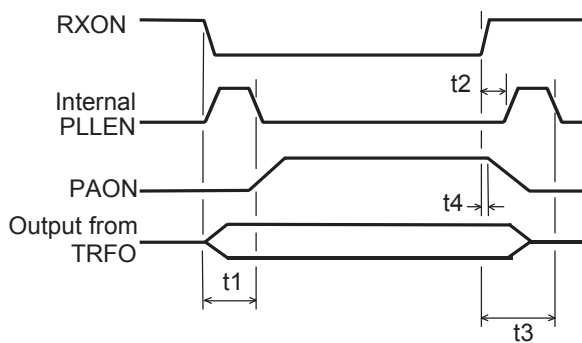

SYMBOL	PARAMETER	TIME/mS
t1	RXON falling edge to PAON rising edge	62.5
t2	RXON rising edge to PLL recalibration	6.5
t3	RXON rising edge to receive mode	70
t4	RXON rising edge to PAON falling edge	< 0.1

Figure 6. Power Amplifier Interface

The PAON (PA control) is a CMOS output to control an off-chip RF PA (power amplifier). It outputs a logic high when the PA should be enabled, and a logic low at all other times. This output is inhibited if the PLL fails to lock, or the power supply to the ML2722 falls below 2.6V. The PLL lock detect or low voltage signals are latched, so that the transmitter is inhibited for the entire transmit time slot. These latches are reset at the end of the transmit time slot, so that the ML2722 will transmit in the next time slot following a transient fault condition.

The TPC/TPQ (pin 7) is an open drain output intended for transmit power control. It is controlled by the TPC bit in serial bus register 0. This bit can be changed at any time, but the TPC pin will not change state until the beginning of the next transmit time slot, triggered by a falling edge on RXON. This pin interfaces to an external PA power control input via a resistor network to set the output power level.

In analog test modes the RSSI/TPI (pin 28) and TPC/TPQ (pin 7) become analog test access ports that allow the user to observe internal signals in the ML2722.

RF INTERFACES

The RRFI receive input (pin 21) and the TRFO transmit output (pin 23) are the only RF I/O pins. The RRFI pin requires a simple impedance matching network for best input noise figure, and the TRFO pin is matched to 50Ω by an AC coupling capacitor. The associated RF input and output ground pins must have direct connections to an RF ground plane, and the RF block supply pins must be well decoupled to the RF ground pins.

f	S ₁₁	
	MAG	ANGLE
0.9	0.757	-83.0

RRFI S-PARAMETERS AT 3.3 V, OPERATING TEMPERATURE 25°C

Table 16. Typical Receive RF Input

f	S ₁₁	
	MAG	ANGLE
0.9	0.208	139.5

TRFO S-PARAMETERS AT 3.3 V, OPERATING TEMPERATURE 25°C

Table 17. Typical Transmit RF Output

PHYSICAL DIMENSIONS (INCHES/MILLIMETERS)

Package:
32-Pin (7 x 7 x 1mm)

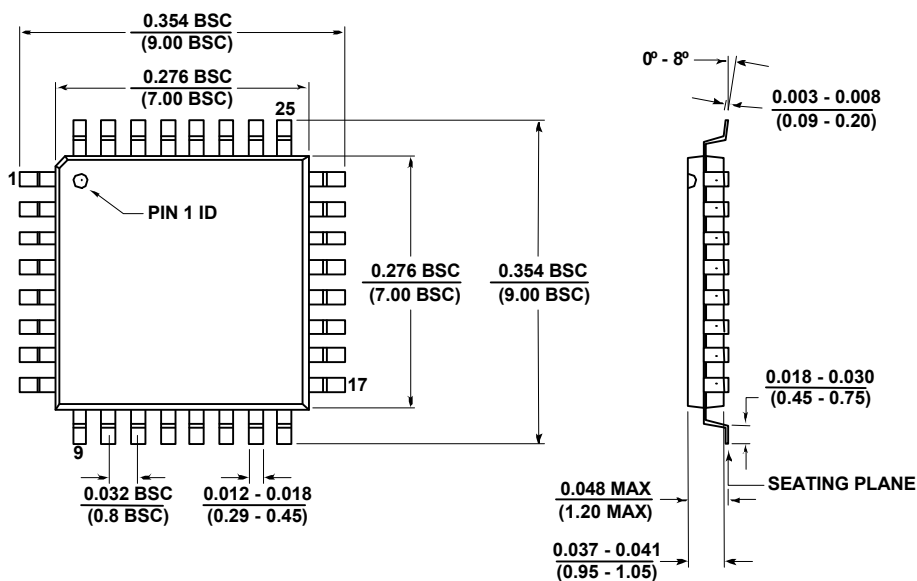

Leads cannot exceed $\frac{0.004}{(0.102)}$ maximum coplanarity

ORDERING INFORMATION

PART NUMBER	TEMPERATURE RANGE	PACKAGE	PUBLICATION
ML2722DH	-10°C to 60°C	32 Pin TQFP 7mm body	DS2722-F-04

WARRANTY

Micro Linear makes no representations or warranties with respect to the accuracy, utility, or completeness of the contents of this publication and reserves the right to make changes to specifications and product descriptions at any time without notice. No license, express or implied, by estoppel or otherwise, to any patents or other intellectual property rights is granted by this document. The circuits contained in this document are offered as possible applications only. Particular uses or applications may invalidate some of the specifications and/or product descriptions contained herein. The customer is urged to perform its own engineering review before deciding on a particular application. Micro Linear assumes no liability whatsoever, and disclaims any express or implied warranty, relating to sale and/or use of Micro Linear products including liability or warranties relating to merchantability, fitness for a particular purpose, or infringement of any intellectual property right. Micro Linear products are not designed for use in medical, life saving, or life sustaining applications.

If this document is "Advance", its contents describe a Micro Linear product that is currently under development. All detailed specifications including pinouts and electrical specifications may be changed without notice. If this document is "Preliminary", its contents are based on early silicon measurements. Typical data is representative of the product but is subject to change without notice. Pinout and mechanical dimensions are final. Preliminary documents supersede all Advance documents and all previous Preliminary versions. If this document is "Final", its contents are based on a characterized product, and it is believed to be accurate at the time of publication. Final Data Sheets supersede all previously published versions. This document is Final.

© 2003 Micro Linear Corporation. All rights reserved. All other trademarks are the property of their respective owners.

Products described herein may be covered by one or more of the following U.S. patents: 4,897,611; 4,964,026; 5,027,116; 5,281,862; 5,283,483; 5,418,502; 5,508,570; 5,510,727; 5,523,940; 5,546,017; 5,559,470; 5,565,761; 5,592,128; 5,594,376; 5,652,479; 5,661,427; 5,663,874; 5,672,959; 5,689,167; 5,714,897; 5,717,798; 5,742,151; 5,747,977; 5,754,012; 5,757,174; 5,767,653; 5,777,514; 5,793,168; 5,798,635; 5,804,950; 5,808,455; 5,811,999; 5,818,207; 5,818,669; 5,825,165; 5,825,223; 5,838,723; 5,844,378; 5,844,941. Japan: 2,598,946; 2,619,299; 2,704,176; 2,821,714. Other patents are pending.



Micro Linear Corporation
2050 Concourse Drive
San Jose, CA 95131
Tel: (408) 433-5200
Fax: (408) 432-0295
www.microlinear.com