

IC for DC Motor Control

Monolithic IC MM1038

Outline

This IC is used to control the revolution rate of motors which can be controlled by low voltages. It can be used to configure a high-precision FG motor using few external components. In particular, a unique new circuit design with improved low-voltage operating characteristics enables configuration of sets such as headphone stereos with auto-reverse functions which are unaffected by power supply voltage drops when the motor is reversed, making them ideal for speed control of low-voltage DC motors.

Features

1. Operation at low voltages possible
2. Broad power supply voltage range
3. Small input current
4. Few external components, small package
5. Speed is easily changed over a wide range; accommodates two-speed operation

Package

- SOP-8A (MM1038AF)
- SOP-8D (MM1038CF)

Absolute Maximum Ratings

Item	Symbol	Ratings		Units
Operating temperature	T _{OPR}	-10~+60		°C
Storage temperature	T _{STG}	-30~+125		°C
Power supply current	V _{CC}	-0.3~10		V
Output current	I _L	700		mA
Power consumption I *1	Pd I	Ta=25°C 340	Ta=40°C 290	mW
Power consumption II *2	Pd II	Ta=25°C 690	Ta=40°C 580	mW

*1: Power consumption I : Unit

*2: Power consumption II : when mounted on board

(55.0×20.0 mm, t=0.8 mm, copper area 30%)

Electrical Characteristics (Except where noted otherwise, Ta=25°C)

Item	Symbol	Measurement conditions	Min.	Typ.	Max.	Units
Consumption current	I_d	A1		1.75	4.0	mV
Startup current	I_{MS}	A2 when R_v is 1.5Ω	500			mV
Reference voltage	V_S	A1 when SW1 is off	90	100	110	mV
Reference voltage fluctuation I	$\Delta VS1$	VS fluctuation rate for V_{CC} between 1.5 and 3.5 V with $V_{CC}=3.0$ V as reference		0.1	0.5	%/V
Reference voltage fluctuation II	$\Delta VS2$	VS fluctuation rate for I_M between 25 and 200 mA with $I_M=100$ mA as reference		0.05	0.05	%/mA
Reference voltage fluctuation III	$\Delta VS3$	VS fluctuation rate for T_a between -10 and as reference 60 °C with $T_a=25^\circ\text{C}$		0.01		%/°C
Output saturation voltage	V_{oSAT}	V2 SW2 on, when I_M is 200mA		0.2	0.3	V
Bridge ratio	K	V_4/V_3	9.5	10	10.5	
Bridge ratio fluctuation I	$\Delta K1$	K fluctuation rate for V_{CC} between 1.5 and 3.5 V with $V_{CC}=3.0$ V as reference		0.1	0.2	%/V
Bridge ratio fluctuation II	$\Delta K2$	K fluctuation rate for I_M between 25 and 200 mA with $I_M=100$ mA as reference		0.01	0.06	%/mA
Bridge ratio fluctuation III	$\Delta K3$	K fluctuation rate for T_a between -10 and 60 °C with $T_a=25^\circ\text{C}$ as reference		0.01		%/°C

Measurement conditions: Except where noted otherwise, $V_{CC}=3.0$ V, $I_M=100$ mA, SW1=on, SW2=off

Block Diagram

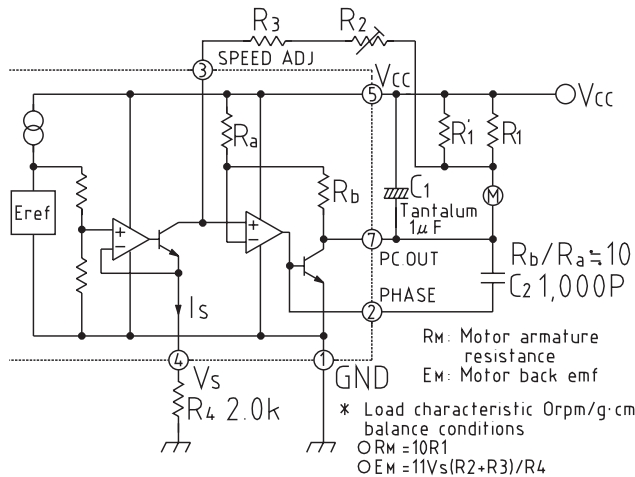

Measuring Circuit

