



1/3-INCH SOC MEGAPIXEL CMOS DIGITAL IMAGE SENSOR

MT9M111I29STC

(Micron Part Number)

Features

- DigitalClarity CMOS Imaging Technology
- System-on-a-Chip (SOC)—Completely integrated camera system
- Ultra-low power, low cost, progressive scan CMOS image sensor
- Superior low-light performance
- On-chip image flow processor (IFP) performs sophisticated processing:
Color recovery and correction
Sharpening, gamma, lens-shading correction
On-the-fly defect correction
- Filtered image downscaling to arbitrary size with smooth, continuous zoom and pan
- Automatic Features:
Auto exposure, auto white balance (AWB), auto black reference (ABR), auto flicker avoidance, auto color saturation, auto defect identification and correction
- Fully automatic Xenon and LED-type flash support
Fast exposure adaptation
- Multiple parameter contexts
Easy/fast mode switching
- Camera control sequencer automates:
Snapshots
Snapshots with flash
Video clips
- Simple two-wire serial programming interface
- ITU-R BT.656 (YCbCr), 565RGB, 555RGB, or 444RGB formats (progressive scan)
- Raw and processed Bayer formats
- Output FIFO and integer clock divider:
“Uniform” pixel clocking

Applications

- Cellular phones
- PDAs
- Toys
- Other battery-powered products

Table 1: Key Performance Parameters

PARAMETER		TYPICAL VALUE
Optical Format		1/3-inch (5:4)
Active Imager Size		4.6mm(H) x 3.7mm (V), 5.9mm diagonal
Active Pixels		1,280H x 1,024V
Pixel Size		3.6 μ m x 3.6 μ m
Color Filter Array		RGB Bayer Pattern
Shutter Type		Electronic Rolling Shutter (ERS)
Maximum Data Rate/ Maximum Master Clock		27 MPS/54 MHz
Frame Rate	SXGA (1,280 x 1,024)	15 fps at 54 MHz
	QXSGA (640 x 512)	30 fps at 54 MHz
ADC Resolution		10 bit, dual on-chip
Responsivity		1.0 V/lux-sec (550nm)
Dynamic Range		71dB
SNR _{MAX}		44dB
Supply Voltage	I/O Digital	1.7V–3.6V
	Core Digital	2.5V–3.1V
	Analog	2.5V–3.1V
Power Consumption		170mW SXGA at 15 fps (54 MHz CLKIN)
		90mW QXSGA at 30 fps (54 MHz low-power mode)
Operating Temperature		-30°C to +70°C
Packaging		44-Ball iCSP wafer or die



Table of Contents

Features	1
Applications	1
General Description	6
Functional Overview	7
Internal Architecture	7
Register Notation	7
Typical Connections	9
Architecture Overview	12
Sensor Core	12
Lens-Shading Correction and Black Level Conditioning	12
Defect Correction	12
Interpolation, Aperture, and Color Correction	12
Resize	12
Camera Control	12
Camera Interface and Test Patterns	12
Contexts, Snapshots, and Flash	13
Output Data Ordering	14
IFP Register List	15
IFP Register Description	22
Configuration	22
Sensor Core Overview	34
Pixel Data Format	34
Pixel Array Structure	34
Output Data Format	35
Sensor Core Register List	36
Sensor Core Register Descriptions	39
Sensor Read Modes and Timing	45
Contexts	45
Viewfinder/Preview and Full-Resolution/Snapshot Modes	45
Low-Power Preview Mode	45
Full-Resolution Snapshot Mode	45
Switching Modes	45
Clocks	45
Primary Operating Modes	46
Full-Power Readout Mode	46
Low-Power Readout Mode	47
Tuning Frame Rates	47
Default Blanking Calculations	47
[REG<a> REG]:	47
User Blanking Calculations	48
Exposure and Sensor Context Switching	49
Exposure	49
Switching From Context A to B	49
Horizontal Blanking	49
Switching Modes	49
Switching Frequency	49
Simple Snapshots	49
Output Timing	50
Typical Resolutions, Modes and Timing	51
Reset, Clocks, and Standby	51
Functional Operation	51



Electrical Specifications52
Power Consumption53
I/O Timing54
APPENDIX A56
Serial Bus Description56
Protocol56
Sequence56
Bus Idle State56
Start Bit56
Stop Bit56
Slave Address56
Data Bit Transfer56
Acknowledge Bit56
No-Acknowledge Bit56
Two-Wire Serial Interface Sample57
Write and Read Sequences (SADDR = 1)57
16-Bit Write Sequence57
16-Bit Read Sequence57
8-Bit Write Sequence58
8-Bit Read Sequence58
Two-Wire Serial Bus Timing58
Data Sheet Designation: Preliminary60
Revision History61



List of Figures

Figure 1:	Functional Block Diagram	8
Figure 2:	Internal Registers Grouping	8
Figure 3:	Typical Configuration (Connection)	9
Figure 4:	44-Ball iCSP Assignment	10
Figure 5:	Sensor Core Block Diagram	34
Figure 6:	Pixel Array Description	34
Figure 7:	Pixel Color Pattern Detail (Top Right Corner)	34
Figure 8:	Spatial Illustration of Image Readout	35
Figure 9:	Primary Sensor Core Clock Relationships	46
Figure 10:	Vertical Timing	50
Figure 11:	Horizontal Timing	50
Figure 12:	I/O Timing Diagram	54
Figure 13:	Spectral Response Chart (Preliminary)	55
Figure 14:	Optical Center Diagram	55
Figure 15:	Write Timing to R0x09:0—Value 0x0284	57
Figure 16:	Read Timing from R0x09:0; Returned Value 0x0284	57
Figure 17:	Write Timing to R0x09:0—Value 0x0284	58
Figure 18:	Read Timing from R0x09:0; Returned Value 0x0284	58
Figure 19:	Serial Host Interface: Start Condition Timing	59
Figure 20:	Serial Host Interface: Stop Condition Timing	59
Figure 21:	Serial Host Interface Write	59
Figure 22:	Serial Host Interface Read	59
Figure 23:	Acknowledge Signal Timing After an 8-Bit Write to Sensor	59
Figure 24:	Acknowledge Signal Timing After an 8-Bit Read from Sensor	59
Figure 25:	44-Ball iCSP Package	60



List of Tables

Table 1:	Key Performance Parameters	1
Table 2:	Pin Descriptions	10
Table 3:	Data Ordering in YCbCr Mode	14
Table 4:	Output Data Ordering in Processed Bayer Mode	14
Table 5:	Output Data Ordering in RGB Mode	14
Table 6:	Output Data Ordering in (8 + 2) Bypass Mode	14
Table 7:	Colorpipe Registers (Address Page 1)	15
Table 8:	Camera Control Registers (Address Page 2)	17
Table 9:	Colorpipe Register Description	22
Table 10:	Camera Control Register Description	30
Table 11:	Sensor Registers (Address Page 0)	36
Table 12:	Sensor Core Register Descriptions	39
Table 13:	Register Address Functions	47
Table 14:	Blanking Parameter Calculations	48
Table 15:	User Blanking Minimum Values	48
Table 16:	Blanking Definitions	51
Table 17:	Electrical Characteristics and Operating Conditions	52
Table 18:	I/O Parameters	52
Table 19:	Power Consumption at 2.8V	53
Table 20:	I/O Timing Table	54



General Description

The Micron® Imaging MT9M111 is an SXGA-format single-chip camera with a 1/3-inch CMOS active-pixel digital image sensor. This device combines the MT9M011 image sensor core with fourth-generation digital image flow processor technology from Micron Imaging. It captures high-quality color images at SXGA resolution.

The MT9M111 features DigitalClarity, Micron's breakthrough, low-noise CMOS imaging technology that achieves CCD image quality (based on signal-to-noise ratio and low-light sensitivity) while maintaining the inherent size, cost and integration advantages of CMOS.

The sensor is a complete camera-on-a-chip solution designed specifically to meet the low-power, low-cost demands of battery-powered products such as cellular phones, PDAs, and toys. It incorporates sophisticated camera functions on-chip and is programmable through a simple two-wire serial interface.

The MT9M111 performs sophisticated processing functions including color recovery, color correction, sharpening, programmable gamma correction, auto black reference clamping, auto exposure, automatic 50Hz/60Hz flicker avoidance, lens-shading correction,

auto white balance (AWB), and on-the-fly defect identification and correction. Additional features include day/night mode configurations; special camera effects such as sepia tone and solarization; and interpolation to arbitrary image size with continuous filtered zoom and pan. The device supports both Xenon and LED-type flash light sources in several snapshot modes.

The MT9M111 can be programmed to output progressive-scan images up to 30 frames per second (fps) in preview power-saving mode, and 15 fps in full-resolution (SXGA) mode. In either mode, the image data can be output in any one of six 8-bit formats:

- ITU-R BT.656 (formerly CCIR656, progressive scan only) YCbCr
- 565RGB
- 555RGB
- 444RGB
- Raw Bayer
- "Processed" Bayer

The FRAME_VALID and LINE_VALID signals are output on dedicated pins, along with a pixel clock that is synchronous with valid data.



Functional Overview

The MT9M111 is a fully-automatic, single-chip camera, requiring only a power supply, lens and clock source for basic operation. Output video is streamed via a parallel 8-bit DOUT port, shown in Figure 1 on page 8. The output pixel clock is used to latch data, while FRAME_VALID and LINE_VALID signals indicate the active video. The MT9M111 internal registers are configured using a two-wire serial interface.

The device can be put in low-power sleep mode by asserting the standby pin and shutting down the clock. Output pins can be tri-stated by de-asserting the OE# pin. Both tri-stating output pins and entry in standby mode also can be achieved via two-wire serial interface register writes.

The MT9M111 accepts input clocks up to 54 MHz, delivering up to 15 fps for SXGA resolution images, and up to 30 fps for QSXGA (full field-of-view, sensor pixel skipping) images. The device also supports a low-power preview configuration that delivers SXGA images at 7.5 fps and QSXGA images at 30 fps. The device can be programmed to slow the frame rate in low-light conditions to achieve longer exposures and better image quality.

Internal Architecture

Internally, the MT9M111 consists of a sensor core and an IFP. The IFP is divided in two sections: the colorpipe (CP), and the camera controller (CC). The sensor core captures raw Bayer-encoded images that are then input in the IFP. The CP section of the IFP processes the incoming stream to create interpolated, color-corrected output, and the CC section controls the sensor core to maintain the desired exposure and color balance, and to support snapshot modes. The sensor core, CP, and CC registers are grouped in three

separate address spaces, shown in Figure 2. When accessing internal registers via the two-wire serial interface, select the desired address space by programming the R240 shared register.

The MT9M111 accelerates mode switching with hardware-assisted context switching, and supports taking snapshots, flash snapshots, and video clips using a configurable sequencer.

The MT9M111 supports a range of color formats derived from four primary color representations: YCbCr, RGB, raw Bayer (unprocessed, directly from the sensor), and processed Bayer (Bayer format data regenerated from processed RGB). The device also supports a variety of output signaling/timing options:

- Standard FRAME_VALID/LINE_VALID video interface with gated pixel clocks
- Standard video interface with uniform clocking
- ITU-R BT.656 marker-embedded video interface with either gated or uniform pixel clocking.

Register Notation

The following register address notations are used in this document:

- R<decimal address>:<address page>
Example: R9:0—Shutter width register in sensor page (page 0). Used to uniquely specify a register.
- R<decimal address>
Example: R240—Page address register. Used when the register address is the same in all three pages or when by context the address page is understood.
- 0x<2 digit hex address>
Example: 0xF0—Page address register. Used when the register address is the same in all three pages, or when by context the address page is understood.

Figure 1: Functional Block Diagram

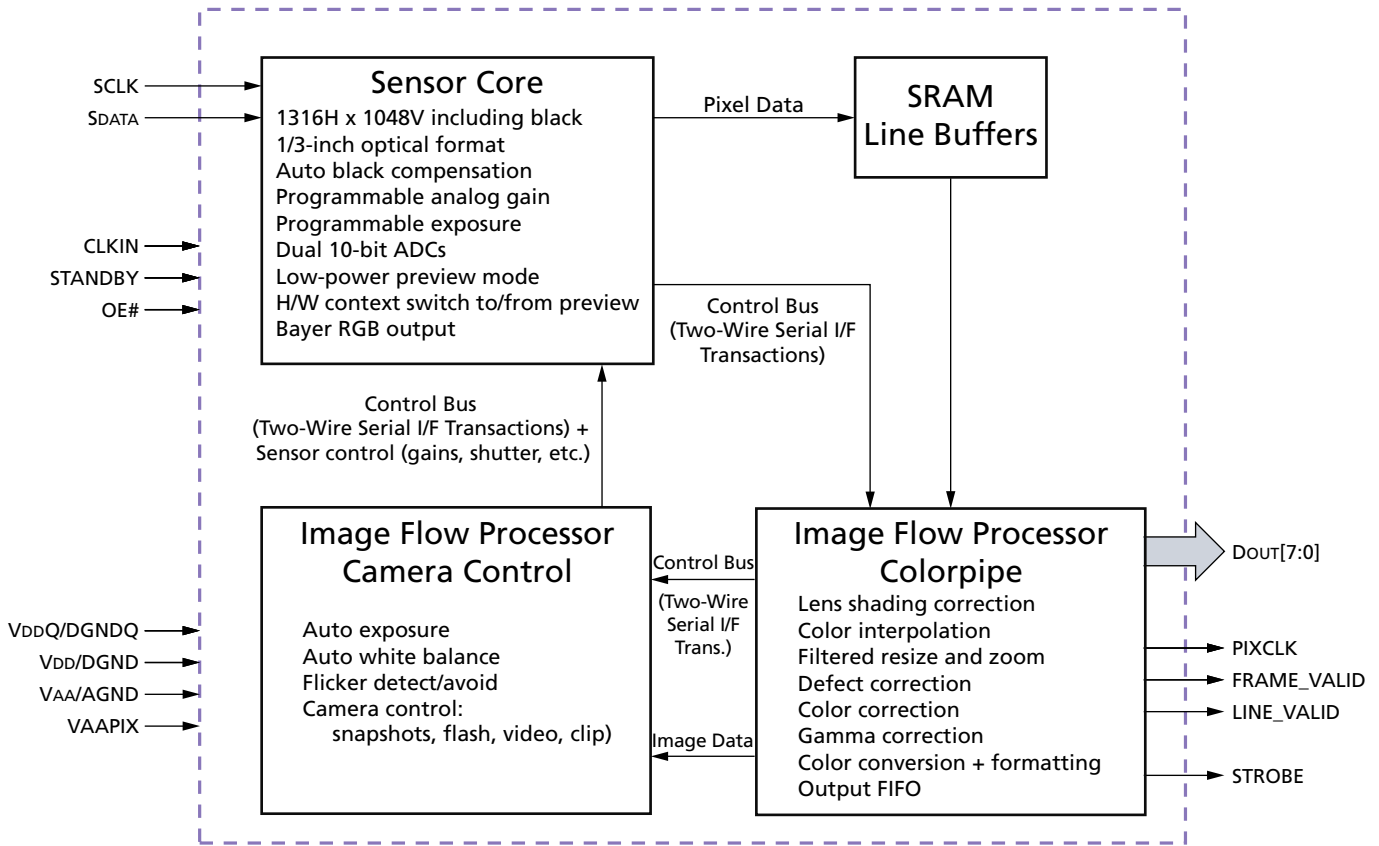
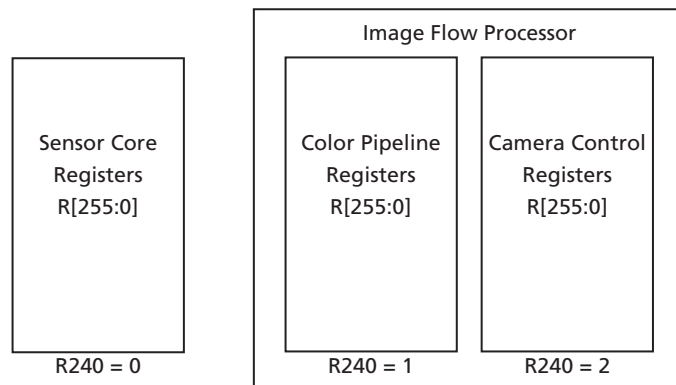

Figure 2: Internal Registers Grouping



NOTE:

Internal registers are grouped in three address spaces. Program R240 to select the desired address space.



Typical Connections

Figure 3 shows typical MT9M111 device connections. For low-noise operation, the MT9M111 requires separate power supplies for analog and digital. Incoming digital and analog ground conductors can be tied together next to the die. Both power supply rails

should be decoupled to ground using ceramic capacitors. The use of inductance filters is not recommended.

The MT9M111 also supports different digital core (VDD/DGND) and I/O power (VDDQ/DGNDQ) power domains that can be at different voltages.

Figure 3: Typical Configuration (Connection)

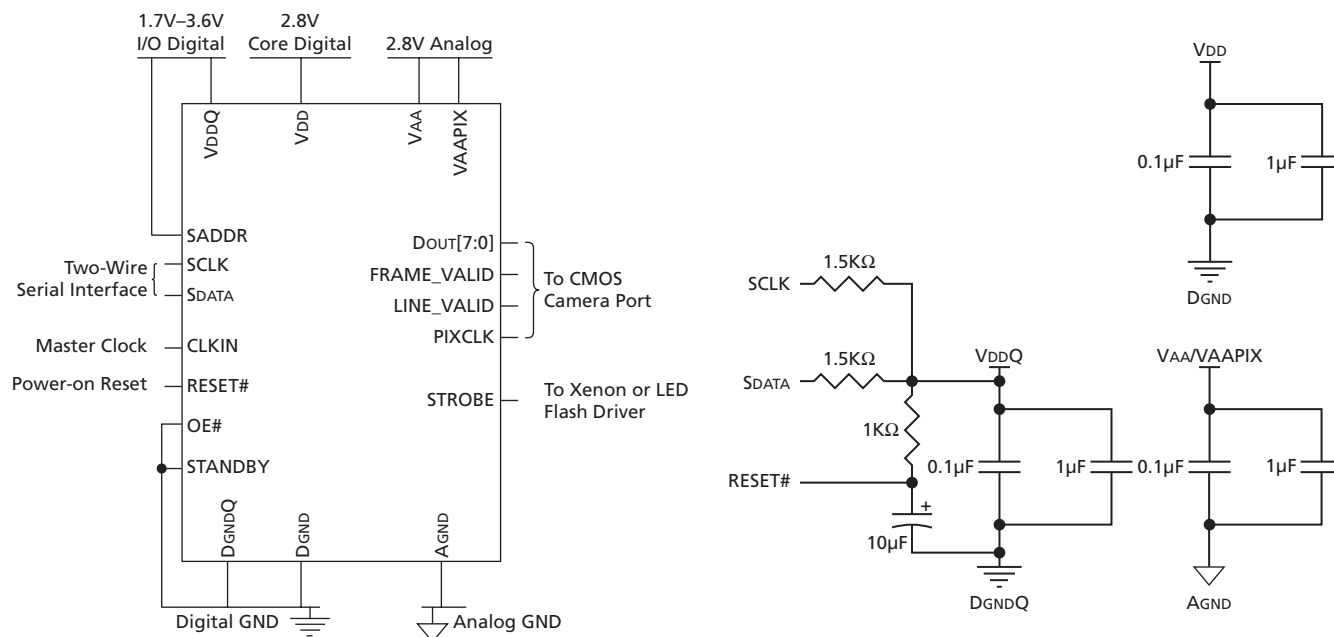

NOTE:

1. 1.5KΩ resistor value recommended, but may be greater for slower two-wire speed.
2. VDD, VAA, VAAPIX must all be at the same potential, though if connected, care must be taken to avoid excessive noise injection in the VAA/VAAPIX power domains.

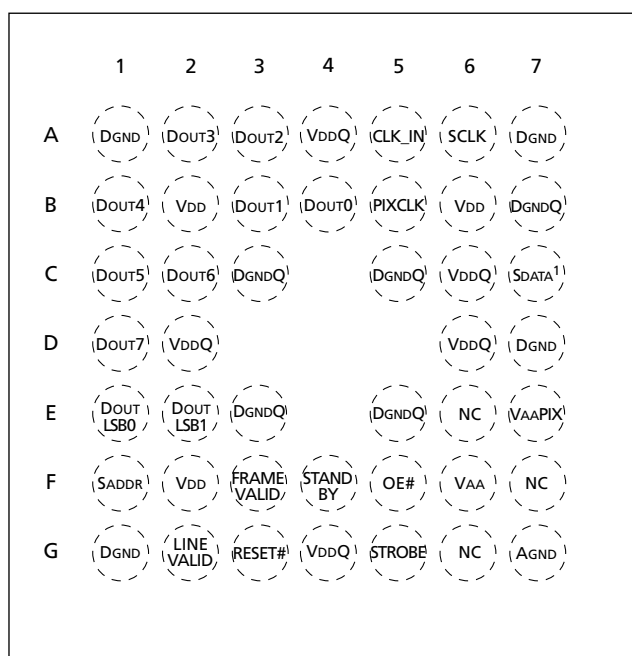
Figure 4: 44-Ball iCSP Assignment

 Top View
 (Ball Down)

NOTE:

1. Bidirectional.

Table 2: Pin Descriptions

PIN NAME	PIN TYPE	DEFAULT OPERATION	DESCRIPTION
CLKIN	Bidirectional	Input	Master Clock in Sensor.
OE#	Bidirectional	Input	Active LOW: output enable for Data[7:0].
RESET#	Bidirectional	Input	Active LOW: asynchronous reset.
SADDR	Bidirectional	Input	Two-Wire Serial Interface DeviceID selection 1:0xBA, 0:0x90.
SCLK	Bidirectional	Input	Two-Wire Serial Interface Clock.
STANDBY	Bidirectional	Input	Active HIGH: disables imager.
SDATA	Bidirectional	Input	Two-Wire Serial Interface Data I/O.
DOUT0	Bidirectional	Output	Pixel Data Output 0 (LSB).
DOUT1	Bidirectional	Output	Pixel Data Output 1.
DOUT2	Bidirectional	Output	Pixel Data Output 2.
DOUT3	Bidirectional	Output	Pixel Data Output 3.
DOUT4	Bidirectional	Output	Pixel Data Output 4.
DOUT5	Bidirectional	Output	Pixel Data Output 5.
DOUT6	Bidirectional	Output	Pixel Data Output 6.
DOUT7	Bidirectional	Output	Pixel Data Output 7 (MSB).
DOUT_LSB0	Bidirectional	Output	Sensor bypass mode output 0—typically left unconnected for normal SOC operation.

Table 2: Pin Descriptions (continued)

PIN NAME	PIN TYPE	DEFAULT OPERATION	DESCRIPTION
DOUT_LSB1	Bidirectional	Output	Sensor bypass mode output 1—typically left unconnected for normal SOC operation.
FRAME_VALID	Bidirectional	Output	Active HIGH: FRAME_VALID; indicates active frame.
LINE_VALID	Bidirectional	Output	Active HIGH: LINE_VALID, DATA_VALID; indicates active pixel.
PIXCLK	Bidirectional	Output	Pixel Clock Output.
STROBE	Bidirectional	Output	Active HIGH: strobe (Xenon) or turn on (LED) flash.
AGND		Supply	Analog Ground.
DGND		Supply	Core Digital Ground.
DGNDQ		Supply	I/O Digital Ground.
VAA		Supply	Analog Power (2.5V–3.1V).
VAAPIX		Supply	Pixel Array Analog Power Supply (2.5V–3.1V).
VDD		Supply	Core Digital Power (2.5V–3.1V).
VDDQ		Supply	I/O Digital Power (1.7V–3.6V).
NC		—	No connect.

NOTE:

All inputs and outputs are implemented with bidirectional buffers. Care must be taken that all inputs are driven and all outputs are driven if tri-stated.

Architecture Overview

The MT9M111 consists of a sensor core, the color-processing pipeline, and a measurement and control logic block (the camera controller). The following is a brief overview of the architecture.

Sensor Core

The sensor core is taken from the MT9M011 stand-alone sensor and includes a number of features specifically targeting the mobile market. Of primary interest is support for low-power preview/viewfinding with hardware-accelerated switching to full-resolution for snapshots. This switch can be achieved without adversely affecting exposure or color balance. This enables taking single-frame and Xenon flash snapshots while minimizing snapshot lag. LED snapshots are discussed below; they also benefit significantly from this feature.

Lens-Shading Correction and Black Level Conditioning

The stream of raw data from the sensor enters the pipeline and undergoes several transformations. Image stream processing starts with conditioning the black level and applying a digital gain.

The lens-shading block compensates for spatially varying signal loss caused by the lens. The block is programmable and implements separate correction functions for R,G, and B independently.

Defect Correction

Following lens correction, the data stream is analyzed for the presence of defects. A two-dimensional digital filter calculates suitable replacement values. Edge sensitivity minimizes false detections, helping to preserve image sharpness.

Interpolation, Aperture, and Color Correction

The Bayer pixel pattern data is interpolated to recover missing color components for each pixel following defect correction. Configurable aperture correction sharpens the image and to avoid amplifying noise, can be programmed to be less aggressive in low-light conditions.

The resulting interpolated RGB data passes through the current color correction matrix (CCM), gamma, and color saturation corrections.

The CCM can be manually loaded or dynamically configured by the AWB unit. The gamma correction unit is fully user-programmable, and color saturation

adjustments can be made both by the user and the auto exposure unit (for dynamic saturation reduction in high or low-lighting situations).

Resize

The IFP can resize to virtually any output resolution through digitally filtered sub-sampling. Output resolutions include, but are not limited to, VGA, QVGA, CIF, and QCIF. When the output resolution is smaller than the sensor-generated image, smooth, continuous zoom and pan become available. The user simply defines the zoom window, pan offset, and output resolution, and the resizer calculates all other parameters for the resize function.

Camera Control

The camera controller continuously accumulates image brightness and color statistics. Two units use these measurements to adjust the sensor and color-pipe settings. The auto exposure unit adjusts gain and shutter width to maintain a user-defined luma target. The image measurement region can be modified to permit, for example, backlight compensation. The user can also control the speed and sensitivity of the algorithm from highly responsive (for LED flash and view-finding) to somewhat dampened (for video). Finally, the unit can detect 50Hz or 60Hz rolling flicker bars (due to ambient illumination) and adjusts exposure appropriately to eliminate this adverse effect on image quality.

The AWB module adjusts gains and the CCM to compensate for the effects of changing scene illumination on the quality of the color rendition. The user has control over the region of the scene to be analyzed as well as the responsivity of the algorithm to illuminant changes.

Camera Interface and Test Patterns

The MT9M111 outputs processed video as a standard ITU-R BT.656 stream, an RGB stream, or as processed or unprocessed Bayer data. The ITU-R BT.656 stream contains YCbCr 4:2:2 data with optional embedded synchronization codes. This output is typically suitable for subsequent display by standard (progressive scan) video equipment, or JPEG/MPEG compression. RGB functionality provides support for LCD devices.

The MT9M111 can be configured to output 16-bit RGB (RGB565), 15-bit RGB (RGB555), and two types of 12-bit RGB (RGB444). The user can configure internal



registers to swap odd and even bytes, chrominance channels, and luminance and chrominance components to ease interfacing to application processors.

To assist in integration and system debug, a variety of test patterns are provided, from simple ramps to colorbars.

Contexts, Snapshots, and Flash

For a number of parameters, registers are provided for storing two “contexts”: Context A and Context B. These contexts enable the user to setup the camera for a number of different modes, then switch between modes with a single register write to the Global Context Control Register (GCCR). A typical example is to use Context A for viewfinder/preview settings and Context B for snapshots. Functions supporting context switching include:

- Sensor core image array readout (e.g., low-power QSXGA preview to/from full-power SXGA snapshot)
- The resizer (output resolutions for preview and snapshot)
- Camera interface (e.g., RGB565 for LCD preview and YCbCr for snapshots)

To facilitate taking snapshots and flash snapshots, the IFP includes a camera-control sequencer that automates the process of stepping through a number of preset configurable programs. In addition to basic snapshots, there are programs for both Xenon and LED assisted snapshots. A flash-triggering controller provides an appropriate timing strobe for synchronizing the onset of flash illumination with the rolling shutter.



Output Data Ordering

Table 3: Data Ordering in YCbCr Mode

MODE	BYTE			
Default	Cbi	Yi	Cri	Yi+1
Swap CrCb	Cri	Yi	Cbi	Yi+1
SwapYC	Yi	Cbi	Yi+1	Cri
Swap CrCb, SwapYC	Yi	Cri	Yi+1	Cbi

Table 4: Output Data Ordering in Processed Bayer Mode

MODE	LINE	BYTE			
Default	First	Gi	Ri+1	Gi+2	Ri+3
	Second	Bi	Gi+1	Bi+2	Gi+3
Flip Bayer Col	First	Ri	Gi+1	Ri+2	Gi+3
	Second	Gi	Bi+1	Gi+2	Bi+3
Flip Bayer Row	First	Bi	Gi+1	Bi+2	Gi+3
	Second	Gi	Ri+1	Gi+2	Ri+3
Flip Bayer Col, Flip Bayer Row	First	Gi	Bi+1	Gi+2	Bi+3
	Second	Ri	Gi+1	Ri+2	Gi+3

Table 5: Output Data Ordering in RGB Mode

MODE (SWAP DISABLED)	BYTE	D7	D6	D5	D4	D3	D2	D1	D0
RGB565	First	R7	R6	R5	R4	R3	G7	G6	G5
	Second	G4	G3	G2	B7	B6	B5	B4	B3
RGB555	First	0	R7	R6	R5	R4	R3	G7	G6
	Second	G5	G4	G3	B7	B6	B5	B4	B3
RGB444x	First	R7	R6	R5	R4	G7	G6	G5	G4
	Second	B7	B6	B5	B4	0	0	0	0
RGBx444	First	0	0	0	0	R7	R6	R5	R4
	Second	G7	G6	G5	G4	B7	B6	B5	B4

Table 6: Output Data Ordering in (8 + 2) Bypass Mode

MODE	BYTE	D7	D6	D5	D4	D3	D2	D1	D0
8 + 2 bypass	First	B9	B8	B7	B6	B5	B4	B3	B2
	Second	0	0	0	0	0	0	B1	B0

IFP Register List
Table 7: Colorpipe Registers (Address Page 1)

REGISTER #DEC (HEX)	REGISTER NAME	DATA FORMAT	DEFAULT VALUE DEC (HEX)	MODULE
5 (05)	Aperture Correction	0000 0000 0000 dddd	3 (0003)	Interp
6 (06)	Operating Mode Control	dddd dddd 0ddd dddd	28686 (700E)	Cfg
8 (08)	Output Format Control	0000 0ddd dddd dddd	128 (0080)	Cfg
16 (10)	Reserved	—	61437 (EFFD)	—
17 (11)	Reserved	—	64831 (FD3F)	—
18 (12)	Reserved	—	16367 (3FEF)	—
19 (13)	Reserved	—	N/A	—
20 (14)	Reserved	—	N/A	—
21 (15)	Reserved	—	N/A	—
27 (1B)	Reserved	—	0 (0000)	—
28 (1C)	Reserved	—	0 (0000)	—
29 (1D)	Reserved	—	N/A	—
30 (1E)	Reserved	—	512 (0200)	—
37 (25)	Color Saturation Control	0000 0000 00dd dddd	5 (0005)	rgb2yuv
52 (34)	Luma Offset	dddd dddd dddd dddd	16 (0010)	CamInt
53 (35)	Luma Clip	dddd dddd dddd dddd	61456 (F010)	CamInt
58 (3A)	Output Format Control 2—Context A	0ddd dddd dddd dddd	512 (0200)	CamInt
59 (3B)	Lens Correction Parameter 1	—	1066 (042A)	LensCorr
60 (3C)	Lens Correction Parameter 2	—	1024 (0400)	LensCorr
71 (47)	Reserved	—	24 (0018)	—
72 (48)	Test Pattern Generator Control	0000 0000 d000 0ddd	0 (0000)	FifoInt
76 (4C)	Defect Correction Context A	0000 0000 0000 0ddd	0 (0000)	DfctCorr
77 (4D)	Defect Correction Context B	0000 0000 0000 0ddd	0 (0000)	DfctCorr
78 (4E)	Reserved	—	10 (000A)	—
80 (50)	Reserved	—	N/A	—
82 (52)	Reserved	—	0 (0000)	—
83 (53)	Gamma Correction Parameter 1	—	7700 (1E14)	GmaCorr
84 (54)	Gamma Correction Parameter 2	—	17966 (462E)	GmaCorr
85 (55)	Gamma Correction Parameter 3	—	34666 (876A)	GmaCorr
86 (56)	Gamma Correction Parameter 4	—	47008 (B7A0)	GmaCorr
87 (57)	Gamma Correction Parameter 5	—	57548 (E0CC)	GmaCorr
88 (58)	Gamma Correction Parameter 6	—	0 (0000)	GmaCorr
104 (68)	Reserved	—	17 (0011)	—
128 (80)	Lens Correction Parameter 3	—	7 (0007)	LensCorr
129 (81)	Lens Correction Parameter 4	—	56588 (DD0C)	LensCorr
130 (82)	Lens Correction Parameter 5	—	62696 (F4E8)	LensCorr
131 (83)	Lens Correction Parameter 6	—	1276 (04FC)	LensCorr
132 (84)	Lens Correction Parameter 7	—	57868 (E20C)	LensCorr
133 (85)	Lens Correction Parameter 8	—	63212 (F6EC)	LensCorr
134 (86)	Lens Correction Parameter 9	—	764 (02FC)	LensCorr
135 (87)	Lens Correction Parameter 10	—	56588 (DD0C)	LensCorr
136 (88)	Lens Correction Parameter 11	—	62696 (F4E8)	LensCorr
137 (89)	Lens Correction Parameter 12	—	250 (00FA)	LensCorr

Table 7: Colorpipe Registers (Address Page 1) (continued)

REGISTER #DEC (HEX)	REGISTER NAME	DATA FORMAT	DEFAULT VALUE DEC (HEX)	MODULE
138 (8A)	Lens Correction Parameter 13	—	34866 (8832)	LensCorr
139 (8B)	Lens Correction Parameter 14	—	56754 (DDB2)	LensCorr
140 (8C)	Lens Correction Parameter 15	—	63466 (F7EA)	LensCorr
141 (8D)	Lens Correction Parameter 16	—	2 (0002)	LensCorr
142 (8E)	Lens Correction Parameter 17	—	47646 (BA1E)	LensCorr
143 (8F)	Lens Correction Parameter 18	—	60627 (ECD3)	LensCorr
144 (90)	Lens Correction Parameter 19	—	63473 (F7F1)	LensCorr
145 (91)	Lens Correction Parameter 20	—	255 (00FF)	LensCorr
146 (92)	Lens Correction Parameter 21	—	48926 (BF1E)	LensCorr
147 (93)	Lens Correction Parameter 22	—	61142 (EED6)	LensCorr
148 (94)	Lens Correction Parameter 23	—	63474 (F7F2)	LensCorr
149 (95)	Lens Correction Parameter 24	—	3 (0003)	LensCorr
153 (99)	Line Counter	???? ???? ???? ????	N/A	CamInt
154 (9A)	Frame Counter	???? ???? ???? ????	N/A	CamInt
155 (9B)	Output Format Control 2—Context B	0ddd dddd dddd dddd	512 (0200)	CamInt
157 (9D)	Reserved	—	9390 (24AE)	—
158 (9E)	Reserved	—	N/A	—
159 (9F)	Reducer Horizontal Pan—Context B	0d00 0ddd dddd dddd	0 (0000)	Interp
160 (A0)	Reducer Horizontal Zoom—Context B	0000 0ddd dddd dddd	1280 (0500)	Interp
161 (A1)	Reducer Horizontal Size—Context B	0000 0ddd dddd dddd	1280 (0500)	Interp
162 (A2)	Reducer Vertical Pan—Context B	0d00 0ddd dddd dddd	0 (0000)	Interp
163 (A3)	Reducer Vertical Zoom—Context B	0000 0ddd dddd dddd	1024 (0400)	Interp
164 (A4)	Reducer Vertical Size—Context B	0000 0ddd dddd dddd	1024 (0400)	Interp
165 (A5)	Reducer Horizontal Pan—Context A	0d00 0ddd dddd dddd	0 (0000)	Interp
166 (A6)	Reducer Horizontal Zoom—Context A	0000 0ddd dddd dddd	1280 (0500)	Interp
167 (A7)	Reducer Horizontal Size—Context A	0000 0ddd dddd dddd	640 (0280)	Interp
168 (A8)	Reducer Vertical Pan—Context A	0d00 0ddd dddd dddd	0 (0000)	Interp
169 (A9)	Reducer Vertical Zoom—Context A	0000 0ddd dddd dddd	1024 (0400)	Interp
170 (AA)	Reducer Vertical Size—Context A	0000 0ddd dddd dddd	512 (0200)	Interp
171 (AB)	Reducer Current Zoom Horizontal	???? 0??? ???? ????	N/A	Interp
172 (AC)	Reducer Current Zoom Vertical	???? 0??? ???? ????	N/A	Interp
174 (AE)	Reducer Zoom Step Size	dddd dddd dddd dddd	1284 (0504)	Interp
175 (AF)	Reducer Zoom Control	0000 00dd 0ddd dddd	16 (0010)	Interp
179 (B3)	Global Clock Control	0000 0000 0000 00dd	2 (0002)	ClockRst
180 (B4)	Reserved	—	32 (0020)	—
181 (B5)	Uniform Clocking Control Parameter	—	257 (0101)	—
182 (B6)	Lens Correction Parameter 25	—	4363 (110B)	LensCorr
183 (B7)	Lens Correction Parameter 26	—	15399 (3C27)	LensCorr
184 (B8)	Lens Correction Parameter 27	—	4362 (110A)	LensCorr
185 (B9)	Lens Correction Parameter 28	—	12834 (3222)	LensCorr
186 (BA)	Lens Correction Parameter 29	—	5643 (160B)	LensCorr
187 (BB)	Lens Correction Parameter 30	—	12836 (3224)	LensCorr
188 (BC)	Lens Correction Parameter 31	—	9228 (240C)	LensCorr
189 (BD)	Lens Correction Parameter 32	—	24124 (5E3C)	LensCorr
190 (BE)	Lens Correction Parameter 33	—	127 (007F)	LensCorr

Table 7: Colorpipe Registers (Address Page 1) (continued)

REGISTER #DEC (HEX)	REGISTER NAME	DATA FORMAT	DEFAULT VALUE DEC (HEX)	MODULE
191 (BF)	Lens Correction Parameter 34	—	8200 (2008)	LensCorr
192 (C0)	Lens Correction Parameter 35	—	20023 (4E37)	LensCorr
193 (C1)	Lens Correction Parameter 36	—	100 (0064)	LensCorr
194 (C2)	Lens Correction Parameter 37	—	8463 (210F)	LensCorr
195 (C3)	Lens Correction Parameter 38	—	19250 (4B32)	LensCorr
196 (C4)	Lens Correction Parameter 39	—	100 (0064)	LensCorr
200 (C8)	Global Context Control	dddd dddd dddd dddd	0 (0000)	CntxCtl
201 (C9)	Reserved	—	N/A	—
202 (CA)	Reserved	—	N/A	—
203 (CB)	Reserved	—	N/A	—
204 (CC)	Reserved	—	N/A	—
205 (CD)	Reserved	—	N/A	—
206 (CE)	Reserved	—	N/A	—
207 (C)	Reserved	—	N/A	—
208 (D0)	Reserved	—	N/A	—
220 (DC)	Gamma Correction Parameter 7	—	7700 (1E14)	GmaCorr
221 (DD)	Gamma Correction Parameter 8	—	17966 (462E)	GmaCorr
222 (DE)	Gamma Correction Parameter 9	—	34666 (876A)	GmaCorr
223 (DF)	Gamma Correction Parameter 10	—	47008 (B7A0)	GmaCorr
224 (E0)	Gamma Correction Parameter 11	—	57548 (E0CC)	GmaCorr
225 (E1)	Gamma Correction Parameter 12	—	0 (0000)	GmaCorr
226 (E2)	Effects Mode	dddd dddd 0000 0ddd	28672 (7000)	GmaCorr
227 (E3)	Effects Sepia	dddd dddd dddd dddd	45091 (B023)	GmaCorr
240 (F0)	Page Map	0000 0000 0000 0ddd	0 (0000)	Cfg
241 (F1)	Byte-wise Address	—	Reserved	—

Table 8: Camera Control Registers (Address Page 2)

REGISTER #DEC (HEX)	REGISTER NAME	DATA FORMAT	DEFAULT VALUE DEC (HEX)	MODULE
2 (02)	Color Correction Parameter 1	—	110 (006E)	ColorCorr
3 (03)	Color Correction Parameter 2	—	10531 (2923)	ColorCorr
4 (04)	Color Correction Parameter 3	—	1316 (0524)	ColorCorr
9 (09)	Color Correction Parameter 4	—	146 (0092)	ColorCorr
10 (0A)	Color Correction Parameter 5	—	22 (0016)	ColorCorr
11 (0B)	Color Correction Parameter 6	—	8 (0008)	ColorCorr
12 (0C)	Color Correction Parameter 7	—	171 (00AB)	ColorCorr
13 (0D)	Color Correction Parameter 8	—	147 (0093)	ColorCorr
14 (0E)	Color Correction Parameter 9	—	88 (0058)	ColorCorr
15 (0F)	Color Correction Parameter 10	—	77 (004D)	ColorCorr
16 (10)	Color Correction Parameter 11	—	169 (00A9)	ColorCorr
17 (11)	Color Correction Parameter 12	—	160 (00A0)	ColorCorr
18 (12)	Color Correction Parameter 13	—	N/A	ColorCorr
19 (13)	Color Correction Parameter 14	—	N/A	ColorCorr

Table 8: Camera Control Registers (Address Page 2) (continued)

REGISTER #DEC (HEX)	REGISTER NAME	DATA FORMAT	DEFAULT VALUE DEC (HEX)	MODULE
20 (14)	Color Correction Parameter 15	—	N/A	ColorCorr
21 (15)	Color Correction Parameter 16	—	373 (0175)	ColorCorr
22 (16)	Color Correction Parameter 17	—	22 (0016)	ColorCorr
23 (17)	Color Correction Parameter 18	—	67 (0043)	ColorCorr
24 (18)	Color Correction Parameter 19	—	12 (000C)	ColorCorr
25 (19)	Color Correction Parameter 20	—	0 (0000)	ColorCorr
26 (1A)	Color Correction Parameter 21	—	21 (0015)	ColorCorr
27 (1B)	Color Correction Parameter 22	—	31 (001F)	ColorCorr
28 (1C)	Color Correction Parameter 23	—	22 (0016)	ColorCorr
29 (1D)	Color Correction Parameter 24	—	152 (0098)	ColorCorr
30 (1E)	Color Correction Parameter 25	—	76 (004C)	ColorCorr
31 (1F)	AWB Parameter 1	—	160 (00A0)	AWB
32 (20)	AWB Parameter 2	—	51220 (C814)	AWB
33 (21)	AWB Parameter 3	—	32896 (8080)	AWB
34 (22)	AWB Parameter 4	—	55648 (D960)	AWB
35 (23)	AWB Parameter 5	—	55648 (D960)	AWB
36 (24)	AWB Parameter 6	—	32512 (7F00)	AWB
38 (26)	Auto Exposure Window Horizontal Boundaries	dddd dddd dddd dddd	32768 (8000)	AutoExp
39 (27)	Auto Exposure Window Vertical Boundaries	dddd dddd dddd dddd	32776 (8008)	AutoExp
40 (28)	AWB Parameter 7	—	61188 (EF04)	AWB
41 (29)	AWB Parameter 8	—	36211 (8D73)	AWB
42 (2A)	AWB Parameter 9	—	208 (00D0)	AWB
43 (2B)	Auto Exposure Center Horizontal Window Boundaries	dddd dddd dddd dddd	24608 (6020)	AutoExp
44 (2C)	Auto Exposure Center Vertical Window Boundaries	dddd dddd dddd dddd	24608 (6020)	AutoExp
45 (2D)	AWB Window Boundaries	dddd dddd dddd dddd	61600 (F0A0)	AWB
46 (2E)	Auto Exposure Target and Precision Control	dddd dddd dddd dddd	3146 (0C4A)	AutoExp
47 (2F)	Auto Exposure Speed and Sensitivity Control— Context A	dddd dddd dddd dddd	57120 (DF20)	AutoExp
48 (30)	AWB Parameter 10	—	N/A	AWB
49 (31)	AWB Parameter 11	—	N/A	AWB
50 (32)	AWB Parameter 12	—	N/A	AWB
51 (33)	Auto Exposure Parameter 1	—	5230 (146E)	AutoExp
54 (36)	Auto Exposure Parameter 2	—	30736 (7810)	AutoExp
55 (37)	Auto Exposure Parameter 3	—	768 (0300)	AutoExp
56 (38)	Auto Exposure Parameter 4	—	1088 (0440)	AutoExp
57 (39)	Auto Exposure Parameter 5	—	1676 (068C)	AutoExp
58 (3A)	Auto Exposure Parameter 6	—	1676 (068C)	AutoExp
59 (3B)	Auto Exposure Parameter 7	—	1676 (068C)	AutoExp
60 (3C)	Auto Exposure Parameter 8	—	1676 (068C)	AutoExp
61 (3D)	Auto Exposure Parameter 9	—	6105 (17D9)	AutoExp
62 (3E)	AWB Parameter 13	—	7423 (1CFF)	AWB
63 (3F)	Auto Exposure Parameter 10	—	N/A	AutoExp
70 (46)	Auto Exposure Parameter 11	—	55552 (D900)	AutoExp
75 (4B)	Reserved	—	0 (0000)	—
76 (4C)	Auto Exposure Parameter 12	—	N/A	AutoExp

Table 8: Camera Control Registers (Address Page 2) (continued)

REGISTER #DEC (HEX)	REGISTER NAME	DATA FORMAT	DEFAULT VALUE DEC (HEX)	MODULE
77 (4D)	Auto Exposure Parameter 13	—	N/A	AutoExp
79 (4F)	Reserved	—	N/A	—
87 (57)	Auto Exposure Parameter 14	—	537 (0219)	AutoExp
88 (58)	Auto Exposure Parameter 15	—	644 (0284)	AutoExp
89 (59)	Auto Exposure Parameter 16	—	537 (0219)	AutoExp
90 (5A)	Auto Exposure Parameter 17	—	644 (0284)	AutoExp
91 (5B)	Flicker Control 0	?000 0000 0000 0ddd	2 (0002)	FD
92 (5C)	Reserved	—	4620 (120C)	—
93 (5D)	Reserved	—	5394 (1512)	—
94 (5E)	Color Correction Parameter 26	—	26684 (683C)	ColorCorr
95 (5F)	Color Correction Parameter 27	—	12296 (3008)	ColorCorr
96 (60)	Color Correction Parameter 28	—	2 (0002)	ColorCorr
97 (61)	Reserved	—	32896 (8080)	—
98 (62)	Auto Exposure Digital Gains Monitor	???? ???? ???? ???? ?	N/A	AutoExp
99 (63)	Reserved	—	N/A	—
100 (64)	Reserved	—	23036 (59FC)	—
101 (65)	Auto Exposure Parameter 18	—	0 (0000)	AutoExp
103 (67)	Auto Exposure Digital Gain Limits	dddd dddd dddd dddd	16400 (4010)	AutoExp
104 (68)	Reserved	—	17 (0011)	—
106 (6A)	Reserved	—	N/A	—
107 (6B)	Reserved	—	N/A	—
108 (6C)	Reserved	—	N/A	—
109 (6D)	Reserved	—	N/A	—
110 (6E)	Reserved	—	N/A	—
111 (6F)	Reserved	—	N/A	—
112 (70)	Reserved	—	N/A	—
113 (71)	Reserved	—	N/A	—
114 (72)	Reserved	—	N/A	—
115 (73)	Reserved	—	N/A	—
116 (74)	Reserved	—	N/A	—
117 (75)	Reserved	—	N/A	—
118 (76)	Reserved	—	N/A	—
119 (77)	Reserved	—	N/A	—
120 (78)	Reserved	—	N/A	—
121 (79)	Reserved	—	N/A	—
122 (7A)	Reserved	—	N/A	—
123 (7B)	Reserved	—	N/A	—
124 (7C)	Reserved	—	N/A	—
125 (7D)	Reserved	—	N/A	—
130 (82)	Auto Exposure Parameter 19	—	1020 (03FC)	AutoExp
131 (83)	Auto Exposure Parameter 20	—	769 (0301)	AutoExp
132 (84)	Auto Exposure Parameter 21	—	193 (00C1)	AutoExp
133 (85)	Auto Exposure Parameter 22	—	929 (03A1)	AutoExp
134 (86)	Auto Exposure Parameter 23	—	980 (03D4)	AutoExp
135 (87)	Auto Exposure Parameter 24	—	983 (03D7)	AutoExp

Table 8: Camera Control Registers (Address Page 2) (continued)

REGISTER #DEC (HEX)	REGISTER NAME	DATA FORMAT	DEFAULT VALUE DEC (HEX)	MODULE
136 (88)	Auto Exposure Parameter 25	—	921 (0399)	AutoExp
137 (89)	Auto Exposure Parameter 26	—	1016 (03F8)	AutoExp
138 (8A)	Auto Exposure Parameter 27	—	28 (001C)	AutoExp
139 (8B)	Auto Exposure Parameter 28	—	957 (03BD)	AutoExp
140 (8C)	Auto Exposure Parameter 29	—	987 (03DB)	AutoExp
141 (8D)	Auto Exposure Parameter 30	—	957 (03BD)	AutoExp
142 (8E)	Auto Exposure Parameter 31	—	1020 (03FC)	AutoExp
143 (8F)	Auto Exposure Parameter 32	—	990 (03DE)	AutoExp
144 (90)	Auto Exposure Parameter 33	—	990 (03DE)	AutoExp
145 (91)	Auto Exposure Parameter 34	—	990 (03DE)	AutoExp
146 (92)	Auto Exposure Parameter 35	—	990 (03DE)	AutoExp
147 (93)	Auto Exposure Parameter 36	—	31 (001F)	AutoExp
148 (94)	Auto Exposure Parameter 37	—	65 (0041)	AutoExp
149 (95)	Auto Exposure Parameter 38	—	867 (0363)	AutoExp
150 (96)	Reserved	—	0 (0000)	—
151 (97)	Reserved	—	N/A	—
152 (98)	Reserved	—	255 (00FF)	—
153 (99)	Reserved	—	1 (0001)	—
156 (9C)	Auto Exposure Speed and Sensitivity Control— Context B	dddd dddd dddd dddd	57120 (DF20)	AutoExp
180 (B4)	Reserved	—	32 (0020)	—
181 (B5)	Reserved	—	N/A	—
198 (C6)	Reserved	—	0 (0000)	—
199 (C7)	Reserved	—	N/A	—
200 (C8)	Global Context Control	dddd dddd dddd dddd	0 (0000)	CntxCtl
201 (C9)	Camera Control Sequencer Parameter 1	—	N/A	CamCtl
202 (CA)	Camera Control Sequencer Parameter 2	—	N/A	CamCtl
203 (CB)	Camera Control Sequencer Parameter 3	—	0 (0000)	CamCtl
204 (CC)	Camera Control Sequencer Parameter 4	—	0 (0000)	CamCtl
205 (CD)	Camera Control Sequencer Parameter 5	—	8608 (21A0)	CamCtl
206 (CE)	Camera Control Sequencer Parameter 6	—	7835 (1E9B)	CamCtl
207 (CF)	Camera Control Sequencer Parameter 7	—	19018 (4A4A)	CamCtl
208 (D0)	Camera Control Sequencer Parameter 8	—	5773 (168D)	CamCtl
209 (D1)	Camera Control Sequencer Parameter 9	—	77 (004D)	CamCtl
210 (D2)	Camera Control Sequencer Parameter 10	—	0 (0000)	CamCtl
211 (D3)	Context Control Parameter 1	—	0 (0000)	CntxCtl
212 (D4)	Camera Control Sequencer Parameter 11	—	520 (0208)	CamCtl
213 (D5)	Camera Control Sequencer Parameter 12	—	0 (0000)	CamCtl
239 (EF)	AWB Parameter 14	—	8 (0008)	AWB
240 (F0)	Page Map	0000 0000 0000 0ddd	0 (0000)	Cfg
241 (F1)	Byte-wise Address	—	Reserved	—
242 (F2)	AWB Parameter 15	—	0 (0000)	AWB
243 (F3)	Reserved	—	0 (0000)	—
244 (F4)	Color Correction Parameter 29	—	110 (006E)	ColorCorr
245 (F5)	Color Correction Parameter 30	—	135 (0087)	ColorCorr

Table 8: Camera Control Registers (Address Page 2) (continued)

REGISTER #DEC (HEX)	REGISTER NAME	DATA FORMAT	DEFAULT VALUE DEC (HEX)	MODULE
246 (F6)	Color Correction Parameter 31	—	54 (0036)	ColorCorr
247 (F7)	Color Correction Parameter 32	—	13 (000D)	ColorCorr
248 (F8)	Color Correction Parameter 33	—	171 (00AB)	ColorCorr
249 (F9)	Color Correction Parameter 34	—	136 (0088)	ColorCorr
250 (FA)	Color Correction Parameter 35	—	72 (0048)	ColorCorr
251 (FB)	Color Correction Parameter 36	—	87 (0057)	ColorCorr
252 (FC)	Color Correction Parameter 37	—	94 (005E)	ColorCorr
253 (FD)	Color Correction Parameter 38	—	122 (007A)	ColorCorr
254 (FE)	Color Correction Parameter 39	—	20543 (503F)	ColorCorr
255 (FF)	Color Correction Parameter 40	—	43136 (A880)	ColorCorr

NOTE:

Data Format Key:

0 = "Don't Care" bit. The exceptions: R0:0 and R255:0, which are hardwired R/O binary values.

d = R/W bit

? = R/O bit.



IFP Register Description

Configuration

The vast majority of IFP registers associate naturally to one of the IFP modules. These modules are identified in Table 8 on page 17. Detailed register descriptions follow in Table 9. A few registers create effects across a number of module functions. These include

R240 page map register (R/W); R6:1 0x106 operating mode control register (R/W); R8:1 0x108 output format control register (R/W); the R62:2 0x23E gain types and CCM threshold register—the gain threshold for CCM adjustment (R/W).

Table 9: Colorpipe Register Description

REGISTER# (HEX)	DESCRIPTION
R5:1—0X105 - APERTURE CORRECTION	
Default	0x0003
Description	Aperture correction scale factor, used for sharpening.
Bit 3	Enables automatic sharpness reduction control (see R51:2 0x233).
Bits 2:0	Sharpening factor: "000"—No sharpening. "001"—25% sharpening. "010"—50% sharpening. "011"—75% sharpening. "100"—100% sharpening. "101"—125% sharpening. "110"—150% sharpening. "111"—200% sharpening.
R6:1—0X106 - OPERATING MODE CONTROL (R/W)	
Default	0x700E
Description	This register specifies the operating mode of the IFP.
Bit 15	Enables manual white balance. User can set the base matrix and color channel gains. This bit must be asserted and de-asserted with a frame in between to force new color correction settings to take effect.
Bit 14	Enables auto exposure.
Bit 13	Enables on-the-fly defect correction.
Bit 12	Clips aperture corrections. Small aperture corrections (< 8) are attenuated to reduce noise amplification.
Bit 11	Load color correction matrix 1: In manual white balance mode, triggers the loading of a new base matrix in color correction and the loading of new base sensor gain ratios. 0: Enables the matrix to be changed "offline."
Bit 10	Enables lens-shading correction. 1: Enables lens-shading correction.
Bit 9	Reserved.
Bit 8	Reserved.
Bit 7	Enables flicker detection. 1: Enables automatic flicker detection.
Bit 6	Reserved for future expansion.
Bit 5	Reserved.
Bit 4	Bypasses color correction matrix. 1: Outputs "raw" color bypassing color correction. 0: Normal color processing.

Table 9: Colorpipe Register Description (continued)

Bits 3:2	Auto exposure back light compensation control. "00"—Auto exposure sampling window is specified by R38:2 and R39:2 ("large window"). "01"—Auto exposure sampling window is specified by R43:2 and R44:2 ("small window"). "1X"—Auto exposure sampling window is specified by the weighted sum of the large window and the small window, with the small window weighted four times more heavily.
Bit 1	Enables AWB. 1: Enables auto white balance. 0: Freezes white balance at current values.
Bit 0	Reserved for future expansion.
R8:1—0X108 - OUTPUT FORMAT CONTROL (R/W)	
Default	0x0080
Description	This register specifies the output timing and format in conjunction with R58:1 or R155:1 (depending on the context).
Bits 15:10	Reserved for future expansion.
Bit 9	Flip Bayer columns in processed Bayer output mode. 0: Column order is green, red and blue, green. 1: Column order is red, green and green, blue.
Bit 8	Flip Bayer row in processed Bayer output mode. 0: First row contains green and red; the second row contains blue and green. 1: First row contains blue and green; the second row contains green and red.
Bit 7	Controls the values used for the protection bits in Rec. ITU-R BT.656 codes. 0: Use zeros for the protection bits. 1: Use the correct values.
Bit 5	Multiplexes Y (in YCbCr mode) or green (in RGB mode) channel on all channels (monochrome). 1: Forces Y/G onto all channels.
Bit 4	Disables Cab color output channel (Cb = 128) in YCbCr mode and disables the blue color output channel (B = 0) in RGB mode. 1: Forces Cab to 128 or B to 0.
Bit 3	Disables Y color output channel (Y = 128) in YCbCr and disables the green color output channel (G = 0) in RGB mode. 1: Forces Y to 128 or G to 0.
Bit 2	Disables Cr color output channel (Cr = 128) in YCbCr mode and disables the red color output channel (R = 0) in RGB mode. 1: Forces Cr to 128 or R to 0.
Bit 1	Toggles the assumptions about Bayer vertical CFA shift. 0: Row containing red comes first. 1: Row containing blue comes first.
Bit 0	Toggles the assumptions about Bayer horizontal CFA shift. 0: Green comes first. 1: Red or blue comes first.

Table 9: Colorpipe Register Description (continued)

R37:1—0X125 - COLOR SATURATION CONTROL (R/W)	
Default	0x0005
Description	This register specifies the color saturation control settings.
Bit 5:3	Specify overall attenuation of the color saturation. "000"—Full color saturation "001"—75% of full saturation "010"—50% of full saturation "011"—37.5% of full saturation "100"—25% of full saturation "101"—150% of full saturation "110"—black and white
Bit 2:0	Specify color saturation attenuation at high luminance (linearly increasing attenuation from no attenuation to monochrome at luminance of 224). "000"—No attenuation. "001"—Attenuation starts at luminance of 216. "010"—Attenuation starts at luminance of 208. "011"—Attenuation starts at luminance of 192. "100"—Attenuation starts at luminance of 160. "101"—Attenuation starts at luminance of 96.
R52:1—0X134 - LUMA OFFSET (R/W)	
Default	0x0010
Description	Offset added to the luminance prior to output.
Bits 15:8	Y Offset in YCbCr mode.
Bits 7:0	Offset in RGB mode.
R53:1—0X135 - LUMA CLIP (R/W)	
Default	0xF010
Description	Clipping limits for output luminance.
Bits 15:8	Highest value of output luminance.
Bits 7:0	Lowest value of output luminance.
R58:1—0X13A - OUTPUT FORMAT CONTROL 2—CONTEXT A (R/W)	
Default	0x0200
Description	Output format control 2A.
Bit 14	Output processed Bayer data.
Bit 13	Reserved
Bit 12	Reserved
Bit 11	Enables embedding Rec. ITU-R BT.656 synchronization codes in the output data. See R155:1
Bit 10	Entire image processing is bypassed and raw bayer is output directly. In YCbCr or RGB mode: 0: Normal operation, sensor core data flows through IFP. 1: Bypass IFP and output Imager data directly (full 10 bits). The image data still passes through the camera interface FIFO and the 10 bits are formatted to two output bytes through the camera interface; i.e., 8 + 2. Data rate is effectively the same as default 16-bit /per pixel modes. Auto exposure/AWB, etc. still function and control the sensor, though they are assuming some gain/correction through the colorpipe. See R155:1
Bit 9	Inverts output pixel clock. By default, this bit is asserted and data is launched off the falling edge of PIXCLK for capture by the receiver on the rising edge. See R155:1
Bit 8	Enables RGB output. 0: Output YCbCr data. 1: Output RGB format data as defined by R58:1[7:6].

Table 9: Colorpipe Register Description (continued)

Bits 7:6	RGB output format: "00"—16-bit RGB565. "01"—15-bit RGB555. "10"—12-bit RGB444x. "11"—12-bit RGBx444.
Bits 5:4	Test Ramp output: "00"—Off. "01"—By column. "10"—By row. "11"—By frame.
Bit 3	Outputs RGB or YCbCr values are shifted 3 bits up. Use with R58:1[5:4] to test LCDs with low color depth.
Bit 2	Averages two nearby chrominance bytes. See R155:1
Bit 1	In YCbCr mode swap C and Y bytes. In RGB mode, swap odd and even bytes. See R155:1
Bit 0	In YCbCr mode, swaps Cb and Cr channels. In RGB mode, swaps R and B channels. See R155:1
R72:1—0X148 - TEST PATTERN GENERATOR CONTROL (R/W)	
Default	0x0000
Description	This register enables test pattern generation at the input of the image processor. Values greater than "0" turn on the test pattern generator. The brightness of the flat color areas depends on the value programmed (from 6–1) in this register. The value 7 produces the color bar pattern. Value 0 selects the sensor image.
Bit 7	1: Forces WB digital gains to 1.0. 0: Normal operation.
Bits 2:0	Test pattern selection.
R76:1—0X14C - DEFECT CORRECTION—CONTEXT A (R/W)	
Default	0x0000
Description	Context A register with defect correction, mode enables, and calibration bits.
Bit 2	Reserved
Bit 1	Reserved
Bit 0	Enables 2D defect correction.
R77:1—0X14D - DEFECT CORRECTION—CONTEXT B (R/W)	
Default	0x0000
Description	Context B register with defect correction, mode enables, and calibration bits.
Bit 2	Reserved
Bit 1	Reserved
Bit 0	Enables 2D defect correction.
R153:1—0X199 - LINE COUNTER (R/O)	
Default	N/A
Description	Use line counter to determine the number of the line currently being output.
Bits 12:0	Line count.
R154:1—0X19A - FRAME COUNTER (R/O)	
Default	N/A
Description	Use frame counter to determine the index of the frame currently being output.
Bits 15:0	Frame count.
R155:1—0X19B - OUTPUT FORMAT CONTROL 2—CONTEXT B (R/W)	
Default	0x0200
Description	Output format control 2B.
Bit 14	Output processed Bayer data.

Table 9: Colorpipe Register Description (continued)

Bit 13	Reserved.
Bit 12	Reserved
Bit 11	Enables embedding Rec. ITU-R BT.656 synchronization codes to the output data. See R58:1
Bit 10	Entire image processing is bypassed and raw bayer is output directly. In YCbCr or RGB mode: 0: Normal operation, sensor core data flows through IFP. 1: Bypass IFP and output Imager data directly (full 10 bits). The image data still passes through the camera interface FIFO and the 10 bits are formatted to two output bytes through the camera interface; i.e., 8 + 2. Data rate is effectively the same as default 16-bit /per pixel modes. Auto exposure/AWB, etc. still function and control the sensor, though they are assuming some gain/correction through the colorpipe. See R58:1
Bit 9	Inverts output pixel clock. By default, this bit is asserted and data is launched off the falling edge of PIXCLK for capture by the receiver on the rising edge. See R58:1
Bit 8	Enables RGB output. 0: Output YCbCr data. 1: Output RGB format data as defined by R155:1[7:6]. See R58:1
Bits 7:6	RGB output format: "00"—16-bit RGB565. "01"—15-bit RGB555. "10"—12-bit RGB444x. "11"—12-bit RGBx444.
Bits 5:4	Test Ramp output: "00"—Off. "01"—By column. "10"—By row. "11"—By frame.
Bit 3	Output RGB or YCbCr values are shifted 3 bits up. Use with R58:1[5:4] to test LCDs with low color depth.
Bit 2	Averages two nearby chrominance bytes. See R58:1
Bit 1	In YCbCr mode swap C and Y bytes. In RGB mode, swap odd and even bytes. See R58:1
Bit 0	In YCbCr mode, swaps Cb and Cr channels. In RGB mode, swaps R and B channels. See R58:1
R159:1—0X19F - REDUCER HORIZONTAL PAN—CONTEXT B (R/W)	
Default	0x0000
Description	Controls reducer horizontal pan in Context B
Bit 14	0: MT9V111-compatible origin at X = 0. 1: Centered origin at 640 for more convenient zoom and resize.
Bits 10:0	X Pan: Unsigned offset from x = 0 (Bit 14 = 0), or two's complement from X = 640 (Bit 14 = 1).
R160:1—0X1A0 - REDUCER HORIZONTAL ZOOM—CONTEXT B (R/W)	
Default	0x0500
Description	Controls reducer horizontal width of zoom window for field of view in Context B.
Bits 10:0	X Zoom B. Must be \geq X Size B
R161:1—0X1A1 - REDUCER HORIZONTAL OUTPUT SIZE—CONTEXT B (R/W)	
Default	0x0500
Description	Controls reducer horizontal output size in Context B.
Bits 10:0	X Size B. Must be \leq X Zoom B.
R162:1—0X1A2 - REDUCER VERTICAL PAN—CONTEXT B (R/W)	
Default	0x0000
Description	Controls reducer vertical pan in Context B.
Bit 14	0: MT9V111-compatible origin at Y = 0. 1: Centered origin at Y = 512 for more convenient zoom and resize.

Table 9: Colorpipe Register Description (continued)

Bits 10:0	Y Pan: unsigned offset from Y = 0 (Bit 14 = 0), or two's complement from Y = 512 (Bit 14 = 1).
R163:1—0X1A3 - REDUCER VERTICAL ZOOM—CONTEXT B (R/W)	
Default	0x0400
Description	Controls reducer vertical height of zoom window for field of view in Context B.
Bits 10:0	Y Zoom B. Must be \geq Y Size B.
R164:1—0X1A4 - REDUCER VERTICAL OUTPUT SIZE—CONTEXT B (R/W)	
Default	0x0400
Description	Controls reducer vertical output size in Context B.
Bits 10:0	Y Size B. Must be \leq Y Zoom B.
R165:1—0X1A5 - REDUCER HORIZONTAL PAN—CONTEXT A (R/W)	
Default	0x0000
Description	Controls reducer horizontal pan in Context A.
Bit 14	0: MT9V111-compatible offset from X = 0. 1: Centered origin at 640 for more convenient zoom and resize.
Bits 10:0	X Pan: Unsigned offset from X = 0 (Bit 14 = 0), or two's complement from X = 640 (Bit 14 = 1).
R166:1—0X1A6 - REDUCER HORIZONTAL ZOOM—CONTEXT A (R/W)	
Default	0x0500
Description	Controls reducer horizontal width of zoom window for field of view in Context A.
Bits 10:0	X Zoom A. Must be \geq X Size A.
R167:1—0X1A7 - REDUCER HORIZONTAL OUTPUT SIZE—CONTEXT A (R/W)	
Default	0x0280
Description	Controls reducer horizontal output size in Context A.
Bits 10:0	X Size A. Must be \leq X Zoom A..
R168:1—0X1A8 - REDUCER VERTICAL PAN—CONTEXT A (R/W)	
Default	0x0000
Description	Controls reducer vertical pan in Context A.
Bit 14	0: MT9V111-compatible origin at Y = 0. 1: Centered origin at Y = 512 for more convenient zoom and resize.
Bits 10:0	Y Pan: unsigned offset from y = 0 (Bit 14 = 0), or two's complement from Y = 512 (Bit 14 = 1).
R169:1—0X1A9 - REDUCER VERTICAL ZOOM—CONTEXT A (R/W)	
Default	0x0400
Description	Controls reducer vertical height of zoom window for field of view in Context A.
Bits 10:0	Y Zoom A. Must be \geq Y Size A.
R170:1—0X1AA - REDUCER VERTICAL OUTPUT SIZE—CONTEXT A (R/W)	
Default	0x0200
Description	Controls reducer vertical output size in Context A.
Bits 10:0	Y SizeA. Must be \leq Y Zoom A.
R171:1—0X1AB - REDUCER CURRENT HORIZONTAL ZOOM (R/O)	
Default	N/A
Description	Current horizontal zoom.
Bits 10:0	Current Zoom Window Width. After automatic zoom (R175:1), copy R171:1 to the snapshot X Zoom register R166:1 (Context A) or R160:1 (Context B) so the snapshot has the same field of view as preview. Also copy to snapshot X Size register R167:1 (Context A) or R161 (Context B) for largest snapshot.
Bits 15:12	Reserved. Mask off these bits before performing the above copy operation.

Table 9: Colorpipe Register Description (continued)

R172:1—0X1AC - REDUCER CURRENT VERTICAL ZOOM (R/O)	
Default	N/A
Description	Current vertical zoom.
Bits 10:0	Current Zoom Window Height. After automatic zoom (R175:1), copy R172:1 to the snapshot Y Zoom register R169:1 (Context A) or R163:1 (Context B) so the snapshot will have the same field of view as preview. Also copy to snapshot X Size register R170:1 (Context A) or R164 (Context B) for largest snapshot.
Bits 15:12	Reserved. Mask off these bits before performing the above copy operation.
R174:1—0X1AE - REDUCER ZOOM STEP SIZE (R/W)	
Default	0x0504
Description	Zoom step sizes. Should be a multiple of the aspect ratio 5:4 for SXGA or 4:3 VGA or 11:9 for CIF.
Bits 15:8	Zoom step size in X.
Bits 7:0	Zoom step size in Y.
R175:1—0X1AF - REDUCER ZOOM CONTROL (R/W)	
Default	0x0010
Description	Resize interpolation and zoom control.
Bit 9	Starts automatic "zoom out" in step sizes defined in R174:1.
Bit 8	Starts automatic "zoom in" in step sizes defined in R174:1.
Bit 6	Reserved.
Bit 5	Reserved.
Bit 4	Reserved.
Bit 3	Auto switch to classic interpolation at full resolution.
Bit 1	Reserved.
Bit 0	Reserved.
R179:1—0X1B3 - GLOBAL CLOCK CONTROL (R/W)	
Default	0x0002
Description	Configures assorted aspects of the clock controller.
Bits 15:2	Not used.
Bit 1	Tri-states pins in standby mode.
Bit 0	SOC soft standby.
R200:1—0X1C8 - GLOBAL CONTEXT CONTROL (R/W)	
Default	0x0000
Description	Defines sensor and colorpipe context for current frame. Registers R200:0, R200:1, and R200:2 are shadows of each other. See description in R200:2. It is recommended that all updates to R200:n are handled by means of a write to R200:2.
Bit 15:0	See R200:2[15:0].
R226:1—0X1E2 - EFFECTS MODE (R/W)	
Default	0x7000
Description	This register specifies which of several special effects to apply to each pixel passing through the pixel pipe.
Bits 15:8	Solarization threshold.
Bits 2:0	Specification of the effects mode. "000"—No effect (pixels pass through unchanged). "001"—Monochrome (chromas set to 0). "010"—Sepia (chromas set to the value in the Effects Sepia register). "011"—Negative (all color channels inverted). "100"—Solarize (luma conditionally inverted). "101"—Solarize2 (luma conditionally inverted, chromas inverted when luma inverted).

Table 9: Colorpipe Register Description (continued)

R227:1—0X1E3 - EFFECTS SEPIA (R/W)	
Default	0xB023
Description	This register specifies the chroma values for the sepia effect. In sepia mode, the chroma values of each pixel are set to this value. By default, this register contains a brownish color, but it can be set to an arbitrary color.
Bit 15	Sign of Cb.
Bits 14:8	Magnitude of Cb in 0.7 fixed point.
Bit 7	Sign of Cr.
Bits 6:0	Magnitude of Cr in 0.7 fixed point.
R240:1—0X1F0 - PAGE MAP (R/W)	
Default	0x0000
Description	This register specifies the register address page for the two-wire interface protocol.
Bits 2:0	Page Address: "000"—Sensor address page "001"—Colorpipe address page "010"—Camera control address page
R241:1—0X1F1 - BYTE-WISE ADDRESS (R/W)	
Default	N/A
Description	Special address to perform 8-bit reads and writes to the sensor. For additional information, see "Two-Wire Serial Interface Sample" on page 57 and "APPENDIX A" on page 56.

Table 10: Camera Control Register Description

R38:2—0X226 - AUTO EXPOSURE WINDOW HORIZONTAL BOUNDARIES (R/W)	
Default	0x8000
Description	This register specifies the left and right boundaries of the window used by the auto exposure measurement engine. The values programmed in the registers are the fractional percentage, where 128 (decimal) is the right-most edge of the frame, 64 (decimal) is the middle of the frame, and 0 is the left-most edge of the frame.
Bits 15:8	Right window boundary.
Bits 7:0	Left window boundary.
R39:2—0X227 - AUTO EXPOSURE WINDOW VERTICAL BOUNDARIES (R/W)	
Default	0x8008
Description	This register specifies the top and bottom boundaries of the window used by the auto exposure measurement engine. The values programmed in the registers are the fractional percentage, where 128 (decimal) is the bottom edge of the frame, 64 (decimal) is the middle of the frame, and 0 is the top edge of the frame.
Bits 15:8	Bottom window boundary.
Bits 7:0	Top window boundary.
R43:2—0X22B - AUTO EXPOSURE CENTER WINDOW HORIZONTAL BOUNDARIES (R/W)	
Default	0x6020
Description	This register specifies the left and right boundaries of the window used by the auto exposure measurement engine in backlight compensation mode. The values programmed in the registers are the fractional percentage, where 128 (decimal) is the right-most edge of the frame, 64 (decimal) is the middle of the frame, and 0 is the left-most edge of the frame.
Bits 15:8	Right window boundary.
Bits 7:0	Left window boundary.
R44:2—0X22C - AUTO EXPOSURE CENTER WINDOW VERTICAL BOUNDARIES (R/W)	
Default	0x6020
Description	This register specifies the top and bottom boundaries of the window used by the auto exposure measurement engine in backlight compensation mode. The values programmed in the registers are the fractional percentage, where 128 (decimal) is the bottom edge of the frame, 64 (decimal) is the middle of the frame, and "0" is the top edge of the frame.
Bits 15:8	Bottom window boundary.
Bits 7:0	Top window boundary.
R45:2—0X22D - AWB WINDOW BOUNDARIES (R/W)	
Default	0xF0A0
Description	This register specifies the boundaries of the window used by the AWB measurement engine. Essentially, it describes the AWB measurement window in terms relative to the size of the image—horizontally, in units of 1/10ths of the width of the image; vertically, in units of 1/16 of the height of the image. So although the positioning is highly quantized, the window remains roughly in place as the resolution changes.
Bits 15:12	Bottom window boundary (in units of blocks).
Bits 11:8	Top window boundary (in units of blocks).
Bits 7:4	Right window boundary (in units of 2 blocks).
Bits 3:0	Left window boundary (in units of 2 blocks).
R46:2—0X22E - AUTO EXPOSURE TARGET AND PRECISION CONTROL (R/W)	
Default	0x0C4A
Description	This register specifies the luma target of the auto exposure algorithm and the size of the window/range around the target in which no auto exposure adjustment is made. This window is centered on target, but the value programmed in the register is 1/2 of the window size.
Bits 15:8	Half-size of the auto exposure stability window/range.
Bits 7:0	Luma value of the auto exposure target.

Table 10: Camera Control Register Description (continued)

R47:2—0X22F - AUTO EXPOSURE SPEED AND SENSITIVITY CONTROL—CONTEXT A (R/W)	
Default	0xDF20
Description	This register specifies the speed and sensitivity to changes of auto exposure in Context A.
Bit 15	Reserved.
Bit 14	Reserved.
Bits 13:12	Reserved.
Bit 11	Reserved.
Bit 10	Reserved.
Bit 9	Reserved.
Bits 8:6	Factor of reduction of the difference between current luma and target luma. In one adjustment auto exposure advances from current luma to target as follows: "000"—1/4 way going down, 1/8 going up. "001"—1/4 way in both directions. "010"—1/2 way in both directions. "011"—1/2 way going down, 1/4 going up. "100"—All the way in both directions (fast adaptation!). "101"—3/4 way in both directions. "110"—7/8 way in both directions. "111"—Reserved. Currently the same as "100"
Bit 5	Reserved
Bits 4:3	Auto exposure luma is updated every N frames, where N is given by this field.
Bits 2:0	Hysteresis control via time-averaged smoothing of luma data. Luma measurements for auto exposure are time-averaged as follows: "000"—Auto exposure luma = current luma. "001"—Auto exposure luma = 1/2 current luma + 1/2 buffered value. "010"—Auto exposure luma = 1/4 current luma + 3/4 buffered value. "011"—Auto exposure luma = 1/8 current luma + 7/8 buffered value. "100"—Auto exposure luma = 1/16 current luma + 15/16 buffered value. "101"—Auto exposure luma = 1/32 current luma + 31/32 buffered value. "110"—Auto exposure luma = 1/64 current luma + 63/64 buffered value. "111"—Auto exposure luma = 1/128 current luma + 127/128 buffered value.
R91:2—0X25B - FLICKER CONTROL (R/W)	
Default	0x0002
Description	Primary flicker control register.
Bit 15	(Read only) 50Hz/60Hz detected. 0: 50Hz detected. 1: 60Hz detected.
Bit 2	Reserved
Bit 1	When in "manual" flicker mode (R91:2[0] = 1), defines which flicker frequency to avoid. 0: Forces 50Hz detection. 1: Forces 60Hz detection.
Bit 0	0: Auto flicker detection. 1: Manual mode.
R98:2—0X262 - AUTO EXPOSURE DIGITAL GAINS MONITOR (R/W*)	
Default	N/A
Description	These digital gains are applied within the IFP; they are independent of the Imager gains.
Bits 15:8	Post-lens-correction digital gain (*writable if auto exposure is disabled).
Bits 7:0	Pre-lens-correction digital gain (*writable if auto exposure is disabled).

Table 10: Camera Control Register Description (continued)

R103:2—0X267 - AUTO EXPOSURE DIGITAL GAIN LIMITS (R/W)	
Default	0x4010
Description	This register specifies the upper limits of the digital gains used by the auto exposure algorithm. The values programmed to this register are 16 times the absolute gain values. The value of 16 represents the gain 1.0.
Bits 15:8	Maximum limit on post-lens-correction digital gain.
Bits 7:0	Maximum limit on pre-lens-correction digital gain.
R156:2—0X29C - AUTO EXPOSURE SPEED AND SENSITIVITY CONTROL—CONTEXT B (R/W)	
Default	0xDF20
Description	This register specifies the speed and sensitivity to auto exposure changes in Context B.
Bit 15	Reserved.
Bit 14	Reserved.
Bits 13:12	Reserved.
Bit 11	Reserved.
Bit 10	Reserved.
Bit 9	Reserved.
Bits 8:6	Factor of reduction of the difference between current luma and target luma. In one adjustment, auto exposure advances from current luma to target as follows: "000"—1/4 way going down, 1/8 going up. "001"—1/4 way in both directions. "010"—1/2 way in both directions. "011"—1/2 way going down, 1/4 going up. "100"—All the way in both directions (fast adaptation!). "101"—3/4 way in both directions. "110"—7/8 way in both directions. "111"—Reserved. Currently the same as "100."
Bit 5	Reserved.
Bits 4:3	Auto exposure luma is updated every N frames, where N is given by this field.
Bits 2:0	Hysteresis control via time-averaged smoothing of luma data. Luma measurements for auto exposure are time-averaged as follows: "000"—Auto exposure luma = current luma. "001"—Auto exposure luma = 1/2 current luma + 1/2 buffered value. "010"—Auto exposure luma = 1/4 current luma + 3/4 buffered value. "011"—Auto exposure luma = 1/8 current luma + 7/8 buffered value. "100"—Auto exposure luma = 1/16 current luma + 15/16 buffered value. "101"—Auto exposure luma = 1/32 current luma + 31/32 buffered value. "110"—Auto exposure luma = 1/64 current luma + 63/64 buffered value. "111"—Auto exposure luma = 1/128 current luma + 127/128 buffered value.
R180:2—RESERVED	
R200:2—0X2C8 - GLOBAL CONTEXT CONTROL (R/W)	
Default	0x0000
Description	Defines sensor and colorpipe context for current frame. Context A is typically used to define preview or viewfinder mode, while Context B is typically used for snapshots. The bits of this register <i>directly</i> control the respective functions, so care must be taken when writing to this register if a bad frame is to be avoided during the context switch.
Bit 15	Controls assertion of sensor restart on update of global context control register. This helps ensure that the very next frame is generated with the new context (a problem with regard to exposure due to the rolling shutter). This bit is automatically cleared once the restart has occurred. 0: Do not restart sensor. 1: Restart sensor.

Table 10: Camera Control Register Description (continued)

Bit 14	Reserved.
Bit 13	Reserved.
Bit 12	Defect correction context. See R76:1 and R77:1. 0: Context A 1: Context B
Bit 11	Reserved.
Bit 10	Resize/zoom context. Switch resize/zoom contexts: 0: Context A 1: Context B
Bit 9	Output format Control 2 context. See R58:1 and R155:1. 0: Context A 1: Context B
Bit 8	Gamma table context. 0: Context A 1: Context B
Bit 7	Arm Xenon Flash.
Bit 6	Blanking control. This is primarily for use by the internal sequencer when taking automated (e.g., flash) snapshots. Setting this bit stops frames from being sent over the BT656 external pixel interface. This is useful for ensuring that the desired frame during a snapshot sequence is the only frame captured by the host. 0: Do not blank frames to host. 1: Blank frames to host
Bit 5	Reserved.
Bit 4	Reserved.
Bit 3	Sensor read mode context (skip mode, power mode, see R33:0 and R32:0). 0: Context A 1: Context B
Bit 2	LED flash ON: 0: Turn off LED Flash 1: Turn on LED Flash
Bit 1	Vertical blanking context: 0: Context A 1: Context B
Bit 0	Horizontal blanking context: 0: Context A 1: Context B
R240:2—0X2F0 - PAGE MAP (R/W)	
Default	0x0000
Description	This register specifies the register address page for the two wire interface protocol.
Bits 2:0	Page address: "000"—Sensor address page. "001"—Colorpipe address page. "010"—Camera control address page.
R241:2—0X2F1 - BYTE-WISE ADDRESS (R/W)	
Default	N/A
Description	Special address to perform 8-bit reads and writes to the sensor. For additional information, see "Two-Wire Serial Interface Sample" on page 57 and "APPENDIX A" on page 56.

NOTE:

Registers marked "(R/W*)" are normally read-only (R/O) registers, except under special circumstances (detailed in the register description), when some or all bits of the register become read-writable (R/W).



Sensor Core Overview

The sensor consists of a pixel array of 1,316 x 1,048 total, an analog readout chain, 10-bit ADC with programmable gain and black offset, and timing and control.

Figure 5: Sensor Core Block Diagram

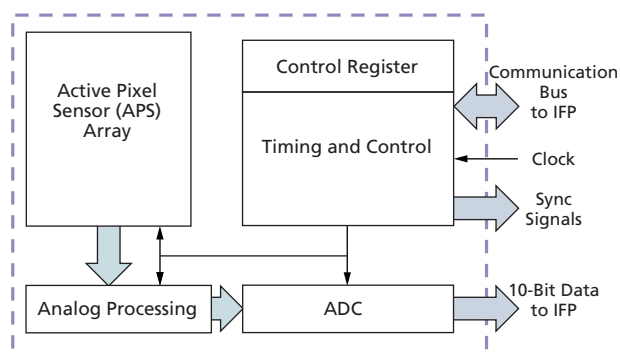

Pixel Data Format

Pixel Array Structure

The MT9M111 sensor core pixel array is configured as 1,316 columns by 1,048 rows (shown in Figure 6). The first 24 columns and the first 8 rows of pixels are optically black, and can be used to monitor the black level. The last 3 columns and the last 7 rows of pixels also are optically black. The black row data is used internally for the automatic black level adjustment. However, the first 8 black rows can also be read out by setting the sensor to raw data output mode (Reg0x022). There are 1,289 columns by 1,033 rows of optically-active pixels that provide a 4-pixel boundary around the SXGA (1,280 x 1,024) image to avoid boundary effects during color interpolation and correction. The additional active column and additional active row are used to enable horizontally and vertically mirrored readout to start on the same color pixel.

Figure 6: Pixel Array Description

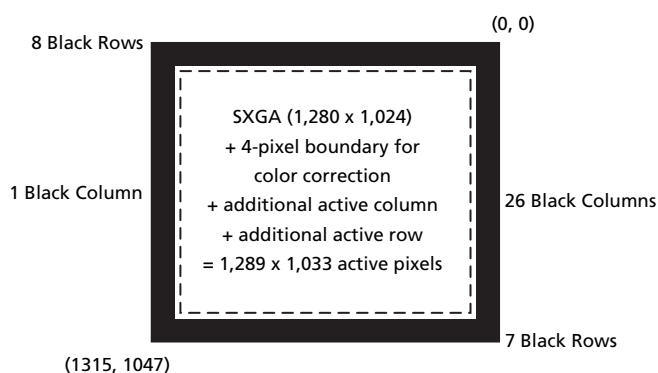

The MT9M111 sensor core uses an RGB Bayer color pattern, shown in Figure 7. The even-numbered rows contain green and red color pixels, and odd numbered rows contain blue and green color pixels. Even numbered columns contain green and blue color pixels; odd-numbered columns contain red and green color pixels. Because there are odd numbers of rows and columns, the color order can be preserved during mirrored readout.

Figure 7: Pixel Color Pattern Detail (Top Right Corner)

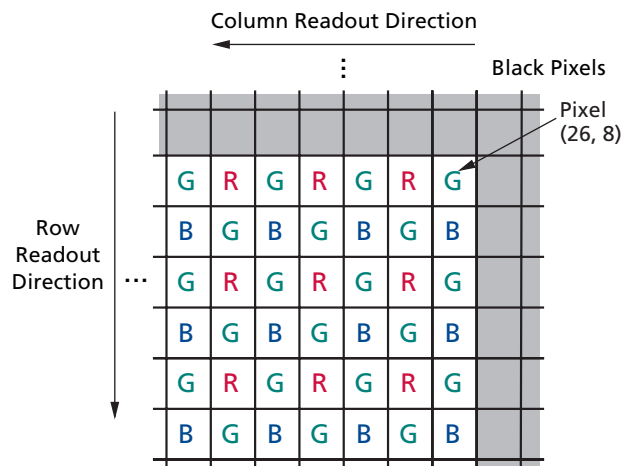



Output Data Format

The MT9M011 sensor core image data is read out in a progressive scan. Valid image data is surrounded by horizontal blanking and vertical blanking, shown in Figure 8. LINE_VALID is HIGH during the shaded region of the figure. FRAME_VALID timing is described in "APPENDIX A" on page 56.

Figure 8: Spatial Illustration of Image Readout

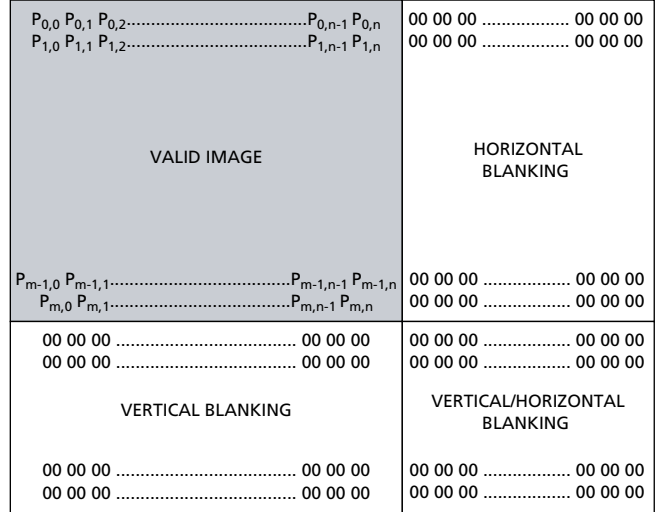

Sensor Core Register List
Table 11: Sensor Registers (Address Page 0)

REGISTER# DEC (HEX)	REGISTER NAME	DATA FORMAT	DEFAULT VALUE DEC (HEX)
0 (0x00)	Chip Version	0001 0100 0011 1010 (LSB)	5178 (0x143A)
1 (0x01)	Row Start	0000 0ddd dddd dddd	12 (0x000C)
2 (0x02)	Column Start	0000 0ddd dddd dddd	30 (0x001E)
3 (0x03)	Window Height	0000 0ddd dddd dddd	1024 (0x0400)
4 (0x04)	Window Width	0000 0ddd dddd dddd	1280 (0x0500)
5 (0x05)	Horizontal Blanking—Context B	00dd dddd dddd dddd	388 (0x0184)
6 (0x06)	Vertical Blanking—Context B	0ddd dddd dddd dddd	42 (0x002A)
7 (0x07)	Horizontal Blanking—Context A	00dd dddd dddd dddd	190 (0x00BE)
8 (0x08)	Vertical Blanking—Context A	0ddd dddd dddd dddd	17 (0x0011)
9 (0x09)	Shutter Width	dddd dddd dddd dddd	537 (0x0219)
10 (0x0A)	Row Speed	ddd0 000d dddd dddd	17 (0x0011)
11 (0x0B)	Extra Delay	00dd dddd dddd dddd	0 (0x0000)
12 (0x0C)	Shutter Delay	00dd dddd dddd dddd	0 (0x0000)
13 (0x0D)	Reset	d000 00dd 00dd dddd	8 (0x0008)
32 (0x20)	Read Mode—Context B	dd00 0ddd dddd dddd	768 (0x0300)
33 (0x21)	Read Mode—Context A	0000 0d00 0000 dd00	1036 (0x040C)
34 (0x22)	Reserved	—	297 (0x0129)
35 (0x23)	Flash Control	??dd dddd dddd dddd	1544 (0x0608)
36 (0x24)	Reserved	—	32875 (0x806B)
43 (0x2B)	Green1 Gain	0000 0ddd dddd dddd	32 (0x0020)
44 (0x2C)	Blue Gain	0000 0ddd dddd dddd	32 (0x0020)
45 (0x2D)	Red Gain	0000 0ddd dddd dddd	32 (0x0020)
46 (0x2E)	Green2 Gain	0000 0ddd dddd dddd	32 (0x0020)
47 (0x2F)	Global Gain	0000 0ddd dddd dddd	32 (0x0020)
48 (0x30)	Reserved	—	1066 (0x042A)
49 (0x31)	Reserved	—	7168 (0x1C00)
50 (0x32)	Reserved	—	0 (0x0000)
51 (0x33)	Reserved	—	841 (0x0349)
52 (0x34)	Reserved	—	49177 (0xC019)
54 (0x36)	Reserved	—	61680 (0xF0F0)
55 (0x37)	Reserved	—	0 (0x0000)
59 (0x3B)	Reserved	—	33 (0x0021)
60 (0x3C)	Reserved	—	6688 (0x1A20)
61 (0x3D)	Reserved	—	8222 (0x201E)
62 (0x3E)	Reserved	—	8224 (0x2020)
63 (0x3F)	Reserved	—	8224 (0x2020)
64 (0x40)	Reserved	—	8220 (0x201C)
65 (0x41)	Reserved	—	215 (0x00D7)
66 (0x42)	Reserved	—	1911 (0x0777)
89 (0x59)	Reserved	—	12 (0x000C)
90 (0x5A)	Reserved	—	49167 (0xC00F)
91 (0x5B)	Reserved	—	N/A

Table 11: Sensor Registers (Address Page 0) (continued)

REGISTER# DEC (HEX)	REGISTER NAME	DATA FORMAT	DEFAULT VALUE DEC (HEX)
92 (0x5C)	Reserved	—	N/A
93 (0x5D)	Reserved	—	N/A
94 (0x5E)	Reserved	—	N/A
95 (0x5F)	Reserved	—	8989 (0x231D)
96 (0x60)	Reserved	—	128 (0x0080)
97 (0x61)	Reserved	—	0 (0x0000)
98 (0x62)	Reserved	—	0 (0x0000)
99 (0x63)	Reserved	—	0 (0x0000)
100 (0x64)	Reserved	—	0 (0x0000)
101 (0x65)	Reserved	—	0 (0x0000)
112 (0x70)	Reserved	—	31498 (0x7B0A)
113 (0x71)	Reserved	—	31498 (0x7B0A)
114 (0x72)	Reserved	—	6414 (0x190E)
115 (0x73)	Reserved	—	6159 (0x180F)
116 (0x74)	Reserved	—	22322 (0x5732)
117 (0x75)	Reserved	—	22068 (0x5634)
118 (0x76)	Reserved	—	29493 (0x7335)
119 (0x77)	Reserved	—	12306 (0x3012)
120 (0x78)	Reserved	—	30978 (0x7902)
121 (0x79)	Reserved	—	29958 (0x7506)
122 (0x7A)	Reserved	—	30474 (0x770A)
123 (0x7B)	Reserved	—	30729 (0x7809)
124 (0x7C)	Reserved	—	32006 (0x7D06)
125 (0x7D)	Reserved	—	12560 (0x3110)
126 (0x7E)	Reserved	—	126 (0x007E)
128 (0x80)	Reserved	—	127 (0x007F)
129 (0x81)	Reserved	—	127 (0x007F)
130 (0x82)	Reserved	—	22282 (0x570A)
131 (0x83)	Reserved	—	22539 (0x580B)
132 (0x84)	Reserved	—	18188 (0x470C)
133 (0x85)	Reserved	—	18446 (0x480E)
134 (0x86)	Reserved	—	23298 (0x5B02)
135 (0x87)	Reserved	—	92 (0x005C)
200 (0xC8)	Context Control	d000 0000 d000 dddd	0 (0x0000)
240 (0xF0)	Page Map	0000 0000 0000 0ddd	0 (0x0000)
241 (0xF1)	Byte-Wise Address	Reserved	Reserved
245 (0xF5)	Reserved	—	2047 (0x07FF)
246 (0xF6)	Reserved	—	2047 (0x07FF)
247 (0xF7)	Reserved	—	0 (0x0000)
248 (0xF8)	Reserved	—	0 (0x0000)
249 (0xF9)	Reserved	—	124 (0x007C)
250 (0xFA)	Reserved	—	0 (0x0000)
251 (0xFB)	Reserved	—	0 (0x0000)
252 (0xFC)	Reserved	—	0 (0x0000)
253 (0xFD)	Reserved	—	0 (0x0000)

Table 11: Sensor Registers (Address Page 0) (continued)

REGISTER# DEC (HEX)	REGISTER NAME	DATA FORMAT	DEFAULT VALUE DEC (HEX)
255 (0xFF)	Chip Version	0001 0100 0011 1010	5178 (0x143A)

NOTE:

Data Format Key:

0 = "Don't Care" bit

d = R/W bit

? = R/O bit. The exceptions: R0:0 and R255:0, which are hardwired R/O binary values.

Sensor Core Register Descriptions
Table 12: Sensor Core Register Descriptions

BIT FIELD	DESCRIPTION	DEFAULT (HEX)	SYNCED TO FRAME START	BAD FRAME	READ/ WRITE
R0:0—0X000 - CHIP VERSION (R/O)					
Bits 15:0	Hardwired read-only.	0x143A			R
R1:0—0X001 - ROW START					
Bits 10:0 Row Start	The first row to be read out (not counting dark rows that may be read). To window the image down, set this register to the starting Y value. Setting a value less than 8 is not recommended since the dark rows should be read using Reg0x022.	0xC	Y	YM	W
R2:0—0X002 - COLUMN START					
Bits 10:0 Col Start	The first column to be read out (not counting dark columns that may be read). To window the image down, set this register to the starting X value. Setting a value below 0x18 is not recommended since readout of dark columns should be controlled by Reg0x022.	0x1E	Y	YM	W
R3:0—0X003 - WINDOW HEIGHT					
Bits 10:0 Window Height	Number of rows in the image to be read out (not counting dark rows or border rows that may be read).	0x400	Y	YM	W
R4:0—0X004 - WINDOW WIDTH					
Bits 10:0 Window Width	Number of columns in image to be read out (not counting dark columns or border columns that may be read).	0x500	Y	YM	W
R5:0—0X005 - HORIZONTAL BLANKING—CONTEXT B					
Bits 10:0 Horizontal Blanking B	Number of blank columns in a row when Context B is chosen (bit 0, Reg0x0C8 = 1). If set smaller than the minimum value, the minimum value is used. With default settings, the minimum horizontal blanking is 202 columns in full-power readout mode and 114 columns in low-power readout mode.	0x184	Y	YM	W
R6:0—0X006 - VERTICAL BLANKING—CONTEXT B					
Bits 14:0 Vertical Blanking B	Number of blank rows in a frame when Context B is chosen (bit 1, Reg0x0C8 = 1). This number must be equal to or larger than the number of dark rows read out in a frame specified by Reg0x022.	0x2A	Y	N	W
R7:0—0X007 - HORIZONTAL BLANKING—CONTEXT A					
Bits 10:0 Horizontal Blanking A	Number of blank columns in a row when Context A is chosen (bit 0, Reg0x0C8 = 0). The extra columns are added at the beginning of a row. If set smaller than the minimum value, the minimum value is used. With default settings, the minimum horizontal blanking is 202 columns in full-power readout mode and 114 columns in low-power readout mode.	0xBE	Y	YM	W
R8:0—0X008 - VERTICAL BLANKING—CONTEXT A					

Table 12: Sensor Core Register Descriptions (continued)

BIT FIELD	DESCRIPTION	DEFAULT (HEX)	SYNCED TO FRAME START	BAD FRAME	READ/ WRITE
Bits 14:0 Vertical Blanking A	Number of blank rows in a frame when Context A is chosen (bit 1, Reg0x0C8 = 1). This number must be equal to or larger than the number of dark rows read out in a frame specified by Reg0x022.	0x11	Y	N	W
R9:0—0X009 - SHUTTER WIDTH					
Bits 15:0 Shutter Width	Integration time in number of rows. In addition to this register, the shutter delay register (Reg0x0C) and the overhead time influences the integration time for a given row time.	0x219	Y	N	W
R10:0—0X00A - ROW SPEED					
Bits 15:13	Reserved.	—	—	—	—
Bit 8 Invert Pixel Clock	Invert pixel clock. When set, LINE_VALID, FRAME_VALID, and DATA_OUT are set to the falling edge of PIXCLK. When clear, they are set to the rising edge if there is no pixel clock delay.	0x0	N	0	W
Bits 7:4 Delay Pixel Clock	Delay PIXCLK in half-master-clock cycles. When set, the pixel clock can be delayed in increments of half-master-clock cycles compared to the synchronization of FRAME_VALID, LINE_VALID, and DATA_OUT.	0x1	N	0	W
Bits 3:0 Pixel Clock Speed	Pixel clock period in master clocks when full-power readout mode is used (Reg0x020/0x021, bit 10 = 0). In this case, the ADC clock has twice the clock period. If low-power readout mode is used, the pixel clock period is automatically doubled, so the ADC clock period remains the same for one programmed register value. The value "0" is not allowed, and "1" is used instead.	0x1	Y	YM	W
R11:0—0X00B - EXTRA DELAY					
Bits 13:0 Extra Delay	Extra blanking inserted between frames specified in pixel clocks. Can be used to get a more exact frame rate. For integration times less than a frame, however, it might affect the integration times for parts of the image.	0x0	Y	0	W
R12:0—0X00C - SHUTTER DELAY					
Bits 10:0 Shutter Delay	The amount of time from the end of the sampling sequence to the beginning of the pixel reset sequence. This variable is automatically halved in low-power readout mode, so the time in use remains the same. This register has an upper value defined by the fact that the reset needs to finish prior to readout of that row to prevent changes in the row time.	0x0	Y	N	W
R13:0—0X00D - RESET					
Bit 15 Synchronize Changes	0: Normal operation, updates changes to registers that affect image brightness at the next frame boundary (integration time, integration delay, gain, horizontal blanking and vertical blanking, window size, row/column skip, or row mirror. 1: Do not update any changes to these settings until this bit is returned to "0." All registers that are frame synchronized are affected by this bit setting.	0x0	N	0	W
Bit 9 Restart Bad Frames	When set, a forced restart occurs when a bad frame is detected. This can shorten the delay when waiting for a good frame because the delay when masking out a bad frame is the integration time rather than the full frame time.	0x0	N	0	W

Table 12: Sensor Core Register Descriptions (continued)

BIT FIELD	DESCRIPTION	DEFAULT (HEX)	SYNCED TO FRAME START	BAD FRAME	READ/ WRITE
Bit 8 Show Bad Frames	0: Only output good frames (default) A bad frame is defined as the first frame following a change to: window size or position, horizontal blanking, pixel clock speed, zoom, row or column skip, or mirroring. 1: Output all frames (including bad frames)	0x0	N	0	W
Bit 5 Reset SOC	This reset signal is fed directly to the SOC part of the chip, and has no functionality in a stand-alone sensor.	0x0	N	0	W
Bit 4 Output Disable	When set, the output pins are tri-stated.	0x0	N	0	W
Bit 3 Chip Enable	0: Stop sensor readout. 1: Normal operation. When this is returned to "1," sensor readout restarts and begins resetting the starting row in a new frame. To reduce the digital power, the master clock to the sensor can be disabled or the standby pin can be used.	0x1	N	YM	W
Bit 2 Analog Standby	0: Normal operation (default) 1: Disable analog circuitry. Whenever this bit is set to "1" the chip enable bit (bit 3) should be set to "0."	0x0	N	YM	W
Bit 1 Restart	Setting this bit causes the sensor to abandon the current frame and start resetting the first row. The delay before the first valid frame is read out equals the integration time. This bit always reads "0."	0x0	N	YM	W
Bit 0 Reset	Setting this bit puts the sensor in reset mode; this sets the sensor to its default power-up state. Clearing this bit resumes normal operation.	0x0	N	YM	W
R32:0—0X020 - READ MODE—CONTEXT B					
Bit 15 XOR Line Valid	0: LINE_VALID determined by bit 9. Ineffective if "Continuous" LINE_VALID is set. 1: LINE_VALID = Continuous LINE_VALID XOR FRAME_VALID.	0x0	N	0	W
Bit 14 Continuous Line Valid	0: Normal LINE_VALID (default, no line valid during vertical blanking). 1: "Continuous" LINE_VALID (continue producing LINE_VALID during vertical blanking).	0x0	N	0	W
Bit 10 Power Readout Mode—Context B	When read mode Context B is selected (bit 3, Reg0x0C8 = 1): 0: Full-power readout mode, maximum readout speed. 1: Low-power readout mode. Maximum readout frequency is now half of the master clock, and the pixel clock is automatically adjusted as described for the pixel clock speed register.	0x0	Y	YM	W
Bit 9 Show Border	This bit indicates whether to show the border enabled by bit 8. When bit 8 is 0, this bit has no meaning. When bit 8 is 1, this bit decides whether the border pixels should be treated as extra active pixels (1) or extra blanking pixels (0).	0x1	N	0	W
Bit 8 Over Sized	When this bit is set, a 4-pixel border is output around the active image array independent of readout mode (skip, zoom, mirror, etc.). Setting this bit therefore adds eight to the numbers of rows and columns in the frame.	0x1	Y	YM	W
Bits 7:6	Reserved.	0x0	Y	YM	W

Table 12: Sensor Core Register Descriptions (continued)

BIT FIELD	DESCRIPTION	DEFAULT (HEX)	SYNCED TO FRAME START	BAD FRAME	READ/ WRITE
Bit 5 Column Skip 4x	0: Normal readout. 1: Readout two columns, and then skip six columns (as with rows).	0x0	Y	YM	W
Bit 4 Row Skip 4x	0: Normal readout. 1: Readout two rows, and then skip six rows (i.e., row 8, row 9, row 16, row 17...).	0x0	Y	YM	W
Bit 3 Column Skip 2x—Context B	When read mode Context B is selected (bit 3, Reg0x0C8 = 1): 0: Normal readout. 1: Readout two columns, and then skip two columns (as with rows).	0x0	Y	YM	W
Bit 2 Row Skip 2x—Context B	When read mode Context B is selected (bit 3, Reg0x0C8 = 1): 0: Normal readout. 1: Readout two rows, then skip two rows (i.e., row 8, row 9, row 12, row 13...).	0x0	Y	YM	W
Bit 1 Mirror Columns	Readout columns from right to left (mirrored). When set, column readout starts from column (Col Start + Col Size) and continues down to (Col Start + 1). When clear, readout starts at Col Start and continues to (Col Start + Col Size - 1). This ensures that the starting color is maintained.	0x0	Y	YM	W
Bit 0 Mirror Rows	Readout rows from bottom to top (upside down). When set, row readout starts from row (Row Start + Row Size) and continues down to (Row Start + 1). When clear, readout starts at Row Start and continues to (Row Start + Row Size - 1). This ensures that the starting color is maintained.	0x0	Y	YM	W
R33:0—0X021 - READ MODE—CONTEXT A					
Bit 10 Power Readout Mode—Context A	When read mode Context A is selected (bit 3, Reg0x0C8 = 0): 0: Full-power readout mode, maximum readout speed. 1: Low-power readout mode. Maximum readout frequency is now half of the master clock, and the pixel clock is automatically adjusted as described for the pixel clock speed register.	0x1	Y	YM	W
Bit 3 Column Skip 2x—Context A	When read mode Context A is selected (bit 3, Reg0x0C8 = 0): 0: Normal readout. 1: Readout two columns, and then skip two columns (as with rows).	0x1	Y	YM	W
Bit 2 Row Skip 2x—Context A	When read mode Context A is selected (bit 3, Reg0x0C8 = 0): 0: Normal readout. 1: Readout two rows, and then skip two rows (i.e., row 8, row 9, row 12, row 13...).	0x1	Y	YM	W
R35:0—0X023 - FLASH CONTROL					
Bit 15 Flash Strobe	Read-only bit that indicates whether the FLASH_STROBE pin is enabled.	0x0	0	0	R
Bit 14	Reserved.	—	—	—	—
Bit 13 Xenon Flash	Enable Xenon flash. When set, the FLASH_STROBE output pin is pulsed HIGH for the programmed period during vertical blanking. This is achieved by keeping the integration time equal to one frame and the pulse width less than the vertical blanking time.	0x0	Y	N	W
Bits 12:11 Frame Delay	Delay of the flash pulse measured in frames.	0x0	N	N	W

Table 12: Sensor Core Register Descriptions (continued)

BIT FIELD	DESCRIPTION	DEFAULT (HEX)	SYNCED TO FRAME START	BAD FRAME	READ/ WRITE
Bit 10 End of Reset	0: In Xenon mode, the flash should be enabled after the readout of a frame. 1: In Xenon mode, the flash should be triggered after the resetting of a frame.	0x1	N	N	W
Bit 9 Every Frame	0: Flash should be enabled for one frame only. 1: Flash should be enabled every frame.	0x1	N	N	W
Bit 8 LED Flash	Enables LED flash. When set, the FLASH_STROBE goes on prior to the start of a frame reset. When disabled, the FLASH_STROBE remains HIGH until readout of the current frame completes.	0x0	Y	Y	W
Bits 7:0 Xenon Count	Length of FLASH_STROBE pulse when Xenon flash is enabled. The value specifies the length in 1,024 master clock cycle increments.	0x08	N	N	W
R43:0—0X02B - GREEN1 GAIN					
Bits 6:0 Initial Gain	Initial gain = bits (6:0) x 0.03125.	0x20	Y	N	W
Bits 8:7 Analog Gain	Analog gain = (Bit 8 + 1) x (Bit 7 + 1) x initial gain (each bit gives 2x gain).	0x0	Y	N	W
Bits 10:9 Digital Gain	Total gain = (Bit 9 + 1) x (Bit 10 + 1) x analog gain (each bit gives 2x gain).	0x0	Y	N	W
R44:0—0X02C - BLUE GAIN					
Bits 10:9 Digital Gain	Total gain = (Bit 9 + 1) x (Bit 10 + 1) x analog gain (each bit gives 2x gain).	0x0	Y	N	W
Bits 8:7 Analog Gain	Analog gain = (Bit 8 + 1) x (Bit 7 + 1) x initial gain (each bit gives 2x gain).	0x0	Y	N	W
Bits 6:0 Initial Gain	Initial gain = bits (6:0) x 0.03125.	0x20	Y	N	W
R45:0—0X02D - RED GAIN					
Bits 10:9 Digital Gain	Total gain = (Bit 9 + 1) x (Bit 10 + 1) x analog gain (each bit gives 2x gain).	0x0	Y	N	W
Bits 8:7 Analog Gain	Analog gain = (Bit 8 + 1) x (Bit 7 + 1) x initial gain (each bit gives 2x gain).	0x0	Y	N	W
Bits 6:0 Initial Gain	Initial gain = bits (6:0) x 0.03125.	0x20	Y	N	W
R46:0—0X02E - GREEN2 GAIN					
Bits 10:9 Digital Gain	Total gain = (Bit 9 + 1) x (Bit 10 + 1) x analog gain threshold (each bit gives 2x gain).	0x0	Y	N	W
Bits 8:7 Analog Gain	Analog gain = (Bit 8 + 1) x (Bit 7 + 1) x initial gain (each bit gives 2x gain).	0x0	Y	N	W
Bits 6:0 Initial Gain	Initial gain = bits (6:0) x 0.03125.	0x20	Y	N	W
R47:0—0X02F - GLOBAL GAIN					
Bits 10:0 Global Gain	This register can be used to set all four gains at once. When read, it returns the value stored in Reg0x2B.	0x20	Y	N	W
R200:0—0X0C8 - CONTEXT CONTROL					

Table 12: Sensor Core Register Descriptions (continued)

BIT FIELD	DESCRIPTION	DEFAULT (HEX)	SYNCED TO FRAME START	BAD FRAME	READ/ WRITE
Bit 15 Restart	Setting this bit causes the sensor to abandon the current frame and start resetting the first row. Same physical register as Reg0x00D, bit 1.	0x0	N	YM	W
Bit 7 Xenon Flash Enable	Enable Xenon flash. Same physical register as Reg0x023, bit 13.	0x0	Y	N	W
Bit 3 Read Mode Select	0: Use read mode, Context A, Reg0x021. 1: Use read mode, Context B, Reg0x020. Note that bits found only in the read mode Context B register is always taken from that register.	0x0	Y	YM	W
Bit 2 LED Flash Enable	Enable LED flash. Same physical register as Reg0x023, bit 8.	0x0	Y	Y	W
Bit 1 Vertical Blanking Select	0: Use vertical blanking, Context A, Reg0x008 1: Use vertical blanking, Context B, Reg0x006.	0x0	Y	YM	W
Bit 0 Horizontal Blanking Select	0: Use horizontal blanking, Context A, Reg0x007. 1: Use horizontal blanking, Context B, Reg0x005.	0x0	Y	YM	W
R240:0—0X0F0 - PAGE MAP					
Bits 2:0 Page Map	Page mapping register. Must be kept at 0 to be able to write to/read from sensor. Used in the SOC to access other pages with registers.	0x0	N	0	W
R241:0—0X0F1 - BYTE-WISE ADDRESS					
Bit 0 Byte-Wise Address	Special address to perform 8-bit (instead of 16-bit) reads and writes to the sensor. For additional information, see "Two-Wire Serial Interface Sample" on page 57 and "APPENDIX A" on page 56.	N/A	0	0	0
R255:0—0X0FF - CHIP VERSION (R/O)					
Bits 15:0	Hardwired value.	0x143A			R

NOTE:

Notation used in the sensor core register description table:**Sync'd to frame start**

0 = Not applicable, e.g., read-only register.

N = No. The register value is updated and used immediately.

Y = Yes. The register value is updated at next frame start as long as the synchronize-changes bit is 0. Note also that frame start is defined as when the first dark row is read out. By default, this is 8 rows before FRAME_VALID goes HIGH.

Bad frame

A bad frame is a frame where all rows do not have the same integration time, or offsets to the pixel values changed during the frame.

0 = Not applicable, e.g., read-only register.

N = No. Changing the register value does not produce a bad frame.

Y = Yes. Changing the register value might produce a bad frame.

YM = Yes, but the bad frame is masked out unless the "show bad frames" feature is enabled.

Read/Write

R—Read-only register/bit.

W—Read/write register/bit.



Sensor Read Modes and Timing

This section provides an overview of typical usage modes for the MT9M111. It focuses on two primary configurations: the first is suitable for low-power view-finding, the second for full-resolution snapshots. It also describes mechanisms for switching between these modes.

Contexts

The MT9M111 supports hardware-accelerated context switching. A number of parameters have two copies of their setup registers; this allows two “contexts” to be loaded at any given time. These are referred to as Context A and Context B. Context selection for any single parameter is determined by the Global Context Control Register (GCCR, see R200:2). There are copies of this register in each address page. A write to any one of them has the identical effect. However, a READ from address page 0 only returns the subset bits of R200 that are specific to the sensor core.

The user can employ contexts for a variety of purposes; thus the generic naming convention. One typical usage model is to define Context A as “viewfinder” or “preview” mode and Context B as “snapshot” mode. The device defaults are configured with this in mind. This mechanism enables the user to have settings for viewfinder and snapshot modes loaded at the same time, and then switch between them with a single write to e.g. R200:2.

Viewfinder/Preview and Full-Resolution/Snapshot Modes

In the MT9M111, the sensor core supports two primary readout modes: low-power preview mode and full-resolution snapshot mode.

Low-Power Preview Mode

QSXGA (640 x 512) images are generated at up to 30 fps. The reduced-size images are generated by skipping pixels in the sensor, i.e. decimation. The key sensor registers that define this mode are Read Mode Context A Register (R33:0) and Read Mode Context B Register (R32:0). Only certain bits in these registers are context switchable; any bits that do not have multiple contexts are always defined by their values in R32:0. Any active sets of these registers are defined by the state of R200:n[3]. On reset, R200:n[3] = 0 selecting R33:0; setups specific to preview are defined by this register.

Full-Resolution Snapshot Mode

SXGA (1,280 x 1,024) images are generated at up to 15 fps. This is typically selected by setting R200:n[3] = 1 selecting R32:0 (Context B) as the primary read mode register.

Switching Modes

Typically, switching to full-resolution or snapshot mode is achieved by writing R200:2 = 0x9F0B. This restarts the sensor and sets most contexts to Context B. Following this write, a READ from R200:1 or R200:2 results in 0x1F0B being read. Note that the most significant bit (MSB) is cleared automatically by the sensor. A READ from R200:0 results in 0x000B, as only the lower 4 bits and the restart MSB are implemented in the sensor core.

Clocks

The sensor core is a master in the system. The sensor core frame rate defines the overall image flow pipeline frame rate. Horizontal and vertical blanking are influenced by the sensor configuration, and are also a function of certain IFP functions—particularly resize. The relationship of the primary clocks are depicted in Figure 9.

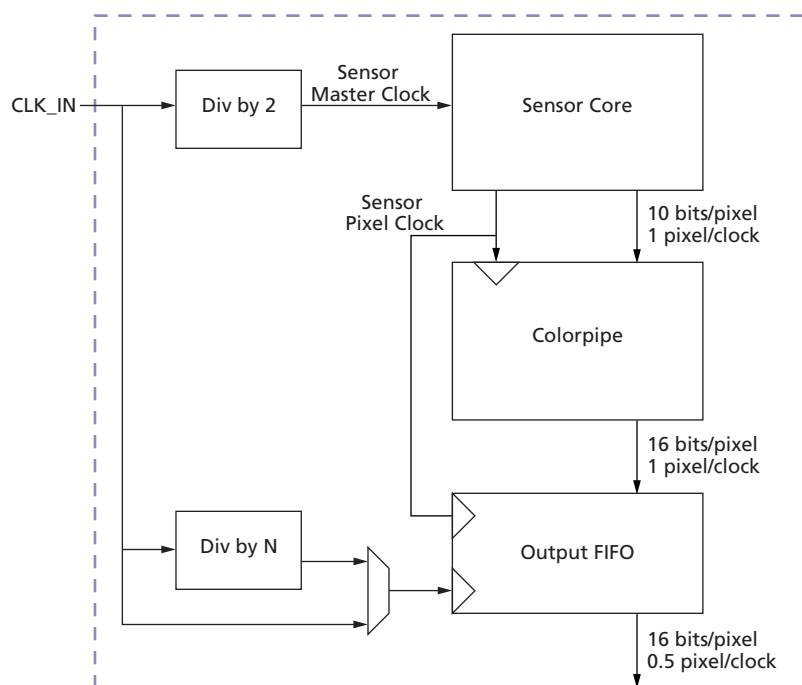
Figure 9: Primary Sensor Core Clock Relationships

The IFP typically generates up to 16 bits per pixel, for example YCbCr or RGB565, but has only an 8-bit port through which to communicate this pixel data. There is no phase locked loop (PLL), so the primary input clock (CLKIN) must be twice the fundamental pixel rate (defined by the sensor pixel clock).

To generate SXGA images at 15 fps, the sensor core requires a clock in the 24 MHz to 27 MHz range; this is also the fundamental pixel clock rate (sensor pixel clock) for full-power operation. To achieve this pixel rate, CLKIN must be in the 48 MHz to 54 MHz range. The device defaults assume a 54 MHz clock. Minimum clock frequency is 2 MHz.

Primary Operating Modes

The MT9M111 supports two primary modes of operation with respect to the sensor core that affect pixel rate, frame rate and blanking:

Full-Power Readout Mode

The sensor is in full-resolution mode, generating 1.3 megapixels (SXGA = 1,280 x 1,024 + border) for interpolation. The SXGA image fed from the sensor to the colorpipe can be resized in the colorpipe, but the frame rate is still defined by sensor core operation. In full-power readout mode, with full field of view, the frame rate is invariant with the final image size:

Context	Typically Context B
Sensor read mode settings	No skipping Full-power readout, i.e., full data rate
Sensor pixel clock	27 MHz for 54 MHz master clock: Maximum pixel rate of 27 megapixels/s
MAX frame rate	For 54 MHz master clock, 15 fps



Low-Power Readout Mode

Running under low-power readout, the sensor is in skip mode, and generates QSXGA frames (640 x 512 + border = 336,960 pixels). This full field of view QSXGA image can be resized, but only to resolutions smaller than QSXGA. The frame rate is defined by the operating mode of the sensor:

Context	Typically Context A
Sensor read mode settings	Row skip 2x Column skip 2x Low-power readout maximum data rate is half that of full-power readout
Sensor pixel clock	13.5 MHz for 54 MHz master clock: Maximum pixel rate of 13.5 megapixels/s
Maximum frame rate	For 54 MHz master clock, 30 fps

Tuning Frame Rates

Actual frame rates can be tuned by adjusting various sensor parameters. The sensor registers are in page 0, thus the “:0” after each register address:

Table 13: Register Address Functions

REGISTER	FUNCTION
R0x04:0	Window Width, typically 1,280 in the MT9M111
R0x03:0	Window Height, typically 1,024 in the MT9M111
LOW-POWER READOUT MODE—CONTEXT A	
R0x07:0	Horizontal blanking, default is 190 (units of sensor pixel clocks)
R0x08:0	Vertical blanking, default is 17 (rows including black rows)
FULL-POWER READOUT MODE—CONTEXT B	
R0x05:0	Horizontal blanking, default is 388 (units of sensor pixel clocks)
R0x06:0	Vertical blanking, default is 42 (rows including black rows)

In the MT9M111, the sensor core adds four border pixels all the way around the image, taking the active image size to 1,288 x 1,032 in full-power Snapshot resolution, and 648 x 520 when skipping rows in low-power preview resolution. This is achieved through the default settings:

- Read mode Context B: R0x20:0
- Oversize and show border bits are set by default.
- Oversize and show border bits are not context switchable, thus their location only in read mode Context B.

Default Blanking Calculations

The MT9M111 default blanking calculations are a function of context, as follows:

[REG<a> | REG]:

- Reg<a>
Low-power readout = Context A, typically used for viewfinder
- Reg
Full power readout = Context B, typically used for snapshots

Table 14: Blanking Parameter Calculations

PARAMETER	CALCULATION
PC_PERIOD Sensor Pixel Clock Period	Full-power readout: $(2/54)\mu\text{s} = 0.0370\mu\text{s}$ Low-power readout: $(4/54)\mu\text{s} = 0.0185\mu\text{s}$
A: Active Data Time (per line): $R0x04:0 + 8 \text{ (border)} * PC_PERIOD$	Full-power readout: $A = 1288 * (2/54)\mu\text{s} = 47.704\mu\text{s}$ Low-power readout: $A = 648 * (4 / 54)\mu\text{s} = 48.000 \mu\text{s}$
Q: Horizontal Blanking: $[R0x05:0 R0x07:0] * PC_PERIOD$	Full-power readout: $Q = 388 * (2/54)\mu\text{s} = 14.370\mu\text{s}$ Low-power readout: $Q = 190 * (4/54)\mu\text{s} = 14.074\mu\text{s}$
Row Time = Q + A:	Full-power readout: $62.074\mu\text{s}$ Low-power readout: $62.074\mu\text{s}$
P: Frame Start / End Blanking: $6 * PC_PERIOD$	Full-power readout: $P = 6 * (2/54)\mu\text{s} = 0.222\mu\text{s}$ Low-power readout: $P = 6 * (4 / 54)\mu\text{s} = 0.444\mu\text{s}$
V: Vertical Blanking: $[R0x06:0 R0x08:0] * (Q + A) + (Q - 2 * P)$	Full-power readout: $V = (42 * 62.074) + (14.370 - 0.444) = 2621.034 \mu\text{s}$ Low-power readout: $V = (17 * 62.074) + (14.074 - 0.888) = 1068.444 \mu\text{s}$
F: Total Frame Time: $(R0x03:0 + [R0x06:0 R0x08:0]) * (A + Q)$	Full-power readout: $V = (1032 + 42) * 62.074\mu\text{s} = 66667.476\mu\text{s} \geq 15 \text{ fps}$ Low-power readout: $V = (520 + 17) * 62.074\mu\text{s} = 33333.738\mu\text{s} \geq 30 \text{ fps}$

NOTE:

The line rate (row rate) is the same for both low-power and full-power readout modes. This ensures that when switching modes, exposure time does not change; the pre-existing shutter width remains valid.

User Blanking Calculations

When calculating blanking for different clock rates, minimum values for horizontal blanking and vertical blanking must be taken into account. Table 15 shows minimum values for each register

Table 15: User Blanking Minimum Values

PARAMETER	REGISTER	MINIMUM
Horizontal Blanking	Full-power readout (Context B): R0x05:0	202 (sensor pixel clocks)
	Low-power readout (Context A): R0x07:0	114 (sensor pixel clocks)
Vertical Blanking	Full-power readout (Context B): R0x06:0	5 (rows)
	Low-power readout (Context A): R0x08:0	5 (rows)



Exposure and Sensor Context Switching

The MT9M111 incorporates device setup features that prevent changes in sensor context from causing a change in exposure when switching between preview/viewfinder and full-resolution/snapshot modes. This is achieved by keeping the line rate consistent between modes.

Exposure

Defined by the shutter width. This is the number of lines to be reset before starting a frame read. If line rate does not change when a mode changes, exposure does not change.

Switching From Context A to B

Under typical/default settings, the sensor pixel rate doubles when switching from preview (Context A) to full-resolution (Context B). Additionally, the number of pixels to be read per line nearly doubles. This naturally keeps the line rates roughly equal. The difference occurs due to border pixels: for SOC operation, there are always 8 border pixels regardless of context, thus the number of pixels in each line is not quite doubled.

Horizontal Blanking

Defined in terms of “sensor pixel clocks.” The sensor pixel clock rate doubles when switching from low-power readout mode (preview Context A) to full-power readout mode (full-resolution Context B). To maintain the same horizontal blanking time, the value for horizontal blanking must double. This is handled by the dual, context-switchable horizontal blanking registers.

Switching Modes

Initiate mode switches from preview (Context A) to snapshot (Context B) during vertical blanking; switching should be accompanied by a sensor restart. Be sure R200:0[15] is written as “1” when changing contexts.

Switching Frequency

The user can switch between sensor contexts as frequently as necessary (without affecting exposure) with the default values for horizontal blanking and vertical blanking (R5:0–R8:0). Usefully, constant switches can occur as often as once per frame.

Simple Snapshots

To take a snapshot, simply switch from Context A to Context B (with restart) for a few frames, then switch back again, capturing one of the Context B frames as the snapshot. Alternative methods are supported by an internal sequencer. These additional methods are particularly useful for taking flash snapshots.



Output Timing

Figure 10: Vertical Timing

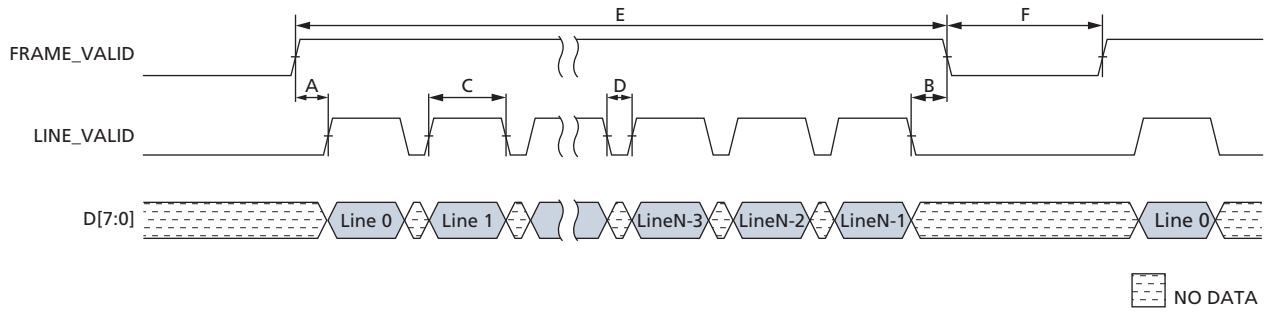
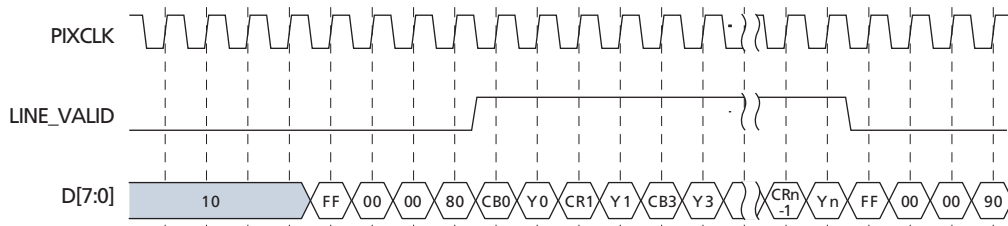

Figure 11: Horizontal Timing





Typical Resolutions, Modes and Timing

The parameters in Table 16 are illustrated in wave-form diagram Figure 10 on page 50. Table 20 provides values for these parameters in some common resolutions and operating modes.

Table 16: Blanking Definitions

DESIGNATION	DEFINITION
(A)	FRAME_VALID (rising edge) to LINE_VALID (rising edge) delay
(B)	LINE_VALID (falling edge) to FRAME_VALID (falling edge) delay
(C)	LINE_VALID (HIGH/valid) time
(D)	LINE_VALID (LOW/horizontal blanking) time
(E)	FRAME_VALID (HIGH/valid) time
(F)	FRAME_VALID (LOW/vertical blanking) time

Reset, Clocks, and Standby

Functional Operation

Power-up reset is asserted/de-asserted on the RESET# pin. It is active LOW. In this reset state, all control registers have the default values. All internal clocks are turned off except for the divided-by-2 clock to the sensor core.

Soft reset is asserted/de-asserted by the two-wire serial interface program. There are sensor hardmac soft resets and SOC soft resets. In soft reset mode, the two-wire serial interface and register ring bus are still running. All control registers are reset using default values. See R13:0.

Hard standby is asserted/de-asserted on the STANDBY pin. It is active HIGH. In this hard standby state, all internal clocks are turned off and analog block is in standby mode to save power consumption.

(Note: following the assertion of hard standby, at least 24 master clock cycles must be delivered to complete the transition to the hard standby state.)

Soft standby is asserted/de-asserted differently in the sensor page or colorpipe page. The sensor soft standby bit is in R13:0[2]. Colorpipe soft standby disables some of the SOC clocks, including the pixel clock. This bit is R179:1[0]. The colorpipe should be brought out of standby first via R179:1[0].

The colorpipe soft standby is provided to enable the user to turn off the colorpipe and the sensor independently.

By default, all outputs except SDATA are disabled during hard standby. This feature can be disabled by setting R179:1[1] = 0. Independent control of the outputs is available either via the OE# pin or R13:0[4]. All outputs are implemented using bidirectional buffers, thus should not be left tri-stated. In dual camera applications, ensure that one camera is driving the bus, or that the bus is pulled to VGNDQ or VDDQ, even during standby.



Electrical Specifications

Table 17: Electrical Characteristics and Operating Conditions
 $(T_A = \text{Ambient} = 25^\circ\text{C})$

PARAMETER	CONDITION	MIN	TYP	MAX	UNIT
I/O digital voltage (VDDQ)		1.7V		3.6V	V
Core digital voltage (VDD)		2.5V	2.8V	3.1V	V
Analog voltage (VAA)		2.5V	2.8V	3.1V	V
Pixel supply voltage (VAAPIX)		2.5V	2.8V	3.1V	V
Leakage current	STANDBY, No clocks			10	μA
Operating Temperature	Measured at junction	-30		+70	$^\circ\text{C}$

NOTE:

VDD, VAA, and VAAPIX must all be at the same potential to avoid excessive current draw. Care must be taken to avoid excessive noise injection in the analog supplies if all three supplies are tied together.

Table 18: I/O Parameters

PIN	PARAMETER	DEFINITIONS	CONDITION	MIN	TYP	MAX	UNIT
All Outputs		Load capacitance				30	pF
		Output pin slew	2.8V, 30pF load		0.72		V/ns
			2.8V, 5pF load		1.25		V/ns
			1.8V, 30pF load		0.34		V/ns
			1.8V, 5pF load		0.51		V/ns
	VOH	Output high voltage					V
	VOL	Output low voltage					V
	IOH	Output high current	VDDQ = 2.8V, VOH = 2.4V	16		26.5	mA
			VDDQ = 1.8V, VOH = 1.4V	8		15	mA
		IOL	Output low current	VDDQ = 2.8V, VOL = 0.4V	15.9		21.3
VDDQ = 1.8V, VOL = 0.4V				10.1		16.2	mA
IOZ	Tri-state output leakage current						
All Inputs	VIH	Input high voltage	VDDQ = 2.8V	1.48			V
			VDDQ = 1.8V	0.94			V
	VIL	Input low voltage	VDDQ = 2.8V			1.43	V
			VDDQ = 1.8V			0.84	V
	IIN	Input leakage current		-2 μ			2 μA
PIN CAP	Pin input capacitance			3.5		pF	
CLKIN	Freq	Master clock frequency	Absolute minimum	2			MHz
			SXGA @ 15 fps	48		54	MHz

Power Consumption
Table 19: Power Consumption at 2.8V

MODE	SENSOR/mW	IMAGE FLOW PROC/mW	I/OS (10pF)/mW	TOTAL M/mW
SXGA at 15 fps	90	71	9	170
QSXGA at 30 fps	50	36	4	90
QSXGA at 15 fps	50	18	2	70
QVGA at 30 fps	50	32	1	83



I/O Timing

By default, the MT9M111 launches pixel data, FRAME_VALID, and LINE_VALID synchronously with the falling edge of PIXCLK. The expectation is that the user captures data, FRAME_VALID, and LINE_VALID

using the rising edge of PIXCLK. The timings in Figure 12 assume that the sense of PIXCLK is inverted from the default. This is achieved by setting R58:1[9] and R155:[9] = 1.

Figure 12: I/O Timing Diagram

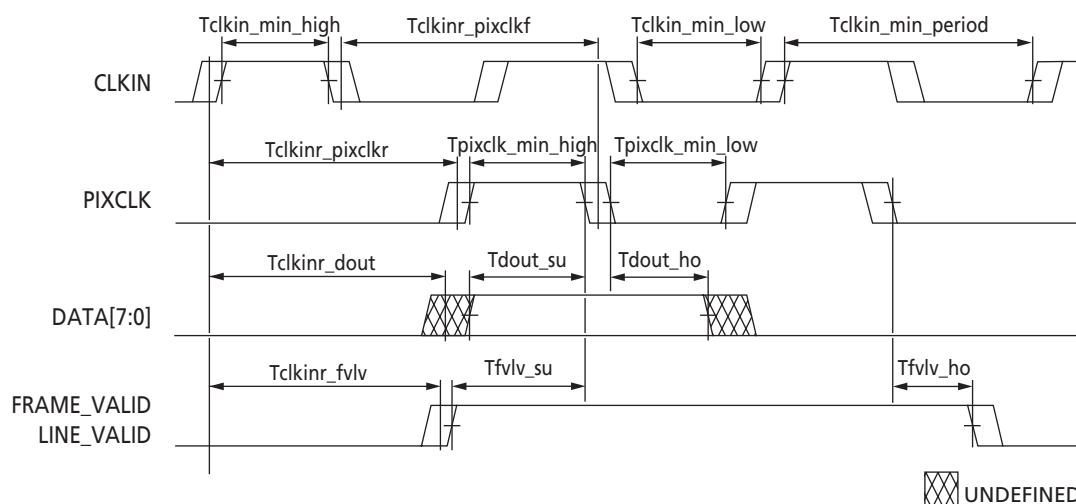

Table 20: I/O Timing Table

SIGNAL	PARAMETER	CONDITIONS	SLOW		FAST		UNIT
			MIN	MAX	MIN	MAX	
CLKIN	Tclk_in_min_high		7.4		7.4		ns
	Tclk_in_min_low		7.4		7.4		ns
	Tclk_in_min_period		18.5		18.5		ns
PIXCLK	Tclk_in_pixclkr		16.5	16.9	7.7	7.9	ns
	Tclk_in_pixclkf		17.5	17.6	7.9	8.0	ns
	Tpixclk_min_low	50:50, 54 MHz CLKIN	8.2		9.0		ns
	Tpixclk_min_high	50:50, 54 MHz CLKIN	9.9		9.3		ns
DATA[7:0]	Tclk_in_dout		15.7	18.6	7.6	8.6	ns
	Tdout_su	50:50, 54 MHz CLKIN	8.2		8.6		ns
	Tdout_ho	50:50, 54 MHz CLKIN	7.4		8.9		ns
FRAME_VALID/LINE_VALID	Tclk_in_fvlv		18.0	21.0	8.8	9.9	ns
	Tfvlv_su	50:50, 54 MHz CLKIN	5.8		7.3		ns
	Tfvlv_ho	50:50, 54 MHz CLKIN	9.7		10.1		ns

Figure 13: Spectral Response Chart (Preliminary)

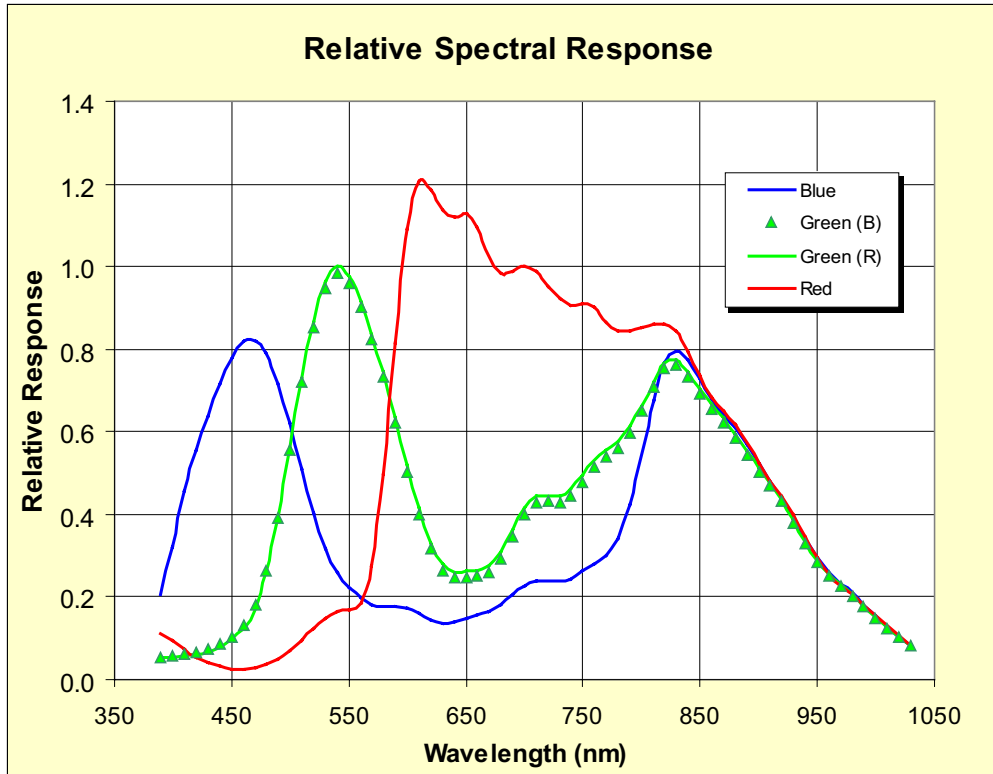
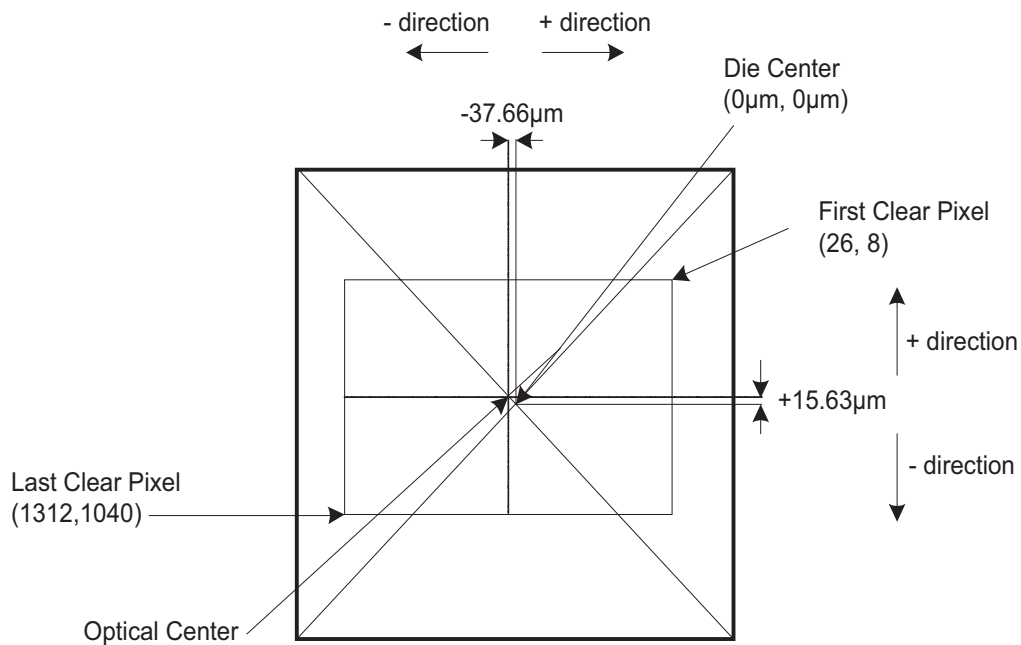

Figure 14: Optical Center Diagram



NOTE:
Figure not to scale.

APPENDIX A

Serial Bus Description

Registers are written to and read from the MT9M111 through the two-wire serial interface bus. The sensor is a serial interface slave and is controlled by the serial clock (SCLK). SCLK is driven by the serial interface master. Data is transferred into and out of the MT9M111 through the serial data (SDATA) line. The SDATA line is pulled up to 2.8V off-chip by a 1.5K Ω resistor. Either the slave or the master device can pull the SDATA line down—the two-wire serial interface protocol determines which device is allowed to pull the SDATA line down at any given time.

Protocol

The two-wire serial interface defines several different transmission codes, as follows:

- a start bit
- the slave device 8-bit address. The SADDR pin is used to select between two different addresses in case of conflict with another device. If SADDR is LOW, the slave address is 0x90; if SADDR is HIGH, the slave address is 0xBA.
- an acknowledge or a no-acknowledge bit
- an 8-bit message
- a stop bit.

Sequence

A typical read or write sequence begins with the master sending a start bit. After the start bit, the master sends the 8-bit slave device address. The last bit of the address determines if the request is a read or a write, where a “0” indicates a write and a “1” indicates a read. The slave device acknowledges its address by sending an acknowledge bit back to the master.

If the request was a write, the master transfers the 8-bit register address to which a write should take place. The slave sends an acknowledge bit to indicate that the register address has been received. The master then transfers the data, 8 bits at a time, with the slave sending an acknowledge bit after each 8 bits.

The MT9M111 uses 16-bit data for its internal registers, thus requiring two 8-bit transfers to write to one register. After 16 bits are transferred, the register address is automatically incremented, so that the next 16 bits are written to the next register address. The master stops writing by sending a start or stop bit.

A typical read sequence is executed as follows. The master sends the write-mode slave address and 8-bit register address, just as in the write request. The master then sends a start bit and the read-mode slave

address. The master clocks out the register data, 8 bits at a time, and sends an acknowledge bit after each 8-bit transfer. The register address is auto-incremented after every 16 bits is transferred. The data transfer is stopped when the master sends a no-acknowledge bit.

Bus Idle State

The bus is idle when both the data and clock lines are HIGH. Control of the bus is initiated with a start bit, and the bus is released with a stop bit. Only the master can generate the start and stop bits.

Start Bit

The start bit is defined as a HIGH-to-LOW transition of the data line while the clock line is HIGH.

Stop Bit

The stop bit is defined as a LOW-to-HIGH transition of the data line while the clock line is HIGH.

Slave Address

The 8-bit address of a two-wire serial interface device consists of seven bits of address and 1 bit of direction. A “0” in the least significant bit (LSB) of the address indicates write mode, and a “1” indicates read mode. The write address of the sensor is 0xBA; the read address is 0xBB. This applies only when the SADDR is set HIGH.

Data Bit Transfer

One data bit is transferred during each clock pulse. The serial interface clock pulse is provided by the master. The data must be stable during the HIGH period of the two-wire serial interface clock—it can only change when the serial clock is LOW. Data is transferred 8 bits at a time, followed by an acknowledge bit.

Acknowledge Bit

The master generates the acknowledge clock pulse. The transmitter (which is the master when writing, or the slave when reading) releases the data line, and the receiver signals an acknowledge bit by pulling the data line LOW during the acknowledge clock pulse.

No-Acknowledge Bit

The no-acknowledge bit is generated when the data line is not pulled down by the receiver during the acknowledge clock pulse. A no-acknowledge bit is used to terminate a read sequence.

Two-Wire Serial Interface Sample Write and Read Sequences (SADDR = 1)

16-Bit Write Sequence

A typical write sequence for writing 16 bits to a register is shown in Figure 15. A start bit sent by the master starts the sequence, followed by the write address. The image sensor sends an acknowledge bit and

expects the register address to come first, followed by the 16-bit data. After each 8-bit transfer, the image sensor sends an acknowledge bit. All 16 bits must be written before the register is updated. After 16 bits are transferred, the register address is automatically incremented so that the next 16 bits are written to the next register. The master stops writing by sending a start or stop bit.

Figure 15: Write Timing to R0x09:0—Value 0x0284

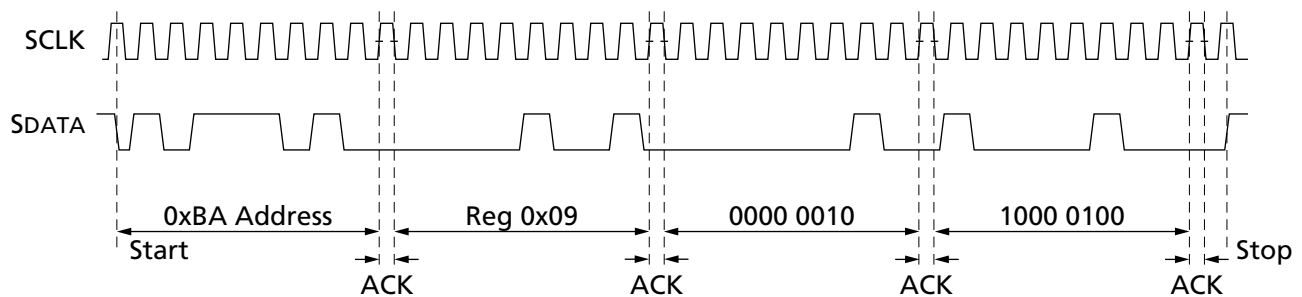

16-Bit Read Sequence

A typical read sequence is shown in Figure 16. The master writes the register address, as in a write sequence. Then a start bit and the read address specify that a read is about to occur from the register. The master then clocks out the register data, 8 bits at a

time. The master sends an acknowledge bit after each 8-bit transfer. The register address should be incremented after every 16 bits is transferred. The data transfer is stopped when the master sends a no-acknowledge bit.

Figure 16: Read Timing from R0x09:0; Returned Value 0x0284

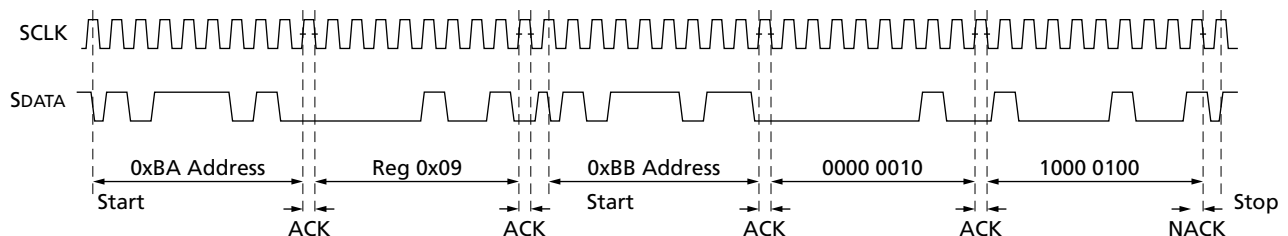



8-Bit Write Sequence

To be able to write one byte at a time to the register, a special register address is added. The 8-bit write is started by writing the upper 8 bits to the desired register, then writing the lower 8 bits to the special register

address (R0xF1:0). The register is not updated until all 16 bits have been written. It is not possible to update just half of a register. Figure 17 shows a typical sequence for an 8-bit write. The second byte is written to the special register (R0xF1:0).

Figure 17: Write Timing to R0x09:0—Value 0x0284

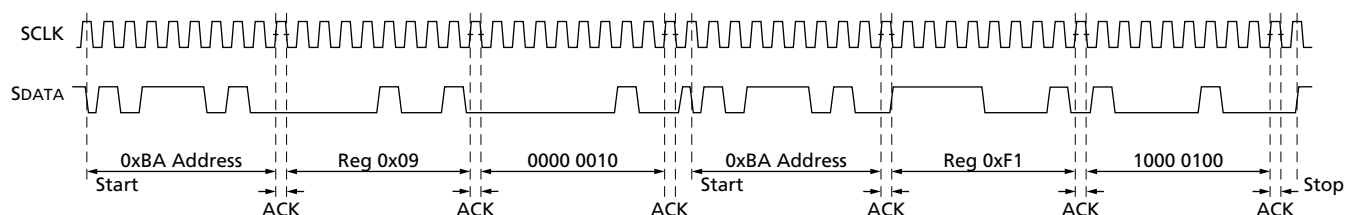

8-Bit Read Sequence

To read one byte at a time, the same special register address is used for the lower byte. The upper 8 bits are read from the desired register. By following this with a

read from the special register (R0xF1:0), the lower 8 bits are accessed (Figure 18). The master sets the no-acknowledge bits shown.

Figure 18: Read Timing from R0x09:0; Returned Value 0x0284

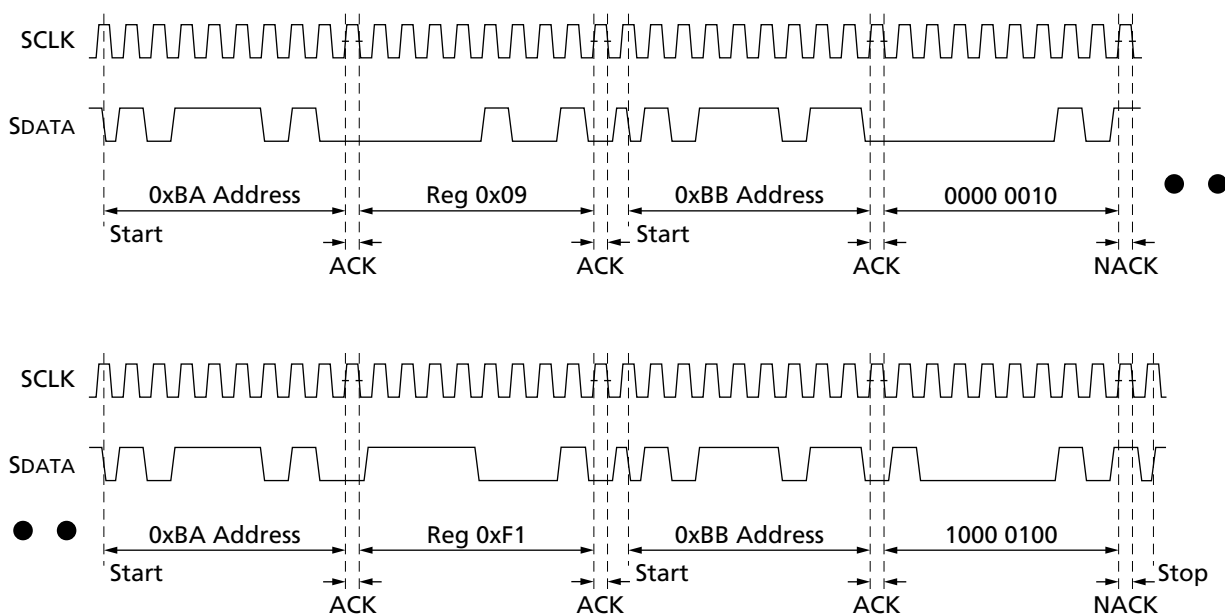

Two-Wire Serial Bus Timing

The two-wire serial bus operation requires certain minimum master clock cycles between transitions. These are specified in the following diagrams in master clock cycles.



Figure 19: Serial Host Interface: Start Condition Timing

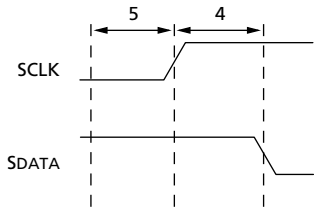
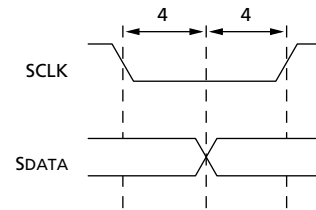

Figure 21: Serial Host Interface Write



NOTE:

SDATA is driven by an off-chip transmitter.

Figure 20: Serial Host Interface: Stop Condition Timing

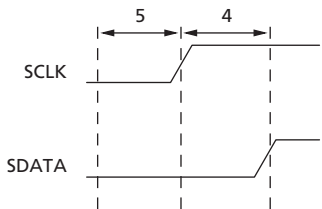
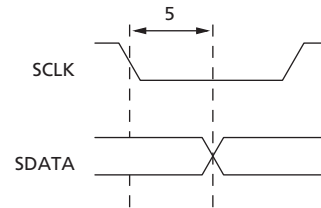

Figure 22: Serial Host Interface Read



NOTE:

SDATA is pulled LOW by the sensor, or allowed to be pulled HIGH by an off-chip pull-up resistor.

NOTE:

All timing in master clock cycle units.

Figure 23: Acknowledge Signal Timing After an 8-Bit Write to Sensor

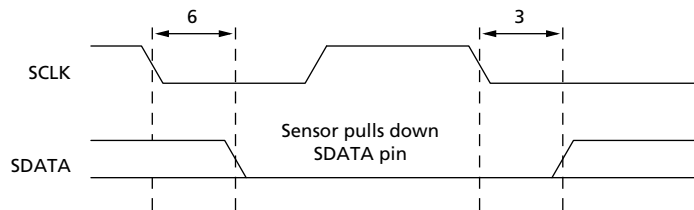
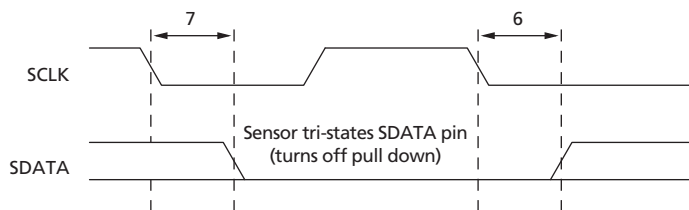

Figure 24: Acknowledge Signal Timing After an 8-Bit Read from Sensor



NOTE:

After a read, the master receiver must pull down SDATA to acknowledge receipt of data bits. When the read sequence is complete, the master generates a no-acknowledge bit by leaving SDATA to float HIGH. On the following cycle, either a start or stop bit can be used.



Figure 25: 44-Ball iCSP Package

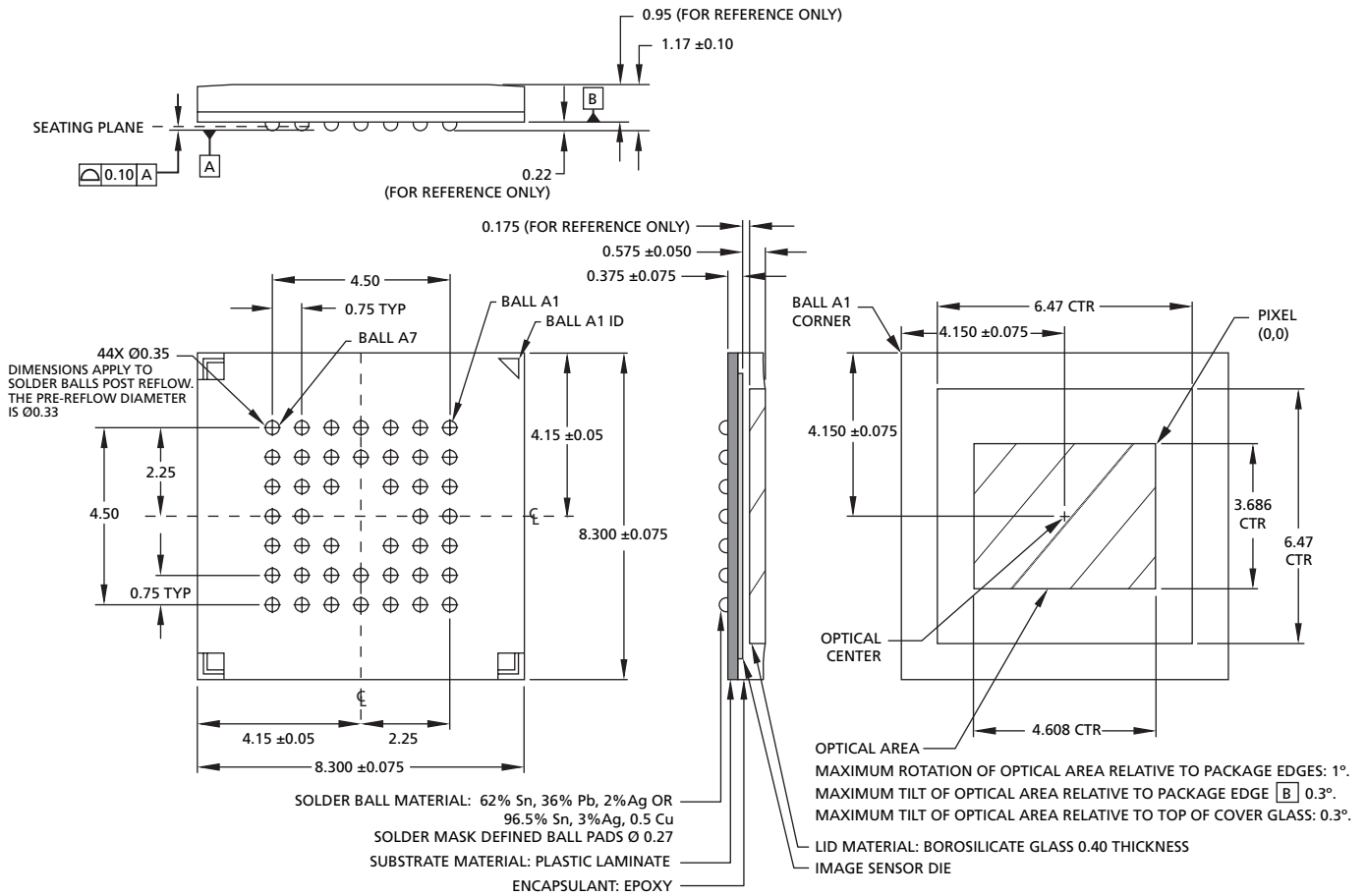

NOTE:

Dimensions are in millimeters MIN/MAX or typical where noted.

Data Sheet Designation: Preliminary

This data sheet contains initial characterization limits that are subject to change upon full characterization of production devices.



8000 S. Federal Way, P.O. Box 6, Boise, ID 83707-0006, Tel: 208-368-3900

E-mail: prodmktg@micron.com, Internet: <http://www.micron.com>, Customer Comment Line: 800-932-4992

Micron, the M logo, and the Micron logo are trademarks of Micron Technology, Inc.

All other trademarks are the property of their respective owners.



Revision History

Rev. C, Preliminary 10/04

- Added STANDBY to Figure 3, Typical Configuration (Connection), on page 9.

Rev. B, Preliminary 7/04

- Updated package diagram.
 - Clarified low-power readout mode.

Rev. A, Preliminary 5/04

- Initial release.