



# AKD4528

## Evaluation board AK4528 Rev.C

GENERAL DESCRIPTION

The AKD4528 is an evaluation board for the AK4528, the 24Bit A/D & D/A converter. The AKD4528 can evaluate A/D converter and D/A converter separately in addition to Loopback mode (A/D→D/A). The AKD4528 also has the digital audio interface and can achieve the interface with digital audio systems via opt-connector.

■ **Ordering guide**

AKD4528 --- Evaluation board for AK4528  
 (Cable for connecting with printer port of IBM-AT compatible PC and control software are packed with this.)

FUNCTION

- Digital interface**  
 - DIT (AK4353), DIR (AK4112A) with optical output/input.
- 10pin header for serial control interface**

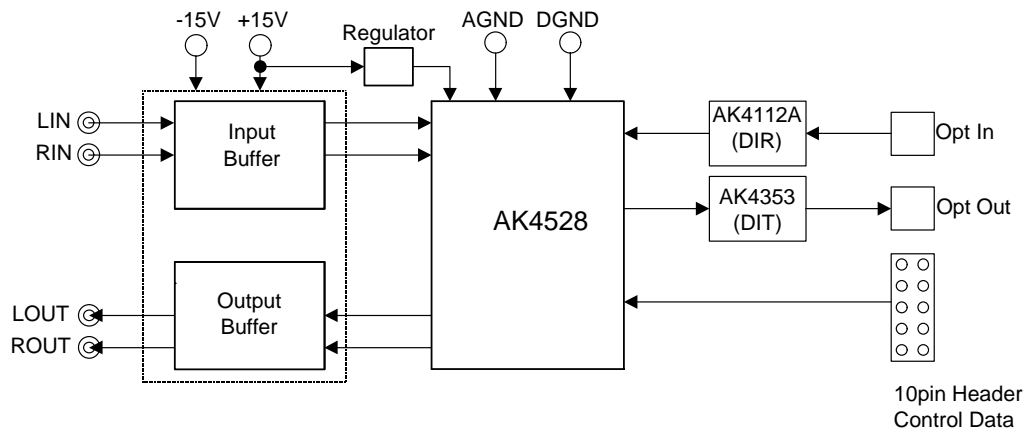

Figure 1. AKD4528 Block Diagram

\* Circuit diagram and PCB layout are attached at the end of this manual.

**1. Analog Input Buffer Circuit**

The ADC inputs are full differential and the input resistance is 27kΩ (typ. @fs=44.1kHz). The input signal range scales with the VREF voltage and nominally 0.56 x VREF Vpp. It is recommended that the input DC bias voltage is 2.9V(The bias is a voltage divided by resistors (3.3k and 4.7k) from VA in figure 2. The ADC output data format is 2's complement. The output code is 7FFFFFFH(@24bit) for input above a positive full scale and 800000H(@24bit) for input below a negative full scale. The ideal code is 000000H(@24bit) with no input signal. The DC offset including ADC own DC offset removed by the internal HPF (fc=0.9Hz@fs=44.1kHz).

The AK4528 samples the analog inputs at 64fs. The digital filter rejects noise above the stopband except for multiples of 64fs. A simple RC filter may be used to attenuate any noise around 64fs though most audio signals do not have significant energy at 64fs. Figure 2 is an example of differential input circuit.

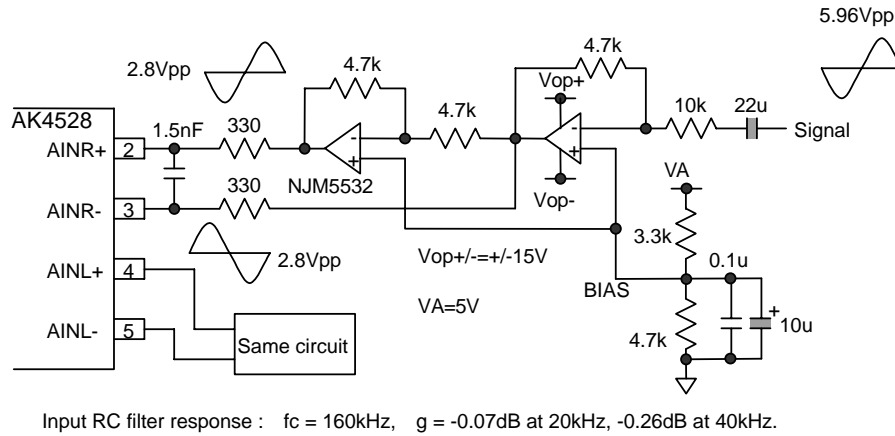

Figure 2. Differential Input Buffer Example

**2. Analog Output Buffer Circuit**

The 2nd-order LPF (fc=93.2kHz, Q=0.712) which adds differential output of AK4528 is implemented on the board. When the further attenuation of the out-band noise is needed, some additional LPF is required. NJM5532D is used for op-amp. Analog signal is output through BNC connectors (AOUTL, AOUTR) on board, and the output level of AK4528 is about 5.4Vp-p.

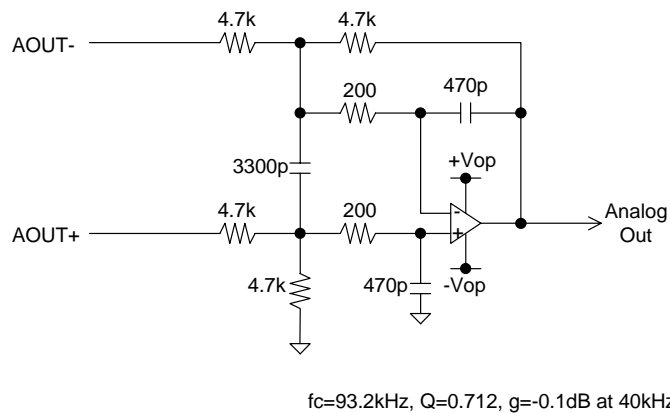

Figure 3. External 2nd order LPF Example (using dual supply op-amp)

## 1. Evaluation Board Manual

### ■ Operation sequence

- 1) Set up the power supply line
  - [+15V] (Orange) = +15V
  - [-15V] (Green) = -15V
  - [AGND] (Black) = 0V
  - [DGND] (Black) = 0V

Note: Power should be supplied after jumpers are set-ups properly.  
Each supply line should be distributed from the power supply unit.

- 2) Set up the evaluation modes, jumper pins and DIPswitch. (See the followings.)

- 3) Power on  
The AK4528 should be reset once bringing SW3 (PDN) "L" upon power-up.

### ■ Evaluation modes

#### **Applicable evaluation modes**

- (1) Loopback mode (default)
- (2) Evaluation of ADC
- (3) Evaluation of DAC

- (1) Loopback mode (default)  
Clock mode of the AK4112A should be set to X'tal mode.
- (2) Evaluation of ADC  
TOTX176 is used for digital output. Clock mode of the AK4112A should be set to X'tal mode.
- (3) Evaluation of DAC  
TORX176 or COAX is used for digital input. Clock mode of the AK4112A should be set to PLL mode.

### ■ SW2 set-up (AK4112A set up. See datasheet of AK4112A.)

#### 1. DIF2, DIF1 and DIF0 of SW2 set -up.

Set the mode of AK4112A

DIF2	DIF1	DIF0	ADC format at Loopback	Input format of DAC	LRCK	BICK
0	0	0	24bit, Left justified	16bit, Right justified	H/L	64fs
0	0	1	24bit, Left justified	18bit, Right justified	H/L	64fs
0	1	0	24bit, Left justified	20bit, Right justified	H/L	64fs
0	1	1	24bit, Left justified	24bit, Right justified	H/L	64fs
1	0	0	24bit, Left justified	24bit, Left justified	H/L	64fs
1	0	1	24bit, I <sup>2</sup> S	24bit, I <sup>2</sup> S	L/H	64fs

default

#### 2. CM1 and CM0 set-up

Clock source select of AK4112A

CM1	CM0	PLL	X'tal	Clock source	Input data of DAC
0	0	ON	OFF	PLL	optical
0	1	OFF	ON	X'tal	output of ADC

default

ON: Oscillation (Power-up), OFF: STOP (Power-down)

#### 3. OCKS1 and OCKS0 set-up

MCLK output of AK4112A

OCKS1	OCKS0	MCKO1	fs (kHz)
0	0	256fs	32, 44.1, 48, 96
0	1	256fs	32, 44.1, 48, 96
1	0	512fs	32, 44.1, 48

default

■ **SW4 set-up**

Set the mode of AK4528.

[SW4]: AK4528 set-up

No.	Pin	OFF	ON
1	CKS0	Master clock mode(default : X'tal mode) (See datasheet of AK4528.)	
2	CKS1		
3	DIF	MSB justified	I2S(default)
4	DFS	normal speed(default)	double speed
5	DEM0	De-emphasis(default : OFF) (see datasheet of AK4528)	
6	DEM1		
7	P/S	serial mode	parallel mode (default)

Table 1. SW4 set up

■ **Jumper set-up**

JP1 (OPT/RX): optical connector or BNC

OPT (default) : Biphase signal is supplied to AK4112A by optical connector.

RX : Biphase signal is supplied to AK4112A by BNC connector.

■ **The indication content for LED.**

[LE1] (ERF) : AK4112A unlock and parity error output.

[LE2] (FS96) : AK4112A 96kHz sampling detect.

[LE3] (AUTO) : AK4112A AC-3/MPEG detects.

[LE4] (V) : Validity.

■ **The function of the toggle SW.**

[SW3] : Resets the AK4528, AK4112A and AK4353. Keep “H” during normal operation.

■ **Serial control mode**

The AK4528 can be controlled via the printer port (parallel port) of IBM-AT compatible PC. Connect PORT2 (CR-I/F) with PC by 10-wire flat cable packed with the AKD4528.

Take care of the direction of connector. There is a mark at pin#1.  
The pin layout of PORT1 is as Figure 4.

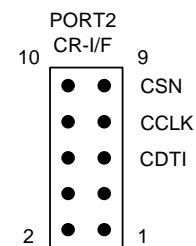

Figure 4. PORT2 pin layout

## 2. Control Software Manual

### ■ Set-up of evaluation board and control software

1. Set up the AKD4528 according to previous term.
2. Connect IBM-AT compatible PC with AKD4528 by 10-line type flat cable (packed with AKD4528). Take care of the direction of 10pin header. (This control software does not operate on Windows NT, therefore please operate it on Windows95/98.)
3. Insert the floppy disk labeled “AKD4528 Control Program ver 1.0” into the floppy-disk drive.
4. Access the floppy-disk drive and double-click the icon of “akd4528.exe” to set up the control program.
5. Then please evaluate according to the follows.

### ■ Explanation of each buttons

1. [Port Setup]: set up the printer port.
2. [Write default]: initialize the register of AK4528.
3. [Function1]: set up the dialog, which can be written by keyboard operation.
4. [Function2]: set up the dialog, which can be written by keyboard operation.
5. [Write]: set up the dialog corresponding to each register, which can be written by mouse operation.

### ■ Explanation of each dialog

1. [Function1 Dialog]: Dialog to write data by keyboard operation

Address Box: Input registers address in 2 figures of hexadecimal.  
Data Box: Input registers data in 2 figures of hexadecimal.

If you want to write the input data to AK4528, click “OK” button. If not, click “Cancel” button.

## 2. [Function2 Dialog]: Dialog to evaluate DATT

This dialog corresponds to only addr=08H and 09H

Address Box: Input registers address in 2 figures of hexadecimal.  
 Start Data Box: Input starts data in 2 figures of hexadecimal.  
 End Data Box: Input end data in 2 figures of hexadecimal.  
 Interval Box: Data is written to AK4528 by this interval.  
 Step Box: Data changes by this step.  
 Mode Select Box:

If you check this check box, data reaches end data, and returns to start data.

[Example] Start Data = 00, End Data = 09  
 Data flow: 00 01 02 03 04 05 06 07 08 09 09 08 07 06 05 04 03 02 01 00

If you do not check this check box, data reaches end data, but does not return to start data.

[Example] Start Data = 00, End Data = 09  
 Data flow: 00 01 02 03 04 05 06 07 08 09

If you want to write the input data to AK4528, click “OK” button. If not, click “Cancel” button.

## 3. [Write Dialog]: Dialog to write data by mouse operation

There are dialogs corresponding to each register.

Click the “Write” button corresponding to each register to set up the dialog. If you check the check box, data becomes “H” or “1”. If not, “L” or “0”.

If you want to write the input data to AK4528, click “OK” button. If not, click “Cancel” button.

### ■ Operation flow

Keep the following flow surely.

1. Set up the control program according to explanation above.
2. Click “Port Setup” button.
3. Click “Write default” button.
4. Then set up the dialog and input data.

### ■ Indication of data

Input data is indicated on the register map. Red letter indicates “H” or “1” and blue one indicates “L” or “0”. Blank is the part that is not defined in the datasheet.

### ■ Attention on the operation

If you set up Function1 or Function2 dialog, input data to all boxes. Attention dialog is indicated if you input data or address that is not specified in the datasheet or you click “OK” button before you input data. In that case set up the dialog and input data once more again. This operation does not need if you click “Cancel” button or check the check box.

**AK4353 Control Program operation manual**

1. Connect IBM-AT compatible PC with Eva-board by 10-line type flat cable (packed with Eva-board).  
Take care of the direction of 10pin Header (Refer to manual of Eva-board).
2. Start up "WINDOWS 95" or "WINDOWS 98".
3. Insert the floppy disk packed with Eva-board into the floppy-disk drive.
4. Set up "MS-DOS" from start menu.
5. Change directory to the floppy-disk drive (ex.a:) at MS-DOS prompt.
6. Type "4353".
7. Then follow the displayed comment (See the following).

===== <<Operating flow>> =====  
Write data/ Display register map/ Reset etc. → loop  
=====



At first the following message is displayed:

```
***** AK4353 Control Program ver 3.0 , '00/2 *****
copyright(c) 2000, Asahi Kasei Microsystems co.,ltd.
All rights reserved.
```

Then the following default register map is displayed (Loop starts from here):

```
3-wire Serial control mode CAD1-0=11 -----
ADDR = 00 : 0B <Control 1> ( 0 0 0 0 DIF2 DIF1 DIF0 RSTN )
ADDR = 01 : 01 <Control 2> ( 0 0 DFS1 DFS0 CKS2 CKS1 CKS0 RSTN )
ADDR = 02 : 94 <Control 3> ( PL3 PL2 PL1 PL0 DEM1 DEM0 ATC SMUTE )
ADDR = 03 : FF <Lch ATT> ( ATT7 ATT6 ATT5 ATT4 ATT3 ATT2 ATT1 ATT0 )
ADDR = 04 : FF <Rch ATT> ( ATT7 ATT6 ATT5 ATT4 ATT3 ATT2 ATT1 ATT0 )
ADDR = 05 : 00 <TX> ( 0 0 0 0 0 0 0 V TXE )
ADDR = 06 : 00 <Ch Status 1>( 0 CS29 CS28 CS24 CS3 CS2 CS2 CS1 )
ADDR = 07 : 04 <Ch Status 2>( CS15 CS14 CS13 CS12 CS11 CS10 CS9 CS8 )

Input l(Write), R(Reset), T(Table), I(Increment), D(Decrement) or S(Stop) :
```

1) If you input "l", you can write data to AK4353.

```
You can write data to AK4353
Input Register Address ( 2 figure, hex ) (00-07) =
```

Input register address in 2 figures of hexadecimal.

Then current data of this address is displayed:

```
ADDR = 00 : 0B <Control 1> ( 0 0 0 0 DIF2 DIF1 DIF0 RSTN )
                                0 0 0 0 0 1 0 1 1
Input Register Data ( 2 figure, hex ) (00-FF) =
```

You can write control data to this address. Input control data in 2 figures of hexadecimal.

Refer to datasheet of AK4353.

Then the data written to this address is displayed:

```
ADDR = 00 : 09 <Control 1> ( 0 0 0 0 DIF2 DIF1 DIF0 RSTN )
                                0 0 0 0 0 1 0 0 1
```

- 2) If you input "R" or "r", this program writes default data to all register addresses.
- 3) If you input "T" or "t", current register map is displayed.
- 4) If you input "I" or "i", this program increment data of current address by 1 (only for addr=03H or 04H). You can increment ATT value by 1step.
- 5) If you input "D" or "d", this program decrement data of current address by 1 (only for addr=03H or 04H). You can decrement ATT value by 1step.
- 6) If you input "S" or "s", this program is terminated.

AK4528 Measurement Result

## Conditions:

Measurement unit: Audio Precision System Two Cascade

MCLK: 256fs

BICK: 64fs

LRCK: 44.1kHz(DIR or DIT), or 96kHz(DIR or DIT)

Power supply: VA=VD=VT=5.0V

Interface: DIT or DIR

Temperature: Room Temp.

## 1. ADC

## 1-1. fs = 44.1kHz

Parameter	Input signal	BW, filter	Results		unit
			Lch	Rch	
S/(N+D)	1kHz, -0.5dB	20kHz	98.4	98.2	dB
Dynamic range	1kHz, -60dB	20kHz	102.6	102.6	dB
		20kHz, A-weighted	107.4	107.5	dB
S/N	off	20kHz	102.8	102.8	dB
		20kHz, A-weighted	107.5	107.5	dB

## 1-2. fs=96kHz

Parameter	Input signal	BW, filter	Results		unit
			Lch	Rch	
S/(N+D)	1kHz, -0.5dB	fs/2	91.4	92.8	dB
Dynamic range	1kHz, -60dB	fs/2	99.8	99.9	dB
		fs/2, A-weighted	108.3	108.5	dB
S/N	off	fs/2	100.0	100.8	dB
		fs/2, A-weighted	108.9	109.0	dB

\*Audio Precision does not support 40kHzLPF

## DAC

## 2-1. fs=44.1kHz

Parameter	Input signal	BW, filter	Results		unit
			Lch	Rch	
S/(D+N)	1kHz, 0dBFS	20kHz	93.7	94.5	dB
Dynamic range	1kHz, -60dBFS	20kHz	108.0	108.0	dB
		22kHz, A-weighted	110.7	110.6	dB
S/N	"0" data	20kHz	108.2	108.0	dB
		22kHz, A-weighted	110.9	110.7	dB

## 2-2. fs=96kHz

Parameter	Input signal	BW, filter	Results		unit
			Lch	Rch	
S/(N+D)	1kHz, 0dBFS	40kHz	91.2	91.8	dB
Dynamic range	1kHz, -60dBFS	40kHz	104.8	104.9	dB
		80kHz, A-weighted	110.0	110.0	dB
S/N	"0" data	40kHz	104.9	104.8	dB
		80kHz, A-weighted	110.2	109.9	dB

(fs=44.1kHz)

1. ADC

AKM

AK4528 ADC FFT (Input Level=-0.5dBFS, fin=1kHz)

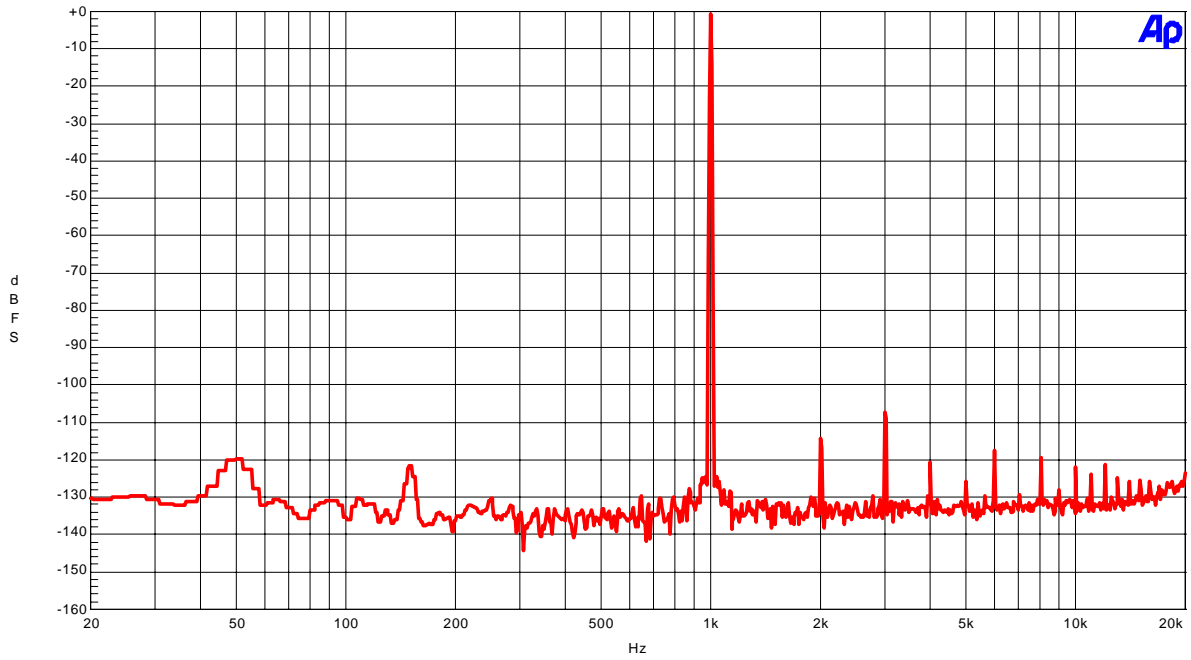

AKM

FFT (Input Level = -0.5dBFS, fin=1kHz)  
AK4528 ADC FFT (Input Level=-60dBFS, fin=1kHz)

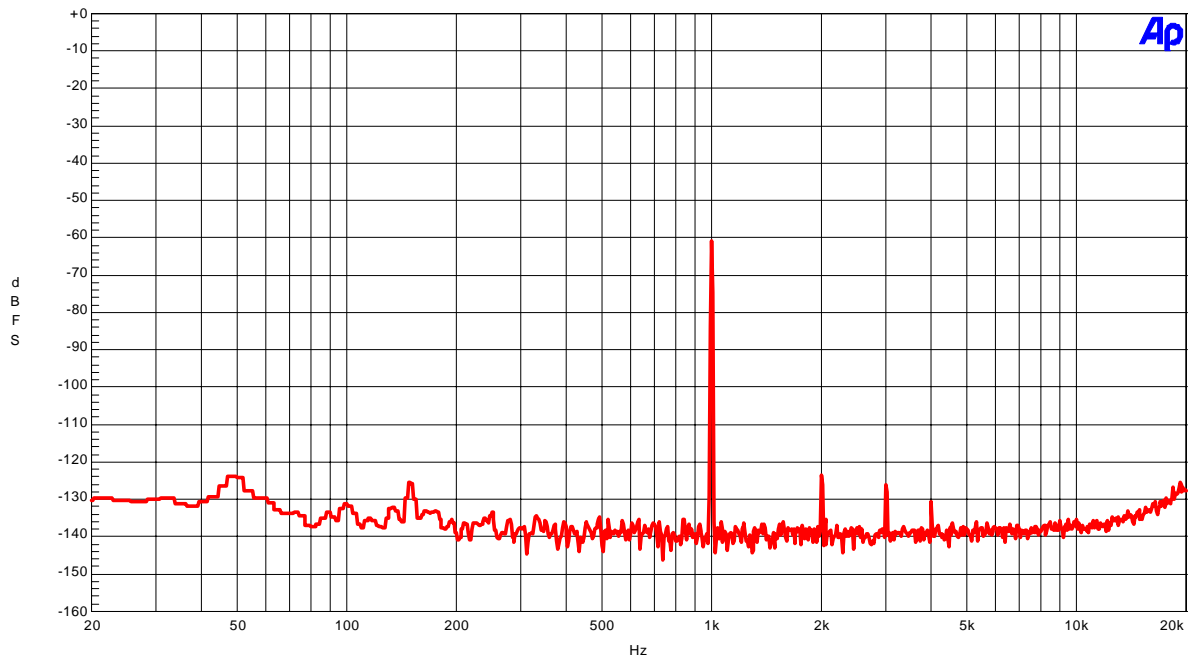

FFT (Input Level = -60dBFS, fin=1kHz)

(fs=44.1kHz)

AKM

AK4528 ADC FFT (noise floor)

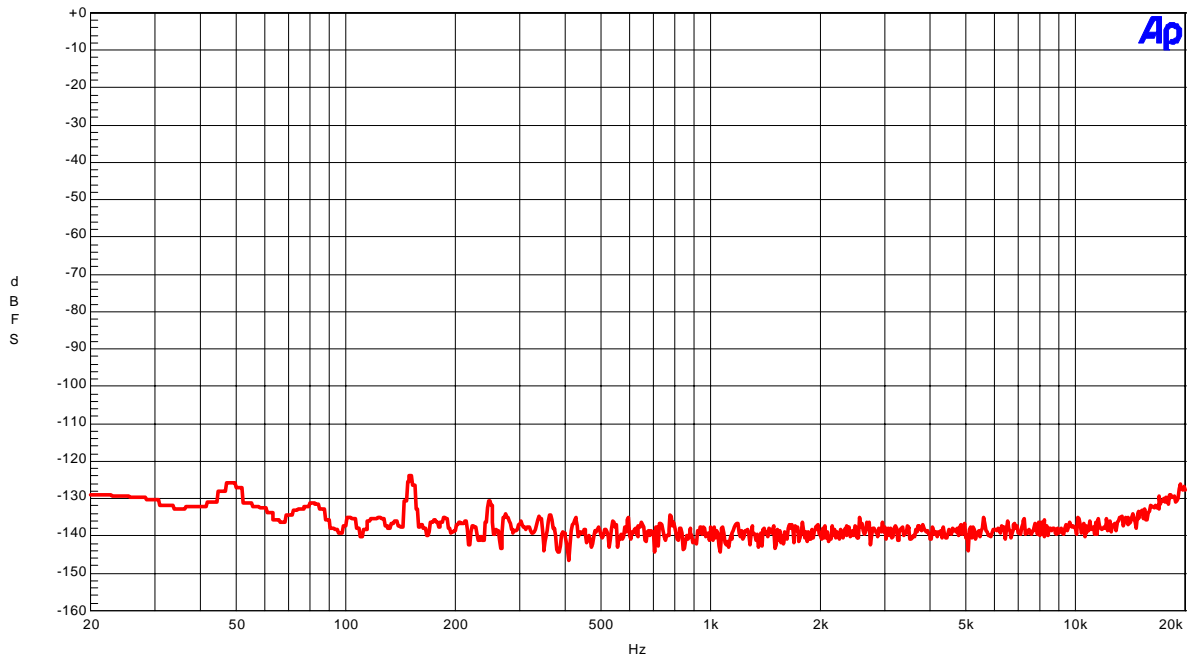

FFT (noise floor)

(fs=44.1kHz)

AKM

AK4528 ADC THD + N vs Amplitude(fin=1kHz)

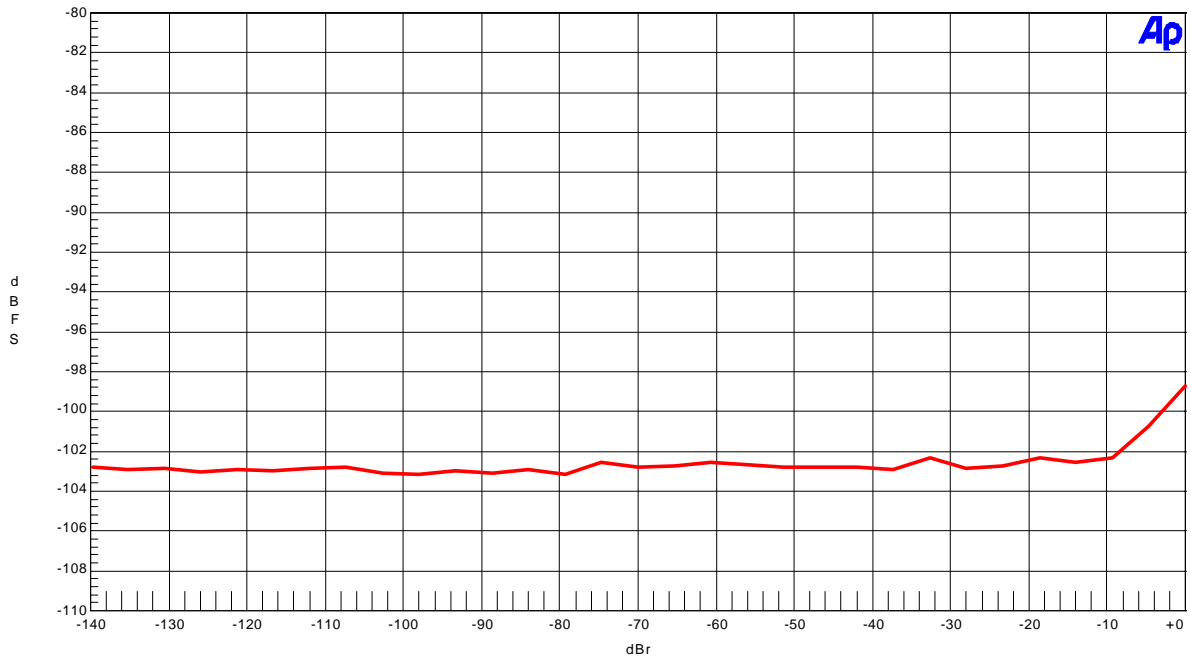

THD + N vs Amplitude (fin=1kHz)

AKM

AK4528 ADC THD + N vs Input Frequency(Input Level=0dBFS)

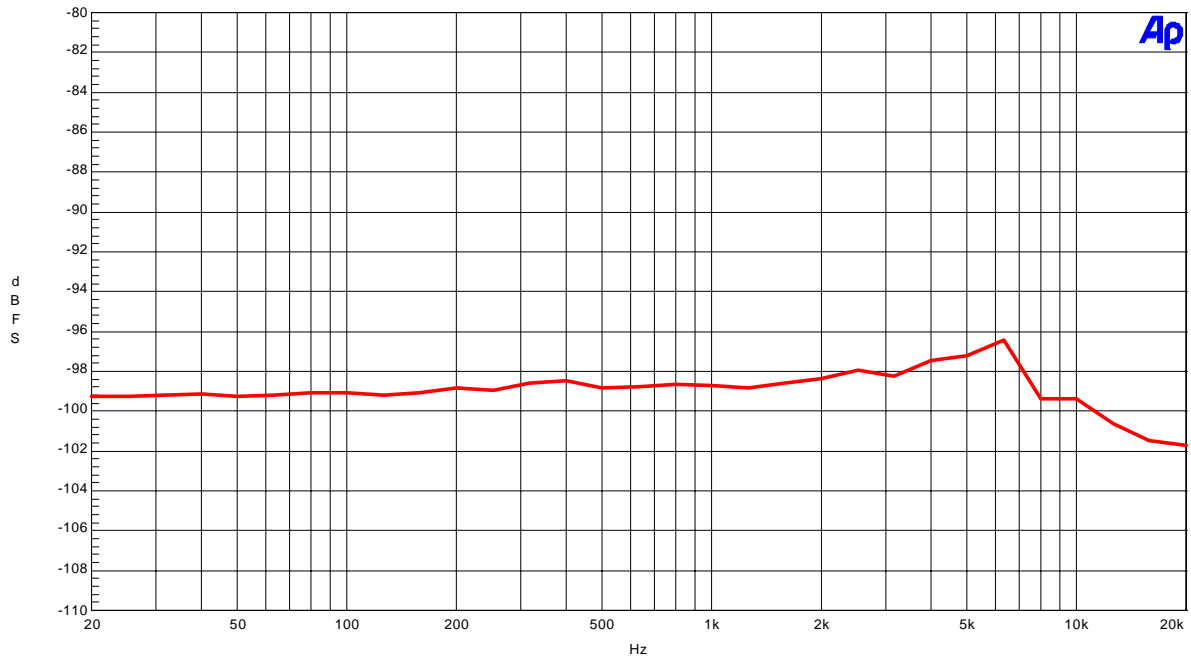

THD + N vs Input Frequency (Input Level = -0.5dBFS)

(fs=44.1kHz)

AKM

AK4528 ADC Linearity

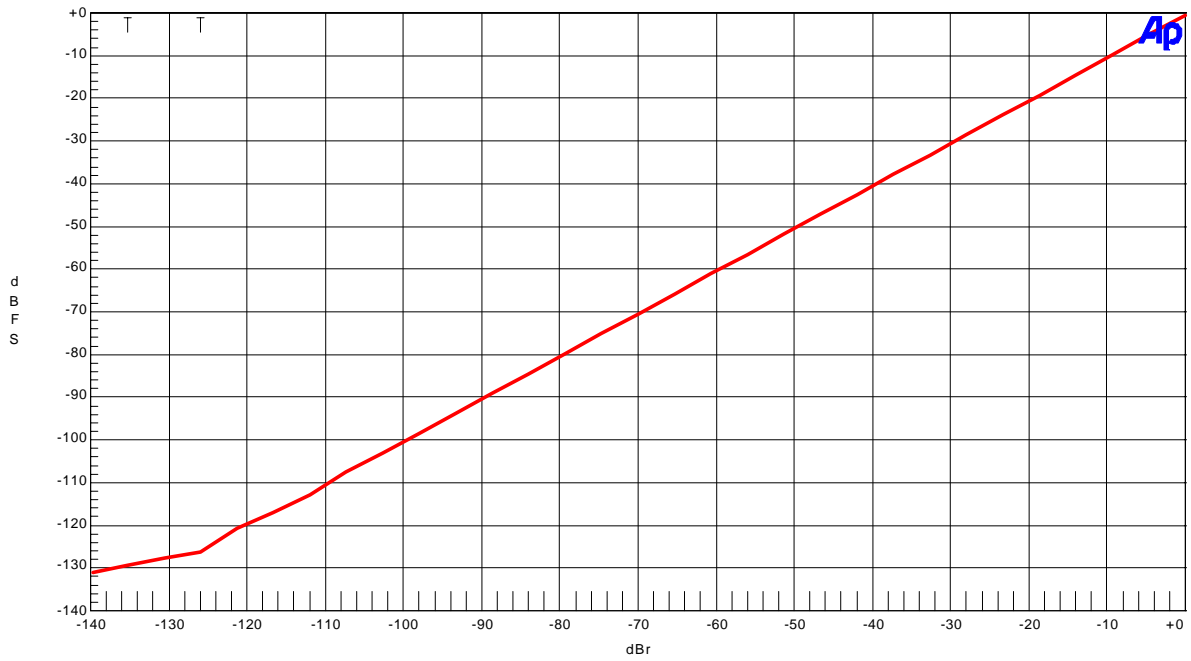

Linearity (fin=1kHz)  
AK4528 ADC Crosstalk

AKM

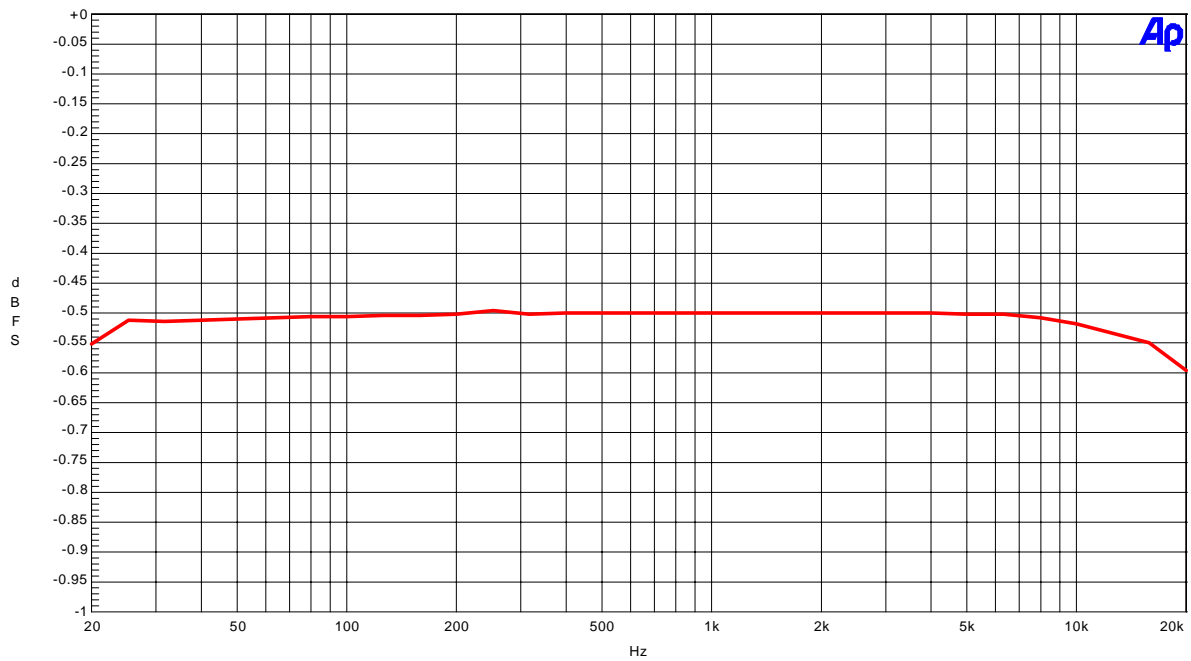

Frequency Response (Input Level=1kHz)

(fs=44.1kHz)

AKM

AK4528 ADC Crosstalk

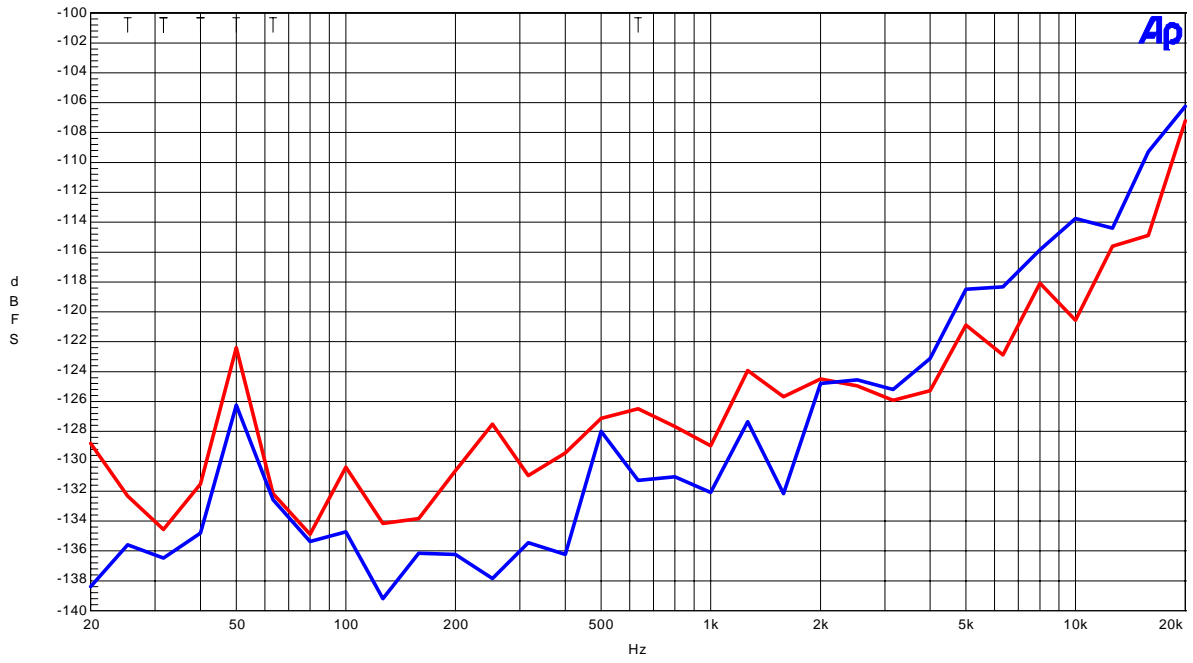

Crosstalk



(fs=96kHz)

AKM

AK4528 ADC FFT (Input Level=-0.5dBFS, fin=1kHz)

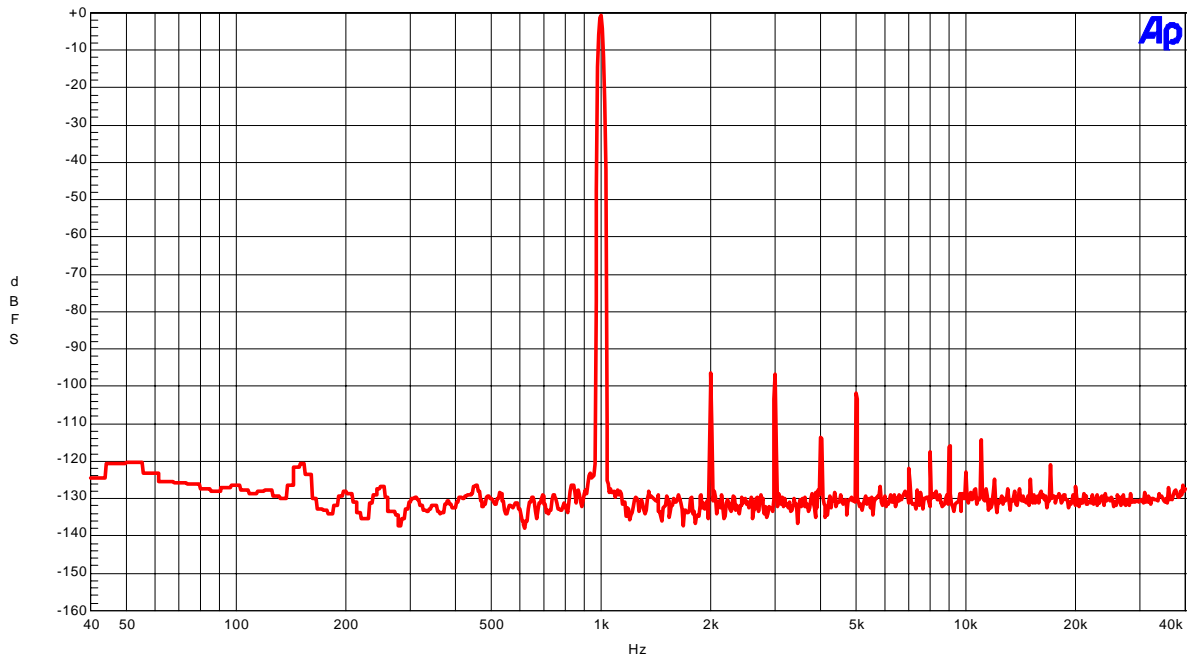

FFT (Input Level = -0.5dBFS, fin=1kHz)

AKM

AK4528 ADC FFT (Input Level=-60dBFS, fin=1kHz)

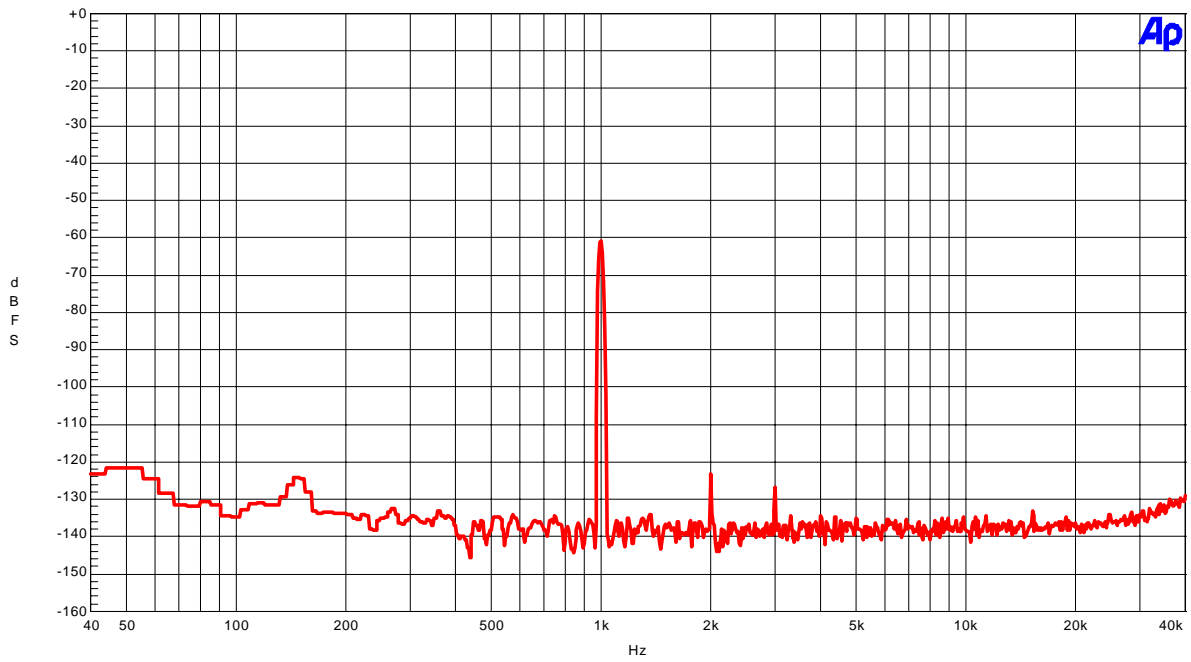

FFT (Input Level = -60dBFS, fin=1kHz)

(fs=96kHz)

AKM

AK4528 ADC FFT(noise floor)

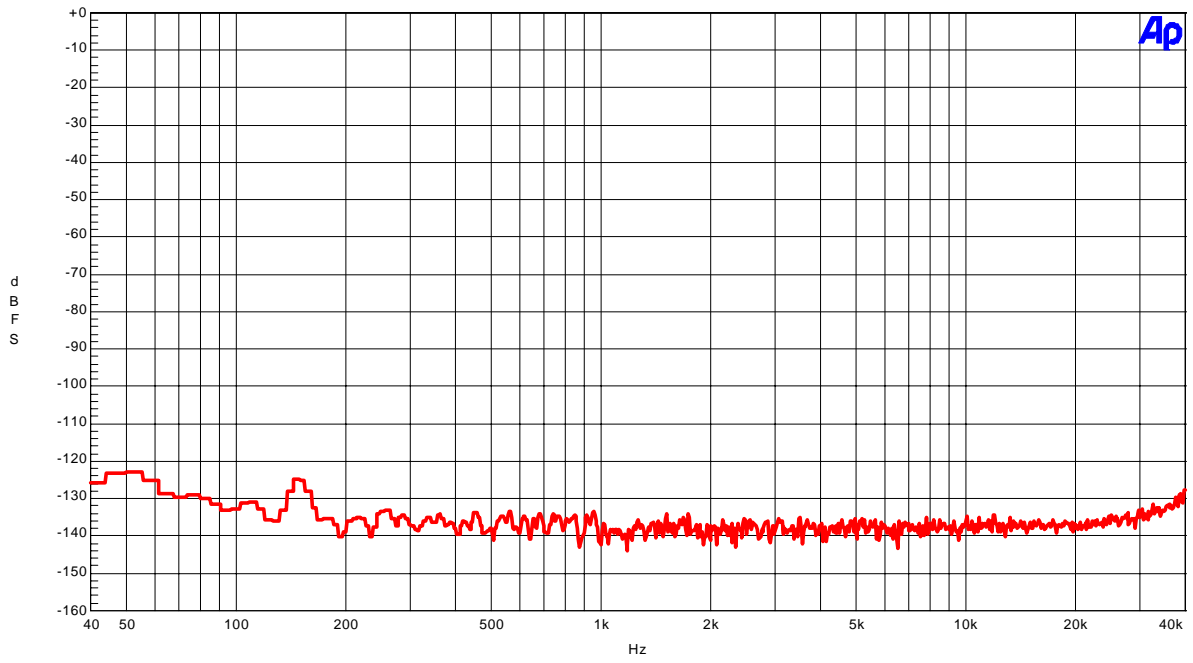

FFT (noise floor)

(fs=96kHz)

AKM

AK4528 ADC THD + N vs Amplitude(fin=1kHz)

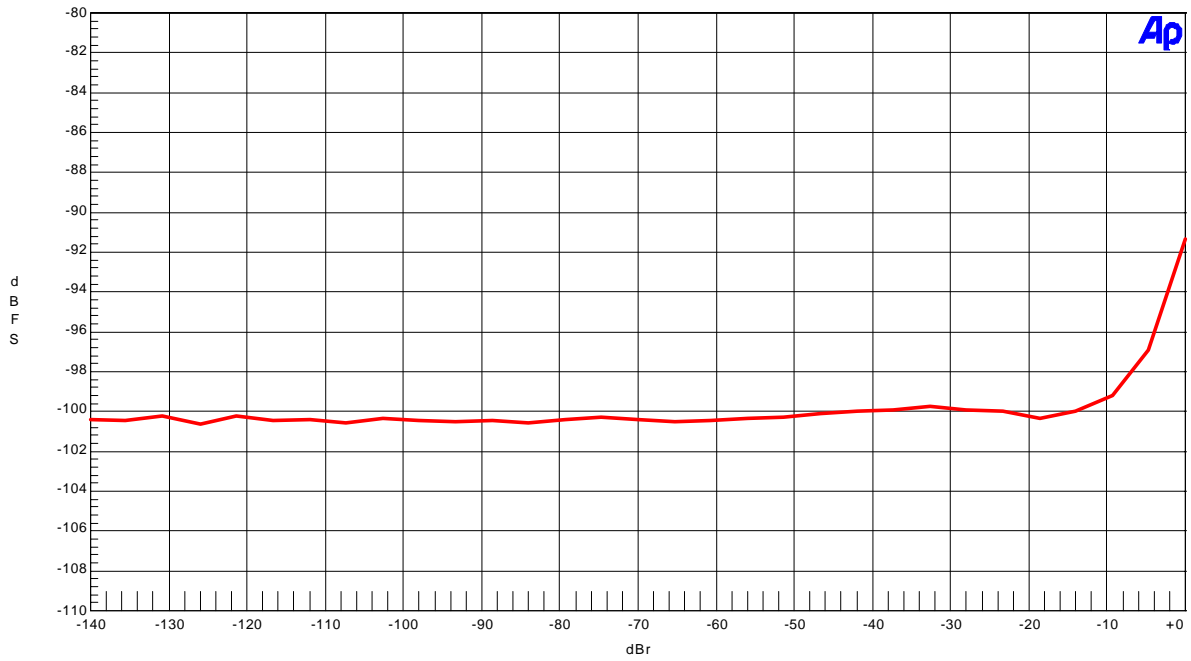

THD + N vs Amplitude (fin=1kHz)

AKM

AK4528 ADC THD + N vs Input Frequency (Input Level=-0.5dBFS)

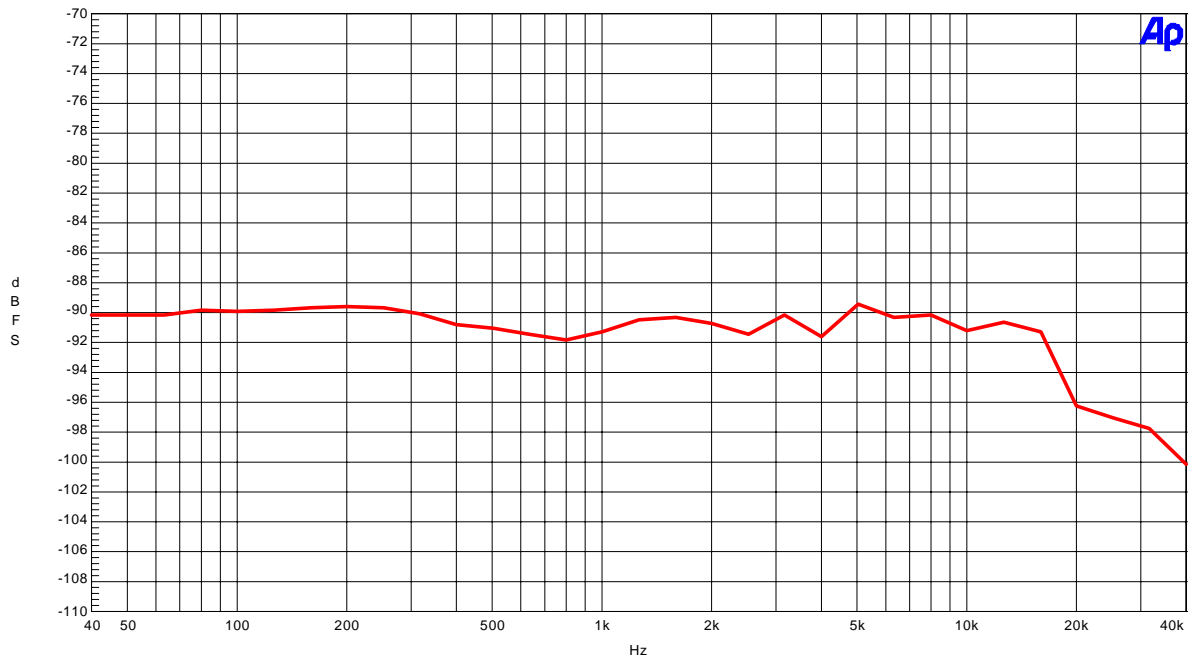

THD + N vs Input Frequency (input Level=-0.5dBFS)

(fs=96kHz)

AKM

AK4528 ADC Linearity

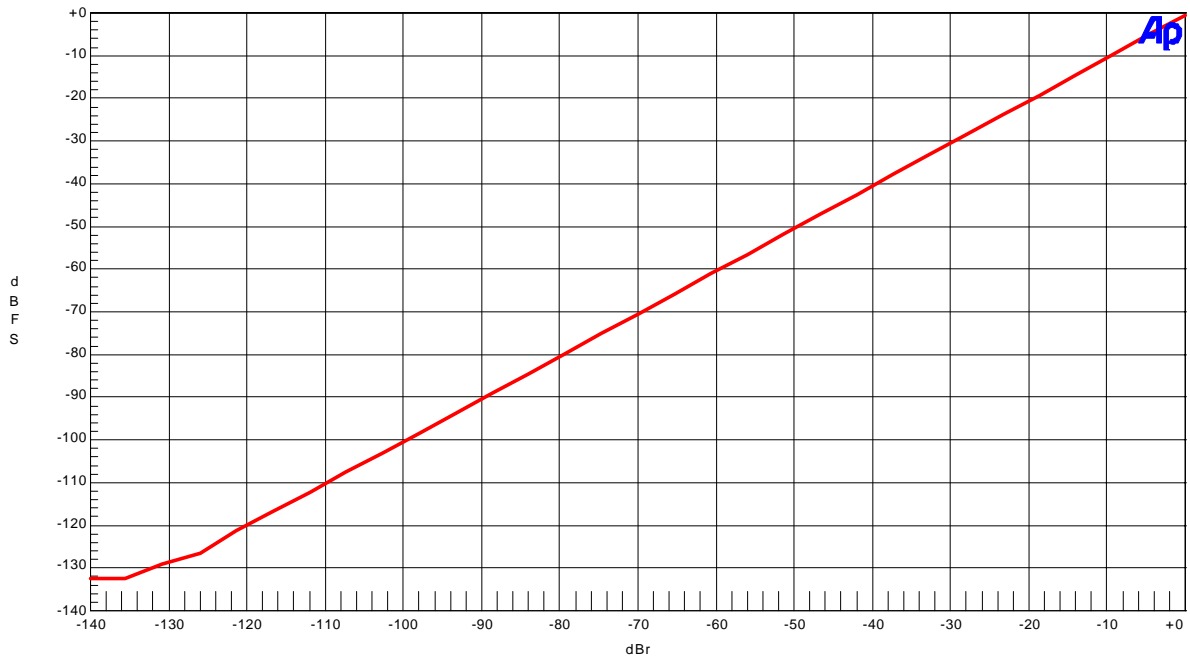

AKM

Linearity (fin=1kHz)  
AK4528 ADC Frequency Response

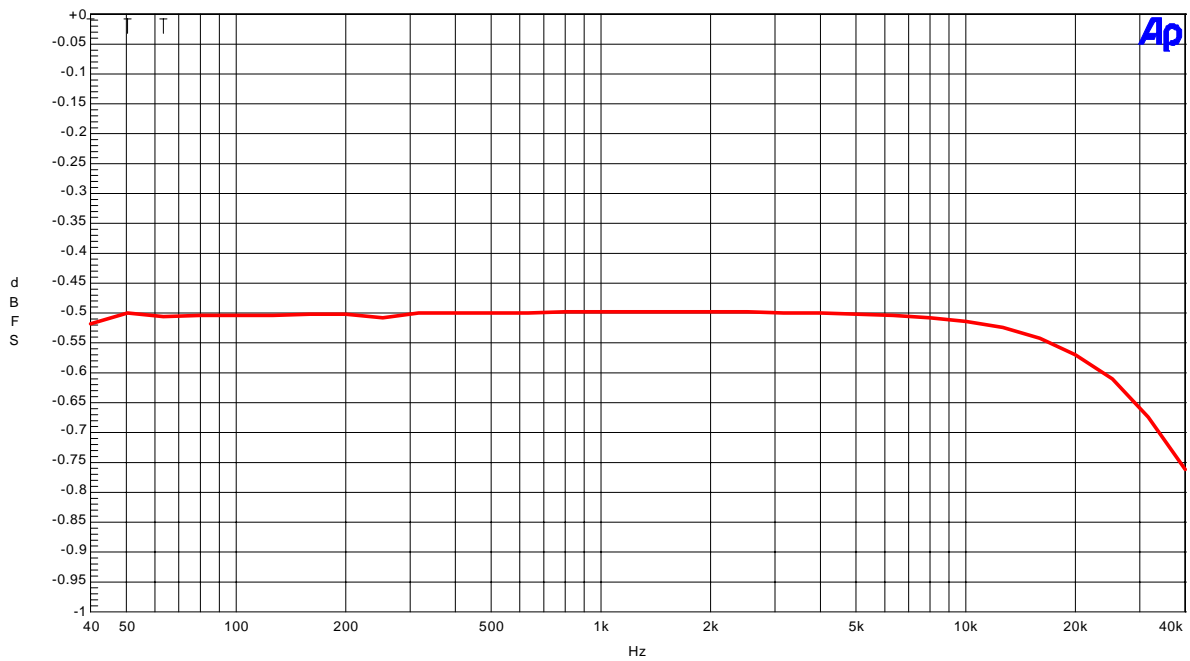

Frequency Response (Input Level=-0.5dBFS)

(fs=96kHz)

AKM

AK4528 ADC Crosstalk(Upper=Lch, Lower=Rch)

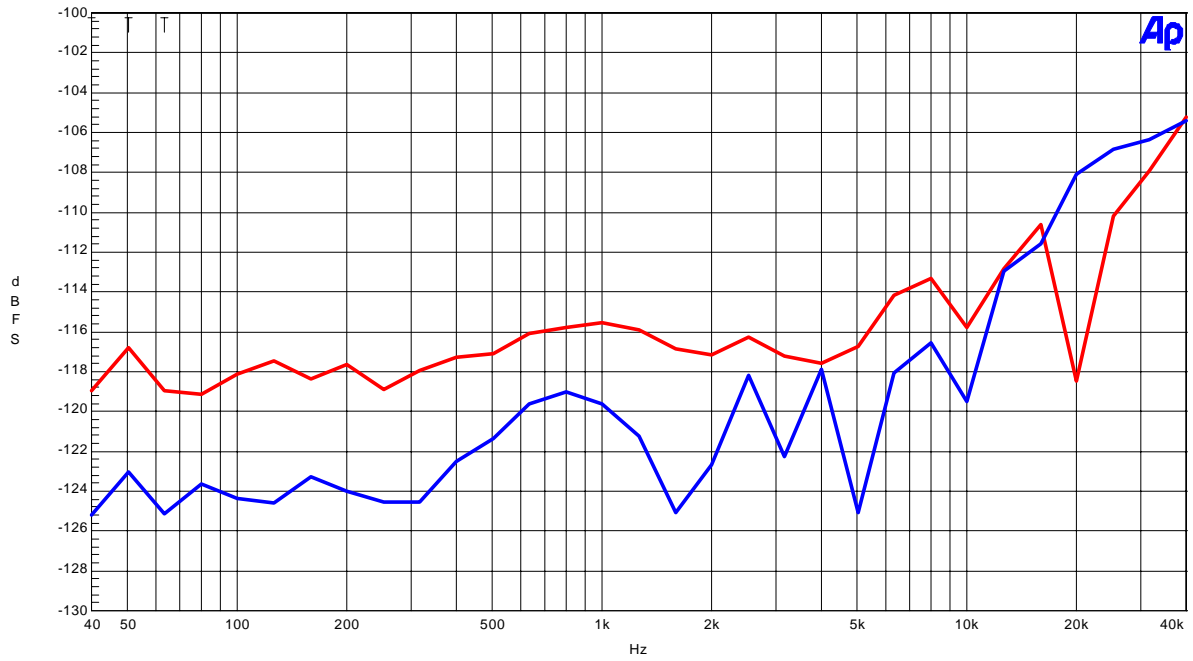

Crosstalk

(fs=44.1kHz)

2. DAC  
AKM

AK4528 DAC FFT (Input Level=0dBFS, fin=1kHz)

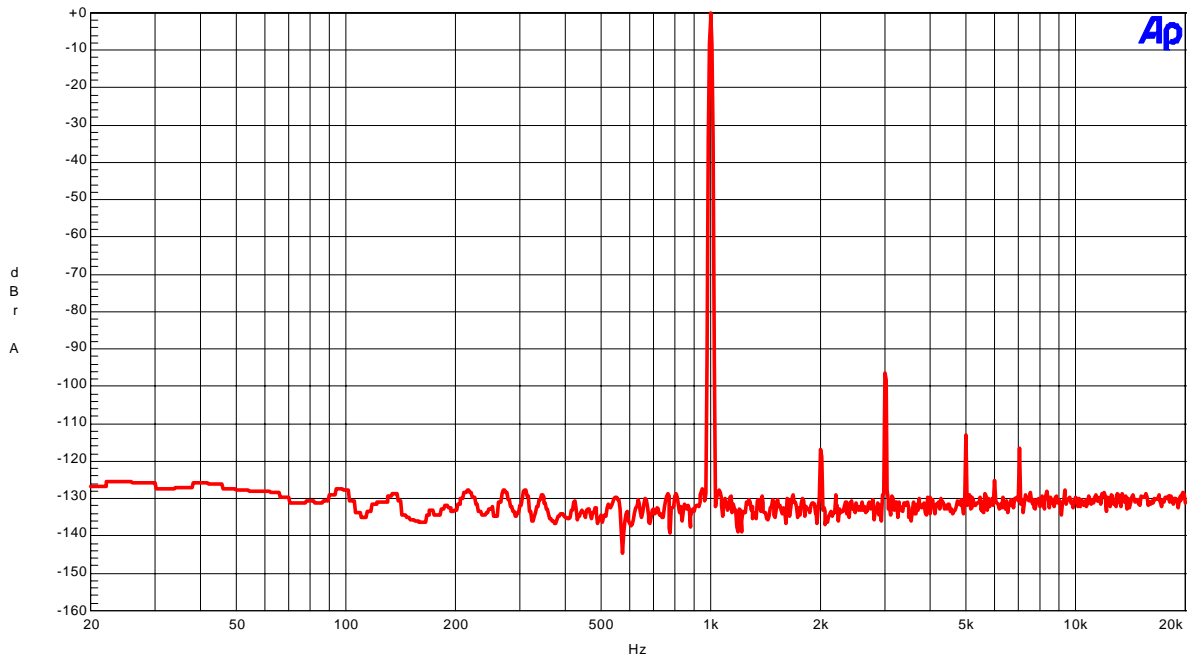

FFT (Input Level=0dBFS, fin=1kHz)

AKM

AK4528 DAC FFT (Input Level=0dBFS, fin=1kHz)

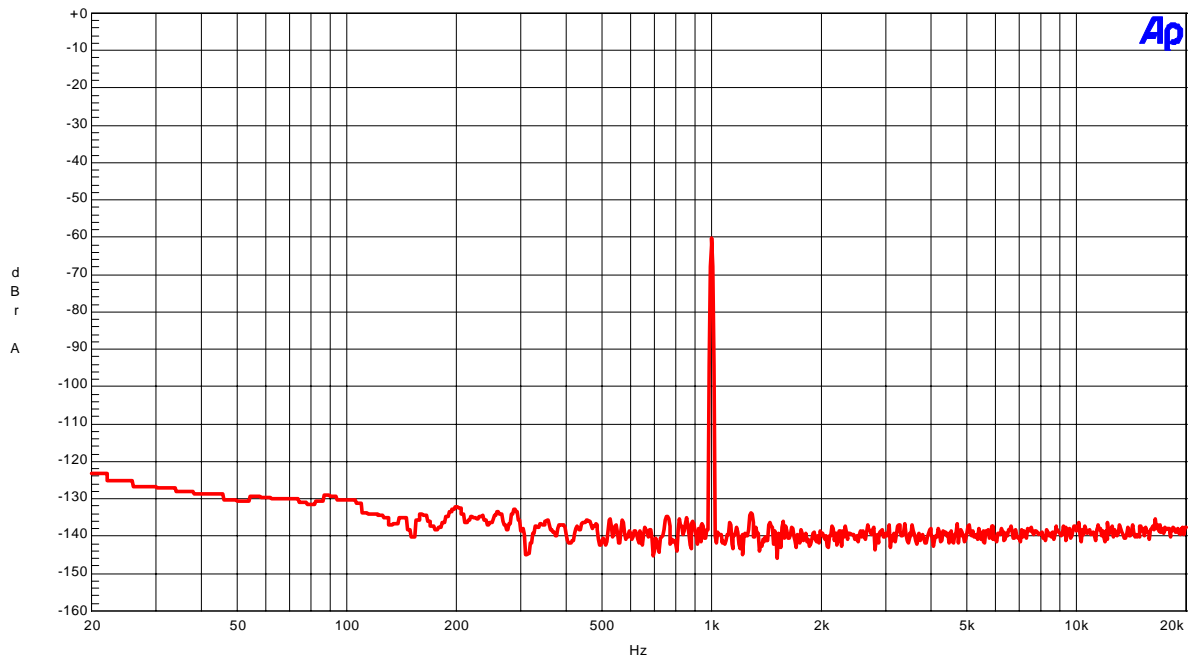

FFT (Input Level=-60dBFS, fin=1kHz)

(fs=44.1kHz)

AKM

AK4528 DAC FFT (Input=0data)

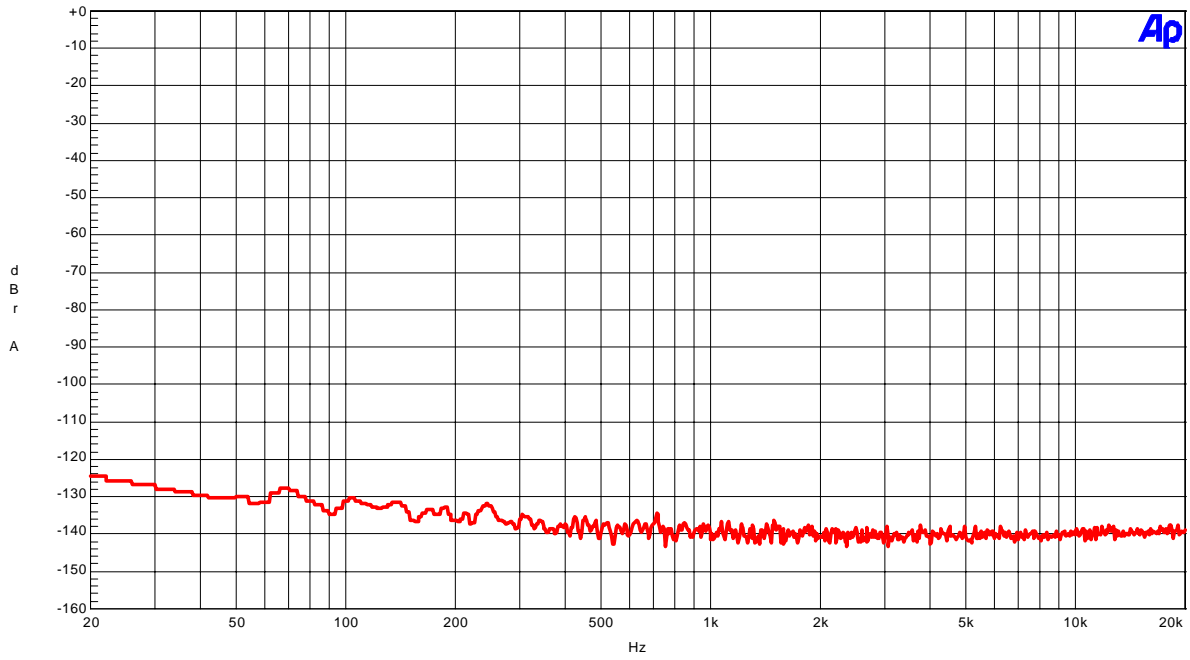

FFT (Input = "0" data)

AKM

AK4528 DAC FFT (Out-of-band noise)

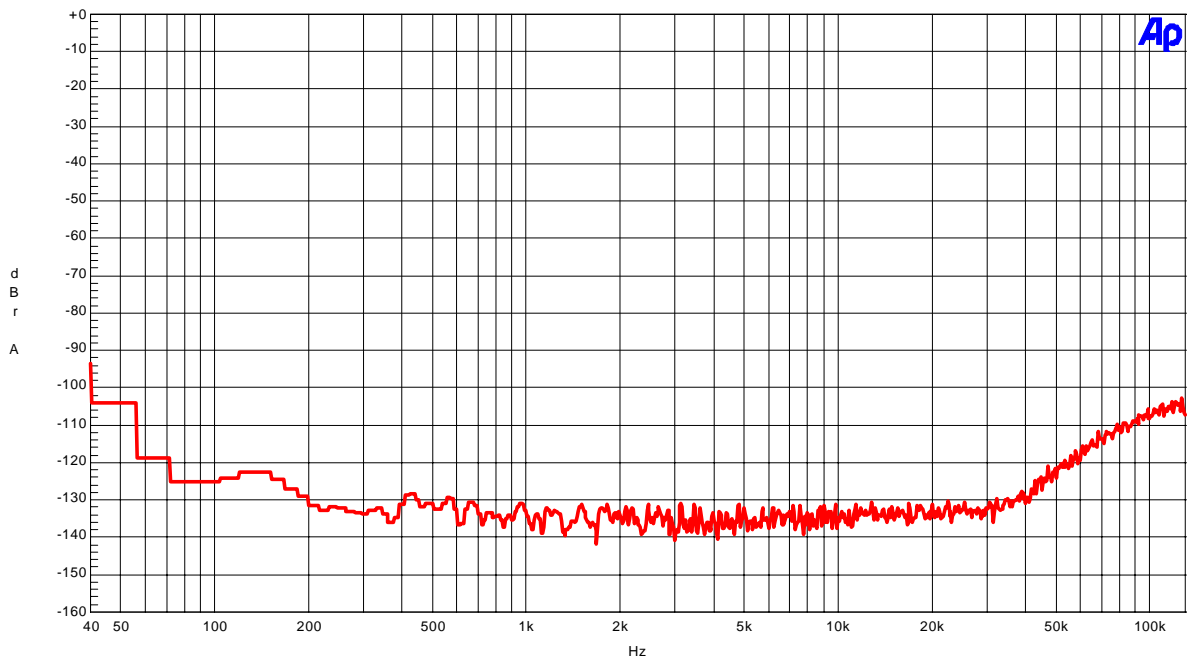

FFT (out-of-band noise)

(fs=44.1kHz)

AKM

AK4528 DAC THD + N vs Amplitude(fin=1kHz)

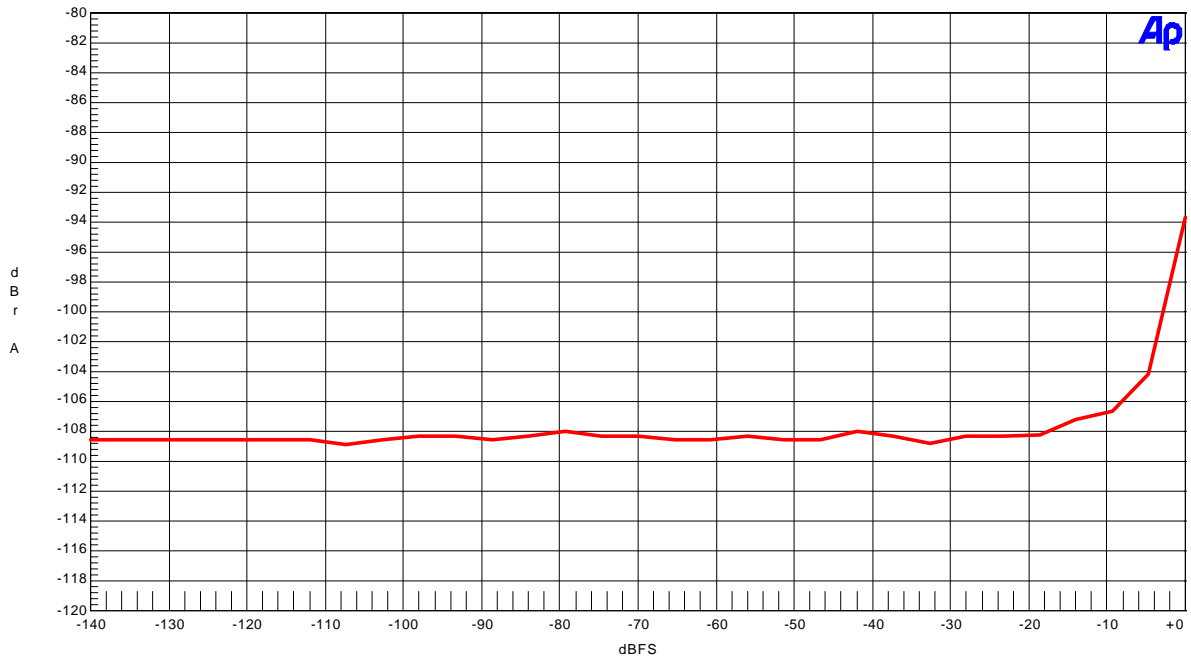

AKM

THD + N vs Amplitude (fin=1kHz)  
AK4528 DAC THD + N vs Input Frequency (Input Level=0dBFS)

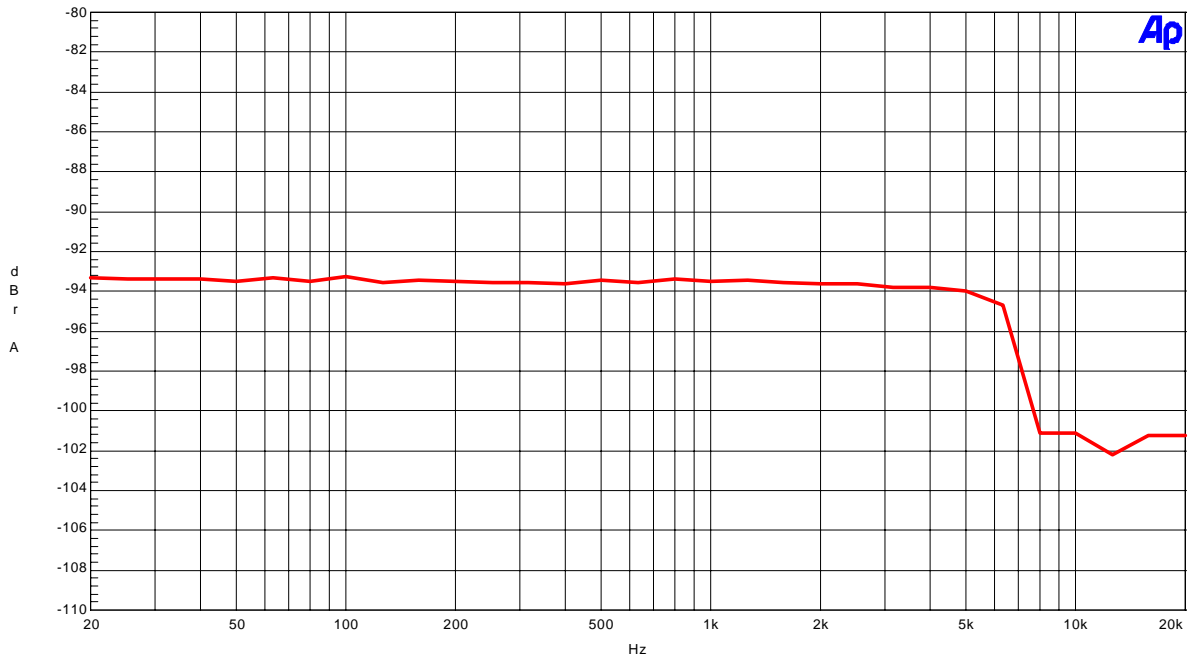

THD + N vs Input Frequency (Input Level=0dBFS)



(fs=44.1kHz)

AKM

AK4528 DAC Linearity

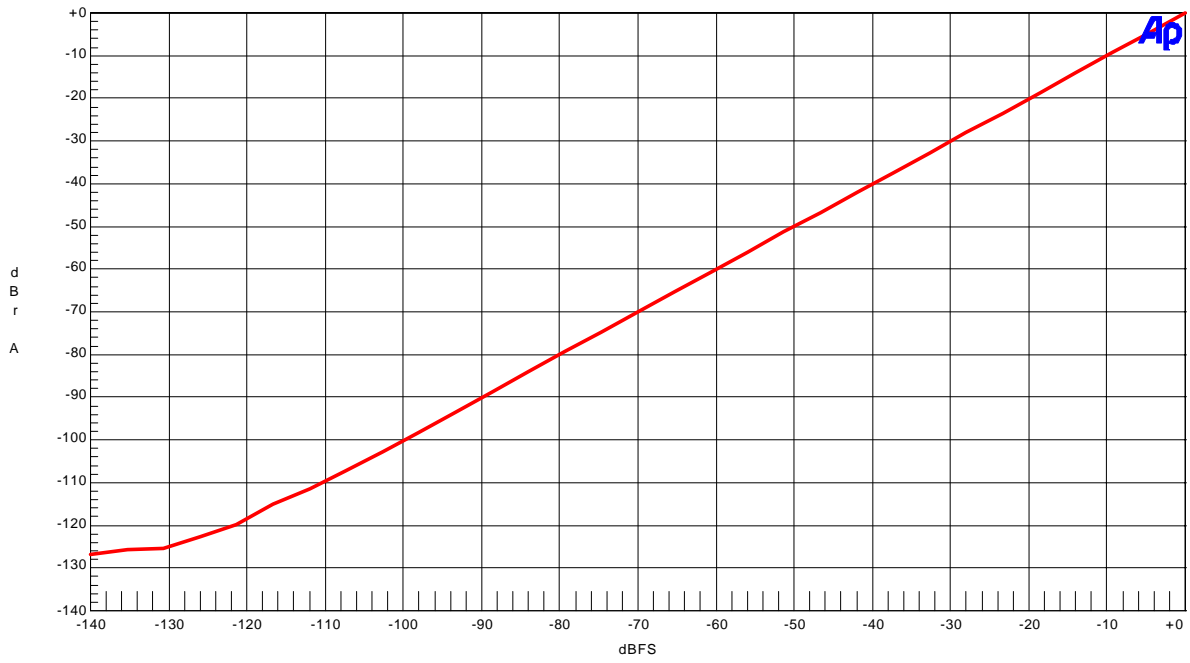

Linearity (fin=1kHz)

AKM

AK4528 DAC Frequency Response

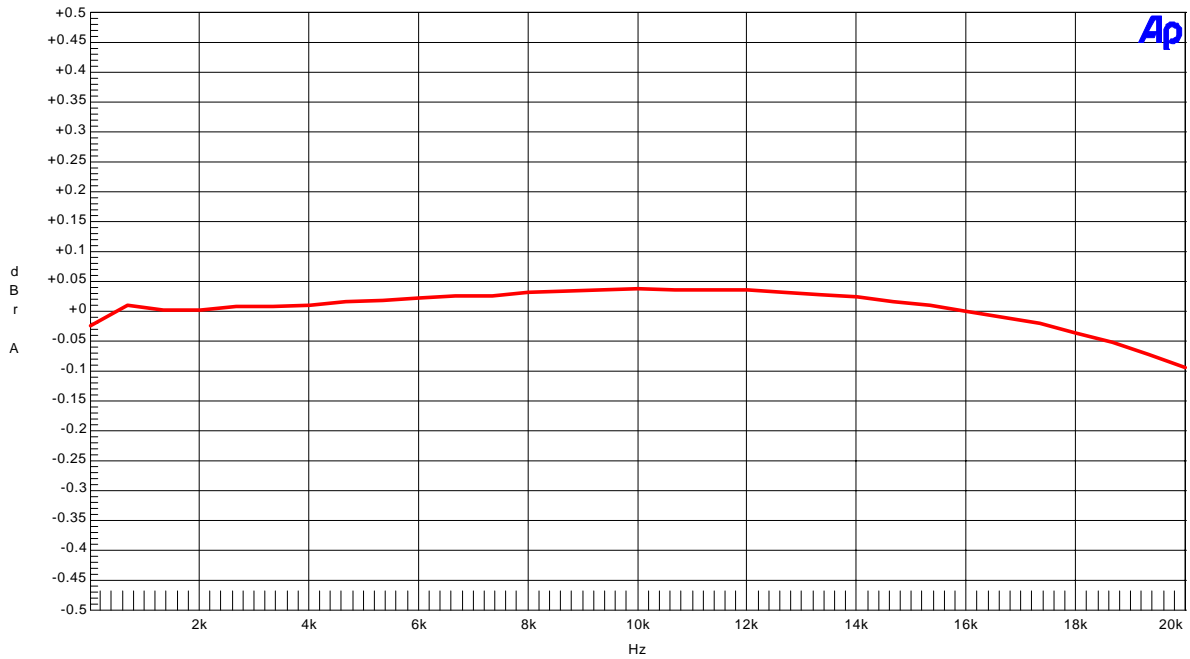

Frequency Response (Input Level = 0dBFS)

(fs=44.1kHz)

AKM

AK4528 DAC Crosstalk(Upper=Rch, Lower=Lch)

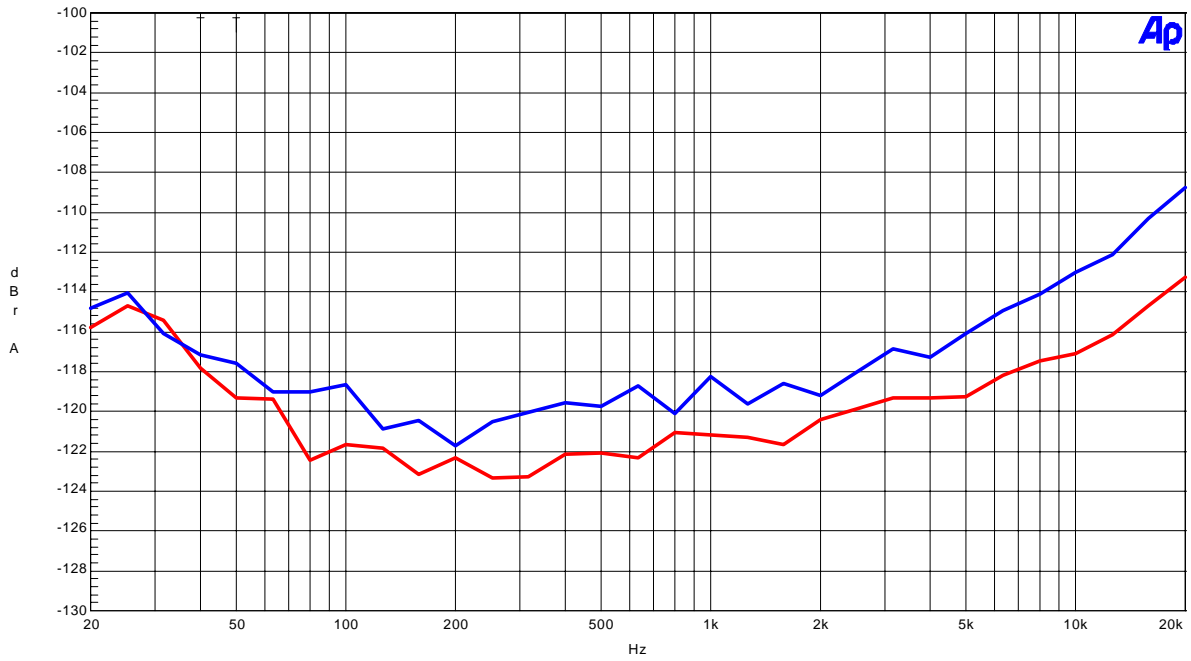

Crosstalk

(fs=96kHz)

AKM

AK4528 DAC FFT ( Input Level=0dBFS, fin=1kHz, notch ON)

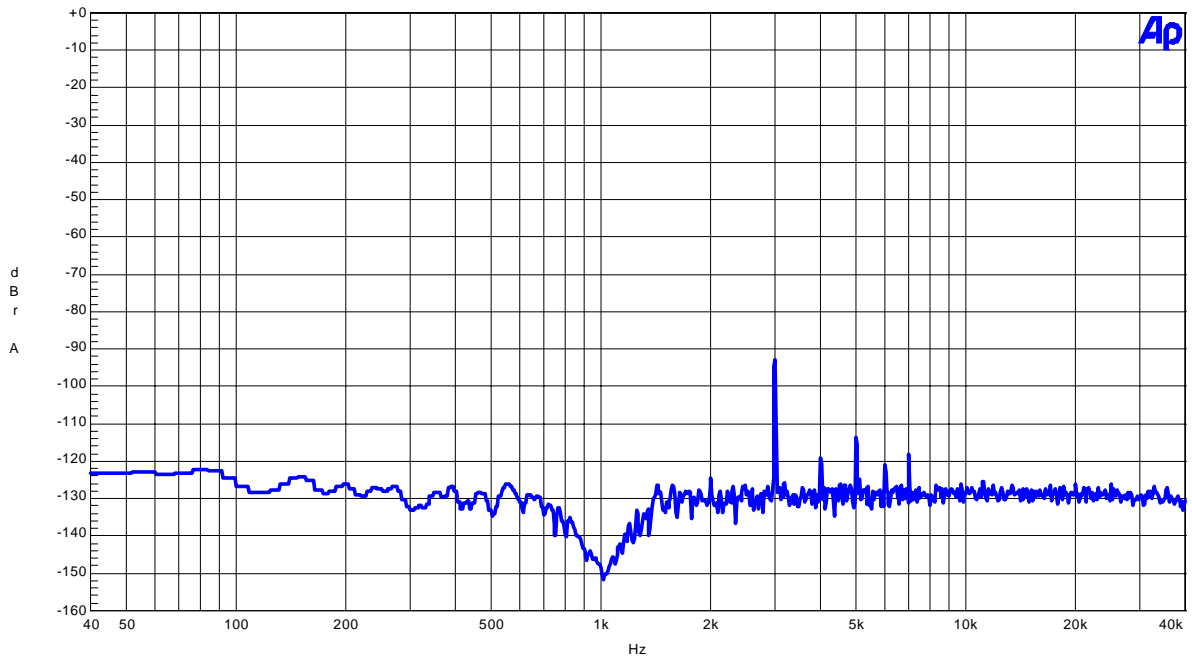

AKM

FFT (Input Level=0dBFS, fin=1kHz)  
AK4528 DAC FFT ( Input Level=-60dBFS, fin=1kHz)

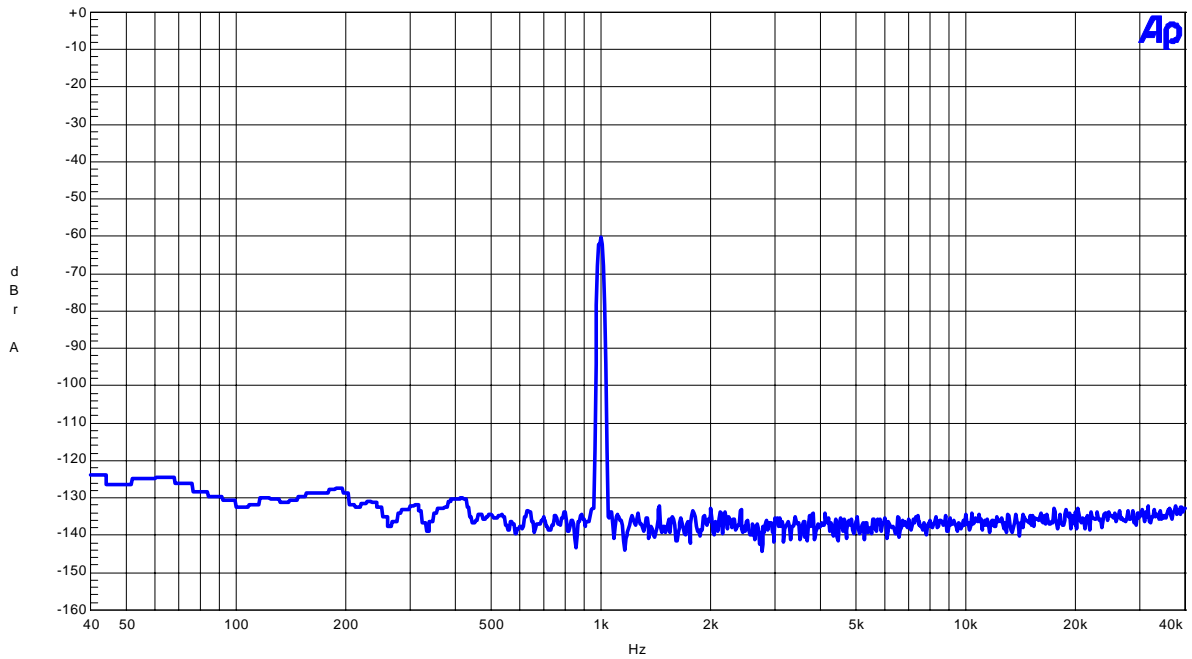

FFT (Input Level=-60dBFS, fin=1kHz)

(fs=96kHz)

AKM

AK4528 DAC FFT ( Input 0data)

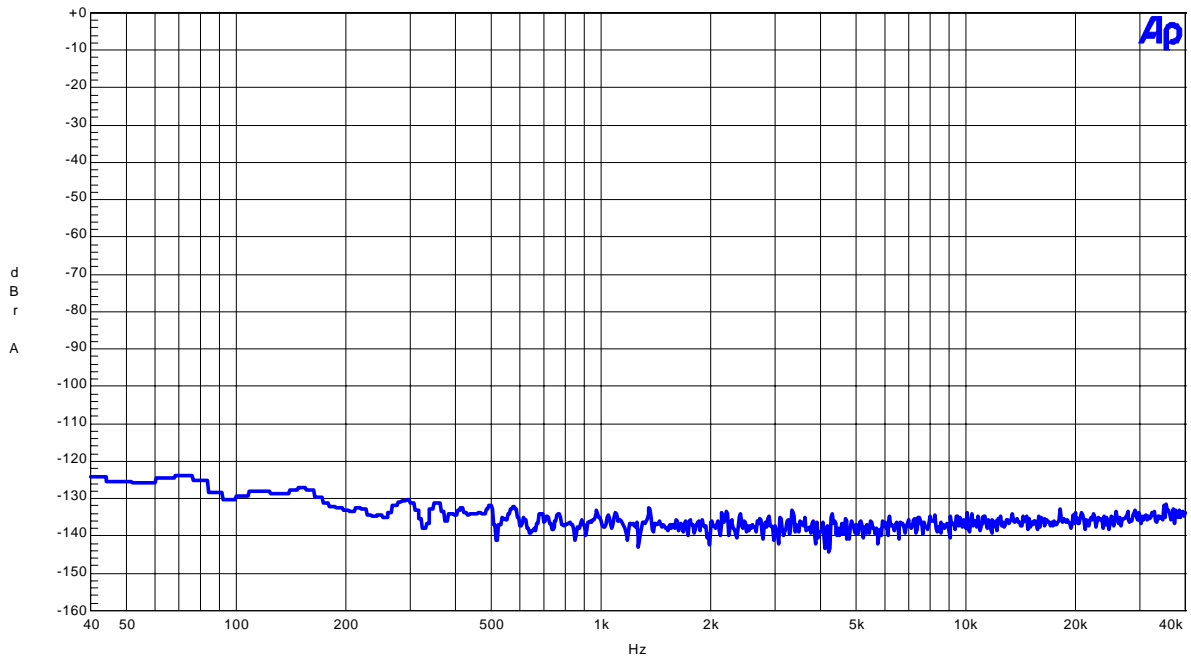

FFT (Input = "0"dBFS)

(fs=96kHz)

AKM

AK4528 DAC THD + N vs Amplitude (fin=1kHz)

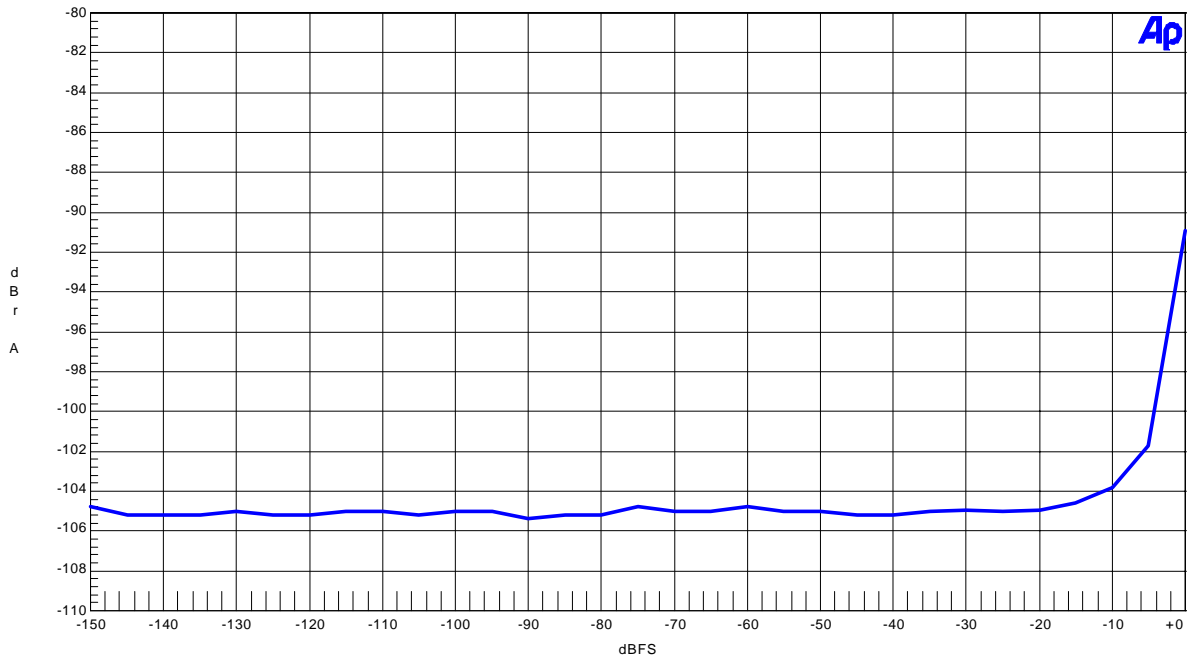

AKM

THD + N vs Amplitude (fin=1kHz)  
AK4528 DAC THD + N vs Input Frequency (Input Level=0dBFS)

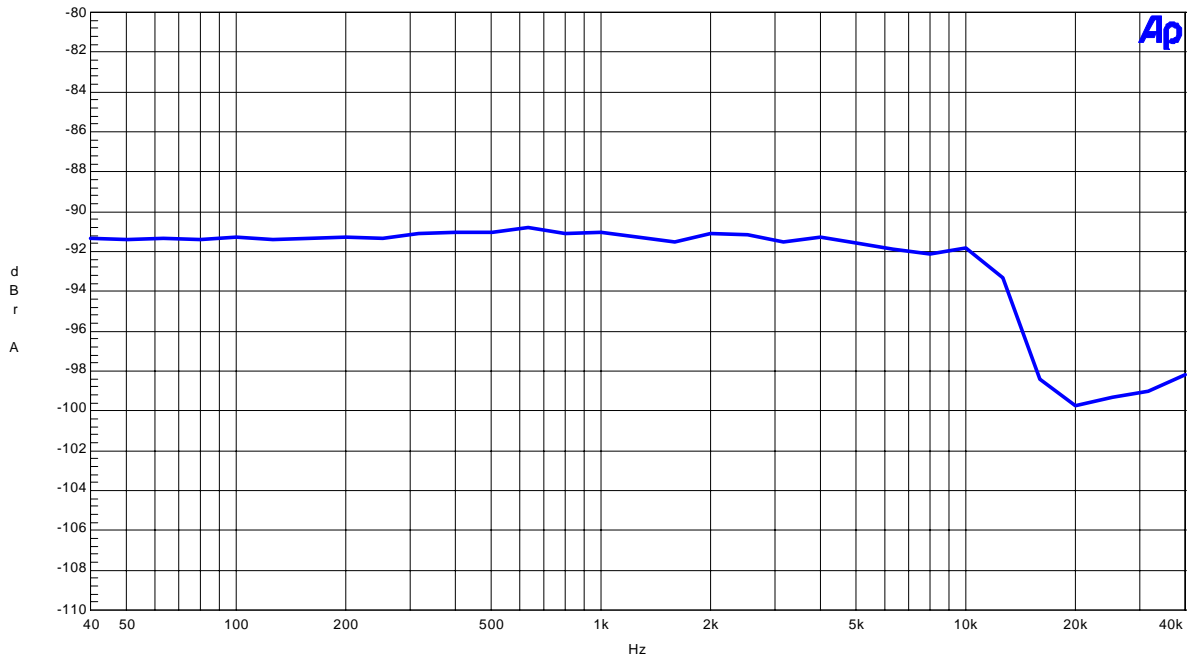

THD + N vs Input Frequency (Input Level=0dBFS)

(fs=96kHz)

AKM

AK4528 DAC Linearity

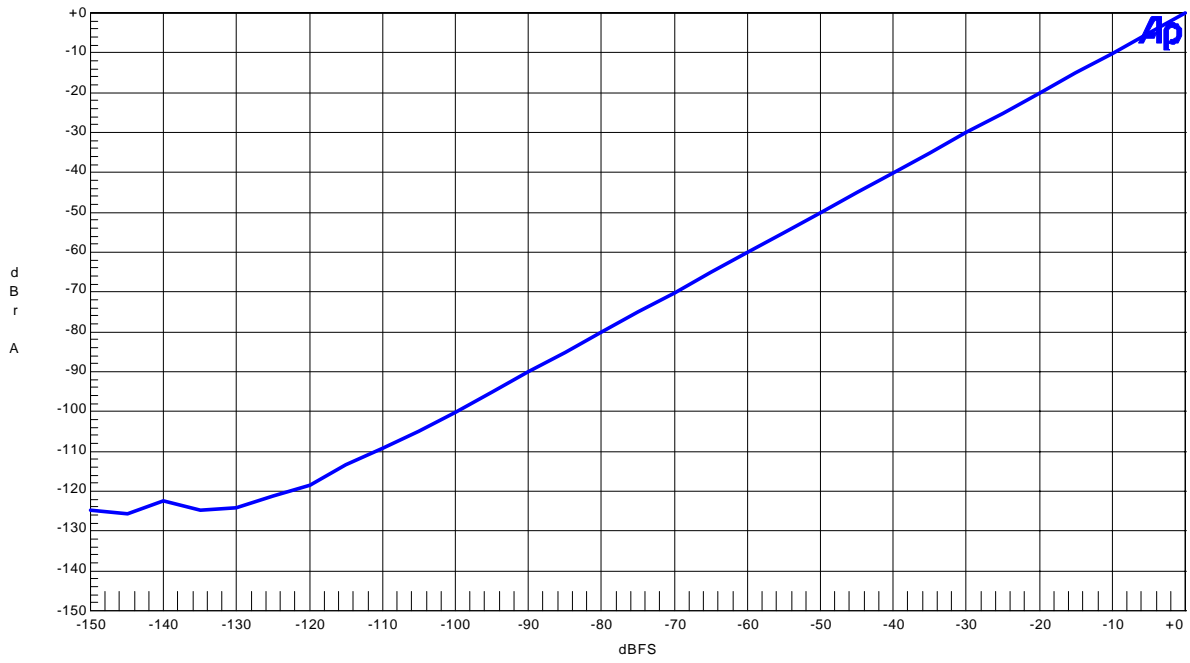

Linearity (fin=1kHz)

AKM

AK4528 DAC Frequency Response

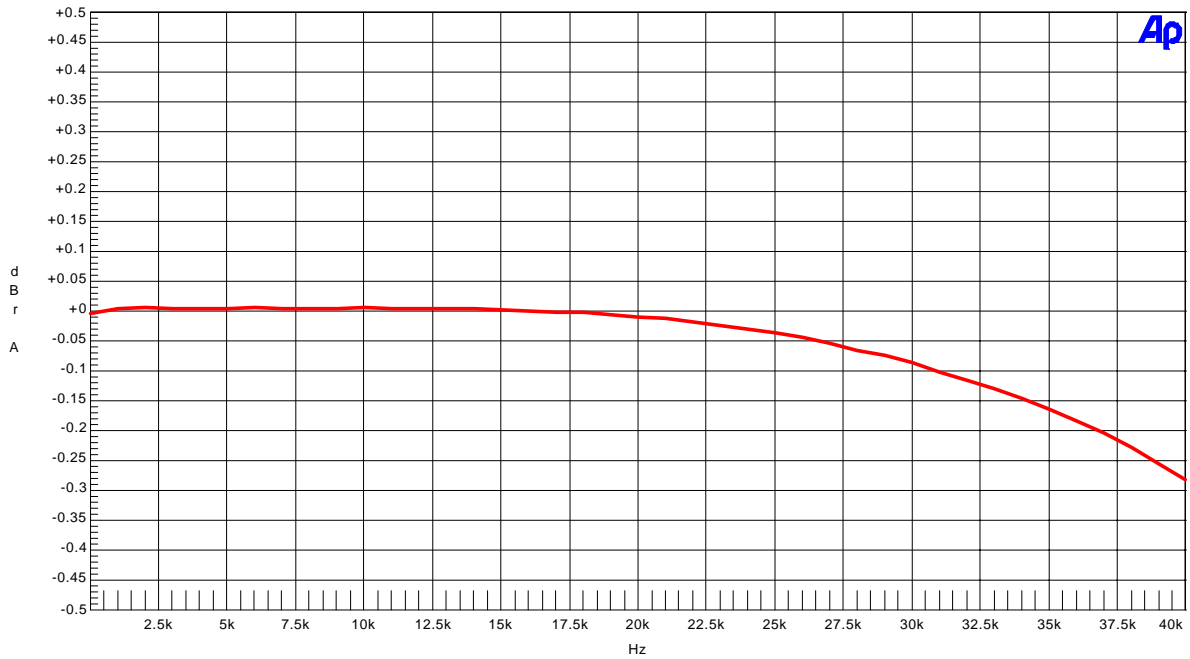

Frequency Response (Input Level=0dBFS)

(fs=96kHz)

AKM

AK4528 DAC Crosstalk

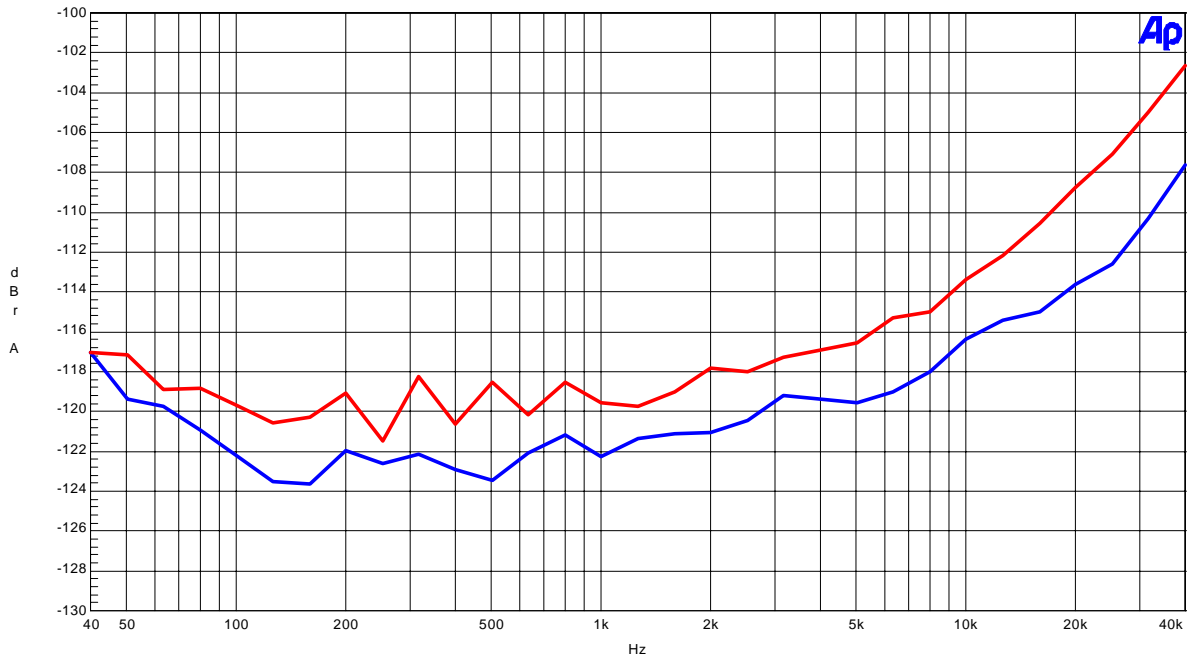

Crosstalk

**IMPORTANT NOTICE**

- These products and their specifications are subject to change without notice. Before considering any use or application, consult the Asahi Kasei Microsystems Co., Ltd. (AKM) sales office or authorized distributor concerning their current status.
- AKM assumes no liability for infringement of any patent, intellectual property, or other right in the application or use of any information contained herein.
- Any export of these products, or devices or systems containing them, may require an export license or other official approval under the law and regulations of the country of export pertaining to customs and tariffs, currency exchange, or strategic materials.
- AKM products are neither intended nor authorized for use as critical components in any safety, life support, or other hazard related device or system, and AKM assumes no responsibility relating to any such use, except with the express written consent of the Representative Director of AKM. As used here:
  - (a) A hazard related device or system is one designed or intended for life support or maintenance of safety or for applications in medicine, aerospace, nuclear energy, or other fields, in which its failure to function or perform may reasonably be expected to result in loss of life or in significant injury or damage to person or property.
  - (b) A critical component is one whose failure to function or perform may reasonably be expected to result, whether directly or indirectly, in the loss of the safety or effectiveness of the device or system containing it, and which must therefore meet very high standards of performance and reliability.
- It is the responsibility of the buyer or distributor of an AKM product who distributes, disposes of, or otherwise places the product with a third party to notify that party in advance of the above content and conditions, and the buyer or distributor agrees to assume any and all responsibility and liability for and hold AKM harmless from any and all claims arising from the use of said product in the absence of such notification.





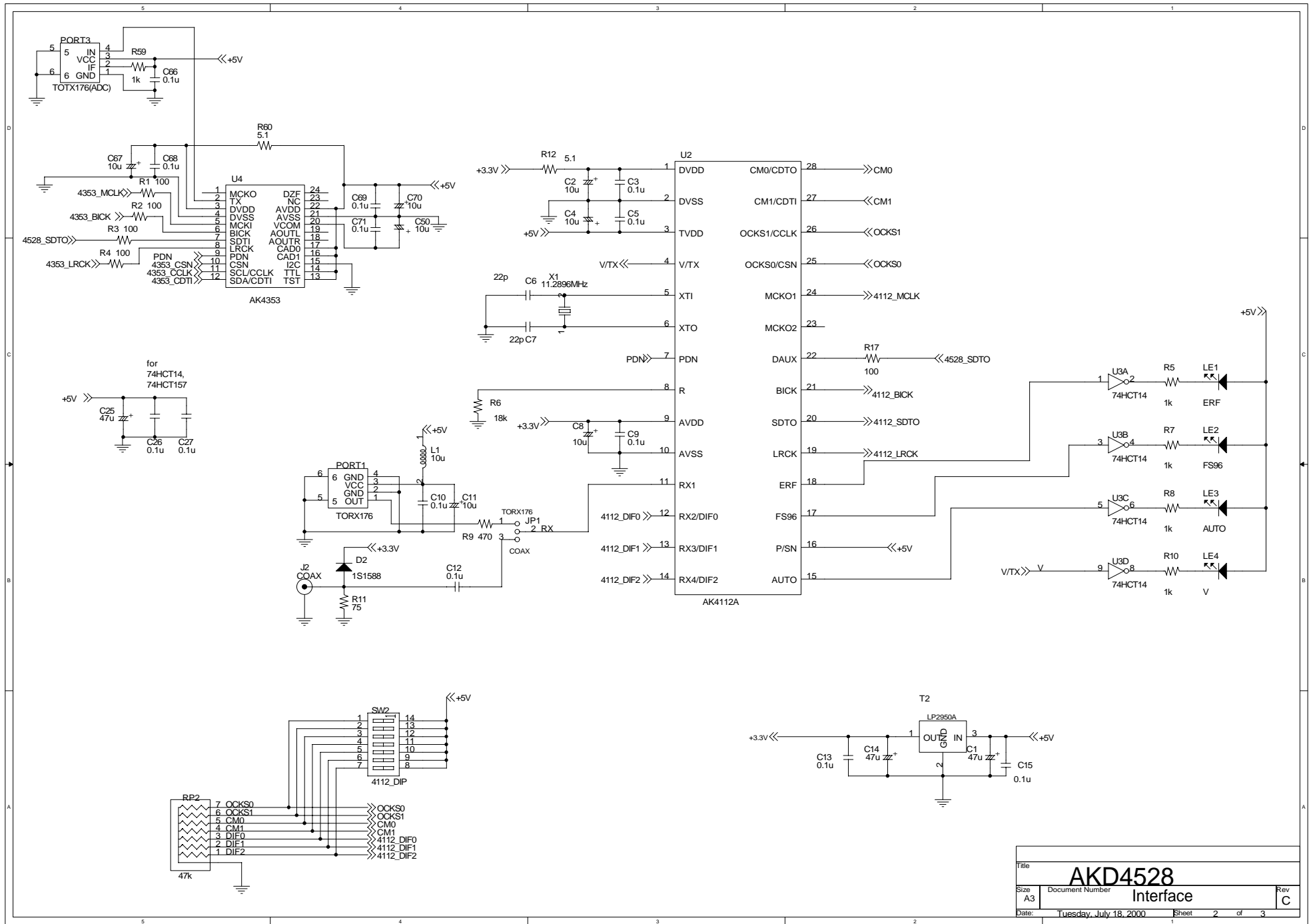

Title			Rev
AKD4528 Interface			
Size	Document Number	Date: Tuesday, July 18, 2000	
A3		Sheet	2 of 3

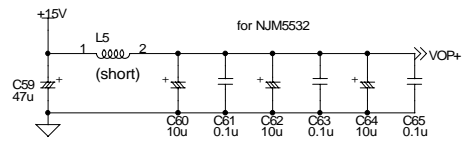
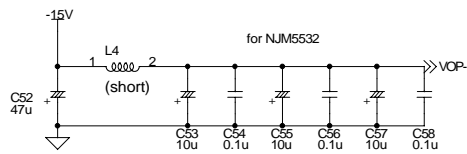
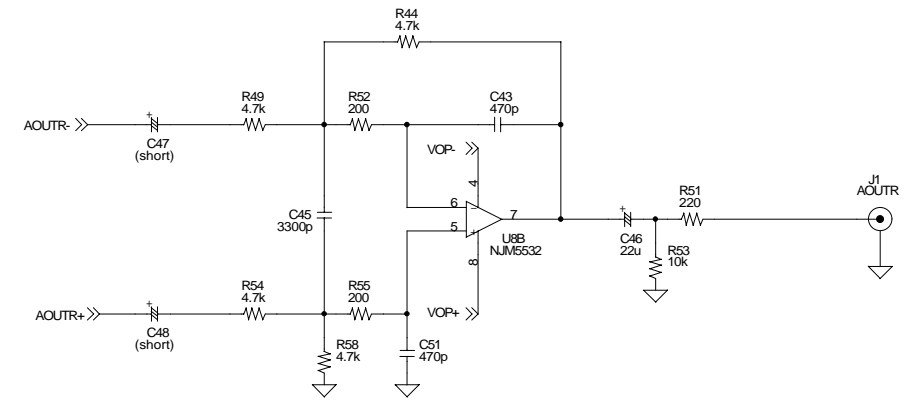
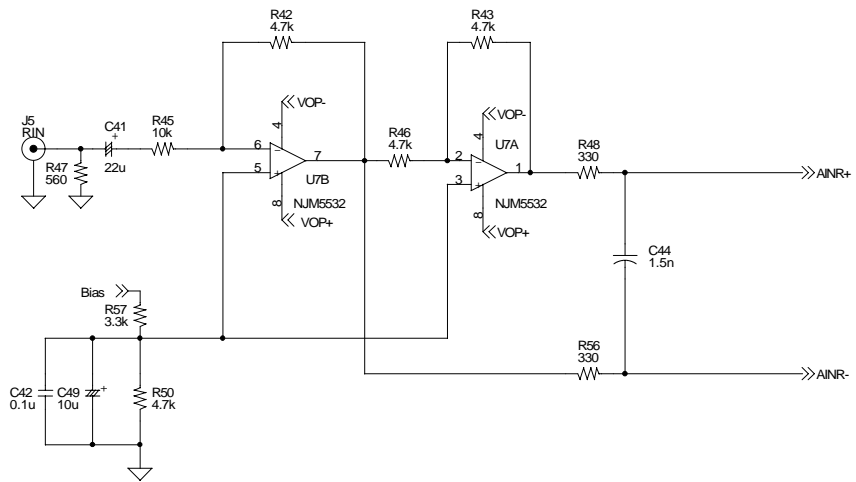
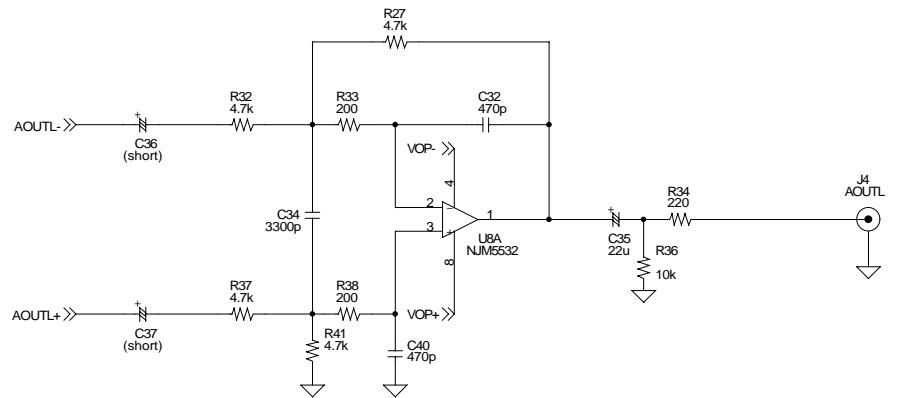
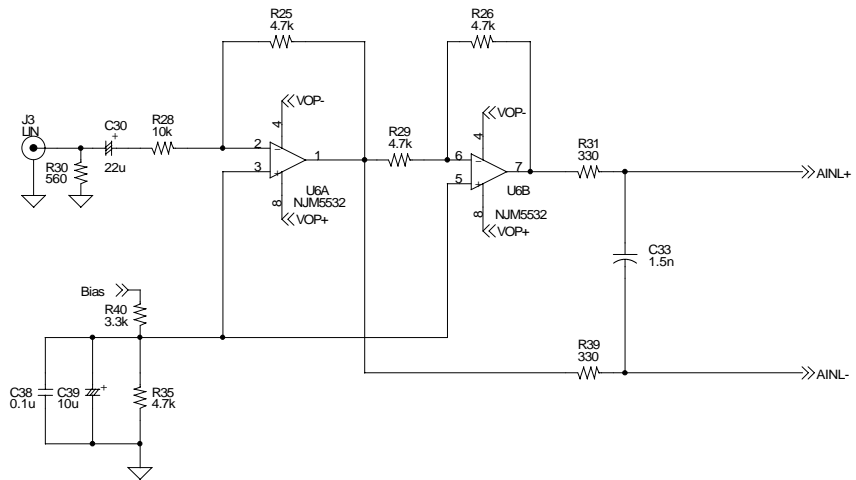

Title			
<b>AKD4528</b>			
Size	Document Number	Rev	
A3	Analog I/O	C	
Date:	Thursday, April 13, 2000	Sheet	3 of 3

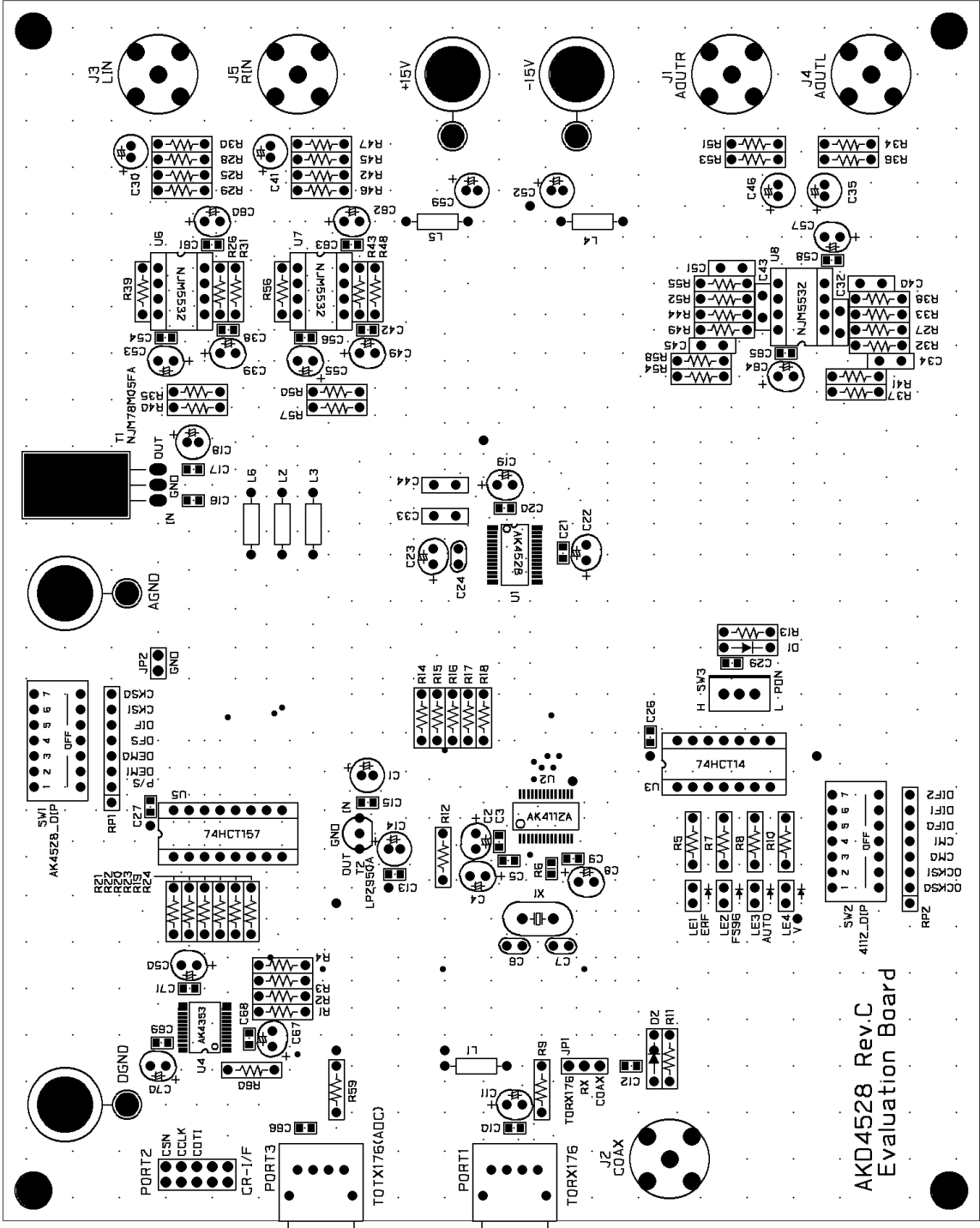

AKD4528 Rev.C  
Evaluation Board

AKD4528 Rev.C L1 SR SILK

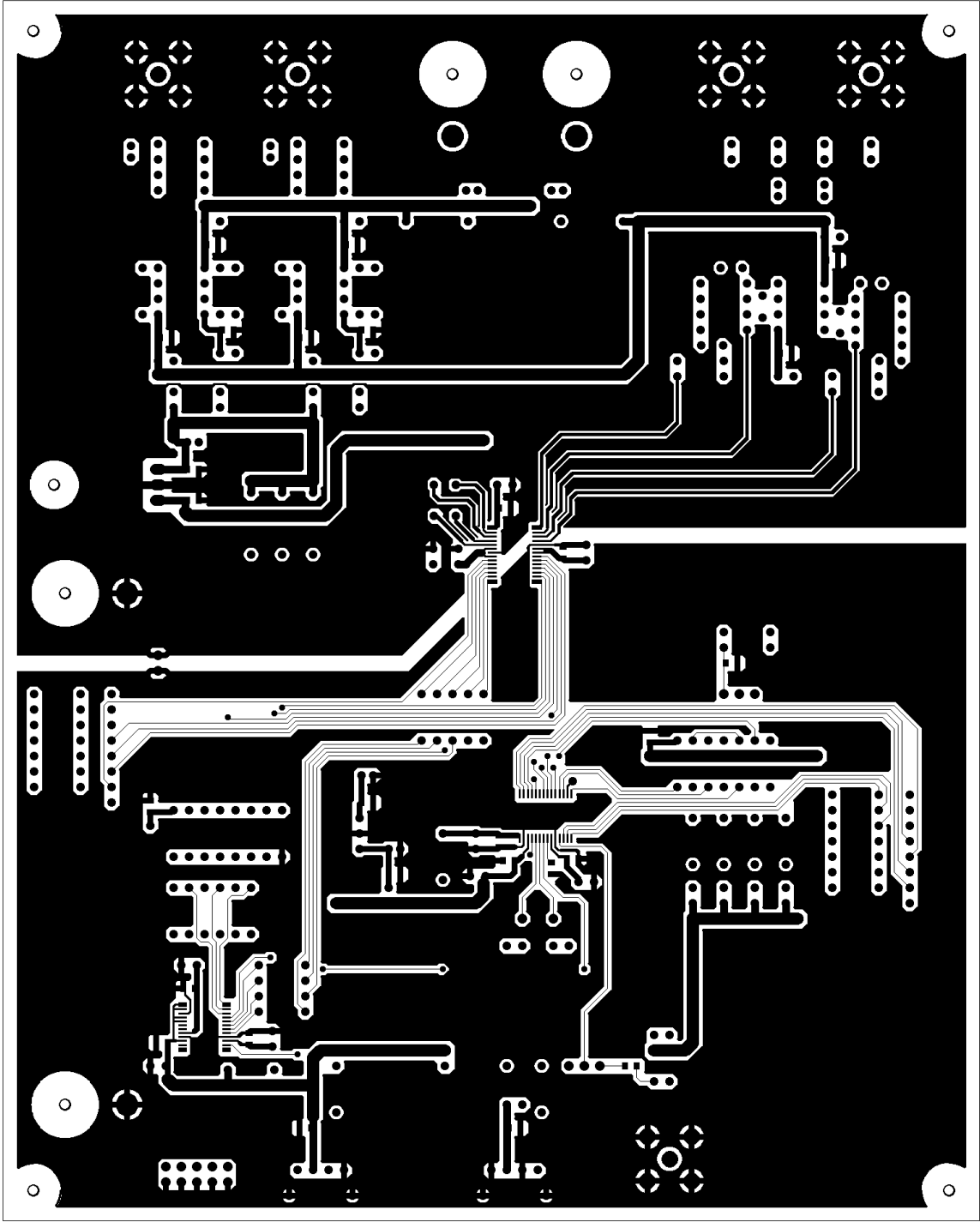

AKD4528 Rev.C L1

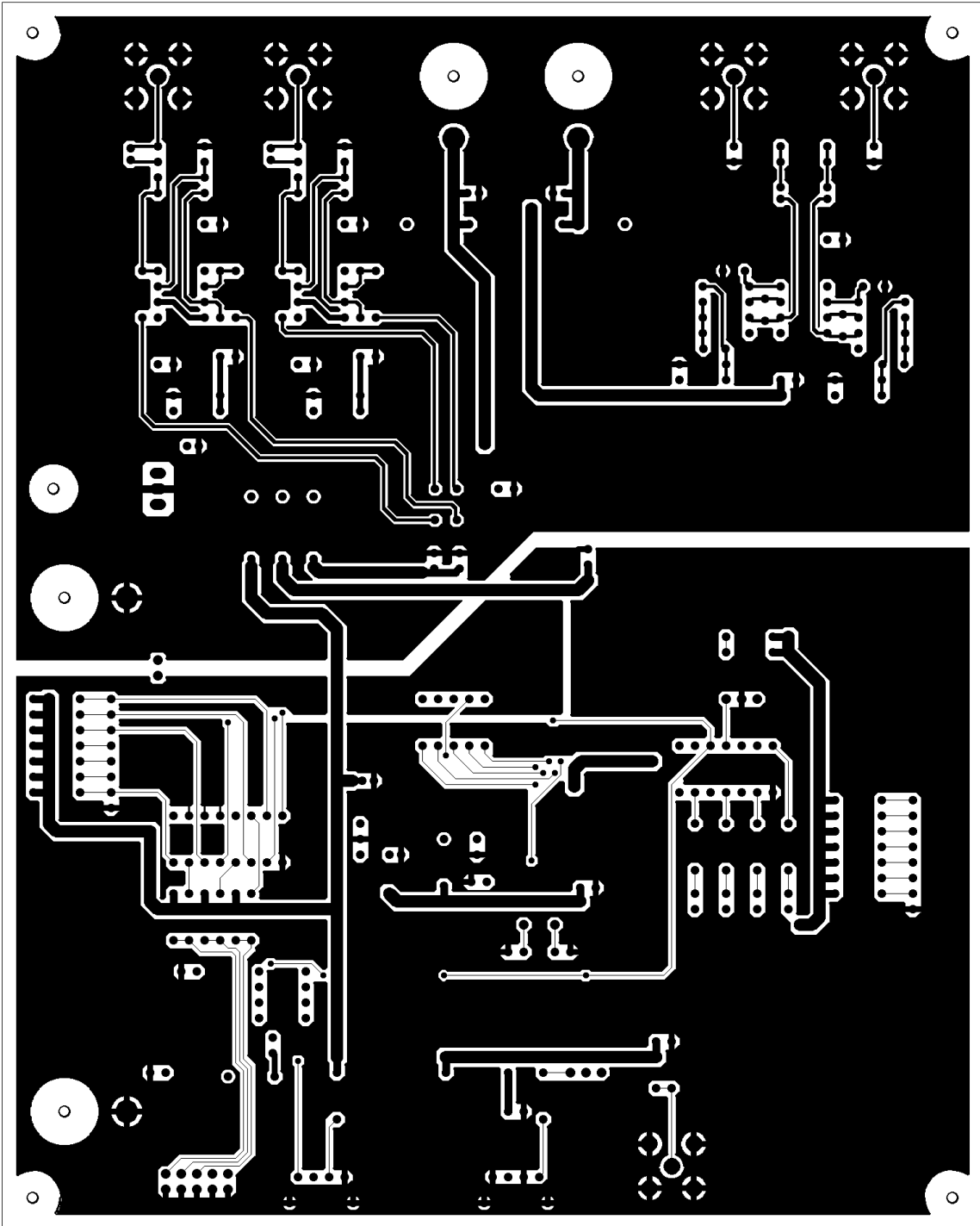

AKD42S8 REV.C 1/5