



MOTOROLA

MC14066B

QUAD ANALOG SWITCH/QUAD MULTIPLEXER

The MC14066B consists of four independent switches capable of controlling either digital or analog signals. This quad bilateral switch is useful in signal gating, chopper, modulator, demodulator and CMOS logic implementation.

The MC14066B is designed to be pin-for-pin compatible with the MC14016B, but has much lower ON resistance. Input voltage swings as large as the full supply voltage can be controlled via each independent control input.

- Triple Diode Protection on All Control Inputs
- Supply Voltage Range = 3.0 Vdc to 18 Vdc
- Linearized Transfer Characteristics
- Low Noise — 12 nV/ $\sqrt{\text{Cycle}}$, $f \approx 1.0$ kHz typical
- Pin-for-Pin Replacement for CD4016, CD4016, MC14016B
- For Lower R_{ON} , Use The HC4066 High-Speed CMOS Device

MAXIMUM RATINGS* (Voltages Referenced to V_{SS})

Symbol	Parameter	Value	Unit
V_{DD}	DC Supply Voltage	-0.5 to +18.0	V
V_{in}, V_{out}	Input or Output Voltage (DC or Transient)	-0.5 to $V_{DD} + 0.5$	V
I_{in}	Input Current (DC or Transient), per Control Pin	± 10	mA
I_{sw}	Switch Through Current	± 25	mA
P_D	Power Dissipation, per Package†	500	mW
T_{stg}	Storage Temperature	-65 to +150	°C
T_L	Lead Temperature (8-Second Soldering)	260	°C

*Maximum Ratings are those values beyond which damage to the device may occur.
 †Temperature Derating: Plastic "P and D/DW" Packages: -7.0 mW/°C From 65°C To 125°C
 Ceramic "L" Packages: -12 mW/°C From 100°C To 125°C

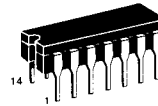

L SUFFIX
CERAMIC
CASE 632

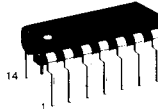

P SUFFIX
PLASTIC
CASE 646



D SUFFIX
SOIC
CASE 751A

ORDERING INFORMATION

MC14XXXBCP Plastic
 MC14XXXBCL Ceramic
 MC14XXXBD SOIC

$T_A = -55^\circ$ to 125° C for all packages.

6

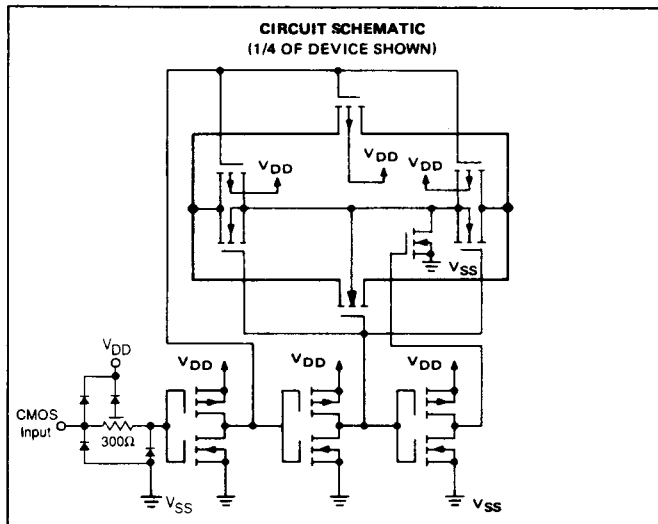
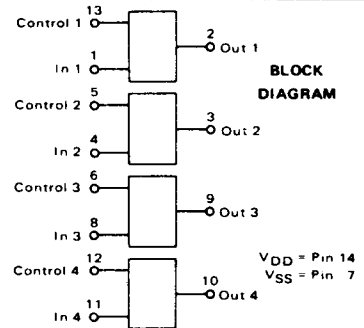

LOGIC DIAGRAM AND TRUTH TABLE
 (1/4 OF DEVICE SHOWN)

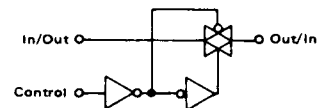

Control	Switch	Logic Diagram Restrictions
0 = V_{SS}	OFF	$V_{SS} \leq V_{in} \leq V_{DD}$
1 = V_{DD}	ON	$V_{SS} \leq V_{out} \leq V_{DD}$

MC14066B

ELECTRICAL CHARACTERISTICS

Characteristic	Symbol	V _{DD}	Test Conditions	-55°C		25°C			125°C		Unit
				Min	Max	Min	Typ #	Max	Min	Max	
SUPPLY REQUIREMENTS (Voltages Referenced to V_{EE})											
Power Supply Voltage Range	V _{DD}	—		3.0	18	3.0	—	18	3.0	18	V
Quiescent Current Per Package	I _{DD}	5.0 10 15	Control Inputs: V _{in} = V _{SS} or V _{DD} . Switch I/O: V _{SS} ≤ V _{I/O} ≤ V _{DD} , and ΔV _{switch} ≤ 500 mV**	— — —	0.25 0.5 1.0	— — —	0.005 0.010 0.015	0.25 0.5 1.0	— — —	7.5 15 30	μA
Total Supply Current (Dynamic Plus Quiescent, Per Package)	I _{D(AV)}	5.0 10 15	T _A = 25°C only The channel component, (V _{in} - V _{out})/R _{on} , is not included.)	Typical			(0.07 μA/kHz)f + (0.20 μA/kHz)f + (0.36 μA/kHz)f +	I _{DD} I _{DD} I _{DD}			μA
CONTROL INPUTS (Voltages Referenced to V_{SS})											
Low-Level Input Voltage	V _{IL}	5.0 10 15	R _{on} = per spec, I _{off} = per spec	— — —	1.5 3.0 4.0	— — —	2.25 4.50 6.75	1.5 3.0 4.0	— — —	1.5 3.0 4.0	V
High-Level Input Voltage	V _{IH}	5.0 10 15	R _{on} = per spec, I _{off} = per spec	3.5 7.0 11	— — —	3.5 7.0 11	2.75 5.50 8.25	— — —	3.5 7.0 11	— — —	V
Input Leakage Current	I _{in}	15	V _{in} = 0 or V _{DD}	—	±0.1	—	±0.00001	±0.1	—	±1.0	μA
Input Capacitance	C _{in}	—		—	—	—	5.0	7.5	—	—	pF
SWITCHES IN AND OUT (Voltages Referenced to V_{SS})											
Recommended Peak-to-Peak Voltage Into or Out of the Switch	V _{I/O}	—	Channel On or Off	0	V _{DD}	0	—	V _{DD}	0	V _{DD}	V _{p-p}
Recommended Static or Dynamic Voltage Across the Switch** (Figure 1)	ΔV _{switch}	—	Channel On	0	600	0	—	600	0	300	mV
Output Offset Voltage	V _{OO}	—	V _{in} = 0 V, No Load	—	—	—	10	—	—	—	μV
ON Resistance	R _{on}	5.0 10 15	ΔV _{switch} ≤ 500 mV**, V _{in} = V _{IL} or V _{IH} (Control), and V _{in} = 0 to V _{DD} (Switch)	— — —	800 400 220	— — —	250 120 80	1050 500 280	— — —	1200 520 300	Ω
ΔON Resistance Between Any Two Channels in the Same Package	ΔR _{on}	5.0 10 15		— — —	70 50 45	— — —	25 10 10	70 50 45	— — —	135 95 65	Ω
Off-Channel Leakage Current (Figure 6)	I _{off}	15	V _{in} = V _{IL} or V _{IH} (Control) Channel to Channel or Any One Channel	—	±100	—	±0.05	±100	—	±1000	nA
Capacitance, Switch I/O	C _{I/O}	—	Switch Off	—	—	—	10	15	—	—	pF
Capacitance, Feedthrough (Switch Off)	C _{I/O}	—		—	—	—	0.47	—	—	—	pF

#Data labeled "Typ" is not to be used for design purposes, but is intended as an indication of the IC's potential performance.

**For voltage drops across the switch (ΔV_{switch}) >600 mV (>300 mV at high temperature), excessive V_{DD} current may be drawn; i.e. the current out of the switch may contain both V_{DD} and switch input components. The reliability of the device will be unaffected unless the Maximum Ratings are exceeded. (See first page of this data sheet.)

MC14066B

ELECTRICAL CHARACTERISTICS* ($C_L = 50$ pF, $T_A = 25^\circ\text{C}$ unless otherwise noted.)

Characteristic	Symbol	V_{DD} Vdc	Min	Typ #	Max	Unit
Propagation Delay Times Input to Output ($R_L = 10$ k Ω) $V_{SS} = 0$ Vdc $t_{PLH}, t_{PHL} = (0.17$ ns/pF) $C_L + 15.5$ ns $t_{PLH}, t_{PHL} = (0.08$ ns/pF) $C_L + 6.0$ ns $t_{PLH}, t_{PHL} = (0.06$ ns/pF) $C_L + 4.0$ ns Control to Output ($R_L = 1$ k Ω) (Figure 2) Output "1" to High Impedance	t_{PLH}, t_{PHL}	5.0 10 15	— — —	20 10 7.0	40 20 15	ns
Output "1" to High Impedance	t_{PHZ}	5.0 10 15	— — —	40 35 30	80 70 60	ns
Output "0" to High Impedance	t_{PLZ}	5.0 10 15	— — —	40 35 30	80 70 60	ns
High Impedance to Output "1"	t_{PZH}	5.0 10 15	— — —	60 20 15	120 40 30	ns
High Impedance to Output "0"	t_{PZL}	5.0 10 15	— — —	60 20 15	120 40 30	ns
Second Harmonic Distortion $V_{SS} = -5$ Vdc ($V_{in} = 1.77$ Vdc, RMS Centered @ 0.0 Vdc, $R_L = 10$ k Ω , $f = 1.0$ kHz)	—	5.0	—	0.1	—	%
Bandwidth (Switch ON) (Figure 3) $V_{SS} = -5$ Vdc ($R_L = 1$ k Ω , $20 \text{ Log } \frac{V_{out}}{V_{in}} = -3$ dB, $C_L = 50$ pF, $V_{in} = 5$ V _{p-p})	—	5.0	—	65	—	MHz
Feedthrough Attenuation (Switch OFF) $V_{SS} = -5$ Vdc ($V_{in} = 5$ V _{p-p} , $R_L = 1$ k Ω , $f_{in} = 1.0$ MHz) (Figure 3)	—	5.0	—	-50	—	dB
Channel Separation (Figure 4) $V_{SS} = -5$ Vdc ($V_{in} = 5$ V _{p-p} , $R_L = 1$ k Ω , $f_{in} = 8.0$ MHz) (Switch A ON, Switch B OFF)	—	5.0	—	-50	—	dB
Crosstalk, Control Input to Signal Output (Figure 5) $V_{SS} = -5$ Vdc ($R_1 = 1$ k Ω , $R_L = 10$ k Ω , Control $t_{TLH} = t_{THL} = 20$ ns)	—	5.0	—	300	—	mV _{p-p}

*The formulas given are for the typical characteristics only at 25°C.
#Data labelled "Typ" is not to be used for design purposes but is intended as an indication of the IC's potential performance.

This device contains protection circuitry to guard against damage due to high static voltages or electric fields. However, precautions must be taken to avoid applications of any voltage higher than maximum rated voltages to this high-impedance circuit. For proper operation, V_{in} and V_{out} should be constrained to the range $V_{SS} \leq (V_{in} \text{ or } V_{out}) \leq V_{DD}$.
Unused inputs must always be tied to an appropriate logic voltage level (e.g., either V_{SS} or V_{DD}). Unused outputs must be left open.

PIN ASSIGNMENT

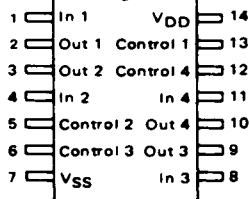

MC14066B

TEST CIRCUITS

FIGURE 1 — ΔV ACROSS SWITCH

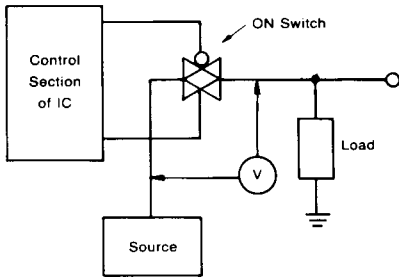

FIGURE 3 — BANDWIDTH AND FEEDTHROUGH ATTENUATION

$V_C = V_{DD}$ for Bandwidth Test
 $V_C = V_{SS}$ for Feedthrough Test

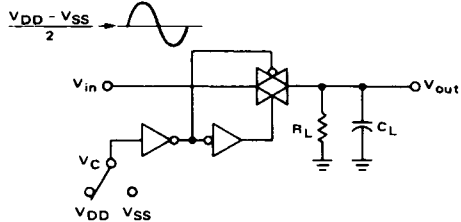

FIGURE 5 — CROSSTALK, CONTROL TO OUTPUT

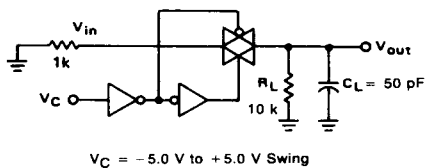

FIGURE 2 — TURN-ON DELAY TIME TEST CIRCUIT AND WAVEFORMS

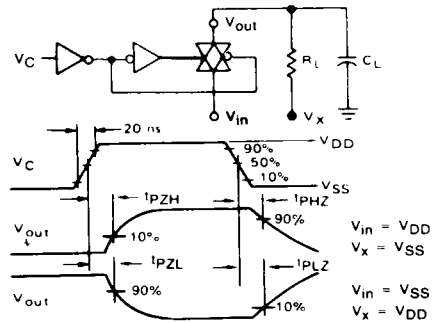

FIGURE 4 — CHANNEL SEPARATION

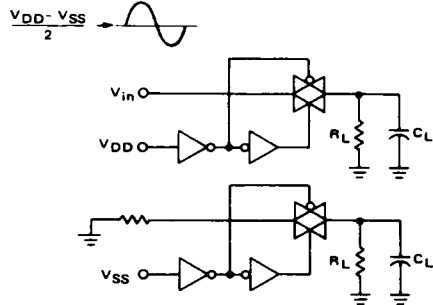
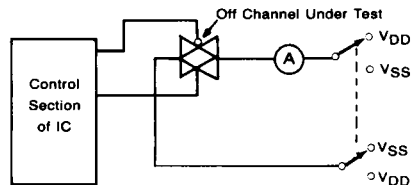
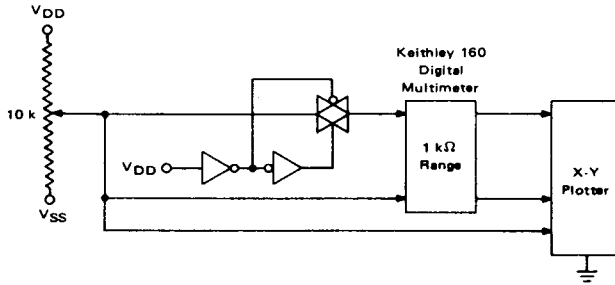

FIGURE 6 — OFF CHANNEL LEAKAGE



MC14066B

FIGURE 7 – CHANNEL RESISTANCE (R_{ON}) TEST CIRCUIT



TYPICAL RESISTANCE CHARACTERISTICS

FIGURE 8 – $V_{DD} = 7.5 \text{ V}$, $V_{SS} = -7.5 \text{ V}$

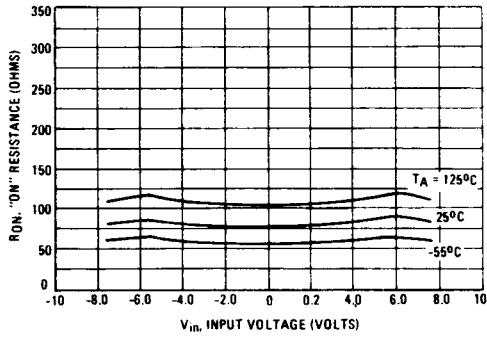

FIGURE 9 – $V_{DD} = 5.0 \text{ V}$, $V_{SS} = -5.0 \text{ V}$

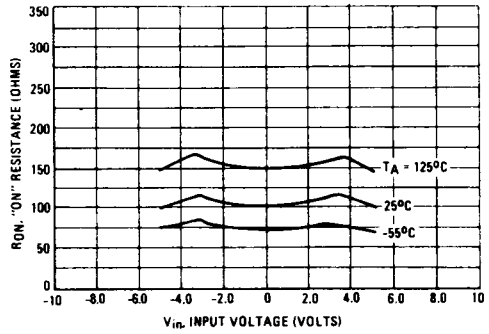

FIGURE 10 – $V_{DD} = 2.5 \text{ V}$, $V_{SS} = -2.5 \text{ V}$

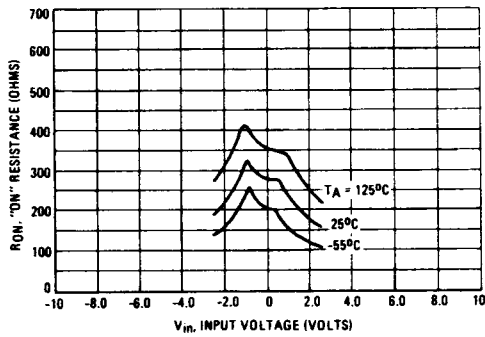
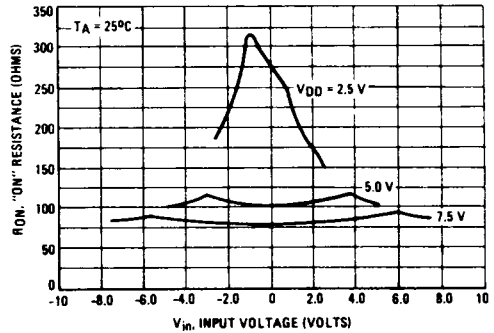

FIGURE 11 – COMPARISON AT 25°C , $V_{DD} = -V_{SS}$



MC14066B

APPLICATIONS INFORMATION

Figure A illustrates use of the Analog Switch. The 0-to-5 volt digital control signal is used to directly control a 5 volt peak-to-peak analog signal.

The digital control logic levels are determined by V_{DD} and V_{SS} . The V_{DD} voltage is the logic high voltage; the V_{SS} voltage is logic low. For the example, $V_{DD} = +5\text{ V} = \text{logic high}$ at the control inputs; $V_{SS} = \text{GND} = 0\text{ V} = \text{logic low}$.

The maximum analog signal level is determined by V_{DD} and V_{SS} . The analog voltage must not swing higher than V_{DD} or lower than V_{SS} .

The example shows a 5 volt peak-to-peak signal which allows no margin at either peak. If voltage transients above V_{DD} and/or below V_{SS} are anticipated on the analog channels, external diodes (D_x) are recommended as shown in Figure B. These diodes should be small signal types able to absorb the maximum anticipated current surges during clipping.

The *absolute* maximum potential difference between V_{DD} and V_{SS} is 18.0 volts. Most parameters are specified up to 15 volts which is the *recommended* maximum difference between V_{DD} and V_{SS} .

FIGURE A — APPLICATION EXAMPLE

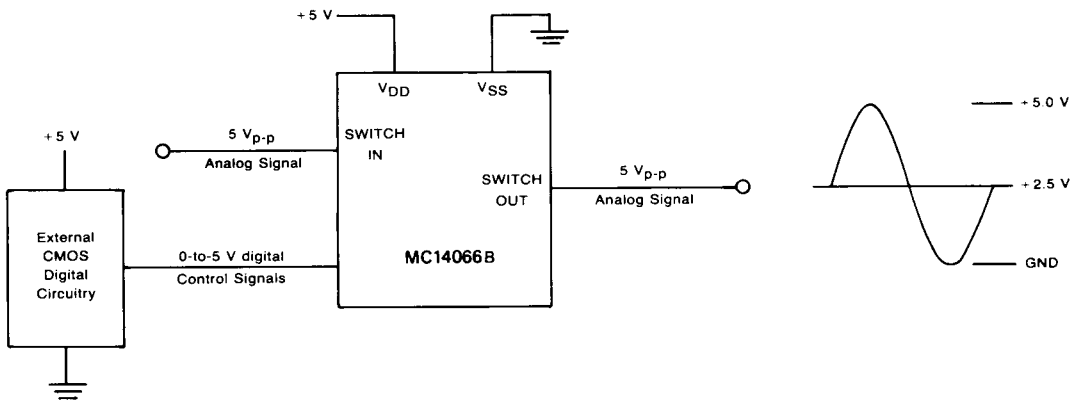
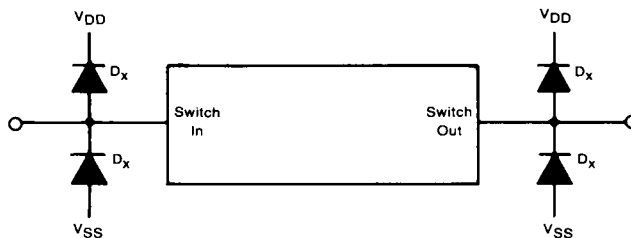

FIGURE B — EXTERNAL GERMANIUM OR SCHOTTKY CLIPPING DIODES



PACKAGE DIMENSIONS

T-90-20

The standard package availability for each device is indicated on the front page of the individual data sheets. Dimensions for the packages are given in this chapter. Surface mount packages may be special ordered by specifying the following suffixes: "D" (narrow SOIC), "DW" (wide SOIC), or "FN" (PLCC). For example, to order a quad NOR gate, use MC14001BD.

14-PIN PACKAGE

**CERAMIC PACKAGE
CASE 632-08**

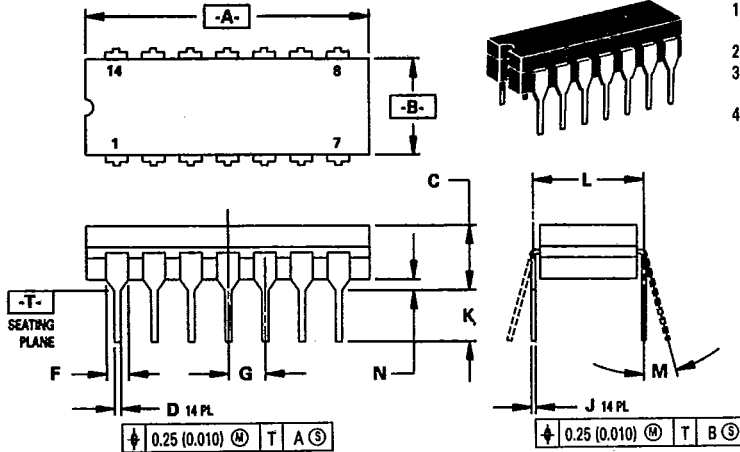

- NOTES:
1. DIMENSIONING AND TOLERANCING PER ANSI Y14.5M, 1982.
 2. CONTROLLING DIMENSION: INCH.
 3. DIMENSION L TO CENTER OF LEAD WHEN FORMED PARALLEL.
 4. DIM F MAY NARROW TO 0.76 (0.030) WHERE THE LEAD ENTERS THE CERAMIC BODY.

DIM	MILLIMETERS		INCHES	
	MIN	MAX	MIN	MAX
A	19.05	19.94	0.750	0.785
B	6.23	7.11	0.245	0.280
C	3.94	5.08	0.155	0.200
D	0.39	0.50	0.015	0.020
F	1.40	1.65	0.055	0.065
G	2.54 BSC		0.100 BSC	
J	0.21	0.38	0.008	0.015
K	3.18	4.31	0.125	0.170
L	7.62 BSC		0.300 BSC	
M	0°	15°	0°	15°
N	0.51	1.01	0.020	0.040

**PLASTIC PACKAGE
CASE 646-06**

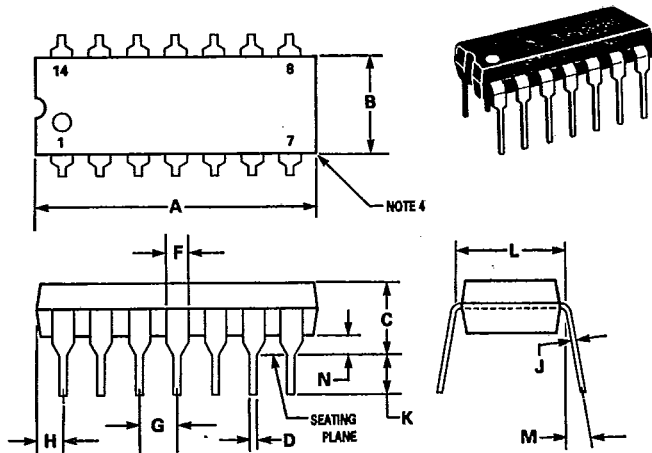

- NOTES:
1. LEADS WITHIN 0.13 mm (0.005) RADIUS OF TRUE POSITION AT SEATING PLANE AT MAXIMUM MATERIAL CONDITION.
 2. DIMENSION "L" TO CENTER OF LEADS WHEN FORMED PARALLEL.
 3. DIMENSION "B" DOES NOT INCLUDE MOLD FLASH.
 4. ROUNDED CORNERS OPTIONAL.

DIM	MILLIMETERS		INCHES	
	MIN	MAX	MIN	MAX
A	18.16	19.56	0.715	0.770
B	6.10	6.60	0.240	0.260
C	3.69	4.69	0.145	0.185
D	0.38	0.53	0.015	0.021
F	1.02	1.78	0.040	0.070
G	2.54 BSC		0.100 BSC	
H	1.32	2.41	0.052	0.095
J	0.20	0.38	0.008	0.015
K	2.92	3.43	0.115	0.135
L	7.62 BSC		0.300 BSC	
M	0°	10°	0°	10°
N	0.39	1.01	0.015	0.039

9

PACKAGE DIMENSIONS (Continued)

14-PIN PACKAGE

SOIC PACKAGE
CASE 751A-02
D SUFFIX

NOTES:

1. DIMENSIONS A AND B ARE DATUMS AND T IS A DATUM SURFACE.
2. DIMENSIONING AND TOLERANCING PER ANSI Y14.5M, 1982.
3. CONTROLLING DIMENSION: MILLIMETER.
4. DIMENSION A AND B DO NOT INCLUDE MOLD PROTRUSION.
5. MAXIMUM MOLD PROTRUSION 0.15 (0.006) PER SIDE.

DIM	MILLIMETERS		INCHES	
	MIN	MAX	MIN	MAX
A	8.55	8.75	0.337	0.344
B	3.80	4.00	0.150	0.157
C	1.35	1.75	0.054	0.068
D	0.35	0.49	0.014	0.019
F	0.40	1.25	0.016	0.049
G	1.27 BSC		0.050 BSC	
J	0.19	0.25	0.008	0.009
K	0.10	0.25	0.004	0.009
M	0°	7°	0°	7°
P	5.80	6.20	0.229	0.244
R	0.25	0.50	0.010	0.019

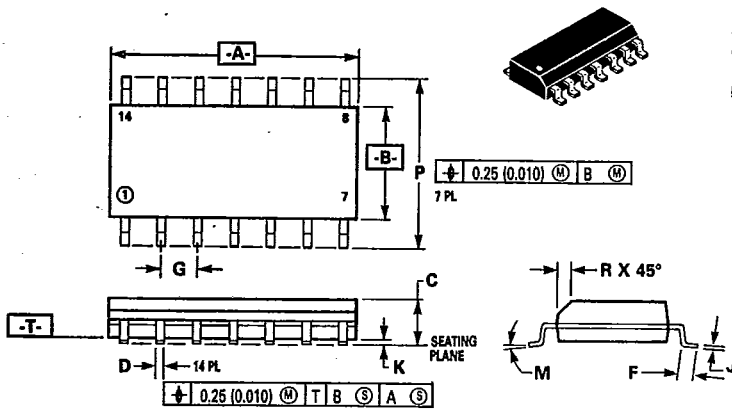

PACKAGE DIMENSIONS (Continued)

16-PIN PACKAGE

CERAMIC PACKAGE
CASE 620-09

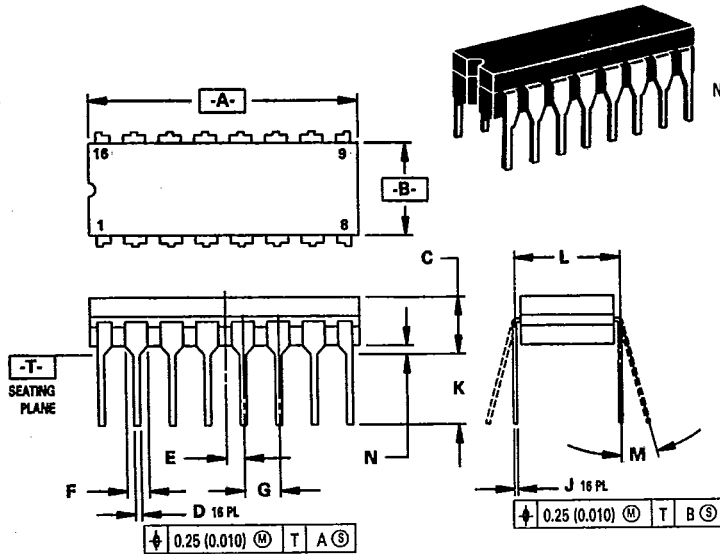

- NOTES:
1. DIMENSIONING AND TOLERANCING PER ANSI Y14.5M, 1982.
 2. CONTROLLING DIMENSION: INCH.
 3. DIMENSION L TO CENTER OF LEAD WHEN FORMED PARALLEL.
 4. DIM F MAY NARROW TO 0.76 (0.030) WHERE THE LEAD ENTERS THE CERAMIC BODY.

DIM	MILLIMETERS		INCHES	
	MIN	MAX	MIN	MAX
A	19.05	19.55	0.750	0.770
B	6.10	7.36	0.240	0.290
C	—	4.19	—	0.165
D	0.39	0.53	0.015	0.021
E	1.27 BSC		0.050 BSC	
F	1.40	1.77	0.055	0.070
G	2.54 BSC		0.100 BSC	
J	0.23	0.27	0.009	0.011
K	—	5.08	—	0.200
L	7.62 BSC		0.300 BSC	
M	0°	15°	0°	15°
N	0.39	0.88	0.015	0.035

PLASTIC PACKAGE
CASE 648-06

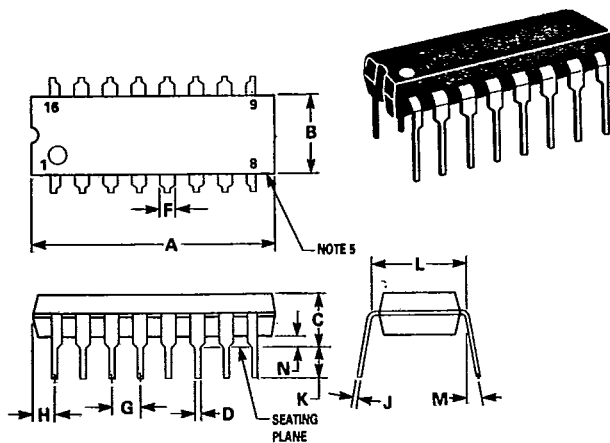

- NOTES:
1. LEADS WITHIN 0.13 mm (0.005) RADIUS OF TRUE POSITION AT SEATING PLANE AT MAXIMUM MATERIAL CONDITION.
 2. DIMENSION "L" TO CENTER OF LEADS WHEN FORMED PARALLEL.
 3. DIMENSION "B" DOES NOT INCLUDE MOLD FLASH.
 4. "F" DIMENSION IS FOR FULL LEADS.
 5. ROUNDED CORNERS OPTIONAL.

DIM	MILLIMETERS		INCHES	
	MIN	MAX	MIN	MAX
A	18.80	21.34	0.740	0.840
B	6.10	6.60	0.240	0.260
C	3.69	4.69	0.145	0.185
D	0.38	0.53	0.015	0.021
F	1.02	1.78	0.040	0.070
G	2.54 BSC		0.100 BSC	
H	0.38	2.41	0.015	0.095
J	0.20	0.38	0.008	0.015
K	2.92	3.43	0.115	0.135
L	7.62 BSC		0.300 BSC	
M	0°	10°	0°	10°
N	0.39	1.01	0.015	0.040

PACKAGE DIMENSIONS (Continued)

16-PIN PACKAGE

SOIC PACKAGE
CASE 751B-03
D SUFFIX

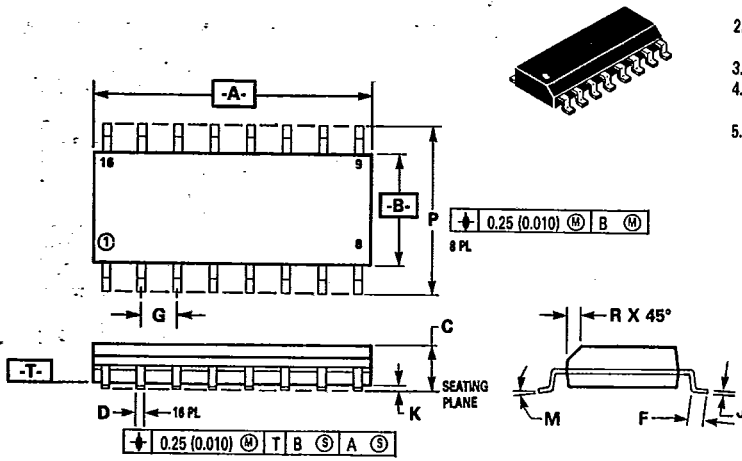

NOTES:

1. DIMENSIONS A AND B ARE DATUMS AND T IS A DATUM SURFACE.
2. DIMENSIONING AND TOLERANCING PER ANSI Y14.5M, 1982.
3. CONTROLLING DIMENSION: MILLIMETER.
4. DIMENSION A AND B DO NOT INCLUDE MOLD PROTRUSION.
5. MAXIMUM MOLD PROTRUSION 0.15 (0.006) PER SIDE.

DIM	MILLIMETERS		INCHES	
	MIN	MAX	MIN	MAX
A	9.80	10.00	0.386	0.393
B	3.80	4.00	0.150	0.157
C	1.35	1.75	0.054	0.068
D	0.35	0.49	0.014	0.019
F	0.40	1.25	0.016	0.049
G	1.27 BSC		0.050 BSC	
J	0.19	0.25	0.008	0.009
K	0.10	0.25	0.004	0.009
M	0°	7°	0°	7°
P	5.80	6.20	0.229	0.244
R	0.25	0.50	0.010	0.019

SOIC PACKAGE
CASE 751G-01
DW SUFFIX

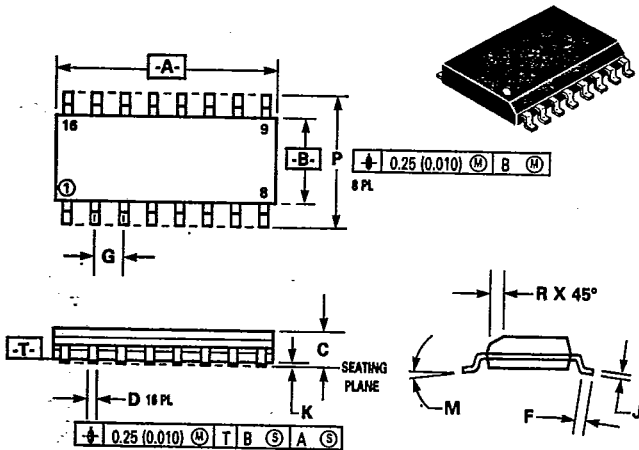

NOTES:

1. DIMENSIONS A AND B ARE DATUMS AND T IS A DATUM SURFACE.
2. DIMENSIONING AND TOLERANCING PER ANSI Y14.5M, 1982.
3. CONTROLLING DIMENSION: MILLIMETER.
4. DIMENSION A AND B DO NOT INCLUDE MOLD PROTRUSION.
5. MAXIMUM MOLD PROTRUSION 0.15 (0.006) PER SIDE.

DIM	MILLIMETERS		INCHES	
	MIN	MAX	MIN	MAX
A	10.15	10.45	0.400	0.411
B	7.40	7.60	0.292	0.299
C	2.35	2.65	0.093	0.104
D	0.35	0.49	0.014	0.019
F	0.50	0.90	0.020	0.035
G	1.27 BSC		0.050 BSC	
J	0.25	0.32	0.010	0.012
K	0.10	0.25	0.004	0.009
M	0°	7°	0°	7°
P	10.05	10.55	0.395	0.415
	0.25	0.75	0.010	0.029

PACKAGE DIMENSIONS (Continued)

18-PIN PACKAGE

PLASTIC PACKAGE
CASE 707-02

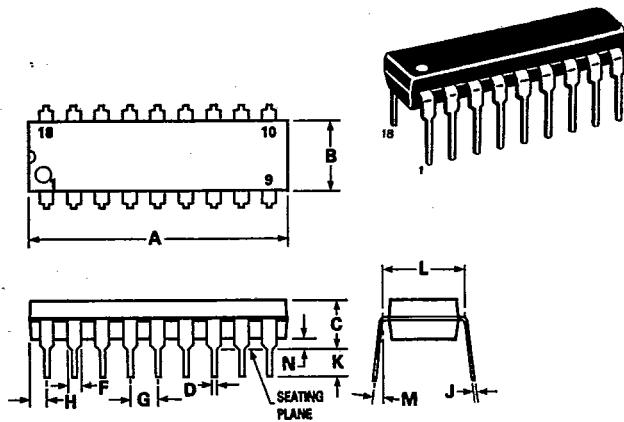

NOTES:

1. POSITIONAL TOLERANCE OF LEADS (D), SHALL BE WITHIN 0.25mm(0.010) AT MAXIMUM MATERIAL CONDITION, IN RELATION TO SEATING PLANE AND EACH OTHER.
2. DIMENSION L TO CENTER OF LEADS WHEN FORMED PARALLEL.
3. DIMENSION B DOES NOT INCLUDE MOLD FLASH.

DIM	MILLIMETERS		INCHES	
	MIN	MAX	MIN	MAX
A	22.22	23.24	0.875	0.915
B	6.10	6.60	0.240	0.260
C	3.56	4.57	0.140	0.180
D	0.36	0.56	0.014	0.022
F	1.27	1.78	0.050	0.070
G	2.54 BSC		0.100 BSC	
H	1.02	1.52	0.040	0.060
J	0.20	0.30	0.008	0.012
K	2.92	3.43	0.115	0.135
L	7.62 BSC		0.300 BSC	
M	0°	15°	0°	15°
N	0.51	1.02	0.020	0.040

CERAMIC PACKAGE
CASE 726-04

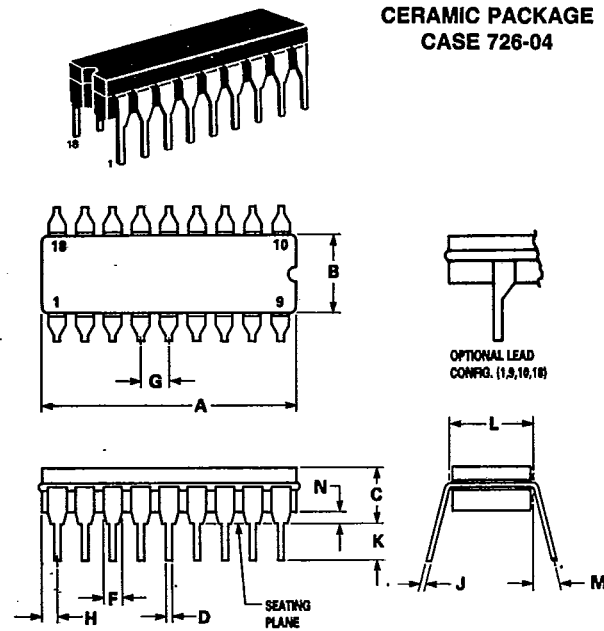

NOTES:

1. LEADS, TRUE POSITIONED WITHIN 0.25 mm (0.010) DIA. AT SEATING PLANE, AT MAXIMUM MATERIAL CONDITION.
2. DIM "L" TO CENTER OF LEADS WHEN FORMED PARALLEL.
3. DIM "A" & "B" INCLUDES MENISCUS.
4. "F" DIMENSION IS FOR FULL LEADS. "HALF" LEADS ARE OPTIONAL AT LEAD POSITIONS 1, 9, 10, AND 18.

DIM	MILLIMETERS		INCHES	
	MIN	MAX	MIN	MAX
A	22.35	23.11	0.880	0.910
B	6.10	7.49	0.240	0.295
C	—	5.08	—	0.200
D	0.38	0.53	0.015	0.021
F	1.40	1.78	0.055	0.070
G	2.54 BSC		0.100 BSC	
H	0.51	1.14	0.020	0.045
J	0.20	0.30	0.008	0.012
K	3.18	4.32	0.125	0.170
L	7.62 BSC		0.300 BSC	
M	0°	15°	0°	15°
N	0.51	1.02	0.020	0.040

9

PACKAGE DIMENSIONS (Continued)

24-PIN PACKAGE

CERAMIC PACKAGE
CASE 623-05

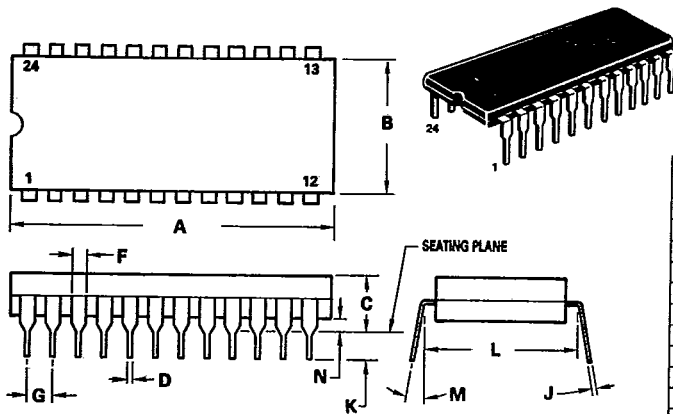

- NOTES:
1. DIM "L" TO CENTER OF LEADS WHEN FORMED PARALLEL.
 2. LEADS WITHIN 0.13 mm (0.005) RADIUS OF TRUE POSITION AT SEATING PLANE AT MAXIMUM MATERIAL CONDITION. (WHEN FORMED PARALLEL).

DIM	MILLIMETERS		INCHES	
	MIN	MAX	MIN	MAX
A	31.24	32.77	1.230	1.290
B	12.70	15.49	0.500	0.610
C	4.06	5.59	0.160	0.220
D	0.41	0.51	0.016	0.020
F	1.27	1.52	0.050	0.060
G	2.54 BSC		0.100 BSC	
J	0.20	0.30	0.008	0.012
K	3.18	4.06	0.125	0.160
L	15.24 BSC		0.600 BSC	
M	0°	15°	0°	15°
N	0.51	1.27	0.020	0.050

PLASTIC PACKAGE
CASE 709-02

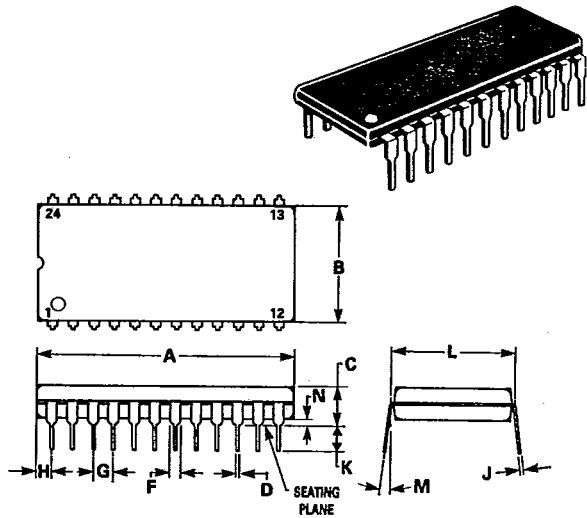

- NOTES:
1. POSITIONAL TOLERANCE OF LEADS (D), SHALL BE WITHIN 0.25 mm (0.010) AT MAXIMUM MATERIAL CONDITION, IN RELATION TO SEATING PLANE AND EACH OTHER.
 2. DIMENSION L TO CENTER OF LEADS WHEN FORMED PARALLEL.
 3. DIMENSION B DOES NOT INCLUDE MOLD FLASH.

DIM	MILLIMETERS		INCHES	
	MIN	MAX	MIN	MAX
A	31.37	32.13	1.235	1.265
B	13.72	14.22	0.540	0.560
C	3.94	5.08	0.155	0.200
D	0.36	0.56	0.014	0.022
F	1.02	1.52	0.040	0.060
G	2.54 BSC		0.100 BSC	
H	1.65	2.03	0.065	0.080
J	0.20	0.38	0.008	0.015
K	2.92	3.43	0.115	0.135
L	15.24 BSC		0.600 BSC	
M	0°	15°	0°	15°
N	0.51	1.02	0.020	0.040