

8097JF/8397JF/8797JF COMMERCIAL/EXPRESS HMOS MICROCONTROLLER

8797JF: an 8097JF with 16 Kbytes of On-Chip EPROM
8397JF: an 8097JF with 16 Kbytes of On-Chip ROM

- 232 Byte Register File
- 256 Bytes XRAM for Code
- 10-Bit A/D Converter with S/H
- Five 8-Bit I/O Ports
- 20 Interrupt Sources
- Pulse-Width Modulated Output
- ROM/EPROM Lock
- Run-Time Programmable EPROM (OTP)
- Extended Temperature Available
- High Speed I/O Subsystem
- Full Duplex Serial Port
- Dedicated Baud Rate Generator
- 6.25 μ s 16 x 16 Multiply
- 6.25 μ s 32/16 Divide
- 16-Bit Watchdog Timer
- Four 16-Bit Software Timers
- Two 16-Bit Counter/Timers
- Extended Burn-In Available

The MCS 96 microcontroller family of 16-bit microcontrollers consists of many members, all of which are designed for high-speed control functions. The MCS-96 family members produced using Intel's HMOS-III process are described in this data sheet.

The CPU supports bit, byte, and word operations. Thirty-two bit double-words are supported for a subset of the instruction set. With a 12 MHz input frequency the 8097JF can do a 16-bit addition in 1.0 μ s and a 16 x 16-bit multiply or 32/16 divide in 6.25 μ s. Instruction execution times average 1 to 2 μ s in typical applications.

Four high-speed trigger inputs are provided to record the times at which external events occur. Six high-speed pulse generator outputs are provided to trigger external events at preset times. The high-speed output unit can simultaneously perform software timer functions. Up to four 16-bit software timers can be in operation at once.

The on-chip A/D converter includes a Sample and Hold, and converts up to 8 multiplexed analog input channels to 10-bit digital values. With a 12 MHz crystal, each conversion takes 22 μ s.

Also provided on-chip are a serial port, a Watchdog Timer and a pulse-width modulated output signal.

With the commercial (standard) temperature option, operational characteristics are guaranteed over the temperature range of 0°C to +70°C. With the extended temperature range option, operational characteristics are guaranteed over the temperature range of -40°C to +85°C. Unless otherwise noted, the specifications are the same for both options.

With the extended burn-in option, the burn-in is dynamic for a minimum time of 160 hours at 125°C with $V_{CC} = 5.5V \pm 0.5V$, following the guidelines in MIL-STD-883, Method 1015.

See the Packaging information for extended temperature and extended burn-in designators.

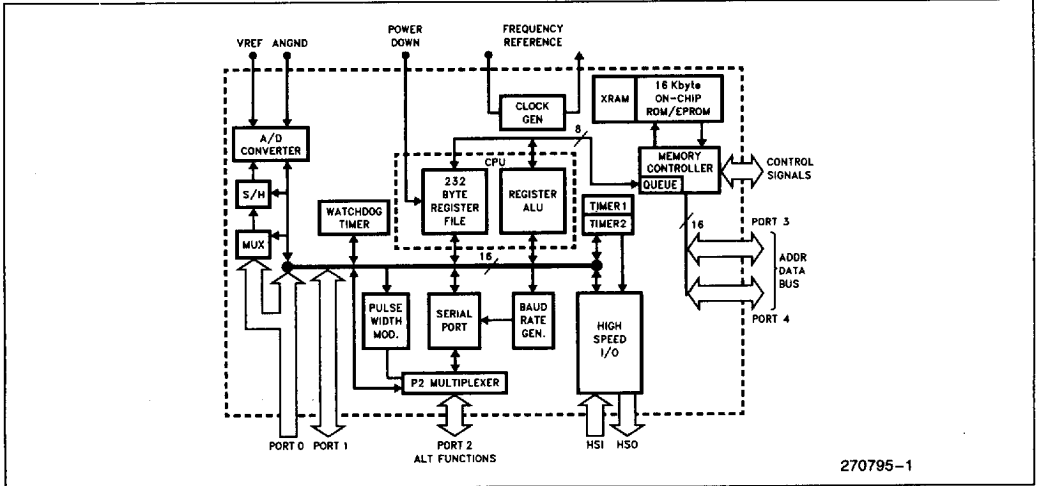

Figure 1. 8X97JF Block Diagram

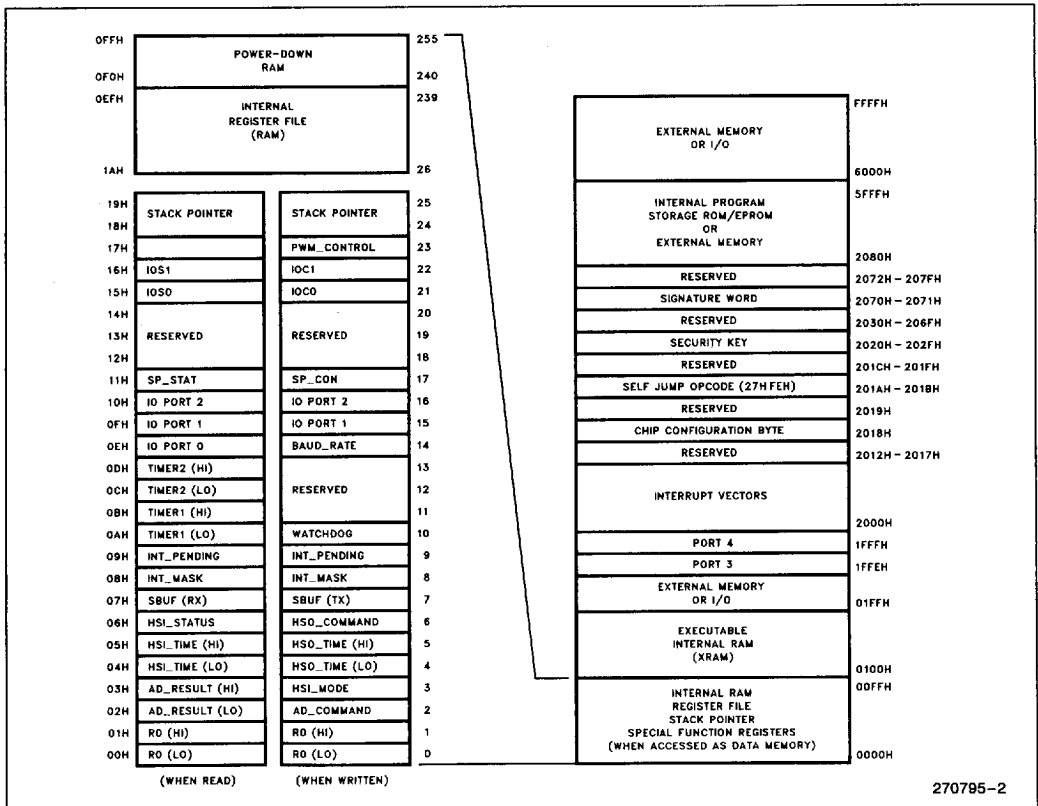

Figure 2. 8X97JF Memory Map

PACKAGING

The 8097JF is available in 64-pin and 68-pin packages, with and without on-chip ROM or EPROM. The 8097JF numbering system is shown in Figure 3. Figures 5–6 show the pinouts for the 64- and 68-pin packages. The 64-pin version is offered in a Shrink-DIP package while the 68-pin versions come in a Plastic Leaded Chip Carrier (PLCC).

8X97JF PACKAGING

Factory Masked ROM		CPU		User Programmable	
				OTP	
68-Pin	64-Pin	68-Pin	64-Pin	68-Pin	64-Pin
8397JF	8397JF	8097JF	8097JF	8797JF	8797JF

Figure 3. The 8097JF Family Nomenclature

Package Designators:

N = PLCC
U = Shrink DIP

Prefix Designators:

T = Extended Temperature
L = Extended Temperature with 160 hrs Burn-in

Package Type	θ_{ja}	θ_{jc}
68L PLCC	37°C/W	13°C/W
64L Shrink DIP	56°C/W	—

Figure 4. 8X97JF Thermal Characteristics

All thermal impedance data is approximate for static air conditions a 1W of power dissipation. Values will change depending on operating conditions and application. See the Intel *Packaging Handbook* (Order Number 240800) for a description of Intel's thermal impedance test methodology.



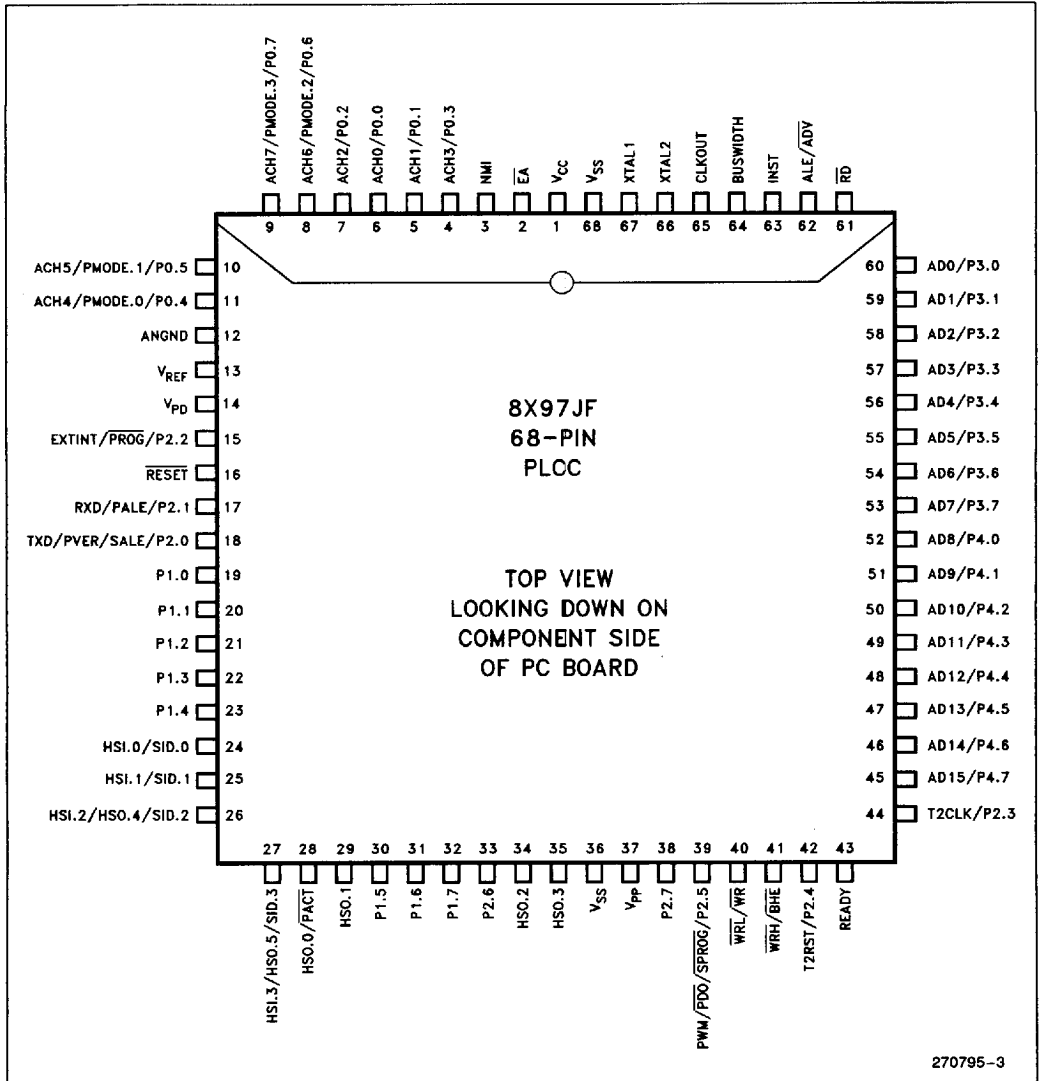

Figure 5. 68-Pin PLCC Package

270795-3

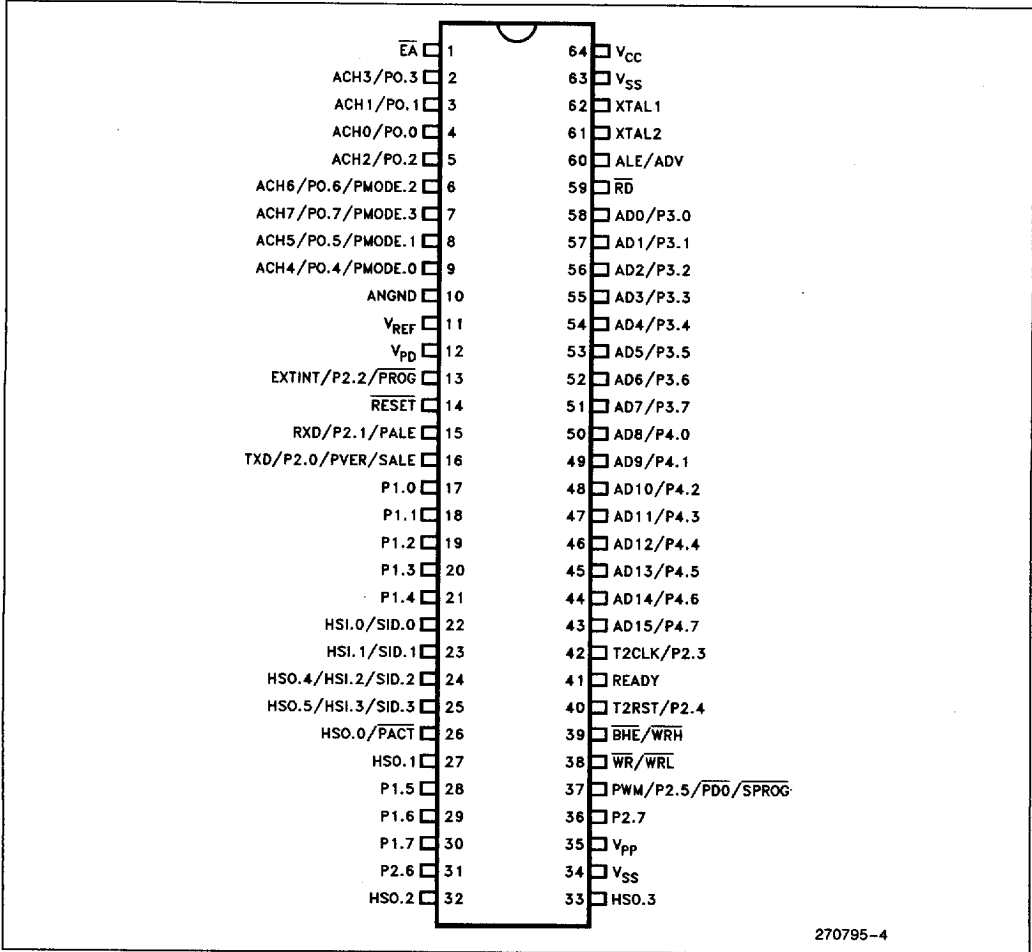

Figure 6. Shrink-DIP Package

4

PIN DESCRIPTIONS

Symbol	Name and Function
V _{CC}	Main supply voltage (5V).
V _{SS}	Digital circuit ground (0V). There are two V _{SS} pins, both of which must be connected.
V _{PD}	RAM standby supply voltage (5V). This voltage must be present during normal operation. In a Power Down condition (i.e., V _{CC} drops to zero), if RESET is activated before V _{CC} drops below spec and V _{PD} continues to be held within spec., the top 16 bytes in the Register File will retain their contents.
V _{REF}	Reference voltage for the A/D converter (5V). V _{REF} is also the supply voltage to the analog portion of the A/D converter and the logic used to read Port 0. Must be connected to use A/D or Port 0.
ANGND	Reference ground for the A/D converter. Must be held at nominally the same potential as V _{SS} .
V _{PP}	Programming voltage for the EPROM devices. It should be +12.75V for programming and will float to 5V otherwise. It should not be above V _{CC} for ROM or CPU devices. This pin must be left floating in the application circuit for EPROM devices.
XTAL1	Input of the oscillator inverter and of the internal clock generator.
XTAL2	Output of the oscillator inverter.
CLKOUT*	Output of the internal clock generator. The frequency of CLKOUT is 1/3 the oscillator frequency. It has a 33% duty cycle.
RESET	Reset input to the chip. Input low for a minimum of 10 XTAL1 cycles to reset the chip. The subsequent low-to-high transition re-synchronizes CLKOUT and commences a 10-state-time RESET sequence.
BUSWIDTH*	Input for bus width selection. If CCR bit 1 is a one, this pin selects the bus width for the bus cycle in progress. If BUSWIDTH is a 1, a 16-bit bus cycle occurs. If BUSWIDTH is a 0 an 8-bit cycle occurs. If CCR bit 1 is a 0, the bus is always an 8-bit bus. If this pin is left unconnected, it will rise to V _{CC} .
NMI*	A positive transition causes a vector to external memory location 0000H.
INST*	Output high during an external memory read indicates the read is an instruction fetch. INST is valid throughout the bus cycle.
EA	Input for memory select (External Access). EA equal to a TTL-high causes memory accesses to locations 2000H through 5FFF to be directed to on-chip ROM/EPROM. EA equal to a TTL-low causes accesses to these locations to be directed to off-chip memory. EA = +12.75V causes the device to enter the Programming Mode.
ALE/ADV	Address Latch Enable or Address Valid output, as selected by the CCR. Both pin options provide a latch to demultiplex the address from the address/data bus. When the pin is ADV, it goes inactive high at the end of the bus cycle. ALE/ADV is activated only during external memory accesses.
RD	Read signal output to external memory. RD is activated only during external memory reads.
WR/WRL	Write and Write Low output to external memory, as selected by the CCR. WR will go low for every external write, while WRL will go low only for external writes where an even byte is being written. WR/WRL is activated only during external memory writes.
BHE/WRH	Bus High Enable or Write High output to external memory, as selected by the CCR. BHE will go low for external writes to the high byte of the data bus. WRH will go low for external writes where an odd byte is being written. BHE/WRH is activated only during external memory writes.

*Not available on Shrink-DIP Package

PIN DESCRIPTIONS (Continued)

Symbol	Name and Function
READY	Ready input to lengthen external memory cycles. If the pin is low prior to the falling edge of CLKOUT, the memory controller goes into a wait mode until the next positive transition of CLKOUT occurs with READY high. When the external memory is not being used, READY has no effect. Internal control of the number of wait states inserted into a bus cycle held not ready is available in the CCR.
HSI	Inputs to High Speed Input Unit. Four HSI pins are available: HSI.0, HSI.1, HSI.2 and HSI.3. Two of them (HSI.2 and HSI.3) are shared with the HSO Unit.
HSO	Outputs from High Speed Output Unit. Six HSO pins are available: HSO.0, HSO.1, HSO.2, HSO.3, HSO.4 and HSO.5. Two of them (HSO.4 and HSO.5) are shared with the HSI Unit.
Port 0	8-bit high impedance input-only port. These pins can be used as digital inputs and/or as analog inputs to the on-chip A/D converter.
Port 1	8-bit quasi-bidirectional I/O port.
Port 2	8-bit multi-functional port. Six of its pins are shared with other functions in the 8096JF, the remaining 2 are quasi-bidirectional. These pins are also used to input and output control signals on EPROM devices in Programming Mode.
Ports 3 and 4	8-bit bidirectional I/O ports with open drain outputs. These pins are shared with the multiplexed address/data bus, which has strong internal pull-ups. Ports 3 and 4 are also used as a command, address and data path by EPROM devices operating in the Programming Mode.
PMODE	Determines the EPROM programming mode.
PACT	A low signal in Auto Programming Mode indicates that programming is in progress. A high signal indicates programming is complete.
PVAL	A low signal in Auto Programming Mode indicates that the device programmed correctly.
SALE	A falling edge in Auto Programming Mode indicates that Ports 3 and 4 contain valid programming address/command information (output from master).
SPROG	A falling edge in Auto Programming Mode indicates that Ports 3 and 4 contain valid programming data (output from master).
SID	Assigns a pin of Ports 3 and 4 to each slave to pass programming verification.
PALE	A falling edge in Slave Programming Mode and Auto Configuration Byte Programming Mode indicates that Ports 3 and 4 contain valid programming address/command information (input to slave).
PROG	A falling edge in Slave Programming Mode indicates that Ports 3 and 4 contain valid programming data (input to slave).
PVER	A high signal in Slave Programming Mode and Auto Configuration Byte Programming Mode indicates the byte programmed correctly.
PVAL	A high signal in Slave Programming Mode indicates the device programmed correctly.
PDO	A low signal in Slave Programming Mode indicates that the PROG pulse was applied for longer than allowed.

4

ELECTRICAL CHARACTERISTICS ABSOLUTE MAXIMUM RATINGS*

Ambient Temperature Under Bias	-55°C to +125°C
Storage Temperature	-60°C to +150°C
Voltage from E \bar{A} or V _{pp} to V _{SS} or ANGND	-0.3V to +13.0V
Voltage from Any Other Pin to V _{SS} or ANGND	-0.3V to +7.0V ⁽¹⁾
Average Output Current from Any Pin	10 mA
Power Dissipation ⁽²⁾	1.5W

NOTES:

1. This includes V_{pp} and E \bar{A} on ROM and CPU only devices.
2. Power dissipation is based on package heat transfer characteristics, not device power consumption.

OPERATING CONDITIONS

(All characteristics specified in this data sheet apply to these operating conditions unless otherwise noted.)

Symbol	Parameter	Min	Max	Units
T _A	Ambient Temperature Under Bias Commercial Temp.	0	+70	°C
T _A	Ambient Temperature Under Bias Extended Temp.	-40	+85	°C
V _{CC}	Digital Supply Voltage	4.50	5.50	V
V _{REF}	Analog Supply Voltage	4.50	5.50	V
F _{OSC}	Oscillator Frequency	6.0	12	MHz
V _{PD}	Power-Down Supply Voltage	4.50	5.50	V

NOTE:

ANGND and V_{SS} should be nominally at the same potential.

DC CHARACTERISTICS

Symbol	Parameter	Min	Max	Units	Test Conditions
I _{CC}	V _{CC} Supply Current Commercial Temp.		300	mA	All Outputs Disconnected
I _{CC}	V _{CC} Supply Current Extended Temp.		330	mA	
I _{CC}	V _{CC} Supply Current (T _A ≥ 70°C)		245	mA	
I _{PD}	V _{PD} Supply Current		1	mA	Normal operation and Power-Down
I _{REF}	V _{REF} Supply Current Commercial Temp.		8	mA	
I _{REF}	V _{REF} Supply Current Extended Temp.		10	mA	
V _{IL}	Input Low Voltage	-0.3	+0.8	V	
V _{IL1}	Input Low Voltage, <u>RESET</u> Commercial Temp.	-0.3	+0.8	V	
V _{IL1}	Input Low Voltage, <u>RESET</u> Extended Temp.	-0.3	+0.7	V	

DC CHARACTERISTICS (Continued)

Symbol	Parameter	Min	Max	Units	Test Conditions
V _{IH}	Input High Voltage (Except RESET, NMI, XTAL1)	2.0	V _{CC} + 0.5	V	
V _{IH1}	Input High Voltage, RESET Rising	2.4	V _{CC} + 0.5	V	
V _{IH2}	Input High Voltage, RESET Falling (Hysteresis)	2.1	V _{CC} + 0.5	V	
V _{IH3}	Input High Voltage, NMI, XTAL1 Commercial Temp.	2.2	V _{CC} + 0.5	V	
V _{IH3}	Input High Voltage, NMI, XTAL1 Extended Temp.	2.3	V _{CC} + 0.5	V	
I _{LI}	Input Leakage Current to each pin of HSI, P3, P4, and to P2.1		± 10	μA	V _{IN} = 0 to V _{CC}
I _{LI1}	DC Input Leakage Current to each pin of P0		+ 3	μA	V _{IN} = 0 to V _{CC}
I _{IH}	Input High Current to \overline{EA}		100	μA	V _{IH} = 2.4V
I _{IL}	Input Low Current to each pin of P1, and to P2.6, P2.7 Commercial Temp.		- 125	μA	V _{IL} = 0.45V
I _{IL}	Input Low Current to each pin of P1, and to P2.6, P2.7 Extended Temp.		- 150	μA	V _{IL} = 0.45V
I _{IL1}	Input Low Current to RESET	- 0.25	- 2	mA	V _{IL} = 0.45V
I _{IL2}	Input Low Current P2.2, P2.3, P2.4, READY, BUSWIDTH		- 50	μA	V _{IL} = 0.45V
V _{OL}	Output Low Voltage on Quasi-Bidirectional port pins and P3, P4 when used as ports		0.45	V	I _{OL} = 0.8 mA (Note 1)
V _{OL1}	Output Low Voltage on Quasi-Bidirectional port pins and P3, P4 when used as ports		0.75	V	I _{OL} = 2.0 mA (Notes 1, 2, 3)
V _{OL2}	Output Low Voltage on Standard Output pins, RESET and Bus/Control Pins		0.45	V	I _{OL} = 2.0 mA (Notes 1, 2, 3)
V _{OH}	Output High Voltage on Quasi-Bidirectional pins	2.4		V	I _{OH} = - 20 μA (Note 1)
V _{OH1}	Output High Voltage on Standard Output pins and Bus/Control pins	2.4		V	I _{OH} = - 200 μA (Note 1)
I _{OH3}	Output High Current on RESET	- 50		μA	V _{OH} = 2.4V
C _S	Pin Capacitance (Any Pin to V _{SS})		10	pF	F _{TEST} = 1.0 MHz

NOTES:

1. Quasi-bidirectional pins include those on P1, for P2.6 and P2.7. Standard Output Pins include TXD, RXD (Mode 0 only), PWM and HSO pins. Bus/Control pins include CLKOUT, ALE, BHE, RD, WR, INST and AD0-15.
2. Maximum current per pin must be externally limited to the following values if V_{OL} is held above 0.45V.
 - I_{OL} on quasi-bidirectional pins and Ports 3 and 4 when used as ports: 4.0 mA
 - I_{OL} on standard output pins and RESET: 8.0 mA
 - I_{OL} on Bus/Control pins: 2.0 mA
3. During normal (non-transient) operation the following limits apply:
 - Total I_{OL} on Port 1 must not exceed 8.0 mA.
 - Total I_{OL} on P2.0, P2.6, RESET and all HSO pins must not exceed 15 mA.
 - Total I_{OL} on Port 3 must not exceed 10 mA.
 - Total I_{OL} on P2.5, P2.7, and Port 4 must not exceed 20 mA.

PRELIMINARY

■ 4826175 0144671 T57 ■

4-53

AC CHARACTERISTICS

Test Conditions: Load Capacitance on Output Pins = 80 pF

TIMING REQUIREMENTS (The system must meet these specifications to work with the 8X97JF)

Symbol	Parameter	Min	Max	Units
$T_{CLYX}^{(3)}$	READY Hold after CLKOUT Edge	0 ⁽¹⁾		ns
T_{LLYV}	End of ALE/ \overline{ADV} to READY Valid		$2 T_{OSC} - 70$	ns
T_{LLYH}	End of ALE/ \overline{ADV} to READY High	$2 T_{OSC} + 40$	$4 T_{OSC} - 80$	ns
T_{YLYH}	Non-Ready Time		1000	ns
$T_{AVDV}^{(2)}$	Address Valid to Input Data Valid		$5 T_{OSC} - 120^{(4)}$	ns
T_{RLDV}	\overline{RD} Active to Input Data Valid		$3 T_{OSC} - 100^{(4)}$	ns
T_{RHDX}	Data Hold after \overline{RD} Inactive	0		ns
T_{RHDZ}	\overline{RD} Inactive to Input Data Float	0	$T_{OSC} - 25$	ns
$T_{AVGV}^{(2,3)}$	Address Valid to BUSWIDTH Valid		$2 T_{OSC} - 125$	ns
$T_{LLGX}^{(3)}$	BUSWIDTH Hold after ALE/ \overline{ADV} Low	$T_{OSC} + 40$		ns
$T_{LLGV}^{(3)}$	ALE/ \overline{ADV} Low to BUSWIDTH Valid		$T_{OSC} - 100$	ns
T_{RLPV}	Reset Low to Ports Valid		$10 T_{OSC}$	ns

NOTES:

1. If the 64-pin device is being used then this timing can be generated by assuming that the CLKOUT falling edge has occurred at $2 T_{OSC} + 55$ (TLLCH(max) + TCHCL(max)) after the falling edge of ALE.
2. The term "Address Valid" applies to AD0-15, BFE and INST.
3. Pins not bonded out on 64-pin devices.
4. If wait states are used, add $3 T_{OSC} * N$ where N = number of wait states.

TIMING RESPONSES (8X97JF devices meet these specs.)

Symbol	Parameter	Min	Max	Units
F _{XTAL}	Oscillator Frequency	6.0	12.0	MHz
T _{OSC}	Oscillator Period	83	166	ns
T _{OHCH} ⁽³⁾	XTAL1 Rising Edge to Clockout Rising Edge	0	120	ns
T _{CHCH} ⁽³⁾	CLKOUT Period	3 T _{OSC} ⁽²⁾	3 T _{OSC} ⁽²⁾	ns
T _{CHCL} ⁽³⁾	CLKOUT High Time	T _{OSC} - 35	T _{OSC} + 10	ns
T _{CLLH} ⁽³⁾	CLKOUT Low to ALE High	- 30	+ 15	ns
T _{LLCH} ⁽³⁾	ALE/ADV Low to CLKOUT High	T _{OSC} - 25	T _{OSC} + 45	ns
T _{LHLL}	ALE/ADV High Time	T _{OSC} - 30	T _{OSC} + 35 ⁽⁴⁾	ns
T _{AVLL} ⁽⁵⁾	Address Setup to End of ALE/ADV	T _{OSC} - 50		ns
T _{RLAZ} ⁽⁶⁾	\overline{RD} or \overline{WR} Low to Address Float Commercial Temp.	Typ. = 0	10	ns
T _{RLAZ} ⁽⁶⁾	\overline{RD} or \overline{WR} Low to Address Float Extended Temp.		25	ns
T _{LLRL}	End of ALE/ADV to \overline{RD} or \overline{WR} Active	T _{OSC} - 40		ns
T _{LLAX} ⁽⁶⁾	Address Hold after End of ALE/ADV	T _{OSC} - 40		ns
T _{WLWH}	\overline{WR} Pulse Width	3 T _{OSC} - 35 ⁽¹⁾		ns
T _{QVWH}	Output Data Valid to End of $\overline{WR}/\overline{WRL}/\overline{WRH}$	3 T _{OSC} - 60 ⁽¹⁾		ns
T _{WHQX}	Output Data Hold after $\overline{WR}/\overline{WRL}/\overline{WRH}$	T _{OSC} - 50		ns
T _{WHLH}	End of $\overline{WR}/\overline{WRL}/\overline{WRH}$ to ALE/ADV High	T _{OSC} - 75		ns
T _{RLRH}	\overline{RD} Pulse Width	3 T _{OSC} - 30 ⁽¹⁾		ns
T _{RHLH}	End of \overline{RD} to ALE/ADV High	T _{OSC} - 45		ns
T _{CLL} ⁽³⁾	CLOCKOUT Low to ALE/ADV Low	T _{OSC} - 40	T _{OSC} + 35	ns
T _{RHBX} ⁽³⁾	\overline{RD} High to INST, \overline{BHE} , AD8-15 Inactive	T _{OSC} - 25	T _{OSC} + 30	ns
T _{WHBX} ⁽³⁾	\overline{WR} High to INST, \overline{BHE} , AD8-15 Inactive	T _{OSC} - 50	T _{OSC} + 100	ns
T _{HLHH}	\overline{WRL} , \overline{WRH} Low to \overline{WRL} , \overline{WRH} High	2 T _{OSC} - 35	2 T _{OSC} + 40	ns
T _{LLHL}	ALE/ADV Low to \overline{WRL} , \overline{WRH} Low	2 T _{OSC} - 30	2 T _{OSC} + 55	ns
T _{QVHL}	Output Data Valid to \overline{WRL} , \overline{WRH} Low	T _{OSC} - 60		ns

NOTES:

1. If more than one wait state is desired, add 3 T_{OSC} for each additional wait state.
2. CLKOUT is directly generated as a divide by 3 of the oscillator. The period will be 3 T_{OSC} ± 10 ns if T_{OSC} is constant and the rise and fall times on XTAL1 are less than 10 ns.
3. CLKOUT, INST and \overline{BHE} pins not bonded out on 64-lead package.
4. Max spec applies only to ALE. Min spec applies to both ALE and \overline{ADV} .
5. The term "Address Valid" applies to AD0-15, \overline{BHE} and INST.
6. The term "Address" in this specification applies to AD0-7 for 8-bit cycles, and AD0-15 for 16-bit cycles.

4

PRELIMINARY

■ 4826175 0144673 82T ■

4-55

WAVEFORM— T_{RLPV}

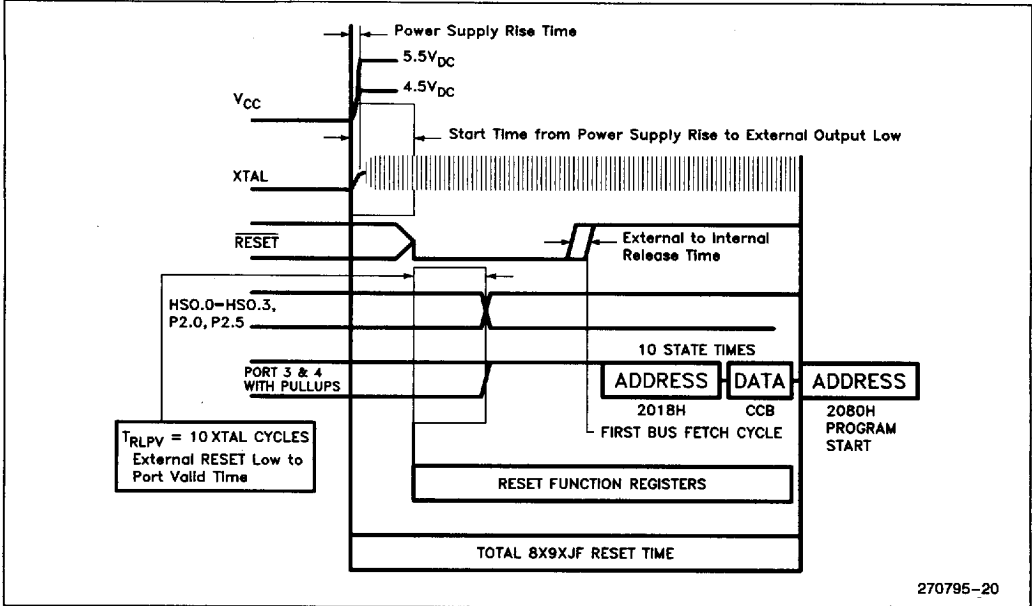

270795-20

EXTERNAL CLOCK DRIVE

Symbol	Parameter	Min	Max	Units
$1/T_{OLOL}$	Oscillator Frequency	6	12	MHz
T_{OH0X}	High Time	25		ns
T_{OLOX}	Low Time	30		ns
T_{OLOH}	Rise Time		15	ns
T_{OHOL}	Fall Time		15	ns

EXTERNAL CLOCK DRIVE WAVEFORMS

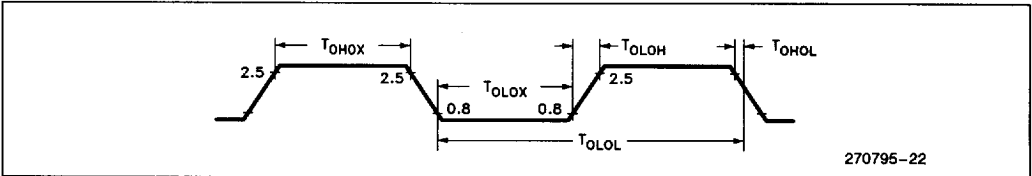

270795-22

An external oscillator may encounter as much as a 100 pF load at XTAL1 when it starts-up. This is due to interaction between the amplifier and its feedback capacitance. Once the external signal meets the V_{IL} and V_{IH} specifications the capacitance will not exceed 20 pF.

EXTERNAL CRYSTAL CONNECTIONS

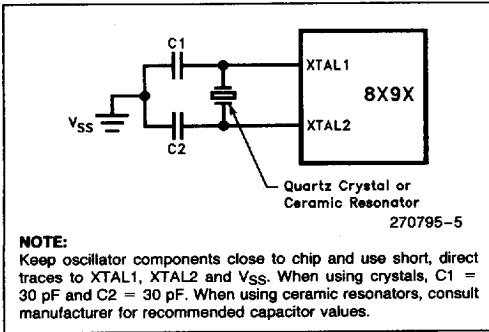

EXTERNAL CLOCK CONNECTIONS

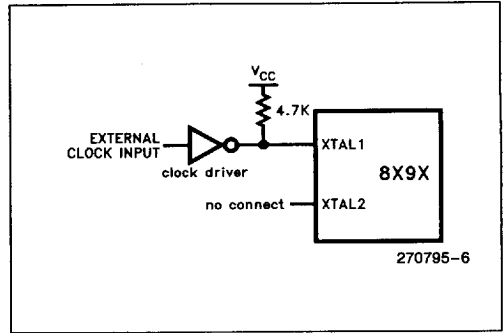

AC TESTING INPUT, OUTPUT WAVEFORMS

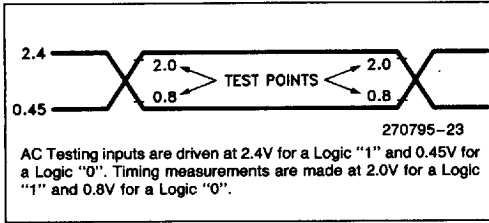

FLOAT WAVEFORMS

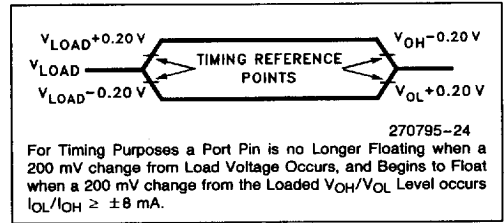

MINIMUM HARDWARE CONFIGURATION CIRCUITS

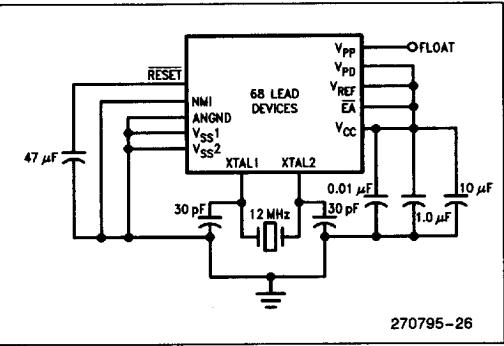
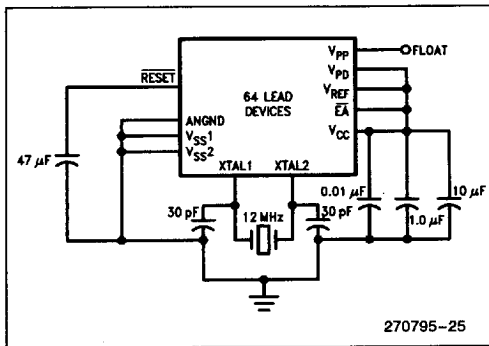

A/D CONVERTER SPECIFICATIONS

The absolute conversion accuracy is dependent on the accuracy and stability of V_{REF} .

See the MCS-96 A/D Converter Quick Reference for definitions of A/D Converter terms.

Parameter	Typical*	Minimum	Maximum	Units**	Notes
Resolution		1024 10	1024 10	Levels Bits	
Absolute Error		0	±4	LSBs	
Full Scale Error	-0.5 ± 0.5			LSBs	
Zero Offset Error	±0.5			LSBs	
Non-Linearity		0	±4	LSBs	
Differential Non-Linearity		> -1	+2	LSBs	
Channel-to-Channel Matching		0	±1	LSBs	
Repeatability	±0.25			LSBs	
Temperature Coefficients:					
Offset	0.009			LSB/°C	
Full Scale	0.009			LSB/°C	
Differential Non-Linearity	0.009			LSB/°C	
Off Isolation		-60		dB	1, 3
Feedthrough	-60			dB	1
V_{CC} Power Supply Rejection	-60			dB	1
Input Series Resistance		1K	5K	Ω	4
DC Input Leakage		0	3.0	μA	
Sample Delay		3 $T_{OSC} - 50$	3 $T_{OSC} + 50$	ns	2
Sample Time		12 $T_{OSC} - 50$	12 $T_{OSC} + 50$	ns	
Sampling Capacitor			2	pF	

NOTES:

* These values are expected for most devices at 25°C.

** An "LSB", as used here, is defined in the MCS-96 A/D Converter Quick Reference and has a value of approximately 5 mV.

1. DC to 100 KHz.
2. For starting the A/D with an HSO Command.
3. Multiplexer Break-Before-Make Guaranteed.
4. Resistance from device pin, through internal MUX, to sample capacitor.

OTP EPROM SPECIFICATIONS
EPROM PROGRAMMING OPERATING CONDITIONS

Symbol	Parameter	Min	Max	Units
T_A	Ambient Temperature during Programming	20	30	C
$V_{CC}, V_{PD}, V_{REF}^{(1)}$	Supply Voltages during Programming	4.5	5.5	V
V_{EA}	Programming Mode Supply Voltage	9.0	13.0	V ⁽²⁾
V_{PP}	EPROM Programming Supply Voltage	12.50	13.0	V ⁽²⁾
$V_{SS}, ANGND^{(3)}$	Digital and Analog Ground	0	0	V
$F_{OSC}^{(1)}$	Oscillator Frequency during Auto and Slave Programming	6.0	6.0	MHz
$F_{OSC}^{(2)}$	Oscillator Frequency during Run-Time Programming	6.0	12.0	MHz

NOTES:

- V_{CC}, V_{PD} and V_{REF} should nominally be at the same voltage during programming.
- V_{EA} and V_{PP} must never exceed the maximum voltage for any amount of time or the device may be damaged.
- V_{SS} and $ANGND$ should nominally be at the same voltage (0V) during programming.

AC EPROM PROGRAMMING CHARACTERISTICS

Symbol	Parameter	Min	Max	Units
T_{AVLL}	ADDRESS/COMMAND Valid to PALE Low	0		T_{OSC}
T_{LLAX}	ADDRESS/COMMAND Hold After PALE Low	80		T_{OSC}
T_{DVPL}	Output Data Setup Before \overline{PROG} Low	0		T_{OSC}
T_{PLDX}	Data Hold After \overline{PROG} Falling	80		T_{OSC}
T_{LLLH}	PALE Pulse Width	180		T_{OSC}
T_{PLPH}	\overline{PROG} Pulse Width	$250 T_{OSC}$	$100 \mu s + 144 T_{OSC}$	
T_{LHPL}	PALE High to \overline{PROG} Low	250		T_{OSC}
T_{PHLL}	\overline{PROG} High to Next PALE Low	600		T_{OSC}
T_{PHDX}	Data Hold After \overline{PROG} High	30		T_{OSC}
T_{PHVV}	\overline{PROG} High to $PVER/\overline{PD0}$ Valid	500		T_{OSC}
T_{LLVH}	PALE Low to $PVER/\overline{PD0}$ High	100		T_{OSC}
T_{PLDV}	\overline{PROG} Low to VERIFICATION/DUMP Data Valid	100		T_{OSC}
T_{SHLL}	RESET High to First PALE Low (not shown)	2000		T_{OSC}

DC EPROM PROGRAMMING CHARACTERISTICS

Symbol	Parameter	Min	Max	Units
I_{PP}	V_{PP} Supply Current (Whenever Programming)		100	mA

4

8X97JF ERRATA

Devices covered by this data sheet (see Revision History) have the following errata.

1. INDEXED, 3 OPERAND MULTIPLY

The displacement portion of an indexed, three operand (byte or word) multiply may not be in the range of 200H thru 17FFH inclusive. If you must use these displacements, execute an indexed, two operand multiply and a move if necessary.

2. 8X97JF HIGH SPEED INPUTS

The High Speed Input (HSI) has three deviations from the specifications. Note that "events" are defined as one or more pin transitions. "Entries" are defined as the recording of one or more events.

- A. The resolution is nine states instead of eight states. Events occurring on the same pin more frequently than once every nine state times may be lost.
- B. A mismatch between the nine state HSI resolution and the eight state hardware timer causes one time-tag value to be skipped every nine timer counts. Events may receive a time tag one count later than expected.
- C. If the FIFO and Holding Register are empty, the first event will transfer into the Holding Register, leaving the FIFO empty again. The next event that occurs will be the first event loaded into the empty FIFO. If the first two events into any **empty** FIFO (not counting the Holding Register) occur coincident with each other, both are recorded as one entry with one time-tag. If the second event occurs within 9 states after the first, the events will be entered separately with time-tags at least one count apart. If the second event enters the FIFO coincident with the "skipped" time-tag situation (see B above) the time-tags will be at least two counts apart.

3. RESERVED LOCATION 2019H

The 1990 Architectural Overview recommends that reserved location 2019H be filled with hex value FFH. The recommendation is now to fill 2019H with hex value 20H.

4. RESERVED LOCATION 201CH

Reading reserved location 201CH, either internally or externally, will return "201C" as data.

5. SERIAL PORT SECTION

Serial Port Flags—Reading SP_STAT may not clear the TI or RI flag if that flag was set within two state times prior to the read. In addition, the parity error bit (RPE/RB8) may not be correct if it is read within two state times after RI is set. Use the following code to replace ORB sp_image, SP_STAT.

```
SP_READ:  LDB TEMP, SP_STAT
           ORB SP_IMAGE, TEMP
           JBS TEMP,5,SP_READ; if TI
           is set then read again
           JBS TEMP,6,SP_READ; if RI
           is set then read again
           ANDB SP_IMAGE,#7FH; clear
           false RB8/RPE
           ORB SP_IMAGE, TEMP; load
           correct RB8/RPE
```