

TOSHIBA Bi-CMOS INTEGRATED CIRCUIT SILICON MONOLITHIC

**T B 1 2 3 8 N****PAL / NTSC 1CHIP (IF + VCD PROCESSOR) IC**

TB1238N is the IF & Video processing IC for PAL/NTSC color TV system. This IC demodulates PAL/NTSC PIF, SIF and composite video signal to R/G/B primary colors and Audio signals. This IC can constitute Multi-Color System by combined with TA1275AZ (SECAM Processor).

TB1238N has the analog R/G/B interface, therefore it is easy to make up PIP system by using this IC.

Because of the built-in video and audio switch, TB1238N can deal with an external channel without extra switch.

TB1238N has an I<sup>2</sup>C BUS interface. Various controls (Brightness, Color etc.) can be done via two bus lines.

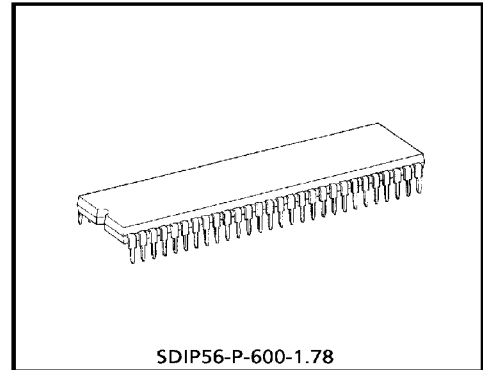

SDIP56-P-600-1.78

Weight : 5.55g (Typ.)

961001EBA1

- TOSHIBA is continually working to improve the quality and the reliability of its products. Nevertheless, semiconductor devices in general can malfunction or fail due to their inherent electrical sensitivity and vulnerability to physical stress. It is the responsibility of the buyer, when utilizing TOSHIBA products, to observe standards of safety, and to avoid situations in which a malfunction or failure of a TOSHIBA product could cause loss of human life, bodily injury or damage to property. In developing your designs, please ensure that TOSHIBA products are used within specified operating ranges as set forth in the most recent products specifications. Also, please keep in mind the precautions and conditions set forth in the TOSHIBA Semiconductor Reliability Handbook.
- The products described in this document are subject to foreign exchange and foreign trade control laws.
- The information contained herein is presented only as a guide for the applications of our products. No responsibility is assumed by TOSHIBA CORPORATION for any infringements of intellectual property or other rights of the third parties which may result from its use. No license is granted by implication or otherwise under any intellectual property or other rights of TOSHIBA CORPORATION or others.
- The information contained herein is subject to change without notice.

1998-03-12 1/77

**FEATURES**

## IF stage

- Intercarrier Input
- Double Time Constant IF AGC
- Bus Controlled RF AGC
- Bus Controlled PIF VCO
- L-SECAM Demodulation
- PLL SIF Demodulation (For 4.5~6.5MHz multi-SIF, Thank coil-less)

## Video stage

- Built-in Video Switch (2 Inputs / 1 Output)
- Built-in Chroma Trap
- Built-in Y Delay Line
- Black Expansion
- DL Type Sharpness Control

## Chroma stage

- 1 X'tal for Multi-System (3.58MHz / 4.43MHz / M-PAL / N-PAL)
- Built-in 1HDL
- Built-in BPF / TOF
- SECAM R-Y, B-Y Input
- Automatic Color System Detection
- Fsc Continuous Wave Output

## Text stage

- Fast Blanking
- Analog R / G / B Interface
- Cut-Off / Drive Adjustment
- ABCL

## Deflection stage

- Resonator less H-VCO
- Dual Horizontal AFC
- Horizontal Phase Control
- Vertical Phase & Amplitude Control
- H / V Lock Detection
- Sand Castle Pulse Output (HD + VD + Gate Pulse)
- No Vertical Output Mode

## Audio Stage

- Built-in Audio Switch (2 Inputs / 1 Output)
- Built-in Audio Attenuator

BLOCK DIAGRAM

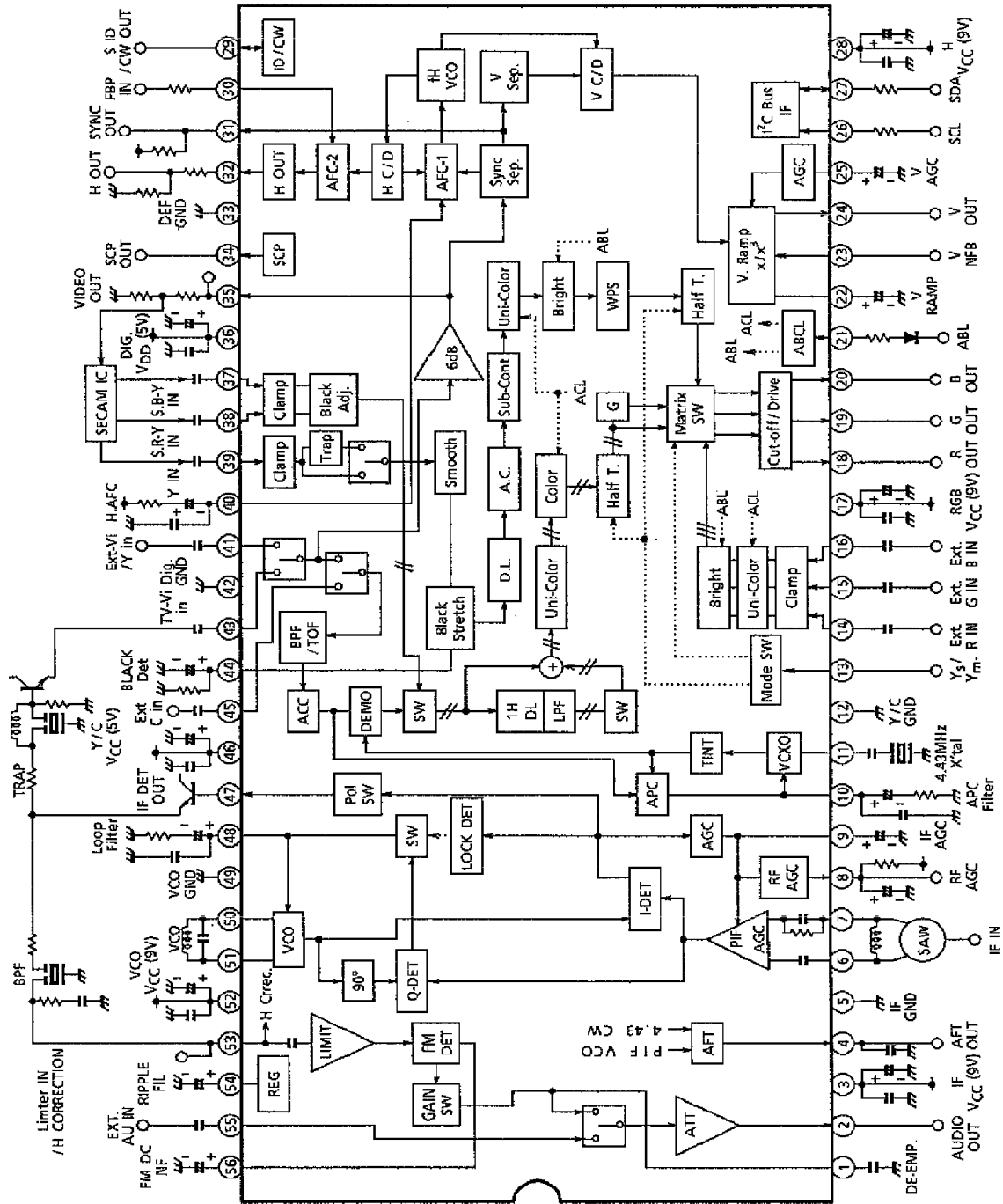

TB1238N - 3

TERMINAL INTERFACE		FUNCTION	INTERFACE CIRCUIT	INPUT / OUTPUT
PIN No.	1 De-Emphasis	<p>The terminal to be connected with capacitor for de-emphasis. 1500pF capacitance realizes <math>75\mu\text{s} / 50\mu\text{s}</math> de-emphasis (Switched by bus). The output impedance is as follows;                      PAL : <math>33\text{k}\Omega</math>                      NTSC : <math>50\text{k}\Omega</math></p>		<p>At PAL  <math>927\text{mVrms}</math></p>
	2 Audio Output	<p>The terminal for audio output. FM Det. signal or the signal inputted from Pin 55 is outputted (Switched by bus). And its amplitude is controlled by bus.</p>		<p>At ATT Max.  <math>927\text{mVrms}</math></p>

PIN No.	PIN NAME	FUNCTION	INTERFACE CIRCUIT	INPUT / OUTPUT
3	IF VCC (9V)	The terminal for VCC of PIF circuit. Supply 9V. In order to prevent leakage through VCC, inserting traps for IF carrier and $f_H$ is recommended.	-	-
4	AFT Output / Self-Adj. Output	The terminal for AFT output and Self-adj. output. AFT voltage, half of RF AGC Voltage, Red signal or Blue signal is outputted (Switched by bus) for self alignment. AFT output impedance is 50Ω (typ).		0.3V~4.7V
5	IF GND	The terminal for GND of PIF circuit. In order to realize good PIF Det. performance for low IF input, separate IF GND wiring from VCO GND (Pin 49) as far as possible.	-	-

TB1238N - 5

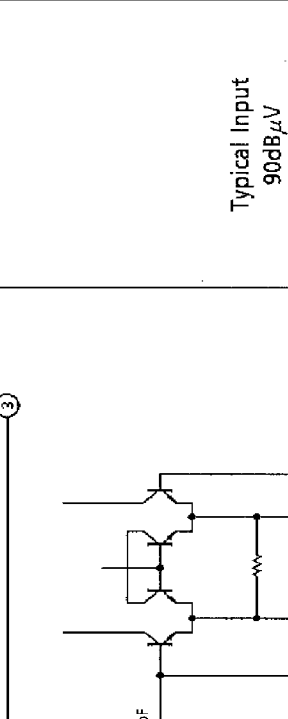
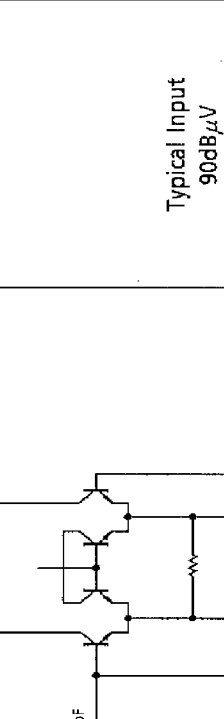
PIN No.	PIN NAME	FUNCTION	INTERFACE CIRCUIT	INPUT/OUTPUT
6	IF Input	The terminal for IF signal input.		Typical Input 90dB $\mu$ V
7	IF Input	Pin 6 & Pin 7 are the both input poles of a differential amplifier.		
8	RF AGC	The terminal for RF AGC output (Open corrector Output). To get rid of noises, connect a capacitor to this terminal.		0V~9V

TB1238N - 6

PIN No.	PIN NAME	FUNCTION	INTERFACE CIRCUIT	INPUT/OUTPUT
9	IF AGC	<p>The terminal to be connected with an IF AGC filter. Peak AGC works n-sync. tip level of PIF Det. signal. For L-SECAM, the capacitor on pin 56 filters for AGC.</p>		2V~8V
10	APC Filter	<p>The terminal to be connected with APC filter for chroma demodulation. This terminal voltage controls the frequency of VCXO.</p>		-

TB1238N - 7

PIN No.	PIN NAME	FUNCTION	INTERFACE CIRCUIT	INPUT/OUTPUT												
11	X'tal	<p>The terminal to be connected with a 4.433619MHz X'tal oscillator.</p> <p>This is the standard of both of 4.43MHz/3.58MHz chroma demodulation and horizontal VCO.</p> <p>MIL : HC-49 / U is recommended.</p>		-												
12	Y/C GND	<p>The terminal for GND of Y/C circuit.</p>	-	-												
13	Y <sub>S</sub> /Y <sub>m</sub>	<p>The terminal for switching of Analog RGB Mode and fast Half tone.</p> <p>On Analog RGB Mode, the signal inputted into Pin 14, 15, 16 are outputted from Pin 18, 19, 20.</p> <p>For Half tone, the S16, D1 of i<sup>2</sup>C BUS SW has to be "1".</p>		<table border="1"> <tr> <td>-----</td> <td>Analog RGB</td> <td>-----</td> <td>2.1V</td> </tr> <tr> <td>-----</td> <td>Half tone</td> <td>-----</td> <td>0.7V</td> </tr> <tr> <td>-----</td> <td>TV</td> <td>-----</td> <td>GND</td> </tr> </table> <p>Hex 16 D1 = 0 Hex 16 D1 = 1</p>	-----	Analog RGB	-----	2.1V	-----	Half tone	-----	0.7V	-----	TV	-----	GND
-----	Analog RGB	-----	2.1V													
-----	Half tone	-----	0.7V													
-----	TV	-----	GND													

TB1238N - 8



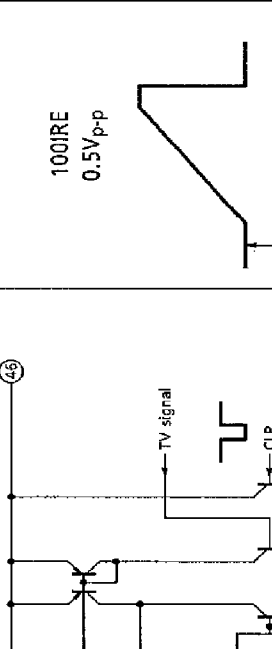
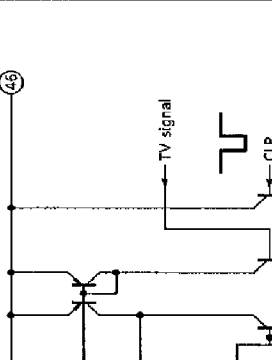
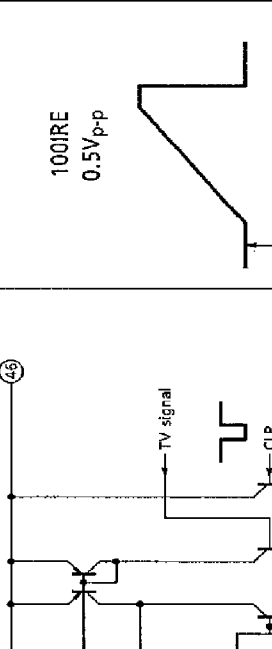
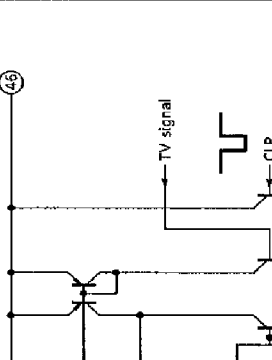
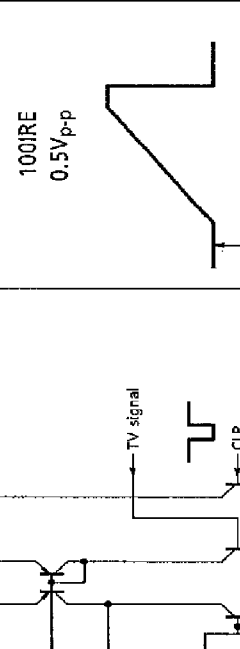
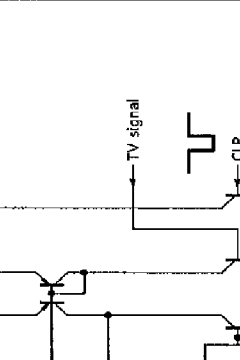
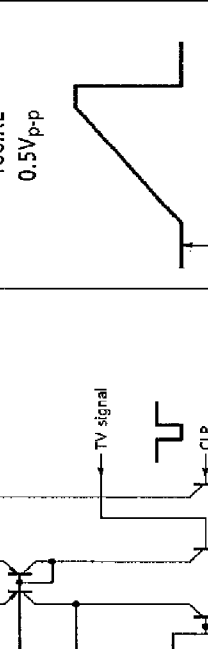
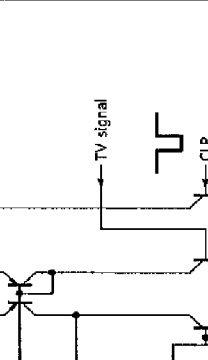
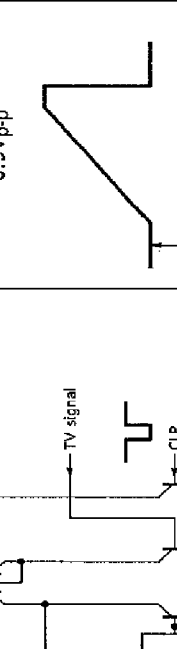
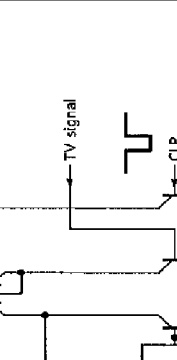

PIN No.	PIN NAME	FUNCTION	INTERFACE CIRCUIT	INPUT / OUTPUT
14	Analog R Input	The terminal for Analog RGB signals input.		
15	Analog G Input	Input signals are clamped by charging / discharging coupling capacitors, therefore input with low impedance.		
16	Analog B Input	100Ω or less is recommended.		
17	RGB VCC (9V)	The terminal for VCC of RGB circuit (TEXT circuit). supply 9V.		
18	R Output	The terminals for R signals output. Because of the limit of output current, set the resistance 2.0kΩ or more to GND.		

TB1238N - 9

PIN No.	PIN NAME	FUNCTION	INTERFACE CIRCUIT	INPUT/OUTPUT
19	G Output	The terminals for G signals output. Because of the limit of output current, set the resistance $2.0k\Omega$ or more to GND.		
20	B Output	The terminals for B signals output. Because of the limit of output current, set the resistance $2.0k\Omega$ or more to GND.		

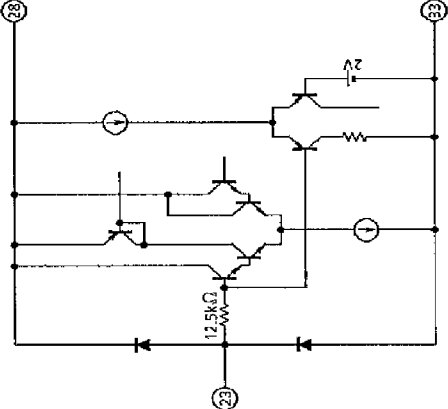
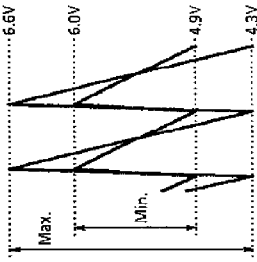
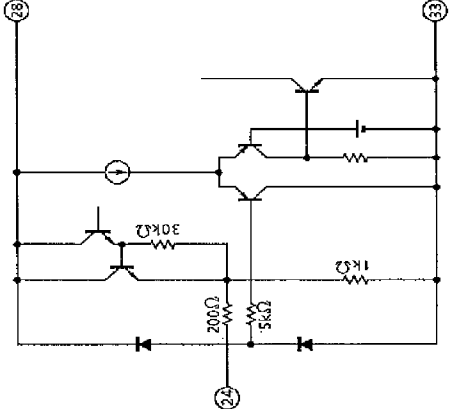
PIN No.	PIN NAME	FUNCTION	INTERFACE CIRCUIT	INPUT/OUTPUT
21	ABCL	<p>The terminal for ABL/ACL control. Control voltage range is 5.5V~6.0V. ABL Gain &amp; ABL start point are selectable by bus.</p>		<p>At Open 6V</p>
22	V.Ramp	<p>The terminal to be connected with a capacitor to make V.Ramp signal. V.Ramp amplitude is kept constant by V.AGC function.</p>		

PIN No.	PIN NAME	FUNCTION	INTERFACE CIRCUIT	INPUT / OUTPUT
23	V.NFB	<p>The terminal for input of V.sawteeth signal feedback. The amplitude of feedback signal is controlled by bus.</p>		
24	V.Output	<p>The terminal for output of Vertical drive signal.</p>		

PIN No.	PIN NAME	FUNCTION	INTERFACE CIRCUIT	INPUT / OUTPUT
25	V.AGC	<p>The terminal to be connected with a capacitor for V.AGC. V.AGC keeps V.Ramp amplitude constant.</p>		-
26	SCL	<p>The terminal for input of I<sup>2</sup>C bus clock.</p>		-

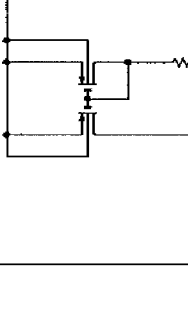
PIN No.	PIN NAME	FUNCTION	INTERFACE CIRCUIT	INPUT / OUTPUT
27	SDA	The terminal for input/output of I <sup>2</sup> C bus data.		-
28	H. VCC (9V)	The terminal for VCC of deflection circuit. Supply 9V. For 4V or more, VCXO oscillates and for 5.5V or more, H OUT signal is outputted. Set the raising time between 4V and 5.5V longer than 1.5ms.	-	

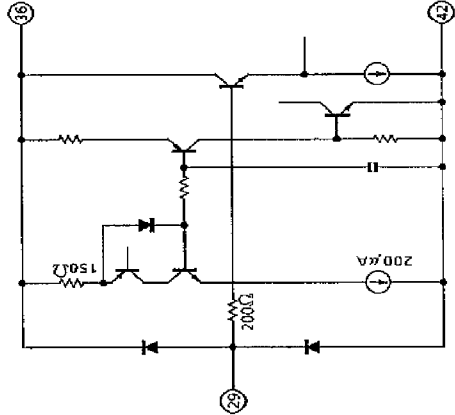
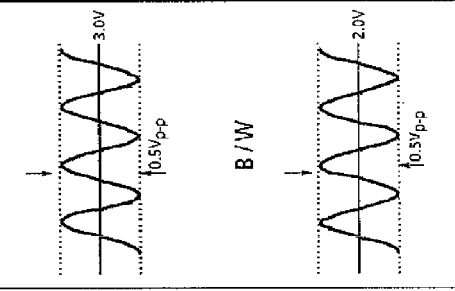
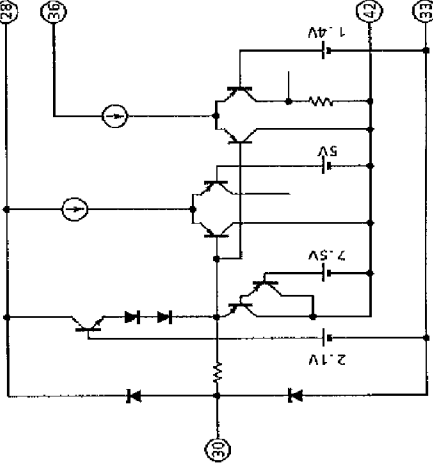
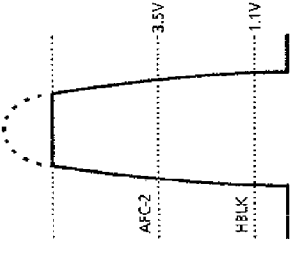
PIN No.	PIN NAME	FUNCTION	INTERFACE CIRCUIT	INPUT / OUTPUT
29	ID In/Output/ Fsc CW Output	<p>The terminal for PAL/NTSC ID output and SECAM ID input. By sinking <math>150\mu\text{A}</math> or more from this terminal, this IC turns to be SECAM mode. By sinking <math>220\sim 380\mu\text{A}</math> from this terminal, this IC gives priority to SECAM mode. And the terminal for chroma sub-carrier frequency, switched by bus (Fixed 4.43MHz / Auto).</p>		
30	FBP Input	<p>The terminal for FBP Input.</p>		

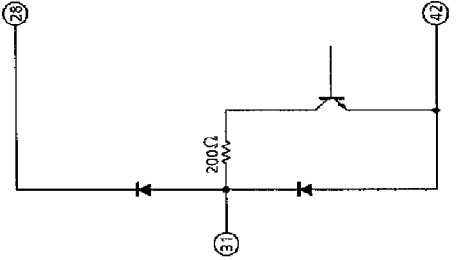
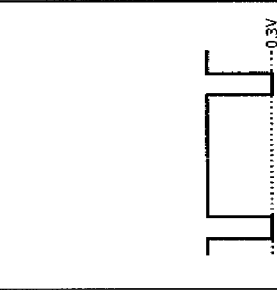
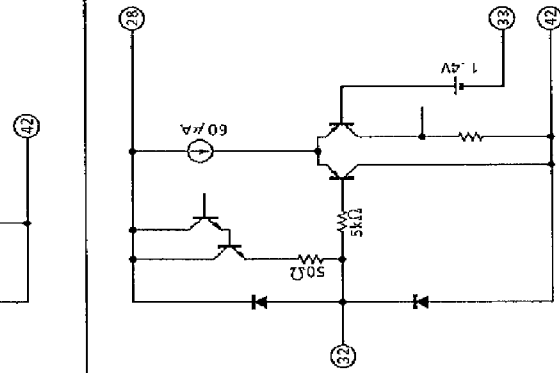
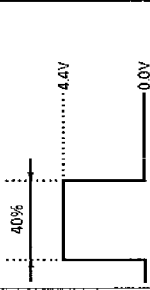
PIN No.	PIN NAME	FUNCTION	INTERFACE CIRCUIT	INPUT / OUTPUT
31	SYNC Output	The terminal for composite sync. output (Open corrector output).		
32	H.Output	The terminal for output of horizontal drive signal.		



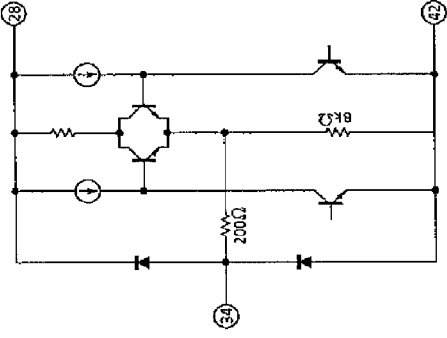
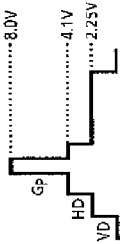
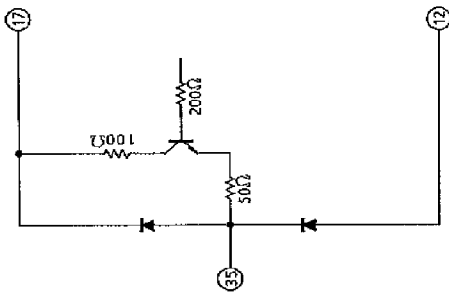

PIN No.	PIN NAME	FUNCTION	INTERFACE CIRCUIT	INPUT/OUTPUT
33	DEF GND	The terminal for GND of deflection circuit.	—	—
34	SCP Output	The terminal for Sand Castle Pulse (VD + HD + Gp) output.		
35	Video SW Output	The terminal for Video Switch output. The signal inputted into Pin 41 or 43 is outputted through 6dB AMP.		2V <sub>p-p</sub>

TB1238N - 17

PIN No.	PIN NAME	FUNCTION	INTERFACE CIRCUIT	INPUT/OUTPUT
36	Dig. VDD (5V)	The Terminal for VDD of digital block. Supply 5V.	—	—
37	SECAM B-Y Input	The terminal for SECAM B-Y/R-Y input. Input signals are clamped by charging / discharging coupling capacitors, therefore input with low impedance.		
38	SECAM R-Y Input	The terminal for SECAM R-Y input. Input signals are clamped by charging / discharging coupling capacitors, therefore input with low impedance.		
39	Y Input	The terminal for Y input. Input signal is clamped by charging / discharging coupling capacitor, therefore input with low impedance. 100Ω or less is recommended. Typical input amplitude is 1.0V <sub>pp</sub> .		

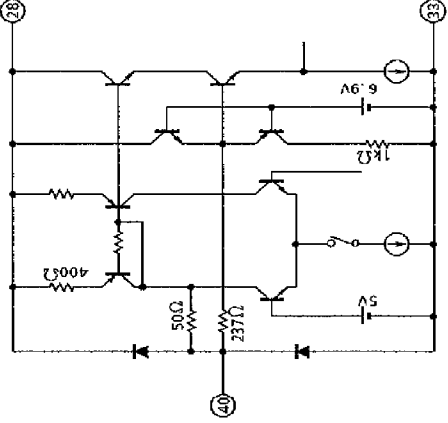
TB1238N - 18

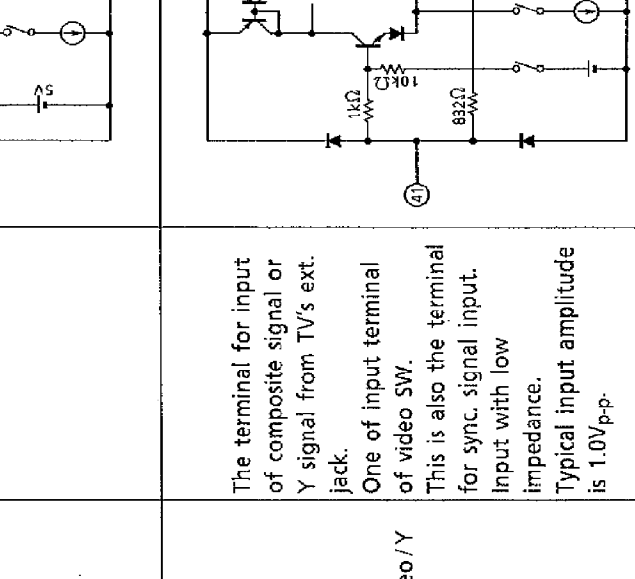
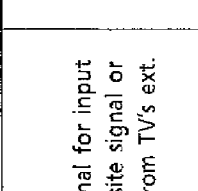
PIN No.	PIN NAME	FUNCTION	INTERFACE CIRCUIT	INPUT / OUTPUT
40	H. AFC	<p>The terminal to be connected with H.AFC filter.</p> <p>This terminal voltage controls H. frequency.</p>		
41	EXT. Video / Y Input	<p>The terminal for input of composite signal or Y signal from TV's ext. jack.</p> <p>One of input terminal of video SW.</p> <p>This is also the terminal for sync. signal input. Input with low impedance.</p> <p>Typical input amplitude is 1.0V<sub>p-p</sub>.</p>		
42	Dig. GND	The terminal for GND of digital block.	-	-

TB1238N - 19

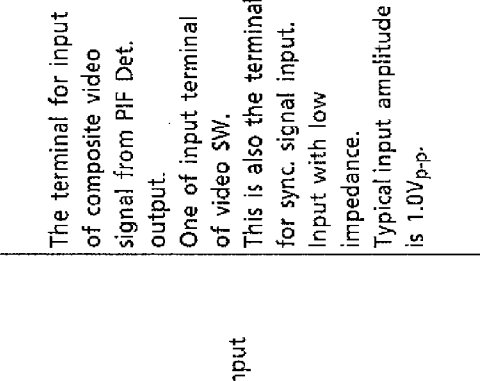
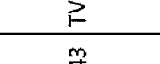
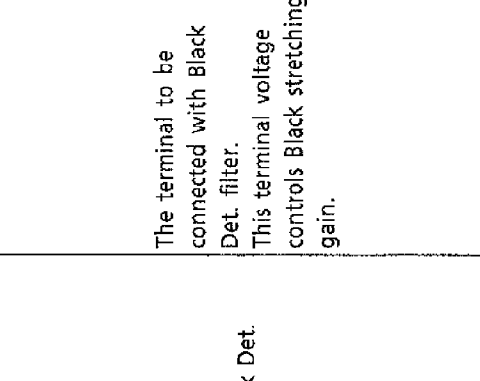
PIN No.	PIN NAME	FUNCTION	INTERFACE CIRCUIT	INPUT / OUTPUT
43	TV Input	<p>The terminal for input of composite video signal from PIF Det. output.</p> <p>One of input terminal of video SW.</p> <p>This is also the terminal for sync. signal input. Input with low impedance.</p> <p>Typical input amplitude is 1.0V<sub>p-p</sub>.</p>		
44	Black Det.	<p>The terminal to be connected with Black Det. filter.</p> <p>This terminal voltage controls Black stretching gain.</p>		-

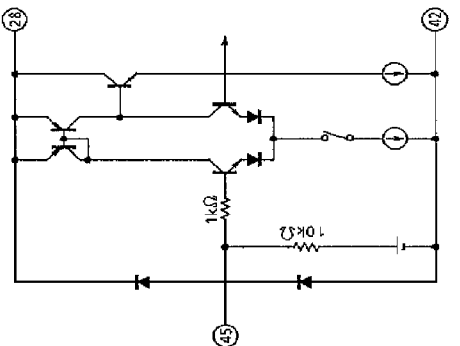
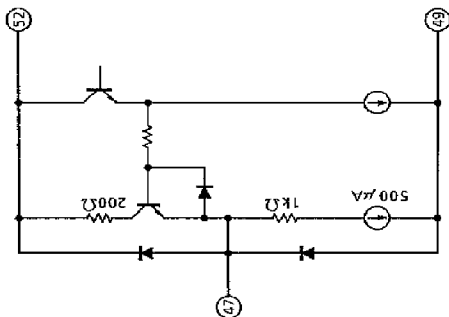
PIN No.	PIN NAME	FUNCTION	INTERFACE CIRCUIT	INPUT / OUTPUT
45	EXT. C Input	The terminal for input of chroma signal from TV's ext. jack. Input through a coupling capacitor.		Burst Amplitude 286mV <sub>p-p</sub>
46	Y/C V <sub>CC</sub> (5V)	The terminal for V <sub>CC</sub> of Y/C circuit. Supply 5V.	—	—
47	IF Det. Output	The terminal for output of composite video signal and SIF signal detected in IF circuit. Typical video output amplitude is 2.2V <sub>p-p</sub> . In order to reduce 920kHz beat, connect a emitter follower to drive audio trap and band-pass-filter.		2V <sub>p-p</sub>

TB1238N - 21

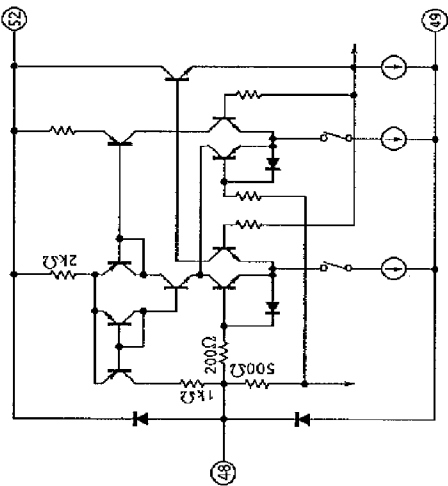
PIN No.	PIN NAME	FUNCTION	INTERFACE CIRCUIT	INPUT / OUTPUT
48	Loop Filter	<p>The terminal to be connected with loop filter for IF PLL.</p> <p>This terminal voltage controls the frequency of IF VCO.</p>		-
49	VCO GND	<p>The terminal for GND of VCO and SIF circuit.</p> <p>In order to realize good PIF Det. performance for low IF input, please separate VCO GND wiring from IF GND (Pin 5) as far as possible.</p>	-	-

TB1238N - 22

PIN No.	PIN NAME	FUNCTION	INTERFACE CIRCUIT	INPUT / OUTPUT
50	VCO	The terminal to be connected with a tank coil for IF VCO.		-
51		IF VCO frequency is controlled by bus. For 27pF ext. capacitance, frequency variable range is $\pm 2\text{MHz}$ .		
52	VCO VCC (9V)	The terminal for VCC of IF VCO and SIF. Supply 9V. In order to prevent leakage through VCC, inserting traps for IF carrier and $f_H$ is recommended.	-	-

PIN No.	PIN NAME	FUNCTION	INTERFACE CIRCUIT	INPUT / OUTPUT
53	Limiter Input / H. Correction	<p>The terminal for SIF signal input and H. curve correction. By this terminal DC (3.5V~5.5V), it is possible to adjust H. phase (<math>-1/\mu s \sim +1/\mu s</math>). This can be used to correct horizontal curve caused by change of High-Voltage.</p>		<p>Typical 90dB<math>\mu</math>V</p>
54	Ripple Filter	<p>The terminal to be connected with a capacitor to stabilize the performance of SIF injection-lock circuit.</p>		-

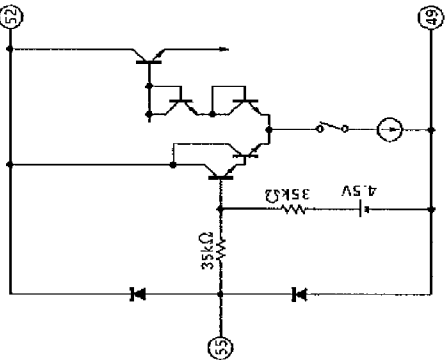
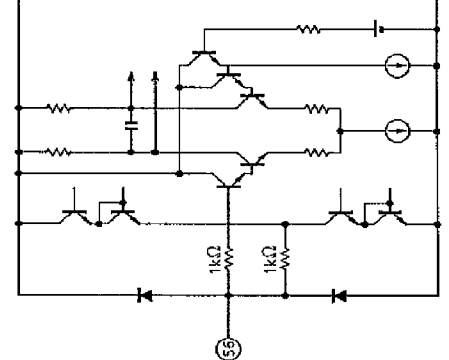

PIN No.	PIN NAME	FUNCTION	INTERFACE CIRCUIT	INPUT / OUTPUT
55	EXT. Audio Input	<p>The terminal for input of audio signal from TV's ext. jack. Input through a coupling capacitor. The signal inputted into this terminal is outputted from Pin 2 after passing audio SW and attenuator. Input impedance is 70kΩ.</p>		Center DC 4.5V
56	FM DC NF	<p>The terminal for FM DC Negative Feedback and AGC Filter for L-SECAM. Connect a capacitor to stabilize audio output DC level.</p>		DC : 5.2V

TB1238N - 25

**BUS CONTROL MAP**

Write mode

Slave address : 88HEX

SUB ADDRESS	D7 MSB	D6	D5	D4	D3	D2	D1	D0 LSB	PRESET DATA		
									MSB	LSB	
00	Au Gain	WPS	Uni-Color (TV)						0000	0000	
01	Mute	Brightness (TV/TEXT)						0100	0000		
02		Color						1100	0000		
03	V AGC	TINT						0100	0000		
04	AF-G	Vi Pol	Sharpness						0010	0000	
05	BPF / TOF SW	C-Trap	Au SW	Video SW		Half Tone	ABL Gain		0000	0000	
06	Color System			CW SW	Sub-Contrast					0000	1000
07	R Cut Off						1000	0000			
08	G Cut Off						1000	0000			
09	B Cut Off						1000	0000			
0A	*	G Drive Gain						0100	0000		
0B	AFT M	B Drive Gain						0100	0000		
0C	Vertical Position			Horizontal Position					0001	0000	
0D	B.B.	Audio ATT						0000	0000		
0E	V-Freq		RF AGC						0000	0000	
0F	AFC Gain		Vertical Size						0010	0000	
10	V Linearity			VS Correction					1000	1000	
11	PIF VCO						(Fix 0)	1000	0000		
12	SECAM R-Y Black Adj			SECAM B-Y Black Adj					1000	1000	
13	N-Com	BLK	RGB Contrast						0000	0000	
14	*	H-STP	F ID	Self Adj.		ID SW	ABL Start Point		0000	0000	
15	TEST MODE						0000	0000			
16	0	SE Adj	IF Freq.		AFT ON	BGP P	Ym enb	0000	0000		
17	TEST MODE						0000	0000			

Read mode

Slave address : 89HEX

7 MSB	6	5	4	3	2	1	0 LSB
POR	IF Lock	H Lock	IF Level	V Frq.	Color System		
Y-IN	RGB OUT	H-OUT	V-OUT	31 / 38	V Lock	AFT	

## BUS CONTROL CONTENTS

Write mode

CHARACTERISTIC	DESCRIPTION	PRESET
Au Gain (Audio Gain SW)	0 : 50kHz      1 : 25kHz (X2 on 4.5MHz mode)	50kHz
WPS (White Peak Suppressor)	0 : ON      1 : OFF	ON
Uni-Color	Min : -11.6dB~Cen : 6.6dB~Max : 11.6dB	-11.6dB
Mute (Mute Mode)	00 : Normal   01 : Y-Mute 10 : RGB Out-Cut Off DC 11 : RGB Out-Cut Off DC + VP Out Hi (Service mode)	Y-Mute
Brightness	Min : 1.9V~Cen : 2.6V~Max : 3.4V (Pedestal Level)	2.6V
Color	Min : -20dB or less~Cen : 0dB~Max : 8.15dB	0dB
V-AGC (Vertical AGC Speed)	0 : Normal      1 : x3	Normal
TINT	Min : -38°~Cen : 0°~Max : 38°	0°
AF-G (AF Gain SW)	0 : 50 $\mu$ s (5.5 / 6.0 / 6.5MHz)   1 : 75 $\mu$ s (4.5MHz)	50 $\mu$ s
Vi POL (Video Polarity)	0 : Normal      1 : Reverse (For L-SECAM)	Normal
Sharpness	Min : -11dB~Cen : 5dB~Max : 12dB	0dB
BPF / TOF SW	0 : BPF      1 : TOF	BPF
C-Trap (Chroma Trap)	0 : OFF      1 : ON	OFF
AU SW (Audio SW)	0 : TV      1 : EXT.	TV
Video SW	00 : TV   01 : EXT.   10 : TV Y/C   11 : EXT Y/C	TV
Half Tone	0 : OFF      1 : ON	OFF
ABL Gain	00 : -0.74V   01 : -0.64V   10 : -0.37V   11 : -0.12V	-0.74V
Color System	000 : Auto1...443PAL / 358NTSC (/ SECAM) / 443NTSC 001 : Auto2...358NTSC / M-PAL / N-PAL 010 : Fixed 443PAL   011 : Fixed M-PAL 100 : Fixed N-PAL   101 : Fixed 358NTSC 110 : Fixed 443NTSC   111 : SECAM	Auto1
CW SW	0 : Auto      1 : 4.43MHz	Auto
Sub-Contrast	Min : -3.5dB~Cen : 0dB~Max : 2.3dB	0dB
RGB Cut Off	Min : -0.5V~Cen : 0V~Max : 0.5V	$\pm$ 0dB
G / B Drive	Min : -5.5dB~Cen : 0dB~Max : 3.5dB	-5dB
AFT M (AFT Mute)	0 : Normal      1 : Mute	Normal
Vertical Position	000 : 0H    111 : 7H    Delay / Pulse Width : 8H	0H
Horizontal Position	Min : -3 $\mu$ s~Cen : 0 $\mu$ s~Max : 3 $\mu$ s	0 $\mu$ s
B.B. (Blue Back)	0 : OFF      1 : 50IRE	OFF
Audio ATT	Min : -85dB~Cen : -15dB~Max : 0dB	Min
V-Freq (Vertical Frequency)	00 : Auto   01 : 60Hz   10 : 263H Fixed 11 : 313H Fixed	Auto
RF AGC	000000 : IF Mute   Min : 65dB $\mu$ V~Max 100dB $\mu$ V	IF Mute
AFC Gain	00 : Normal   01 : 1/3   10 : x3 at VBLK 11 : AFC Off	Normal
Vertical Size	Min : -40%~Cen : 0%~Max : 40%	0%

1998-03-12 27/77



Read mode

CHARACTERISTIC	DESCRIPTION	
POR (Power On Resection)	0 : Normal	1 : Resister Preset
IF Lock (IF Lock Detection)	0 : Lock Out	1 : Lock In
H-Lock (Horizontal Lock Detection)	0 : Lock Out	1 : Lock In
IF Level (IF AGC Gain Detection)	0 : High IF AGC Gain	1 : Low IF AGC Gain
V Frq (Vertical Frequency)	0 : 50Hz	1 : 60Hz
Color System	000 : B/W 001 : 4.43PAL 010 : M-PAL 011 : N-PAL 100 : 3.58NTSC 101 : 4.43NTSC 110 : SECAM 111 : N/A	
Y-IN (For Self-Diagnostic)	0 : No Signal	1 : OK
RGB Output (For Self-Diagnostic)	0 : No Signal	1 : OK
H-OUT (For Self-Diagnostic)	0 : No Signal	1 : OK
V-OUT (For Self-Diagnostic)	0 : No Signal	1 : OK
V-Lock (Vertical Lock Detection)	0 : Lock Out	1 : Lock In
AFT (AFT Lock Detection)	00 : Lock Out 11 : Lock In	01 : High Freq. 10 : Low Freq.
31 / 38 Recognition	0 : TB1231N	1 : TB1238N

**I<sup>2</sup>C BUS CONTROLLED FORMAT SUMMARY**

Bus controlled format of TB1238N is based on I<sup>2</sup>C Bus Control format of Philips.

Data transfer format

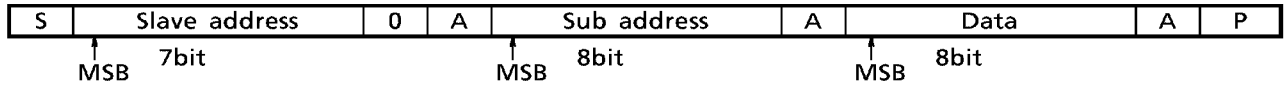

S : Start Condition  
 P : Stop Condition  
 A : Acknowledge

**(1) Start and stop condition**

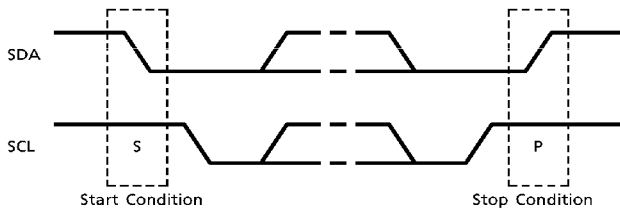

**(2) Bit transfer**

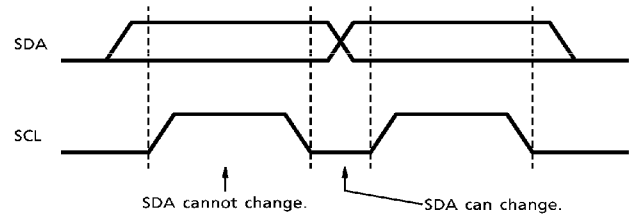

**(3) Acknowledge**

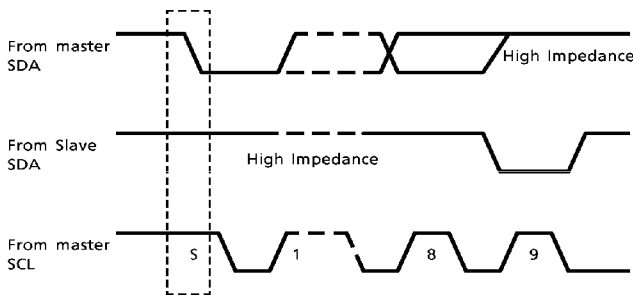

**(4) Slave address**

A <sub>6</sub>	A <sub>5</sub>	A <sub>4</sub>	A <sub>3</sub>	A <sub>2</sub>	A <sub>1</sub>	A <sub>0</sub>	R / $\bar{W}$
1	0	0	0	1	0	0	0

Purchase of TOSHIBA I<sup>2</sup>C components conveys a license under the Philips I<sup>2</sup>C Patent Rights to use these components in an I<sup>2</sup>C system, provided that the system conforms to the I<sup>2</sup>C Standard Specification as defined by Philips.

**MAXIMUM RATINGS (Ta = 25°C)**

CHARACTERISTIC	SYMBOL	RATING	UNIT
Supply Voltage (9V V <sub>CC</sub> )	V <sub>CCmax9</sub>	12	V
Supply Voltage (5V V <sub>CC</sub> )	V <sub>CCmax5</sub>	8	V
Power Dissipation	PD <sub>max</sub>	1980 (*)	mW
Input Terminal Voltage	V <sub>in</sub>	GND - 0.3~V <sub>CC</sub> + 0.3	V
Operating Temperature	T <sub>opr</sub>	- 20~65	°C
Storage Temperature	T <sub>stg</sub>	- 55~150	°C

(\*) When using this device at above Ta = 25°C, the power dissipation decreases by 15.9mW per 1°C rise.

**Ta-PD CURVE**

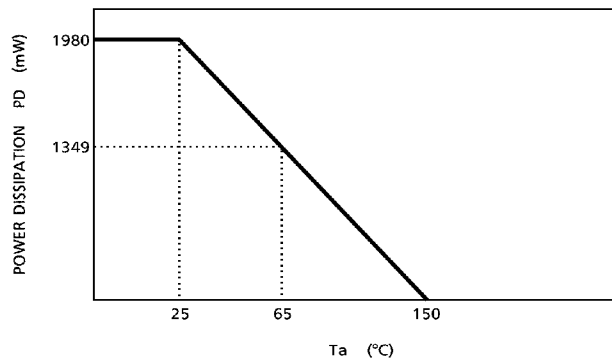

## ELECTRICAL CHARACTERISTICS

## DC CHARACTERISTICS

Pin voltage

PIN No.	PIN NAME	SYMBOL	TEST CIR-CUIT	TEST CONDITION	MIN.	TYP.	MAX.	UNIT
1	De-Emphasis	V <sub>1</sub>	—	—	4.5	5.0	5.5	V
2	Audio Output	V <sub>2</sub>	—	—	3.0	3.6	4.2	V
3	IF V <sub>CC</sub>	V <sub>3</sub>	—	Supply 9V	—	9.0	—	V
4	AFT Output	V <sub>4</sub>	—	—	2.0	2.5	3.0	V
7	IF Input	V <sub>7</sub>	—	—	2.1	2.7	3.3	V
10	APC Filter	V <sub>10</sub>	—	—	1.8	2.5	3.2	V
11	X'tal	V <sub>11</sub>	—	—	37	4.0	4.3	V
13	Y <sub>S</sub>	V <sub>13</sub>	—	—	—	0.17	0.4	V
14	Analog R Input	V <sub>14</sub>	—	—	1.8	2.5	3.2	V
15	Analog G Input	V <sub>15</sub>	—	—	1.8	2.5	3.2	V
16	Analog B Input	V <sub>16</sub>	—	—	1.8	2.5	3.2	V
17	RGB V <sub>CC</sub>	V <sub>17</sub>	—	Supply 9V	—	9.0	—	V
18	R Output	V <sub>18</sub>	—	—	2.30	2.65	3.00	V
19	G Output	V <sub>19</sub>	—	—	2.30	2.65	3.00	V
20	B Output	V <sub>20</sub>	—	—	2.30	2.65	3.00	V
21	ABCL	V <sub>21</sub>	—	—	5.70	6.05	6.30	V
26	SCL	V <sub>26</sub>	—	—	4.5	5.0	5.5	V
27	SDA	V <sub>27</sub>	—	—	4.5	5.0	5.5	V
28	H.V <sub>CC</sub>	V <sub>26</sub>	—	Supply 9V	—	9.0	—	V
29	ID In / Output / Fsc CW Output	V <sub>29</sub>	—	—	1.40	1.75	2.00	V
35	Video SW Output	V <sub>35</sub>	—	—	1.90	2.15	2.50	V
36	Digital V <sub>DD</sub>	V <sub>36</sub>	—	Supply 5V	—	5.0	—	V
37	SECAM B-Y Input	V <sub>37</sub>	—	—	2.3	2.5	2.7	V
38	SECAM R-Y Input	V <sub>38</sub>	—	—	2.3	2.5	2.7	V
39	Y Input	V <sub>39</sub>	—	—	2.5	2.8	3.2	V
40	H.AFC	V <sub>40</sub>	—	—	6.0	6.8	7.5	V
41	Ext. Video / Y Input	V <sub>41</sub>	—	Video SW : 01	2.7	3.0	3.4	V
43	TV Video Input	V <sub>43</sub>	—	Video SW : 00	2.7	3.0	3.4	V
44	Black Detection	V <sub>44</sub>	—	—	2.00	2.25	2.60	V
45	Ext. C Input	V <sub>45</sub>	—	—	2.7	3.0	3.4	V
46	Y / C V <sub>CC</sub>	V <sub>46</sub>	—	Supply 5V	—	5.0	—	V
47	PIF Det. Output	V <sub>47</sub>	—	—	4.8	5.3	5.8	V
48	Loop Filter	V <sub>48</sub>	—	—	4.1	4.6	5.1	V



PIN No.	PIN NAME	SYMBOL	TEST CIR-CUIT	TEST CONDITION	MIN.	TYP.	MAX.	UNIT
50	PIF VCO	V50	—	—	7.4	8.0	8.6	V
51	PIF VCO	V51	—	—	7.4	8.0	8.6	V
52	VCO VCC	V52	—	Supply 9V	—	9.0	—	V
53	Limiter Input/ Curre Correction	V53	—	—	3.9	4.5	5.1	V
54	Ripple Filter	V54	—	—	5.2	5.9	6.6	V
55	Ext. Audio Input	V55	—	—	3.8	4.4	5.0	V

## Current dissipation

PIN No.	PIN NAME	SYMBOL	TEST CIR-CUIT	TEST CONDITION	MIN.	TYP.	MAX.	UNIT
3	IF VCC	I <sub>CC3</sub>	—	Supply 9V	8.5	15	19	mA
17	RGB VCC	I <sub>CC17</sub>	—	Supply 9V	8.5	12	14	mA
28	H.VCC	I <sub>CC26</sub>	—	Supply 9V	12	16	22	mA
36	Digital VCC	I <sub>CC36</sub>	—	Supply 5V	7	12	15	mA
46	Y/C VCC	I <sub>CC46</sub>	—	Supply 5V	45	65	76	mA
52	VCO VCC	I <sub>CC52</sub>	—	Supply 9V	15.5	23	29	mA

## RECOMMENDED OPERATING POWER SUPPLY VOLTAGE

PIN No.	PIN NAME	MIN.	TYP.	MAX.	UNIT	NOTE
3	IF VCC	8.5	9	9.5	V	—
17	RGB VCC	8.5	9	9.5	V	—
28	H.VCC	8.5	9	9.5	V	—
36	Digital VCC	4.5	5	5.5	V	—
46	Y/C VCC	4.5	5	5.5	V	The thermal drift of the Y/C VCC should be less than 50mV. Because the Amplitude of V-RAMP depends on this DC voltage.
52	VCO VCC	8.5	9	9.5	V	—

**AC CHARACTERISTIC**

PIF stage (Unless otherwise specified,  $V_{CC} = 9V$  (3, 17, 28 & 52pin) /  $5V$  (36 & 46pin),  $T_a = 25^\circ C$ )

CHARACTERISTIC		SYMBOL	TEST CIRCUIT	TEST CONDITION	MIN.	TYP.	MAX.	UNIT
PIF Det. Output Level	87.5%	$V_{DET875}$	—	P <sub>1</sub>	2.0	2.2	2.4	$V_{p-p}$
	L-SECAM	$V_{DETLS}$			2.0	2.2	2.4	
	110%	$V_{DET110}$			2.0	2.5	3.0	
PIF Input Sensitivity	MIN.	$E_{PIFINMIN}$	—	P <sub>2</sub>	—	37	—	$dB_{\mu V}$
	MAX.	$E_{PIFINMAX}$			100	107	—	
IF AGC Range		$\Delta E_{IFAGC}$	—		65	70	—	dB
PIF Det. Sync. Tip Level		$V_{SYNC}$	—	P <sub>3</sub>	2.6	2.9	3.2	V
L-SECAM White Peak Level		$V_{LSW}$			4.6	4.9	5.2	V
Output Level for No Input	—	$V_{NOIF}$	—	P <sub>4</sub>	4.8	5.2	5.6	V
	L-SECAM	$V_{NOIFLS}$			2.2	2.6	3	
Differential Gain		DG	—	P <sub>5</sub>	—	2	5	%
Differential Phase		DP			—	2	5	°
PIF Output Freq. Response		$FR_{DET}$	—	P <sub>6</sub>	5	7	—	MHz
S/N		$S/N_{PIF}$	—	P <sub>7</sub>	52	55	—	dB
Intermodulation		$I_{107}$	—	P <sub>8</sub>	42	45	—	dB
$I_F$ AGC Voltage	MAX.	$V_{IFAGCMAX}$	—	P <sub>9</sub>	7.3	7.5	—	V
	MIN.	$V_{IFAGCMIN}$			—	3.8	—	
$R_F$ AGC Voltage	MAX.	$V_{RFAGCMAX}$	—	P <sub>10</sub>	—	9	—	V
	MIN.	$V_{RFAGCMIN}$			—	0.2	0.5	
$R_F$ AGC Control Range		$\Delta E_{RFAGC}$	—	P <sub>11</sub>	35	—	—	dB
AFT Center Voltage		$V_{AFTCEN}$	—	P <sub>12</sub>	—	2.5	—	V
AFT Voltage	MAX.	$V_{AFTMAX}$	—	P <sub>13</sub>	4.4	4.8	5.2	V
	MIN.	$V_{AFTMIN}$			—	0.2	0.5	
AFT Sensitivity		$\mu AFT$	—	P <sub>14</sub>	—	40	—	kHz/V
PIF VCO Control Sensitivity		$\beta_{IFVCO}$	—	P <sub>15</sub>	—	2.5	—	MHz/V
PIF VCO Pull-In Range	High	$F_{PIFINH}$	—	P <sub>16</sub>	1	1.5	—	MHz
	Low	$F_{PIFINL}$			1	1.5	—	

SIF & audio stage (Unless otherwise specified,  $V_{CC} = 9V$  (3, 17, 28 & 52pin) /  $5V$  (36 & 46pin),  $T_a = 25^{\circ}C$ )

CHARACTERISTIC		SYMBOL	TEST CIR-CUIT	TEST CONDITION	MIN.	TYP.	MAX.	UNIT
FM Det. Output Level	5.5MHz / P	VAUAC5P	—	S <sub>1</sub>	695	927	1236	mV <sub>rms</sub>
	4.5MHz / P	VAUAC4P			649	927	1324	
	4.5MHz / N	VAUAC4N			350	500	700	
Audio Distortion	5.5MHz / P	DAUDIOP	—	S <sub>2</sub>	—	0.3	1	%
	4.5MHz / P	DAUDION			—	0.3	1	
Audio S / N	5.5MHz / P	S / N <sub>SIFP</sub>	—	S <sub>3</sub>	55	60	—	dB
	4.5MHz / P	S / N <sub>SIFN</sub>			52	58	—	
AMR		AMR	—	S <sub>4</sub>	50	60	—	dB
Limiting Sensitivity		ELIM	—	S <sub>5</sub>	—	35	—	dB $\mu$ V
Band Width (5.5MHz / PAL)	High	FAUH5P	—	S <sub>6</sub>	6.7	8.7	—	MHz
	Low	FAUL5P			—	3.8	5.4	
Band Width (4.5MHz / NTSC)	High	FAUH4N	—	S <sub>7</sub>	4.9	6.4	—	MHz
	Low	FAUL4N			—	2.8	4	
Attenuator Gain	MAX.	GATTMAX	—	S <sub>8</sub>	—	0	—	dB
	CEN.	GATTCEN			—	-15	—	
	MIN.	GATTMIN			—	-85	-75	
Offset between TV / Ext		VAUOFFSET	—	S <sub>9</sub>	-30	0	30	mV
DC Change by Volume		$\Delta V_{VOLDC}$	—	S <sub>10</sub>	—	—	100	mV

Video stage (Unless otherwise specified,  $V_{CC} = 9V$  (3, 17, 28 & 52pin) /  $5V$  (36 & 46pin),  $T_a = 25^\circ C$ )

CHARACTERISTIC	SYMBOL	TEST CIR-CUIT	TEST CONDITION	MIN.	TYP.	MAX.	UNIT
TV Input Dynamic Range	DR <sub>TV</sub>	—	V <sub>1</sub>	1.2	1.4	—	V <sub>p-p</sub>
External Input Dynamic Range	DR <sub>EXT</sub>			1.2	1.4	—	V <sub>p-p</sub>
TV Mode Gain	G <sub>TV</sub>	—	V <sub>2</sub>	5.2	6.0	6.4	dB
External Mode Gain	G <sub>EXT</sub>			5.2	6.0	6.4	dB
AV SW Cross-Talk	CT <sub>SWTE</sub>	—	V <sub>3</sub>	—	-55	-50	dB
	CT <sub>SWET</sub>			—	-55	-50	dB
Y Input Dynamic Range	DR <sub>Y</sub>	—	V <sub>4</sub>	1.1	1.3	—	V <sub>p-p</sub>
Y Input Pedestal Clamp Voltage	V <sub>YCLP</sub>	—	V <sub>5</sub>	2.5	2.7	2.9	V
Y Delay Time	t <sub>YDEL</sub>	—	V <sub>6</sub>	500	550	600	ns
Brightness Chara.	V <sub>BRTMAX</sub>	—	V <sub>7</sub>	3.0	3.4	3.7	V
	V <sub>BRTCEN</sub>			2.3	2.6	2.8	
	V <sub>BRTMIN</sub>			1.6	1.9	2.1	
Brightness Data Sensitivity	$\Delta V_{BRT}$	—	V <sub>7</sub>	9.4	13.6	16.3	mV/bit
Uni-Color Chara. for Y	G <sub>UCYMAX</sub>	—	V <sub>8</sub>	10.2	11.6	13.2	dB
	G <sub>UCYCEN</sub>			5.1	6.6	8.3	
	G <sub>UCYMIN</sub>			-9.1	-6.9	-5.2	
Sub-Contrast Chara.	G <sub>SCONMAX</sub>	—	V <sub>9</sub>	1.8	2.3	2.8	dB
	G <sub>SCONMIN</sub>			-3.0	-3.5	-4.0	
Sharpness Peaking Frequency	F <sub>SHP</sub>	—	V <sub>10</sub>	3.0	3.3	3.6	MHz
Sharpness Control Characteristics	G <sub>SHMAX</sub>	—	V <sub>11</sub>	7.0	12.0	15.0	dB
	G <sub>SHCEN</sub>			2.0	5.0	7.0	
	G <sub>SHMIN</sub>			-14.0	-11.0	-8.0	
Y Frequency Response	FR <sub>Y</sub>	—	V <sub>12</sub>	5.5	—	—	MHz
Black Expansion AMP Gain	G <sub>BLEX</sub>	—	V <sub>13</sub>	1.2	1.4	1.6	—
Black Expansion Start Point	V <sub>BLEX</sub>			0.9	1.1	1.3	V
Black Peak Detection Level	V <sub>BLPD</sub>	—	V <sub>14</sub>	-50	0	50	mV
WPS Level	V <sub>WPS</sub>	—	V <sub>15</sub>	2.5	2.8	3.2	V <sub>p-p</sub>
Chrome Trap Gain	G <sub>TRAP 358</sub>	—	V <sub>16</sub>	—	—	-20	dB
	G <sub>TRAP 443</sub>			—	—	-20	dB
Half Tone Chara. for Y	G <sub>HTY</sub>	—	V <sub>17</sub>	-6.9	-6.0	-5.1	dB

Chroma stage (Unless otherwise specified, V<sub>CC</sub> = 9V (3, 17, 28 & 52pin) / 5V (36 & 46pin), Ta = 25°C)

CHARACTERISTIC	SYMBOL	TEST CIRCUIT	TEST CONDITION	MIN.	TYP.	MAX.	UNIT
ACC Chara.	V <sub>ACCL</sub>	—	C <sub>1</sub>	—	20	30	mV <sub>p-p</sub>
	V <sub>ACCH</sub>			600	—	—	
TOF Chara. (4.43MHz)	F <sub>0T443</sub>	—	C <sub>2</sub>	—	5.13	—	MHz
	Q <sub>T443</sub>			—	2.0	—	—
BPF Chara. (4.43MHz)	F <sub>0B443</sub>	—	C <sub>2</sub>	—	4.43	—	MHz
	Q <sub>B443</sub>			—	2.0	—	—
TOF Chara. (3.58MHz)	F <sub>0T358</sub>	—	C <sub>2</sub>	—	4.28	—	MHz
	Q <sub>T358</sub>			—	2.0	—	—
BPF Chara. (3.58MHz)	F <sub>0B358</sub>	—	C <sub>2</sub>	—	3.58	—	MHz
	Q <sub>B358</sub>			—	2.0	—	—
C Delay Time	t <sub>CDEL</sub>	—	C <sub>3</sub>	550	600	650	ns
Delay Time Difference between Y/C	Δt <sub>Y/C</sub>			-60	0	60	ns
Color Chara.	G <sub>COLMAX</sub>	—	C <sub>4</sub>	6.93	8.15	9.37	dB
	G <sub>COLMIN</sub>			—	—	-20	
Uni-Color Chara. for C	G <sub>UCCMIN</sub>	—	C <sub>5</sub>	-21.5	-18.8	-16.0	dB
Tint Chara. (4.43MHz)	Δθ <sub>443MAX</sub>	—	C <sub>6</sub>	30	38	46	deg
	Δθ <sub>443MIN</sub>			-46	-38	-30	
Tint Chara. (3.58MHz)	Δθ <sub>358MAX</sub>	—	C <sub>6</sub>	30	38	46	deg
	Δθ <sub>358MIN</sub>			-46	-38	-30	
Relative Amplitude (PAL)	V <sub>PR/B</sub>	—	C <sub>7</sub>	0.45	0.55	0.65	—
	V <sub>PG/B</sub>			0.30	0.36	0.42	
Relative Amplitude (NTSC)	V <sub>PR/B</sub>	—	C <sub>7</sub>	0.6	0.7	0.8	—
	V <sub>PG/B</sub>			0.25	0.31	0.37	
Relative Phase (PAL)	θ <sub>PR-B</sub>	—	C <sub>8</sub>	85	90	95	deg
	θ <sub>PG-B</sub>			230	236	242	
Relative Phase (NTSC)	θ <sub>PR-B</sub>	—	C <sub>8</sub>	86	91	96	deg
	θ <sub>PG-B</sub>			232	240	245	
APC Pull-In Range (4.43MHz)	F <sub>4APCP+</sub>	—	C <sub>9</sub>	350	500	—	Hz
	F <sub>4APCP-</sub>			350	500	—	
APC Hold Range (4.43MHz)	F <sub>4APCH+</sub>	—	C <sub>9</sub>	350	500	—	Hz
	F <sub>4APCH-</sub>			350	500	—	
APC Pull-In Range (3.58MHz)	F <sub>3APCP+</sub>	—	C <sub>9</sub>	350	500	—	Hz
	F <sub>3APCP-</sub>			350	500	—	
APC Hold Range (3.58MHz)	F <sub>3APCH+</sub>	—	C <sub>9</sub>	350	500	—	Hz
	F <sub>3APCH-</sub>			350	500	—	
APC Control Sensitivity (4.43MHz)	β <sub>443</sub>	—	C <sub>10</sub>	0.8	1.0	1.2	Hz/mV
APC Control Sensitivity (4.43MHz)	β <sub>358</sub>			0.7	0.9	1.1	Hz/mV

CHARACTERISTIC	SYMBOL	TEST CIR-CUIT	TEST CONDITION	MIN.	TYP.	MAX.	UNIT
PAL ID Sensitivity (Normal Mode)	VPALIDON	—	C11	1.0	3.0	5.0	mV <sub>p-p</sub>
	VPALIDOFF			1.0	3.0	5.0	
NTSC ID Sensitivity (Normal Mode)	VNTIDON			0.4	0.8	1.2	mV <sub>p-p</sub>
	VNTIDOFF			0.4	0.8	1.2	
NTSC ID Sensitivity (Low Mode)	VNTIDLON			2	4	6	mV <sub>p-p</sub>
	VNTIDLOFF			2	4	6	
ID Output Level	VIDH	—	C12	2.9	3.2	3.5	V
	VIDL			1.5	1.8	2.1	
SECAM ID Det. Current	I <sub>SECAM</sub>	—	C13	50	70	150	μA
SECAM ID Det. Current (Strong)	I <sub>SECAM-S</sub>	—	C14	220	300	380	μA
fsc Continuous Wave Output Level	V <sub>CW</sub>	—	C15	0.35	0.50	0.70	V <sub>p-p</sub>
Sub-Carrier Remain on RGB Output	V <sub>SCR</sub>	—	C16	0	20	40	mV <sub>p-p</sub>
	V <sub>SCG</sub>			0	20	40	
	V <sub>SCB</sub>			0	20	40	
Half Tone Chara. for C	GHTC	—	C17	-6.9	-6.0	-5.1	dB

Text stage (Unless otherwise specified,  $V_{CC} = 9V$  (3, 17, 28 & 52pin) /  $5V$  (36 & 46pin),  $T_a = 25^\circ C$ )

CHARACTERISTIC	SYMBOL	TEST CIRCUIT	TEST CONDITION	MIN.	TYP.	MAX.	UNIT	
V-BLK Pulse Output Level	$V_{VBLK}$	—	T <sub>1</sub>	0.5	1.0	1.5	V	
H-BLK Pulse Output Level	$V_{HBLK}$			0.5	1.0	1.5	V	
RGB Output Black Level (0IRE DC)	$V_{BLACK}$	—	T <sub>2</sub>	2.35	2.60	2.85	V	
RGB Output White Level (100IRE AC)	$V_{WHITE}$	—	T <sub>3</sub>	—	2.50	—	$V_{p-p}$	
Cut-Off Voltage Variable Range	$\Delta V_{CUT+}$	—	T <sub>4</sub>	0.45	0.50	0.55	V	
	$\Delta V_{CUT-}$			-0.55	-0.50	-0.45		
Drive Control Variable Range	GDR +	—	T <sub>5</sub>	3.0	3.5	4.0	dB	
	GDR -			-6.0	-5.5	-5.0		
ABCL Control Voltage Range	$V_{ABCLH}$	—	T <sub>6</sub>	6.0	6.1	6.2	V	
	$V_{ABCLL}$			5.4	5.5	5.6		
ACL Gain	GACL	—		-16.5	-15	-13.5	dB	
ABL Point	$V_{ABLP1}$	—	T <sub>7</sub>	-0.06	-0.01	0.04	V	
	$V_{ABLP2}$			-0.16	-0.11	-0.06		
	$V_{ABLP3}$			-0.35	-0.30	-0.25		
	$V_{ABLP4}$			-0.47	-0.42	-0.37		
ABL Gain	$V_{ABLG1}$	—	T <sub>8</sub>	-0.17	-0.12	-0.07	V	
	$V_{ABLG2}$			-0.42	-0.37	-0.32		
	$V_{ABLG3}$			-0.69	-0.64	-0.59		
	$V_{ABLG4}$			-0.79	-0.74	-0.69		
Analog RGB Dynamic Range	DR <sub>TX</sub>	—	T <sub>9</sub>	0.5	—	—	$V_{p-p}$	
Analog RGB Contrast Control Characteristic	MAX.	GTXC <sub>MAX</sub>	—	T <sub>10</sub>	0.85	1.00	1.20	$V_{p-p}$
	CEN.	GTXC <sub>CEN</sub>			0.50	0.59	0.71	
	MIN.	GTXC <sub>MIN</sub>			0.08	0.10	0.12	
Analog RGB Brightness Control Characteristic	MAX.	VTXB <sub>RMAX</sub>	—	T <sub>11</sub>	3.0	3.4	3.7	V
	CEN.	VTXB <sub>Rcen</sub>			2.3	2.6	2.8	
	MIN.	VTXB <sub>Rmin</sub>			1.6	1.9	2.1	
Analog RGB Mode Switching Level	$V_{YS}$	—	T <sub>12</sub>	0.6	0.8	1.0	V	
Analog RGB Mode Transfer Characteristic	$\tau_{RYS}$	—	T <sub>13</sub>	—	25	100	ns	
	tPR <sub>YS</sub>			—	30	100		
	$\tau_{FYS}$			—	10	100		
	tPF <sub>YS</sub>			—	25	100		
Cross Talk from Analog RGB to TV	CT <sub>TX-TV</sub>	—	T <sub>14</sub>	—	-55	-50	dB	
Cross Talk from TV to Analog RGB	CT <sub>TV-TX</sub>	—	T <sub>15</sub>	—	-55	-50	dB	

CHARACTERISTIC		SYMBOL	TEST CIR-CUIT	TEST CONDITION	MIN.	TYP.	MAX.	UNIT
RGB Output Amplitude	R	V <sub>ROUT</sub>	—	T <sub>19</sub>	1.0	1.2	1.4	V <sub>p-p</sub>
	G	V <sub>GOUT</sub>			0.45	0.60	0.75	
	B	V <sub>BOUT</sub>			2.0	2.2	2.4	
SECAM Black Level Adj. Chara.		V <sub>SECBMAX</sub>	—	T <sub>20</sub>	210	245	280	mV
		—			—	—		
		V <sub>SECRMAY</sub>			133	154	175	mV
		V <sub>SECBMIN</sub>			-320	-280	-240	
SECAM Black Level Adj. Data Sensitivity		V <sub>SECRMIL</sub>	—		-200	-176	-152	mV
		ΔV <sub>SECB</sub>			30	35	40	
		ΔV <sub>SECR</sub>			19	22	25	mV

1H DL stage (Unless otherwise specified, V<sub>CC</sub> = 9V (3, 17, 28 & 52pin) / 5V (36 & 46pin), Ta = 25°C)

CHARACTERISTIC	SYMBOL	TEST CIR-CUIT	TEST CONDITION	MIN.	TYP.	MAX.	UNIT
1H DL Dynamic Range (Direct)	DR <sub>BDR</sub>	—	Pin 37~Pin 20	0.8	1.2	—	V
	DR <sub>RDR</sub>		Pin 38~Pin 18	0.8	1.2	—	
1H DL Dynamic Range (Delay)	DR <sub>pDL</sub>	—	Pin 37~Pin 20	0.8	1.2	—	V
	DR <sub>pDL</sub>		Pin 38~Pin 18	0.8	1.2	—	
1H DL Dynamic Range (Direct + Delay)	DR <sub>BDRDL</sub>	—	Pin 37~Pin 20	0.9	1.2	—	V
	DR <sub>RDRDL</sub>		Pin 38~Pin 18	0.9	1.2	—	
Frequency Response (Direct)	FR <sub>BDR</sub>	—	At 700kHz	-3.0	-2.0	0.5	dB
	FR <sub>RDR</sub>		At 700kHz	-3.0	-2.0	0.5	
Frequency Response (Delay)	FR <sub>BDL</sub>	—	At 700kHz	-8.2	-6.5	-4.3	dB
	FR <sub>RDL</sub>		At 700kHz	-8.2	-6.5	-4.3	
AC Gain (Direct)	GB <sub>DR</sub>	—	Pin 37~Pin 20	-2.0	-0.5	2.0	dB
	GB <sub>RDR</sub>		Pin 38~Pin 18	-2.0	-0.5	2.0	
AC Gain (Delay)	GB <sub>DL</sub>	—	Pin 37~Pin 20	-2.4	-0.5	1.1	dB
	GB <sub>RDL</sub>		Pin 38~Pin 18	-2.4	-0.5	1.1	
Direct-Delay AC Gain Difference	ΔGB <sub>DR</sub> / DL	—	GB <sub>DR</sub> -GB <sub>DL</sub>	-1.0	0.0	1.0	dB
	ΔGB <sub>RDR</sub> / DL		GB <sub>RDR</sub> -GB <sub>RDL</sub>	-1.0	0.0	1.0	
1H Delay Time	T <sub>BDL</sub>	—	Pin 37~Pin 20	63.7	64.0	64.4	μs
	T <sub>RDL</sub>		Pin 38~Pin 18	63.7	64.0	64.4	



DEF stage (Unless otherwise specified, V<sub>CC</sub> = 9V (3, 17, 28 & 52pin) / 5V (36 & 46pin), Ta = 25°C)

CHARACTERISTIC		SYMBOL	TEST CIRCUIT	TEST CONDITION	MIN.	TYP.	MAX.	UNIT
AFC Inactive Period	50Hz	T50AFCOFF	—	D1	—	309-8	—	H
	60Hz	T60AFCOFF			—	256-10	—	
H-OUT Start Voltage		V <sub>HON</sub>	—	D2	4.7	5.0	5.3	V
H-OUT Pulse Duty		W <sub>HOUT</sub>	—	D3	38.5	40.5	42.5	%
H-OUT Freq. on AFC Stop Mode		F <sub>HAFCOFF</sub>	—	D4	15.585	15.734	15.885	kHz
Horizontal Free-Run Frequency	50Hz	F <sub>H50FR</sub>	—	D5	15.745	15.625	15.775	kHz
	60Hz	F <sub>H60FR</sub>			15.585	15.734	15.885	
Horizontal Freq. Variable Range	MAX.	F <sub>HMAX</sub>	—	D6	16.500	16.700	16.900	kHz
	MIN.	F <sub>HMIN</sub>			14.700	15.000	15.300	
Horizontal Freq. Control Sensitivity		β <sub>HAFc</sub>	—	D7	2.0	2.5	3.0	Hz / mV
Horizontal Pull-In Range		F <sub>HPh</sub>	—	D8	500	—	—	Hz
		F <sub>HPL</sub>			500	—	—	
H-OUT Voltage		V <sub>HOUTH</sub>	—	D9	4.0	4.4	4.8	V
		V <sub>HOUTL</sub>			—	0.15	0.30	
Horizontal Freq. Dependence on V <sub>CC</sub>		ΔF <sub>HVCC</sub>	—	D10	-20	0	20	Hz / V
FBP Phase		PH <sub>FBP</sub>	—	D11	2.3	2.5	2.7	μs
H-Sync. Phase		PH <sub>HSYNC</sub>			0.2	0.3	0.4	
Horizontal Position Variable Range		ΔPH <sub>HPOS</sub>	—	D12	5.5	6.0	6.5	μs
AFC-2 Pulse Threshold Level		V <sub>AFC2</sub>	—	D13	4.7	5.0	5.3	V
H-BLK Pulse Threshold Level		V <sub>HBLK</sub>	—	D14	0.8	1.1	1.4	
Black Peak Det. Stop Period (H)		PH <sub>BPDET</sub>	—	D15	7.5	8.0	8.5	μs
		W <sub>BPDET</sub>			13.0	13.5	14.0	
Clamp Pulse Start Phase		PH <sub>CP</sub>	—	D16	2.8	3.0	3.2	μs
Clamp Pulse Width		W <sub>CP</sub>			5.6	5.8	6.0	
Gate Pulse Start Phase		PH <sub>GP</sub>	—	D17	2.7	2.9	3.1	μs
Gate Pulse Width		W <sub>GP</sub>			1.8	2.0	2.2	
Sync. Output Low Level		V <sub>SYNCL</sub>	—	D18	0.0	0.3	0.5	V
Vertical Oscillation Start Voltage		V <sub>VON</sub>	—	D19	4.7	5.0	5.3	V
Vertical Free-Run Frequency	Auto	F <sub>VAUFR</sub>	—	D20	40	45	50	Hz
	60Hz	F <sub>V60FR</sub>			48	53	58	
Gate Pulse V-Masking Period	50Hz	T <sub>50GPM</sub>	—	D21	—	308-9	—	H
	60Hz	T <sub>60GPM</sub>			—	261-10	—	
V.Ramp DC on Service Mode		V <sub>NOVRAMP</sub>	—	D22	3.0	3.2	3.4	V
Vertical Pull-In Range (Auto)		F <sub>VPAUL</sub>	—	D23	—	224.5	—	H
		F <sub>VPAUH</sub>			—	353	—	
Vertical Pull-In Range (60Hz)		F <sub>V60L</sub>	—	D23	—	224.5	—	H
		F <sub>V60H</sub>			—	297	—	

CHARACTERISTIC		SYMBOL	TEST CIRCUIT	TEST CONDITION	MIN.	TYP.	MAX.	UNIT
Vertical Period on Fixed Mode		TV313	—	D24	—	313	—	H
		TV263			—	263	—	
V-BLK Start Phase	50Hz	PH50VBLK	—	D25	44	46	48	$\mu$ s
	60Hz	PH60VBLK			44	46	48	
V-BLK Width	50Hz	W50VBLK	—	D25	—	23	—	H
	60Hz	W60VBLK			—	21	—	
Picture Mute Period	50Hz	W50PM	—	D26	—	304-29	—	H
	60Hz	W60PM			—	257-28	—	
Sand Castle Pulse Level		VSCPH	—	D27	7.70	8.00	8.30	V
		VSCPM			4.00	4.30	4.60	
		VSCPL			2.25	2.55	2.85	
Vertical Ramp Amplitude		VVRAMP	—	D28	1.50	1.67	1.83	V <sub>p-p</sub>
Vertical AMP Gain		GVAMP	—	D29	22	25	28	dB
Vertical AMP Max. Output Level		VVOMAX			2.5	3.0	3.5	V
Vertical AMP Min. Output Level		VVOMIN			—	0.0	0.3	V
Vertical AMP Min. Output Current		IVOMAX	—	D30	11	14	17	mA
Vertical NFB Amplitude		VNFB	—	D31	1.50	1.67	1.83	V <sub>p-p</sub>
Vertical Amplitude Variable Range		$\Delta$ VVRAMPH			36	40	44	%
		$\Delta$ VVRAMPL	-44	-40	-36			
Vertical Linearity Variable Range		$\Delta$ VLIN1 +	—	D32	-17	-14	-11	%
		$\Delta$ VLIN1 -			13	16	19	
		$\Delta$ VLIN2 +			14.5	17.5	20.5	
		$\Delta$ VLIN2 -			-23	-20	-17	
Vertical S Correction Variable Range		$\Delta$ VS1 +	—	D33	-14	-12	-10	%
		$\Delta$ VS1 -			10	12	14	
		$\Delta$ VS2 +			-18	-15	-12	
		$\Delta$ VS2 -			12	15	18	
V-AGC Current		IVAGCH	—	D34	440	550	660	$\mu$ A
		IVAGCL			100	120	140	$\mu$ A
Vertical Guard Voltage		VVG	—	D35	1.80	2.00	2.20	V

**TEST CONDITION**

PIF stage (Unless otherwise specified,  $V_{CC}=9V$  (3, 17, 28 & 52pin) /  $5V$  (36 & 46pin),  $T_a=25^{\circ}C$ )

NOTE	ITEM / SYMBOL	BUS CONDITION	MEASUREMENT METHOD
P1	PIF Det. Output Level / $V_{DET875}$ / $V_{DETLS}$ / $V_{DET110}$	RF AGC : except 0 PIF VCO : adjust $V_i$ Pol : 0 / 1 Others : Preset	(1) Input a 38.9MHz, 90dB $\mu$ V, 87.5% modulated white signal into Pin 6. (2) Adjust PIF VCO so that the AFT voltage is 2.5V. (3) Measure the amplitude of PIF det. output at Pin 47 ( $V_i$ Pol : 0), that is " $V_{DET875}$ ". (4) Input a 38.9MHz, 90dB $\mu$ V, 87.5% modulated L-SECAM white signal into Pin 6. (5) Measure the amplitude of PIF det. output at Pin 47 ( $V_i$ Pol : 1), that is " $V_{DETLS}$ ". (6) Input a 38.9MHz, 90dB $\mu$ V, 110% modulated white signal into Pin 6. (7) Measure the amplitude of PIF det. output at Pin 47 ( $V_i$ Pol : 0), that is " $V_{DET110}$ ".
P2	PIF Input Sensitivity / $E_{PIFINMIN}$ / $E_{PIFINMAX}$	RF AGC : except 0 PIF VCO : adjust Others : Preset	(1) Input a 38.9MHz, 90dB $\mu$ V, 87.5% modulated white signal into Pin 6. (2) Adjust PIF VCO so that the AFT voltage is 2.5V. (3) Decreasing the IF input level, measure the input level at which PIF det. output amplitude turns to be -3dB against $V_{DET875}$ that is " $E_{PIFINMIN}$ ". (4) Increasing the IF input level, measure the input level at which PIF det. output amplitude turns to be -0.5dB against $V_{DET875}$ that is " $E_{PIFINMAX}$ ". (5) Calculate ; " $\Delta E_{IFAGC}$ " = $E_{PIFINMAX} - E_{PIFINMIN}$
	IF AGC Range / $\Delta E_{IFAGC}$		
P3	PIF Det. Sync. Tip Level / $V_{SYNC}$	RF AGC : except 0 PIF VCO : adjust $V_i$ Pol : 0 / 1 Others : Preset	(1) Input a 38.9MHz, 90dB $\mu$ V, non-modulation signal into Pin 6. (2) Adjust PIF VCO so that the AFT voltage is 2.5V. (3) Measure the DC level at Pin 47 ( $V_i$ Pol : 0), that is " $V_{SYNC}$ ". (4) Measure the DC level at Pin 47 ( $V_i$ Pol : 1), that is " $V_{LSW}$ ".
	L-SECAM White Peak Level / $V_{LSW}$		

NOTE	ITEM / SYMBOL	BUS CONDITION	MEASUREMENT METHOD
P4	Output Level for No Input /V <sub>NOIF</sub> /V <sub>NOIFLS</sub>	RF AGC : except 0 V <sub>i</sub> Pol : 0 / 1 Others : Preset	(1) Connect Pin 6 / 7 to GND. (2) Supply 3.0V to Pin 9. (3) Measure the DC level at Pin 47 (V <sub>i</sub> Pol : 0), that is "V <sub>NOIF</sub> ". (4) Measure the DC level at Pin 47 (V <sub>i</sub> Pol : 1), that is "V <sub>NOIFLS</sub> ".
P5	Differential Gain / DG Differential Phase / DP	RF AGC : except 0 PIF VCO : adjust Others : Preset	(1) Input a 38.9MHz, 90dB <sub>μ</sub> V, 87.5% modulated video signal into Pin 6. (2) Adjust PIF VCO so that the AFT voltage is 2.5V. (3) Measure "DG" & "DP" for Pin 47 output.
P6	PIF Output Freq. Response / FR <sub>DET</sub>	RF AGC : except 0 PIF VCO : adjust Others : Preset	(1) Input a 38.9MHz, 90dB <sub>μ</sub> V, 87.5% modulated sweep video signal into Pin 6. (2) Adjust PIF VCO so that the AFT voltage is 2.5V. (3) Measure the Pin 9 DC level and fix it on that value. (4) For PIF det. output signal, measure the frequency at which the amplitude (Without sync) turns to be -3dB against the one for 10kHz, that is "FR <sub>DET</sub> ".
P7	S / N / S / N <sub>PIF</sub>	RF AGC : except 0 PIF VCO : adjust Others : Preset	(1) Input a 38.9MHz, 90dB <sub>μ</sub> V, non-modulation signal into Pin 6. (2) Adjust PIF VCO so that the AFT voltage is 2.5V. (3) Measure the amplitude of PIF det. output, that is V <sub>N</sub> . (4) Calculate ; "S / N <sub>PIF</sub> " = 20 * log (V <sub>DET875</sub> / V <sub>N</sub> )
P8	Intermodulation / I <sub>107</sub>	RF AGC : except 0 PIF VCO : adjust Others : Preset	(1) Input a signal composed of following 3 signals into Pin 6; 38.9MHz / 90dB <sub>μ</sub> V, 34.47MHz / 84dB <sub>μ</sub> V 33.4MHz / 84dB <sub>μ</sub> V (2) Adjust PIF VCO so that the AFT voltage is 2.5V. (3) Adjust Pin 9 voltage so that the bottom of PIF det. output is equal to V <sub>SYNC</sub> . (4) Measure the 1.07MHz level against the 4.43MHz level (= 0dB), that is "I <sub>107</sub> ".

NOTE	ITEM / SYMBOL	BUS CONDITION	MEASUREMENT METHOD
P9	IF AGC Voltage /VIFAGCMAX /VIFAGCMIN	RF AGC : except 0 PIF VCO : adjust Others : Preset	(1) Connect Pin 6 / 7 to GND. (2) Measure the Pin 9 voltage, that is "VIFAGCMAX". (3) Input a 38.9MHz, 107dB $\mu$ V, non-modulation signal into Pin 6. (4) Adjust PIF VCO so that the AFT voltage is 2.5V. (5) Measure the Pin 9 voltage, that is "VIFAGCMIN".
P10	RF AGC Voltage /VRFAGCMIN /VRFAGCMAX	RF AGC : adjust PIF VCO : adjust Others : Preset	(1) Input a 38.9MHz, 90dB $\mu$ V, non-modulation signal into Pin 6. (2) Adjust PIF VCO so that the AFT voltage is 2.5V. (3) Adjust RF AGC so that the Pin 9 voltage is 4.5V. (4) Increase the IF input level to 107dB $\mu$ V. (5) Measure the Pin 8 voltage, that is "VRFAGCMIN" (6) Connect Pin 6 / 7 to GND. (7) Measure the Pin 8 voltage, that is "VRFAGCMAX"
P11	RF AGC Control Range / $\Delta$ ERFAGC	RF AGC : 1 / 63 PIF VCO : adjust Others : Preset	(1) Input a 38.9MHz, 90dB $\mu$ V, non-modulation signal into Pin 6. (2) Adjust PIF VCO so that the AFT voltage is 2.5V. (3) Set RF AGC to 1. (4) Decreasing the IF input level, measure the input level at which the Pin 8 voltage is 4.5V, that is ERFAGCMIN. (5) Set RF AGC to 63. (6) Increasing the IF input level, measure the input level at which the Pin 8 voltage is 4.5V, that is ERFAGCMAX. (7) Calculate ; " $\Delta$ ERFAGC" = ERFAGCMAX - ERFAGCMIN
P12	AFT Center Voltage /VAFTCEN	RF AGC : except 0 Others : Preset	(1) Connect Pin 6 / 7 to GND. (2) Supply 3V to Pin 9. (3) Measure the Pin 4 voltage, that is "VAFTCEN".

NOTE	ITEM / SYMBOL	BUS CONDITION	MEASUREMENT METHOD
P13	AFT Voltage / V <sub>AFTMAX</sub> / V <sub>AFTMIN</sub>	RF AGC : except 0 PIF VCO : adjust Others : Preset	(1) Input a 38.9MHz, 90dB $\mu$ V, 87.5% modulated video signal into Pin 6. (2) Adjust PIF VCO so that the AFT voltage is 2.5V. (3) Input a 37.9MHz, 90dB $\mu$ V, 87.5% modulated video signal into Pin 6. (4) Measure the Pin 4 voltage, that is "V <sub>AFTMAX</sub> " (5) Input a 39.9MHz, 90dB $\mu$ V, 87.5% modulated video signal into Pin 6. (6) Measure the Pin 4 voltage, that is "V <sub>AFTMIN</sub> "
P14	AFT Sensitivity / $\mu$ AFT	RF AGC : except 0 PIF VCO : adjust Others : Preset	(1) Input a 38.9MHz, 90dB $\mu$ V, non-modulation signal into Pin 6. (2) Adjust PIF VCO so that the AFT voltage is 2.5V. (3) When changing the input frequency to $\pm 20$ kHz, measure the change of Pin 4 voltage, that is $\Delta V_{AFT}$ . (4) Calculate ; " $\mu_{AFT}$ " = $40 / \Delta V_{AFT}$
P15	PIF VCO Control Sensitivity / $\beta_{IFVCO}$	RF AGC : except 0 PIF VCO : adjust Others : Preset	(1) Input a 38.9MHz, 90dB $\mu$ V, non-modulation signal into Pin 6. (2) Adjust PIF VCO so that the AFT voltage is 2.5V. (3) Measure the Pin 48 voltage, that is V <sub>LOOP389</sub> . (4) Input a 38.7MHz, 90dB $\mu$ V, non-modulation signal into Pin 6. (5) Measure the Pin 48 voltage, that is V <sub>LOOP387</sub> . (6) Calculate ; " $\beta_{IFVCO}$ " = $0.2 / (V_{LOOP387} - V_{LOOP389})$
P16	PIF VCO Pull-In Range / F <sub>PIFINH</sub> / F <sub>PIFINL</sub>	RF AGC : except 0 PIF VCO : adjust Others : Preset	(1) Input a 45MHz, 90dB $\mu$ V, 87.5% modulated video signal into Pin 6. (2) Adjust PIF VCO so that the AFT voltage is 2.5V. (3) Decreasing the input frequency, measure the frequency at which detected video signal appears on Pin 47, that is "F <sub>PIFINH</sub> " (4) Input a 30MHz, 90dB $\mu$ V, 87.5% modulated video signal into Pin 6. (5) Increasing the input frequency, measure the frequency at which detected video signal appears on Pin 47, that is "F <sub>PIFINL</sub> "

SIF & audio stage (Unless otherwise specified, V<sub>CC</sub> = 9V (3, 17, 28 & 52pin) / 5V (36 & 46pin), Ta = 25°C)

NOTE	ITEM / SYMBOL	BUS CONDITION	MEASUREMENT METHOD
S1	FM Det. Output Level /V <sub>AUAC5P</sub> /V <sub>AUAC4P</sub> /V <sub>AUAC4N</sub>	Audio ATT : 127 Au Gain : 0 / 1 AF-G : 0 / 1 Others : Preset	(1) Input a 5.5MHz, 90dB <sub>μ</sub> V FM signal (Modulate 400Hz with 50kHz deviation) into Pin 53. (2) Measure the output amplitude at Pin 2, that is "V <sub>AUAC5P</sub> ". (Au Gain : 0, AF-G : 0) (3) Input a 4.5MHz, 90dB <sub>μ</sub> V FM signal (Modulate 400Hz with 50kHz deviation) into Pin 53. (4) Measure the output amplitude at Pin 2, that is "V <sub>AUAC4P</sub> ". (Au Gain : 0, AF-G : 0) (5) Input a 4.5MHz, 90dB <sub>μ</sub> V FM signal (Modulate 400Hz with 25kHz deviation) into Pin 53. (6) Measure the output amplitude at Pin 2, that is "V <sub>AUAC4N</sub> ". (Au Gain : 1, AF-G : 1)
S2	Audio Distortion /D <sub>AUDIO</sub>	Audio ATT : 127 Others : Preset	(1) Input a 5.5MHz, 90dB <sub>μ</sub> V FM signal (Modulate 400Hz with 50kHz deviation) into Pin 53. (2) Measure the distortion of Pin 2 output, that is "D <sub>AUDIOP</sub> ". (3) Input a 4.5MHz, 90dB <sub>μ</sub> V FM signal (Modulate 400Hz with 25kHz deviation) into Pin 53. (4) Measure the distortion of Pin 2 output, that is "D <sub>AUDION</sub> ".
S3	Audio S / N /S / N <sub>SIF</sub>	Audio ATT : 127 Others : Preset	(1) Input a 5.5MHz, 90dB <sub>μ</sub> V non-modulation signal into Pin 53. (2) Measure the output amplitude at Pin 2, that is V <sub>NOAUACP</sub> . (3) Calculate ; "S / N <sub>SIFP</sub> " = 20*ℓog (V <sub>AUAC5P</sub> / V <sub>NOAUACP</sub> ) (4) Input a 4.5MHz, 90dB <sub>μ</sub> V non-modulation signal into Pin 53. (5) Measure the output amplitude at Pin 2, that is V <sub>NOAUACN</sub> . (6) Calculate ; "S / N <sub>SIFN</sub> " = 20*ℓog (V <sub>AUAC5P</sub> / V <sub>NOAUACN</sub> )

NOTE	ITEM / SYMBOL	BUS CONDITION	MEASUREMENT METHOD
S4	AMR / AMR	Audio ATT : 127 Others : Preset	(1) Input a 5.5MHz, 90dB $\mu$ V AM signal (Modulate 400Hz with 30%) into Pin 53. (2) Measure the output amplitude at Pin 2, that is $V_{AMAU}$ . (3) Calculate ; "AMR" = $20 \cdot \log (V_{AUAC5P} / V_{AMAU})$
S5	Limiting Sensitivity / ELIM	Audio ATT : 127 Others : Preset	(1) Input a 5.5MHz, 90dB $\mu$ V FM signal (Modulate 400Hz with 50kHz deviation) into Pin 53. (2) Decreasing the input level, measure the input level at which Pin 2 output amplitude turns to be -3dB against $V_{AUAC5P}$ , that is "ELIM".
S6	Band Width (5.5MHz / PAL) / FAUH5P / FAUL5P	Audio ATT : 127 Others : Preset	(1) Input a 5.5MHz, 90dB $\mu$ V FM signal (Modulate 400Hz with 50kHz deviation) into Pin 53. (2) Increasing the input frequency, measure the frequency at which Pin 2 output turns to be -3dB against $V_{AUAC5P}$ , that is "FAUH5P". (2) Decreasing the input frequency, measure the frequency at which Pin 2 output turns to be -3dB against $V_{AUAC5P}$ , that is "FAUL5P".
S7	Band Width (4.5MHz / PAL) / FAUH4N / FAUL4N	Audio ATT : 127 Au Gain : 1 AF-G : 1 Others : Preset	(1) Input a 4.5MHz, 90dB $\mu$ V FM signal (Modulate 400Hz with 25kHz deviation) into Pin 53. (2) Increasing the input frequency, measure the frequency at which Pin 2 output turns to be -3dB against $V_{AUAC4N}$ , that is "FAUH4N". (3) Decreasing the input frequency, measure the frequency at which Pin 2 output turns to be -3dB against $V_{AUAC4N}$ , that is "FAUL4N".



NOTE	ITEM / SYMBOL	BUS CONDITION	MEASUREMENT METHOD
S8	Attenuator Gain /GATTMAX /GATTCEN /GATTMIN	Audio ATT : 0 / 64 / 127 Au SW : 1 Others : Preset	(1) Input a 1MHz, 500mV <sub>rms</sub> signal into Pin 55. (2) Set Audio ATT to 0 / 64 / 127 and measure the Pin 2 output amplitude for each bus data, that is V <sub>ATTMAX</sub> / V <sub>ATTCEN</sub> / V <sub>ATTMIN</sub> . (3) Calculate ; "GATTMAX" = 20 * log (V <sub>ATTMAX</sub> / 500) "GATTCEN" = 20 * log (V <sub>ATTCEN</sub> / 500) "GATTMIN" = 20 * log (V <sub>ATTMIN</sub> / 500)
S9	Offset between TV / Ext. /VAUOFFSET	Audio ATT : 127 Au SW : 0 / 1 Others : Preset	(1) Input a 5.5MHz, 90dB <sub>μV</sub> non-modulation signal into Pin 53. (2) Connect Pin 55 to GND via a 4.7 <sub>μF</sub> capacitor. (3) Switching Au SW to 0 / 1 and measure the change of Pin 2 DC level, that is "VAUOFFSET".
S10	DC Change by Volume /ΔVVOLDC	Audio ATT : 0 / 127 Au SW : 1 Others : Preset	(1) Connect Pin 55 to GND via a 4.7 <sub>μF</sub> capacitor. (2) Switching Audio ATT to 0 / 127 and measure the change of Pin 2 DC level, that is "ΔVVOLDC".

Video stage (Unless otherwise specified,  $V_{CC} = 9V$  (3, 17, 28 & 52pin) /  $5V$  (36 & 46pin),  $T_a = 25^\circ C$ )

NOTE	ITEM / SYMBOL	BUS CONDITION	MEASUREMENT METHOD
V1	TV Input Dynamic Range /DR <sub>TV</sub> External Input Dynamic Range /DR <sub>EXT</sub>	Video SW : 00 / 01 Others : Preset	(1) Input a white signal with sync into Pin 41 & 43. (2) Increasing the input amplitude, measure the amplitude (Include sync) at which the Pin 35 output is clipped, that is "DR <sub>TV</sub> " (Video SW : 00) / "DR <sub>EXT</sub> " (Video SW : 01)
V2	TV Mode Gain /G <sub>TV</sub> Ext. Mode Gain /G <sub>EXT</sub>	Video SW : 00 / 01 Others : Preset	(1) Input a 1V <sub>p-p</sub> , white signal with sync into Pin 41 & 43. (2) Set Video SW to 00 and measure the gain between Pin 43 and Pin 35, that is "G <sub>TV</sub> " (3) Set Video SW to 01 and measure the gain between Pin 41 and Pin 35, that is "G <sub>EXT</sub> "
V3	AV SW Cross-Talk /CT <sub>SWTE</sub> /CT <sub>SWET</sub>	Video SW : 00 / 01 Others : Preset	(1) Input a PAL red signal with sync into Pin 43 and connect Pin 41 to GND via a 1 $\mu$ F capacitor. (2) Set Video SW 01, measure the amplitude of 4.43MHz signal at Pin 35 and calculate the cross-talk, that is "CT <sub>SWTE</sub> ". (3) Input a red signal into Pin 41 and connect Pin 43 to GND via a 1 $\mu$ F capacitor. (4) Set Video SW 00, measure the amplitude of 4.43MHz signal at Pin 35 and calculate the cross-talk, that is "CT <sub>SWET</sub> ".
V4	Y Input Dynamic Range /DR <sub>Y</sub>	Uni-Color : 32 Brightness : 0 Color : 0 Others : Preset	(1) Input a white signal with sync into Pin 43 & 39. (2) Increasing the Pin 39 input amplitude, measure the amplitude (include sync) at which the Pin 18 output is clipped, that is "DR <sub>Y</sub> ".
V5	Y Input Pedestal Clamp Voltage /V <sub>YCLP</sub>	All : Preset	(1) Input a composite sync signal into Pin 43. (2) Connect Pin 39 to GND via a 1 $\mu$ F capacitor. (3) Measure the DC Voltage at Pin 39, that is "V <sub>YCLP</sub> ".
V6	Y Delay Time /t <sub>YDEL</sub>	Uni-Color : 63 Color : 0 Others : Preset	(1) Input a 2T pulse with sync into Pin 43 & 39. (2) Observe the Pin 18 output, measure the delay time between Pin 39 and Pin 18, that is "t <sub>YDEL</sub> ".

NOTE	ITEM / SYMBOL	BUS CONDITION	MEASUREMENT METHOD
V7	Brightness Characteristics /VBRTMAX /VBRTCEN /VBRTMIN Brightness Data Sensitivity /ΔVBRT	Brightness : 0 / 64 / 127 Color : 0 Others : Preset	(1) Input a 0IRE black signal with sync into Pin 43 & 39. (2) Measure the DC level of picture period at Pin 18 for Brightness : 127 / 64 / 0, that is "VBRTMAX" / "VBRTCEN" / "VBRTMIN". (3) Calculate ; "ΔVBRT" = (VBRTMAX - VBRTMIN) / 127
V8	Uni-Color Characteristics for Y /GUCYMAX /GUCYCEN /GUCYMIN	Uni-Color : 0 / 32 / 63 Color : 0 Others : Preset	(1) Input a 50IRE (0.357V) white signal with sync into Pin 43 & 39. (2) Measure the output picture amplitude at Pin 18 for Uni-Color 63 / 32 / 0, that is VUCYMAX / VUCYCEN \ VUCYMIN. (3) Calculate ; "GUCYMAX" = 20*log (VUCYMAX / 0.357) "GUCYCEN" = 20*log (VUCYCEN / 0.357) "GUCYMIN" = 20*log (VUCYMIN / 0.357)
V9	Sub-Contrast Characteristics /GSCONMAX /GSCONMIN	Sub-Contrast : 0 / 8 / 15 Uni-Color : 63 Color : 0 Others : Preset	(1) Input a 50IRE white signal with sync into Pin 43 & 39. (2) Measure the output picture amplitude at Pin 18 for Sub-Contrast 15 / 8 / 0, that is VSCONMAX / VSCONCEN / VSCONMIN. (3) Calculate ; "GSCONMAX" = 20*log (VSCONMAX / VSCONCEN) "GSCONMIN" = 20*log (VSCONMIN / VSCONCEN)
V10	Sharpness Peaking Frequency /FSHP	Sharpness : 63 Uni-Color : 63 Color : 0 Others : Preset	(1) Input a 0.5V <sub>p-p</sub> sweep signal with sync into Pin 43 & 39. (2) Measure the frequency at which the Pin 18 output amplitude is Max., that is "FSHP".
V11	Sharpness Control Characteristics /GSHMAX /GSHCEN /GSHMIN	Sharpness : 0 / 32 / 63 Uni-Color : 63 Color : 0 Others : Preset	(1) Input a 0.5V <sub>p-p</sub> sweep signal with sync into Pin 43 & 39. (2) Measure the output picture amplitude for 100kHz at Pin 18, that is VSH100k. (3) Measure the output picture amplitude for FSHP when Sharpness is max., center and min., that is VSHMAX, VSHCEN and VSHMIN. (4) Calculate ; "GSHMAX" = 20*log (VSHMAX / VSH100k) "GSHCEN" = 20*log (VSHCEN / VSH100k) "GSHMIN" = 20*log (VSHMIN / VSH100k)

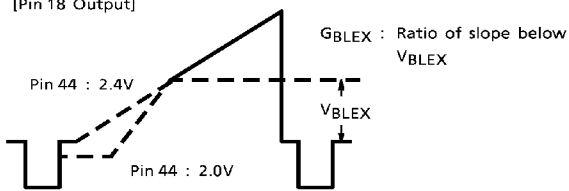
NOTE	ITEM / SYMBOL	BUS CONDITION	MEASUREMENT METHOD
V12	Y Frequency Response /FR <sub>Y</sub>	Uni-Color : 63 Sharpness : Adjust Color : 0 Others : Preset	(1) Input a 0.5V <sub>p-p</sub> sweep signal with sync into Pin 43 & 39. (2) Adjust Sharpness so that the output amplitude for F <sub>SH100k</sub> equals V <sub>SH100k</sub> . (3) Measure the frequency at which the output amplitude is 3dB down against V <sub>SH100k</sub> , which is "FR <sub>Y</sub> ".
V13	Black Expansion Start Point /V <sub>BLEX</sub>	Uni-Color : 63 Color : 0 Others : Preset	(1) Input a 100IRE ramp signal with sync into Pin 43 & 39. (2) Supply 2.4V / 2.0V to Pin 44 and observe the Pin 18 output. (3) Measure "V <sub>BLEX</sub> " and "G <sub>BLEX</sub> ".  [Pin 18 Output] 
	Black Expansion AMP Gain /G <sub>BLEX</sub>		
V14	Black Peak Detection Level /ΔV <sub>BLPD</sub>	Others : Preset	(1) Input a composite sync signal into Pin 43. (2) Increasing the Pin 39 DC level, measure the level at which the Pin 44 voltage drops down, that is V <sub>BLPD</sub> . (3) Calculate ; "ΔV <sub>BLPD</sub> " = V <sub>BLPD</sub> - V <sub>39</sub>
V15	WPS Level /V <sub>WPS</sub>	Uni-Color : 63 Brightness : 127 Color : 0 Others : Preset	(1) Input a 100IRE ramp signal with sync into Pin 43 & 39. (2) Measure the amplitude from cut-off level to peak (At which output signal is clipped), that is "V <sub>WPS</sub> ".
V16	Chroma Trap Gain /G <sub>TRAP 358</sub> , G <sub>TRAP 443</sub>	C-Trap : 0 / 1 Uni-Color : 63 Color : 0 Others : Preset	(1) Input a 0.5V <sub>p-p</sub> , 3.58MHz signal with sync into Pin 43 & 39. (2) Measure the 3.58MHz amplitude at Pin 18 for Chroma Trap : 1 / 0, that is V <sub>TRAPON</sub> / V <sub>TRAPOFF</sub> . (3) Calculate ; "G <sub>TRAP358</sub> " = 20 * log (V <sub>TRAPON</sub> / V <sub>TRAPOFF</sub> ) (4) Input a 0.5V <sub>p-p</sub> , 4.43MHz signal with sync into Pin 43 & 39. (5) Measure the 4.43MHz amplitude at Pin 18 for Chroma Trap : 1 / 0, that is V <sub>TRAPON</sub> / V <sub>TRAPOFF</sub> . (6) Calculate ; "G <sub>TRAP443</sub> " = 20 * log (V <sub>TRAPON</sub> / V <sub>TRAPOFF</sub> )

NOTE	ITEM / SYMBOL	BUS CONDITION	MEASUREMENT METHOD
V17	Half Tone Characteristics for Y /GHTY	Half Tone : 0 / 1 Uni-Color : 63 Color : 0 Others : Preset	(1) Input a 100IRE white signal with sync into Pin 43 & 39. (2) Measure the output picture amplitude at Pin 18 for Half Tone : 1/0, that is $V_{HTYON} /$ $V_{HTYOFF}$ . (3) Calculate ; "GHTY" = $20 \cdot \log (V_{HTYON} / V_{HTYOFF})$

Chrome stage (Unless otherwise specified, V<sub>CC</sub> = 9V (3, 17, 28 & 52pin) / 5V (36 & 46pin), Ta = 25°C)

NOTE	ITEM / SYMBOL	BUS CONDITION	MEASUREMENT METHOD
C1	ACC Characteristics /V <sub>ACCH</sub> /V <sub>ACCL</sub>	Mute : 01 Uni-Color : 63 Others : Preset	(1) Input a 4.43MHz PAL rainbow color-bar (300mV <sub>p-p</sub> , burst : chroma = 1 : 1) with sync into Pin 43. (2) Changing the amplitude of burst and chroma, measure the input amplitude at which Pin 20 output amplitude is +1dB / -1dB against the one for 300mV <sub>p-p</sub> input, that is "V <sub>ACCH</sub> " / "V <sub>ACCL</sub> ".
C2	TOF Characteristics (4.43MHz) /F <sub>0T443</sub> /Q <sub>T443</sub>	TEST : 01000111 C-BPF : 0 / 1 Color : 010 / 101 System : Preset Others : Preset	(1) Set C-BPF to 1 and Color System to 010. (2) Input a sweep signal into Pin 43. (3) Observe the frequency response at Pin 18 and measure the Peaking Frequency / Q of chroma filter, that is "F <sub>0T443</sub> " / "Q <sub>T443</sub> ". (4) Set C-BPF to 0 and Color System to 010 and repeat (2) & (3), that is "F <sub>0B443</sub> " / "Q <sub>B443</sub> ". (5) Set C-BPF to 1 and Color System to 101 and repeat (2) & (3), that is "F <sub>0T358</sub> " / "Q <sub>T358</sub> ". (6) Set C-BPF to 0 and Color System to 101 and repeat (2) & (3), that is "F <sub>0B358</sub> " / "Q <sub>B358</sub> ".
	BPF Characteristics (4.43MHz) /F <sub>0B443</sub> /Q <sub>B443</sub>		
	TOF Characteristics (3.58MHz) /F <sub>0T358</sub> /Q <sub>T358</sub>		
	BPF Characteristics (3.58MHz) /F <sub>0B358</sub> /Q <sub>B358</sub>		
C3	C Delay Time /t <sub>CDEL</sub>	Mute : 01 Uni-Color : 63 Others : Preset	(1) Input a 4.43MHz, PAL rainbow color-bar (300mV <sub>p-p</sub> , burst : chroma = 1 : 1) with sync into Pin 43. (2) Observe the Pin 18 output, measure the delay time between Pin 43 and Pin 18, that is "t <sub>CDEL</sub> ". (3) Calculate ; "Δt <sub>Y / C</sub> " = t <sub>YDEL</sub> - t <sub>CDEL</sub>
	Delay Time Difference between Y / C /Δt <sub>Y / C</sub>		
C4	Color Characteristics /G <sub>COLMAX</sub> /G <sub>COLMIN</sub>	Color : 0 / 64 / 127 Mute : 01 Uni-Color : 63 Others : Preset	(1) Input a 4.43MHz PAL rainbow color-bar (300mV <sub>p-p</sub> , burst : chroma = 1 : 1) with sync into Pin 43. (2) Measure the Pin 18 amplitude for Color 127 / 64 / 0, that is V <sub>COLMAX</sub> / V <sub>COLCEN</sub> / V <sub>COLMIN</sub> . (3) Calculate ; "G <sub>COLMAX</sub> " = 20 * log (V <sub>COLMAX</sub> / V <sub>COLCEN</sub> ) "G <sub>COLMIN</sub> " = 20 * log (V <sub>COLMIN</sub> / V <sub>COLCEN</sub> )

NOTE	ITEM / SYMBOL	BUS CONDITION	MEASUREMENT METHOD
C5	Uni-Color Characteristics for C /GUCC	Uni-Color : 0 / 63 Mute : 01 Others : Preset	(1) Input a 4.43MHz, PAL rainbow color-bar (300mV <sub>p-p</sub> , burst : chroma = 1 : 1) with sync into Pin 43. (2) Measure the Pin 18 amplitude for Uni-Color 63 / 0, that is V <sub>UCCMAX</sub> and V <sub>UCCMIN</sub> . (3) Calculate ; "GUCC" = 20*log (V <sub>UCCMIN</sub> / V <sub>UCCMAX</sub> )
C6	Tint Characteristics (3.58MHz) /Δ θ <sub>358MAX</sub> /Δ θ <sub>358MIN</sub>	Tint : 0 / 64 / 127 Mute : 01 Uni-Color : 63 Others : Preset	(1) Input a 3.58MHz NTSC rainbow color-bar (286mV <sub>p-p</sub> , burst : chroma = 1 : 1) with sync into Pin 43. (2) Set Tint to 64 and adjust the burst phase so that the 6th bar of Pin 20 output is maximum, that is θ <sub>358CEN</sub> . (3) Change Tint to 127 / 0 and adjust the burst phase so that the 6th bar of Pin 20 output is maximum, that is θ <sub>358MAX</sub> / θ <sub>358MIN</sub> . (4) Calculate ; "Δ θ <sub>358MAX</sub> " = -(θ <sub>358MAX</sub> - θ <sub>358CEN</sub> ) "Δ θ <sub>358MIN</sub> " = -(θ <sub>358MIN</sub> - θ <sub>358CEN</sub> ) (5) Input a 4.43MHz NTSC rainbow color-bar (286mV <sub>p-p</sub> , burst : chroma = 1 : 1) with sync into Pin 43 and repeat (2) & (3), that is θ <sub>443CEN</sub> / θ <sub>443MAX</sub> / θ <sub>443MIN</sub> . (6) Calculate ; "Δ θ <sub>443MAX</sub> " = -(θ <sub>443MAX</sub> - θ <sub>443CEN</sub> ) "Δ θ <sub>443MIN</sub> " = -(θ <sub>443MIN</sub> - θ <sub>443CEN</sub> )
	Tint Characteristics (4.43MHz) /Δ θ <sub>443MAX</sub> /Δ θ <sub>443MIN</sub>		
C7	Relative Amplitude (PAL) /V <sub>PR</sub> / B /V <sub>PG</sub> / B	Mute : 01 Uni-Color : 63 Others : Preset	(1) Input a 4.43MHz, PAL rainbow color-bar (300mV <sub>p-p</sub> , burst : chroma = 1 : 1) with sync into Pin 43. (2) Measure the amplitude of Pin 18 / 19 / 20 output, that is "V <sub>PROUT</sub> " / "V <sub>PGOUT</sub> " / "V <sub>PBOUT</sub> ". (3) Calculate ; "V <sub>PR</sub> / B" = V <sub>PROUT</sub> / V <sub>PBOUT</sub> "V <sub>PG</sub> / B" = V <sub>PGOUT</sub> / V <sub>PBOUT</sub> (4) Input a 3.58MHz NTSC rainbow color-bar (286mV <sub>p-p</sub> , burst : chroma = 1 : 1) with sync into Pin 43, then repeat (2), that is V <sub>NROUT</sub> / V <sub>NGOUT</sub> / V <sub>NBOUT</sub> . (5) Calculate ; "V <sub>NR</sub> / B" = V <sub>NROUT</sub> / V <sub>NBOUT</sub> "V <sub>NG</sub> / B" = V <sub>NGOUT</sub> / V <sub>NBOUT</sub>
	Relative Amplitude (NTSC) /V <sub>NR</sub> / B /V <sub>NG</sub> / B		

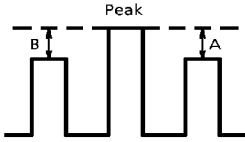
NOTE	ITEM / SYMBOL	BUS CONDITION	MEASUREMENT METHOD
C8	Relative Phase (PAL) / $\theta_{PR-B}$ / $\theta_{PG-B}$	Mute : 01 Uni-Color : 63 Others : Preset	(1) Input a 4.43MHz PAL rainbow color-bar (300mV <sub>p-p</sub> , burst : chroma = 1 : 1) with sync into Pin 43. (2) Observe the Pin 18 / 19 / 20 output, measure the R / G / B modulation angle ( $\theta_{PR}$ / $\theta_{PG}$ / $\theta_{PB}$ ) according following figure and equality. $\theta_{p*} = \theta_{0*} - \left\{ \tan^{-1} \left( \frac{1}{\frac{2A}{B} + \sqrt{3}} \right) - 15 \right\}$  <p>For <math>\theta_{PR}</math> ; Peak : 3rd bar, <math>\theta_{0R} = 90</math>                      For <math>\theta_{PG}</math> ; Peak (Negative) : 4th bar, <math>\theta_{0G} = 240</math>                      For <math>\theta_{PB}</math> ; Peak : 6th bar, <math>\theta_{0B} = 0</math></p> (3) Calculate ; " $\theta_{PR-B}$ " = $\theta_{PR} - \theta_{PB}$ " $\theta_{PG-B}$ " = $\theta_{PG} - \theta_{PB}$ (4) Input a 3.58MHz NTSC rainbow color-bar (286mV <sub>p-p</sub> , burst : chroma = 1 : 1) with sync into Pin 43, then repeat (2), that is $\theta_{NR}$ / $\theta_{NG}$ / $\theta_{NB}$ . (5) Calculate ; " $\theta_{NR-B}$ " = $\theta_{NR} - \theta_{NB}$ " $\theta_{NG-B}$ " = $\theta_{NG} - \theta_{NB}$
	Relative Phase (NTSC) / $\theta_{NR-B}$ / $\theta_{NG-B}$		



NOTE	ITEM / SYMBOL	BUS CONDITION	MEASUREMENT METHOD
C9	APC Pull-In Range (4.43MHz) / $\Delta F_{4APCP+}$ / $\Delta F_{4APCP-}$	Color System : 010 / 101 Others : Preset	(1) Input a 4.43MHz PAL rainbow color-bar (300mV <sub>p-p</sub> , burst : chroma = 1 : 1) with sync into Pin 43. (2) Set Color System to 010 (443PAL). (3) For higher frequency than 4.43MHz, measure the burst frequency at which Pin 29 DC level changes from low to high / from high to low, that is $F_{4APCP+} / F_{4APCH+}$ . (4) For lower frequency than 4.43MHz, repeat (2), that is $F_{4APCP-} / F_{4APCH-}$ . (5) Calculate ; $"\Delta F_{4APCP+}" = F_{4APCP+} - 4433619$ $"\Delta F_{4APCP-}" = 4433619 - F_{4APCP-}$ $"\Delta F_{4APCH+}" = F_{4APCH+} - 4433619$ $"\Delta F_{4APCH-}" = 4433619 - F_{4APCH-}$ (6) Input a 3.58MHz NTSC rainbow color-bar (286mV <sub>p-p</sub> , burst : chroma = 1 : 1) with sync into Pin 43. (7) Set Color System to 101 (358NTSC). (8) For higher frequency than 3.58MHz, repeat (2), that is $F_{3APCP+} / F_{3APCH+}$ . (9) For lower frequency than 3.58MHz, repeat (2), that is $F_{3APCP-} / F_{3APCH-}$ . (10) Calculate ; $"\Delta F_{3APCP+}" = F_{3APCP+} - 3579545$ $"\Delta F_{3APCP-}" = 3579545 - F_{3APCP-}$ $"\Delta F_{3APCH+}" = F_{3APCH+} - 3579545$ $"\Delta F_{3APCH-}" = 3579545 - F_{3APCH-}$
	APC Hold Range (4.43MHz) / $\Delta F_{4APCH+}$ / $\Delta F_{4APCH-}$		
	APC Pull-In Range (3.58MHz) / $\Delta F_{3APCP+}$ / $\Delta F_{3APCP-}$		
	APC Hold Range (3.58MHz) / $\Delta F_{3APCH+}$ / $\Delta F_{3APCH-}$		

NOTE	ITEM / SYMBOL	BUS CONDITION	MEASUREMENT METHOD
C10	APC Control Sensitivity (4.43MHz) / $\beta_{443}$	Color System : 010 / 101 Others : Preset	(1) Connect Pin 43 to GND via a 1 $\mu$ F capacitor. (2) Set Color System to 010 (443PAL). (3) Adjust Pin 10 voltage so that the Pin 29 output frequency is 4.433619MHz, that is $V_{4APCCEN}$ . (4) Measure the Pin 29 output frequency when Pin 10 voltage is $V_{4APCCEN} + 100mV / V_{4APCCEN} - 100mV$ , that is $F_{4APC+} / F_{4APC-}$ . (5) Calculate ; $\beta_{443} = (F_{4APC+} - F_{4APC-}) / 200$ (6) Set Color System to 101 (358NTSC). (7) Adjust Pin 10 voltage so that the Pin 29 output frequency is 3.579545MHz, that is $V_{3APCCEN}$ . (8) Measure the Pin 29 output frequency when Pin 10 voltage is $V_{3APCCEN} + 100mV / V_{3APCCEN} - 100mV$ , that is $F_{3APC+} / F_{3APC-}$ . (9) Calculate ; $\beta_{358} = (F_{3APC+} - F_{3APC-}) / 200$
	APC Control Sensitivity (3.58MHz) / $\beta_{358}$		
C11	PAL ID Sensitivity (Normal Mode) / $V_{PALIDON}$ / $V_{PALIDOFF}$	ID SW : 0 / 1 Color System : 010 / 101 Mute : 01 Uni-Color : 63 Others : Preset	(1) Set ID SW to 0. (2) Set Color System to 010 (443PAL). (3) Input a 4.43MHz PAL rainbow color-bar (300mV <sub>p-p</sub> , burst : chroma = 1 : 1) with sync into Pin 43. (4) Measure the burst amplitude at which Pin 29 DC level changes from low to high / from high to low, that is " $V_{PALIDON}$ " / " $V_{PALIDOFF}$ ". (5) Set Color System to 101 (358NTSC). (6) Input a 3.58MHz NTSC rainbow color-bar (286mV <sub>p-p</sub> , burst : chroma = 1 : 1) with sync into Pin 43, and repeat (3), that is " $V_{NTIDON}$ " / " $V_{NTIDOFF}$ ". (7) Set ID SW to 1, repeat (2) ~ (6), that is " $V_{PALIDLON}$ ", " $V_{PALIDLOFF}$ ", " $V_{NTIDLON}$ ", " $V_{NTIDLOFF}$ ".
	PAL ID Sensitivity (Low Mode) / $V_{PALIDLON}$ / $V_{PALIDLOFF}$		
	NTSC ID Sensitivity (Normal Mode) / $V_{NTIDON}$ / $V_{NTIDOFF}$		
	NTSC ID Sensitivity (Low Mode) / $V_{NTIDLON}$ / $V_{NTIDLOFF}$		

NOTE	ITEM / SYMBOL	BUS CONDITION	MEASUREMENT METHOD
C12	ID Output Level /VIDH /VIDL	All : Preset	(1) Input a 4.43MHz PAL color-bar (300mV <sub>p-p</sub> , burst : chroma = 1 : 1) with sync into Pin 43. (2) Measure the center DC level of Pin 29 output, that is "VIDH". (3) Connect Pin 43 to GND via a 1 $\mu$ F capacitor and repeat (2), that is "VIDL".
C13	SECAM ID Det. Current /ISECAM	All : Preset	(1) Input a 4.43MHz NTSC color-bar with sync into Pin 43. (2) Connect Pin 37 / 38 to GND via a 0.1 $\mu$ F capacitor. (3) Pulling the current out of Pin 29, measure the current at which a demodulated output signal disappears at Pin 20, that is "ISECAM".
C14	SECAM ID Det. Current (Strong) /ISECAM-S	All : Preset	(1) Input a PAL color-bar with sync into Pin 43. (2) Connect Pin 37 / 38 to GND via a 0.1 $\mu$ F capacitor. (3) Pulling the current out of Pin 29, measure the current at which a demodulated output signal disappears at Pin 20, that is "ISECAM-S".
C15	fsc Continuous Wave Output Level /VCW	CW SW : 1 Others : Preset	Measure the amplitude of Pin 29 output, that is "VCW".
C16	Sub-Carrier Remain on RGB Output /VSCR /VSCG /VSCB	Mute : 01 Uni-Color : 63 Others : Preset	(1) Input a 4.43MHz PAL rainbow color-bar (300mV <sub>p-p</sub> , burst : chroma = 1 : 1) with sync into Pin 43. (2) Measure the amplitude of 4.43MHz signal at Pin 18 / 19 / 20, that is "VSCR" / "VSCG" / "VSCB".
C17	Half Tone Characteristics for C /GHTC	Half Tone : 1 Mute : 01 Uni-Color : 63 Others : Preset	(1) Input a 4.43MHz PAL rainbow color-bar (300mV <sub>p-p</sub> , burst : chroma = 1 : 1) with sync into Pin 43. (2) Set Half Tone to 1 and measure the amplitude of Pin 20 output, that is V <sub>PBHTC</sub> . (3) Calculate ; "GHTC" = 20 * log (V <sub>PBHTC</sub> / V <sub>PBOUT</sub> )

Text stage (Unless otherwise specified,  $V_{CC} = 9V$  (3, 17, 28 & 52pin) /  $5V$  (36 & 46pin),  $T_a = 25^\circ C$ )

NOTE	ITEM / SYMBOL	BUS CONDITION	MEASUREMENT METHOD
T1	V-BLK Pulse Output Level / $V_{VBLK}$ H-BLK Pulse Output Level / $V_{HBLK}$	All : Preset	(1) Input a composite sync signal into Pin 43. (2) Measure the DC level of V/H blanking period at Pin 20, that is " $V_{VBLK}$ " / " $V_{HBLK}$ ".
T2	RGB Output Black Level (0IRE DC) / $V_{BLACK}$	Color : 0 Others : Preset	(1) Input a 0IRE Y signal with sync into Pin 43 & 39. (2) Measure the DC level of picture period at Pin 20, that is " $V_{BLACK}$ ".
T3	RGB Output White Level (100IRE AC) / $V_{WHITE}$	Uni-Color : 63 Color : 0 Others : Preset	(1) Input a 100IRE Y signal with sync into Pin 43 & 39. (2) Measure the amplitude from 0 to 100IRE at Pin 20, that is " $V_{WHITE}$ ".
T4	Cut-Off Voltage Variable Range / $\Delta V_{CUT+}$ / $\Delta V_{CUT-}$	B Cut Off : 0 / 255 Color : 0 Others : Preset	(1) Input a 0IRE Y signal with sync into Pin 43 & 39. (2) Measure the DC level of picture period at Pin 20 for B Cut-off : 255 / 0, that is $V_{CUTMAX} / V_{CUTMIN}$ . (3) Calculate ; " $\Delta V_{CUT+}$ " = $V_{CUTMAX} - V_{BLACK}$ " $\Delta V_{CUT-}$ " = $V_{CUTMIN} - V_{BLACK}$
T5	Drive Control Variable Range / $G_{DR+}$ / $G_{DR-}$	B Drive : 0 / 127 Uni-Color : 63 Color : 0 Others : Preset	(1) Input a 100IRE Y signal with sync into Pin 43 & 39. (2) Measure the amplitude from 0 to 100IRE at Pin20 for B drive 127 / 0, that is $V_{DRMAX} / V_{DRMIN}$ . (3) Calculate ; " $G_{DR+}$ " = $20 * \log (V_{DRMAX} / V_{WHITE})$ " $G_{DR-}$ " = $20 * \log (V_{DRMIN} / V_{WHITE})$
T6	ABCL Control Voltage Range / $V_{ABCLH}$ / $V_{ABCLL}$ ACL Gain / $G_{ACL}$	ABL Gain : 11 Uni-Color : 63 Color : 0 Others : Preset	(1) Input a 100IRE Y signal with sync into Pin 43 & 39. (2) Decreasing the Pin 21 voltage, measure the voltage at which Pin 20 output begins/ stops decreasing, that is $V_{ABCLH}$ / " $V_{ABCLL}$ ". (3) Measure the minimum amplitude of Pin 20 output, that is $V_{ACLMIN}$ . (4) Calculate ; " $G_{ACL}$ " = $20 * \log (V_{ACLMIN} / V_{WHITE})$

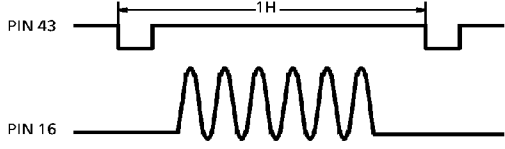
NOTE	ITEM / SYMBOL	BUS CONDITION	MEASUREMENT METHOD
T7	ABL Start Point /VABLP0 /VABLP1 /VABLP2 /VABLP3	ABL Start Point : 00 / 01 / 10 / 11 ABL Gain : 11 Uni-Color : 63 Color : 0 Others : Preset	(1) Input a 0IRE Y signal with sync into Pin 43 & 39. (2) For ABL Point 00 / 01 / 10 / 11, decreasing the Pin 21 voltage, measure the voltage the voltage at which Pin 20 output begins decreasing, that is VABL1 / VABL2 / VABL3 / VABL4. (3) Calculate ; "VABLP0" = VABL1 - VABCLH "VABLP1" = VABL2 - VABCLH "VABLP2" = VABL3 - VABCLH "VABLP3" = VABL4 - VABCLH
T8	ABL Gain /VABLG0 /VABLG1 /VABLG2 /VABLG3	ABL Gain : 00 / 01 / 10 / 11 Uni-Color : 63 Color : 0 Others : Preset	(1) Input a 0IRE Y signal with sync into Pin 43 & 39. (2) For ABL Gain 00 / 01 / 10 / 11, measure the DC level of picture period at Pin 20 when Pin 21 voltage is VABCLL, that is VABL5 / VABL6 / VABL7 / VABL8. (3) Calculate ; "VABLG0" = VABL5 - VBLACK "VABLG1" = VABL6 - VBLACK "VABLG2" = VABL7 - VBLACK "VABLG3" = VABL8 - VBLACK
T9	Analog RGB Dynamic Range /DR <sub>TX</sub>	RGB Contrast : 32 Others : Preset	(1) Input a composite sync signal into Pin 43. (2) Supply 2V to Pin 13. (3) Input a signal of following figure into Pin 16.  (4) Increasing the amplitude of Pin 16 input, measure the amplitude at which the Pin 20 amplitude stops increasing, that is "DR <sub>TX</sub> ".

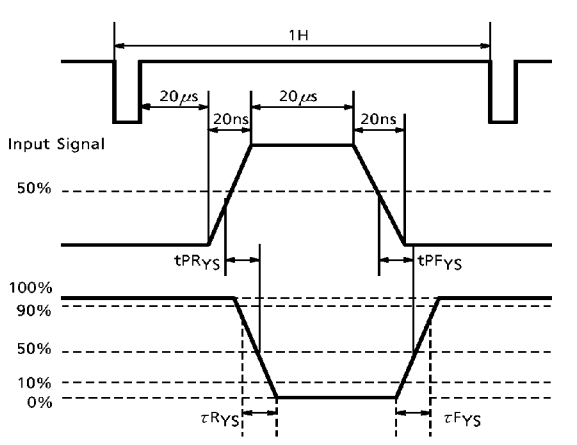
NOTE	ITEM / SYMBOL	BUS CONDITION	MEASUREMENT METHOD
T10	Analog RGB Contrast Control Characteristic / GTXCMAX / GTXCCEN / GTXCMIN	RGB Contrast : 32 Others : Preset	(1) Input a composite sync signal into Pin 43. (2) Supply 2V to Pin 13. (3) Input a signal of NOTE : T <sub>g</sub> figure into Pin 16. (4) For RGB Contrast 63 / 32 / 0, measure the amplitude of Pin 20 output, that is V <sub>TXCMAX</sub> / V <sub>TXCCEN</sub> / V <sub>TXCMIN</sub> . (5) Calculate ; "GTXCMAX" = 20 * log (V <sub>TXCMAX</sub> / 0.2) "GTXCCEN" = 20 * log (V <sub>TXCCEN</sub> / 0.2) "GTXCMIN" = 20 * log (V <sub>TXCMIN</sub> / 0.2)
T11	Analog RGB Brightness Control Characteristic / VTXBRMAX / VTXBRCEN / VTXBRMIN	Brightness : 0 / 64 / 127 Others : Preset	(1) Supply 2V to Pin 13. (2) Connect Pin 16 to GND via a 0.1 μF capacitor. (3) For Brightness 127 / 64 / 0, measure the DC level of picture period at Pin 20, that is "VTXBRMAX" / "VTXBRCEN" / "VTXBRMIN".
T12	Analog RGB Mode Switching Level / V <sub>YS</sub>	RGB Contrast : 32 Others : Preset	(1) Input a composite sync signal into Pin 43. (2) Input a signal of NOTE : T <sub>g</sub> figure into Pin 16. (3) Increasing the Pin 13 voltage, measure the voltage at which the signal inputted into Pin 16 appears at Pin 20, that is "V <sub>YS</sub> ".
T13	Analog RGB Mode Transfer Characteristic / τ <sub>RY<sub>S</sub></sub> / t <sub>PR<sub>Y<sub>S</sub></sub></sub> / τ <sub>F<sub>Y<sub>S</sub></sub></sub> / t <sub>PF<sub>Y<sub>S</sub></sub></sub>	All : Preset	(1) Input a 50IRE Y signal with sync into Pin 43 & 39. (2) Connect Pin 16 to GND via a 0.1 μF capacitor. (3) According to following figure, measure the Analog RGB Mode Transfer Characteristic 

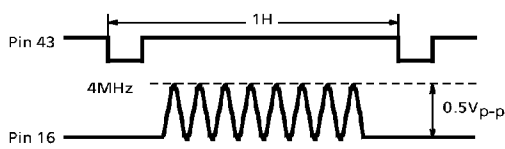
NOTE	ITEM / SYMBOL	BUS CONDITION	MEASUREMENT METHOD
T14	Cross Talk from Analog RGB to TV / CTTX-TV	Uni-Color : 63 RGB Contrast : 63 Others : Preset	(1) Input a composite sync signal into Pin 43. (2) Connect Pin 39 to GND via a 1 $\mu$ F capacitor. (3) Input a signal of following figure into Pin 16.  (4) Measure the amplitude of 4MHz signal at Pin 20, that is V <sub>TX-TV</sub> . (5) Calculate ; "CTTX-TV" = 20*log (V <sub>TX-TV</sub> / 0.5)
T15	Cross Talk from TV to Analog RGB / CTTV-TX	Uni-Color : 63 RGB Contrast : 63 Others : Preset	(1) Input a 4MHz, 0.5V <sub>p-p</sub> Y signal with sync into Pin 43 & 39. (2) Connect Pin 16 to GND via a 0.1 $\mu$ F capacitor. (3) Supply 2V to Pin 13. (4) Measure the amplitude of 4MHz signal at Pin 20, that is V <sub>TV-TX</sub> . (5) Calculate ; "CTTV-TX" = 20*log (V <sub>TV-TX</sub> / 0.5)
T20	SECAM Black Level Adj. Characteristics / V <sub>SECBMAX</sub> / V <sub>SECRMAX</sub> / V <sub>SECBMIN</sub> / V <sub>SECRMIN</sub> SECAM Black Level Adj. Data Sensitivity / $\Delta$ V <sub>SECB</sub> / $\Delta$ V <sub>SECR</sub>	Color System : 111 B-Y Black Adj : 0 / 8 / 15 R-Y Black Adj : 0 / 8 / 15	(1) Connect Pin 29 to GND via a 5.1k $\Omega$ resistor. (2) For B-Y / R-Y Black Adj. : 8, measure the DC level of picture period at Pin 20 / 18, that is V <sub>SECB</sub> CEN / V <sub>SECR</sub> CEN. (3) For B-Y Black Adj. : 0 / 15, measure the DC level change of picture period against V <sub>SECB</sub> CEN at Pin 20, that is "V <sub>SECB</sub> MIN" / "V <sub>SECB</sub> MAX". (4) For R-Y Black Adj. : 0 / 15, measure the DC level change of picture period against V <sub>SECR</sub> CEN at Pin 18, that is "V <sub>SECR</sub> MIN" / "V <sub>SECR</sub> MAX". (5) Calculate ; " $\Delta$ V <sub>SECB</sub> " = (V <sub>SECB</sub> MAX - V <sub>SECB</sub> MIN) / 16 " $\Delta$ V <sub>SECR</sub> " = (V <sub>SECR</sub> MAX - V <sub>SECR</sub> MIN) / 16

DEF stage (Unless otherwise specified,  $V_{CC} = 9V$  (3, 17, 28 & 52pin) /  $5V$  (36 & 46pin),  $T_a = 25^{\circ}C$ )

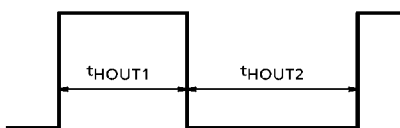
NOTE	ITEM / SYMBOL	BUS CONDITION	MEASUREMENT METHOD
D1	AFC Inactive Period / $T_{50AFCOFF}$ / $T_{60AFCOFF}$	All : Preset	(1) Input a 50Hz / 60Hz composite sync signal into Pin 43. (2) Measure " $T_{50AFCOFF}$ " / " $T_{60AFCOFF}$ " at Pin 40. (cf. Fig.D1)
D2	H-OUT Start Voltage / $V_{HON}$	All : Preset	(1) Let Pin 3 / 17 / 52 / 36 / 46 be open. (2) Increasing Pin 28 voltage, measure the voltage at which H OUT pulse appears at Pin 32, that is " $V_{HON}$ ".
D3	H-OUT Pulse Duty / $W_{HOUT}$	All : Preset	(1) Measure $t_{HOUT1}$ & $t_{HOUT2}$ at Pin 32.  (2) Calculate ; $W_{HOUT} = t_{HOUT1} / (t_{HOUT1} + t_{HOUT2}) * 100$
D4	H-OUT Freq. on AFC Stop Mode / $F_{HAFCOFF}$	AFC Gain : 11 Others : Preset	(1) Input a 50Hz composite sync signal into Pin 43. (2) Measure the H OUT frequency at Pin 32, that is " $F_{HAFCOFF}$ ".
D5	Horizontal Free-Run Frequency / $F_{H50FR}$ / $F_{H60FR}$	V-Freq : 10 / 11 Others : Preset	For V-Freq 10 / 11, measure the H OUT frequency at Pin 32, that is " $F_{H50FR}$ " / " $F_{H60FR}$ ".
D6	Horizontal Freq. Variable Range / $F_{HMAX}$ / $F_{HMIN}$	All : Preset	(1) Connect Pin 40 to $V_{CC}$ via a $10k\Omega$ and measure the H OUT frequency at Pin 32, that is " $F_{HMAX}$ ". (2) Connect Pin 40 to GND via a $68k\Omega$ and measure the H OUT frequency at Pin 32, that is " $F_{HMIN}$ ".
D7	Horizontal Freq. Control Sensitivity / $\beta_{HAFC}$	All : Preset	(1) Measure the Pin 40 voltage at which H OUT frequency is 15.734kHz, that is $V_{H15734}$ . (2) Measure the H OUT frequency when Pin 40 voltage is $V_{H15734} + 50mV$ / $V_{H15734} - 50mV$ , that is $F_{HHIGH}$ / $F_{HLOW}$ . (3) Calculate ; $\beta_{HAFC} = (F_{HHIGH} - F_{HLOW}) / 100$

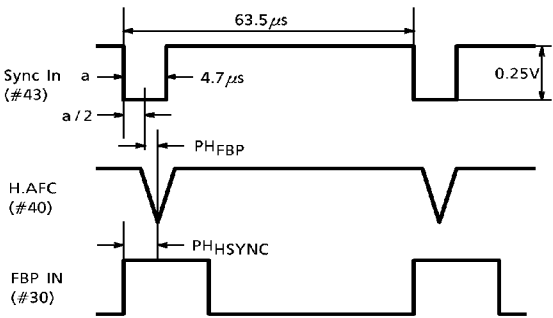

NOTE	ITEM / SYMBOL	BUS CONDITION	MEASUREMENT METHOD
D8	Horizontal Pull-in Range / $\Delta F_{HPH}$ / $\Delta F_{HPL}$	All : Preset	(1) Input a composite sync signal into Pin 43. (2) Decreasing the horizontal frequency from 17kHz, measure the frequency at which H OUT synchronized with Sync Out (Pin 31), that is $F_{HPH}$ . (3) Increasing the horizontal frequency from 14kHz, measure the frequency at which H OUT synchronized with Sync Out (Pin 31), that is $F_{HPL}$ . (4) Calculate ; $\Delta F_{HPH} = F_{HPH} - 15734$ $\Delta F_{HPL} = 15625 - F_{HPL}$
D9	H-OUT Voltage / $V_{HOUTH}$ / $V_{HOUTL}$	All : Preset	(1) Measure the high level of H OUT at Pin 32, that is " $V_{HOUTH}$ ". (2) Measure the Low level of H OUT at Pin 32, that is " $V_{HOUTL}$ ".
D10	Horizontal Freq. Dependence on $V_{CC}$ / $\Delta F_{HVCC}$	All : Preset	(1) Measure the H OUT frequency when H $V_{CC}$ is 8.5V / 9.5V, that is $F_{HVCCH}$ / $F_{HVCCL}$ . (2) Calculate ; $\Delta F_{HVCC} = (F_{HVCCH} - F_{HVCCL}) / 1$
D11	FBP Phase / $PH_{FBP}$  H-Sync. Phase / $PH_{HSYNC}$	All : Preset	(1) Input a composite sync signal into Pin 43. (2) According to the following figure, measure " $PH_{FBP}$ " & " $PH_{HSYNC}$ ".  

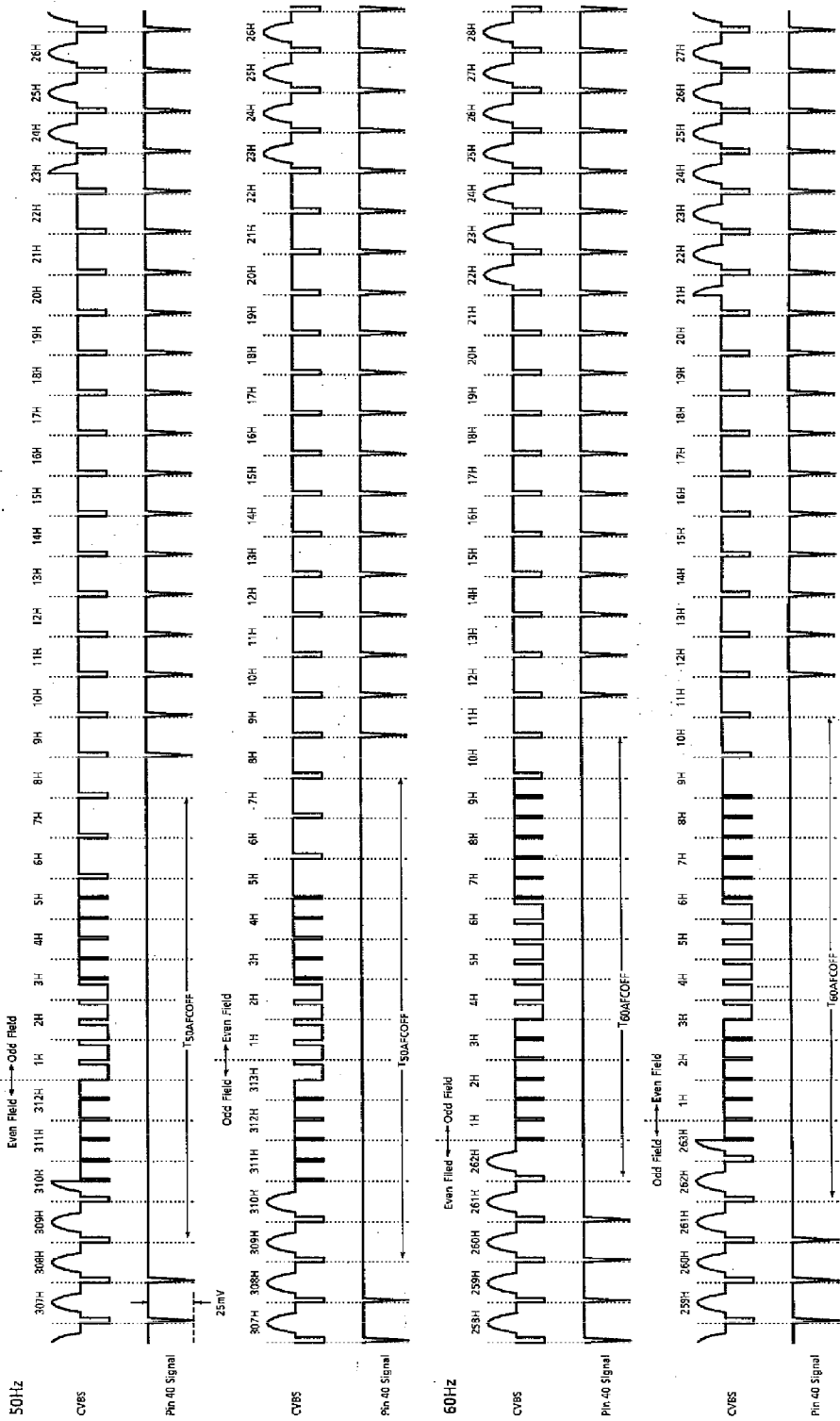
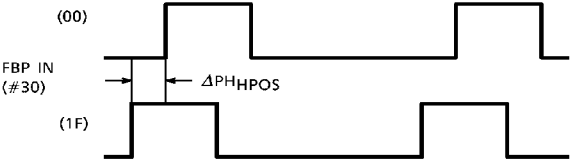
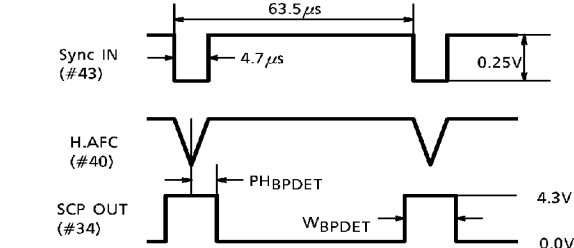
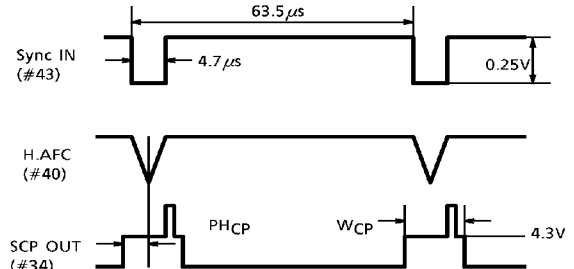
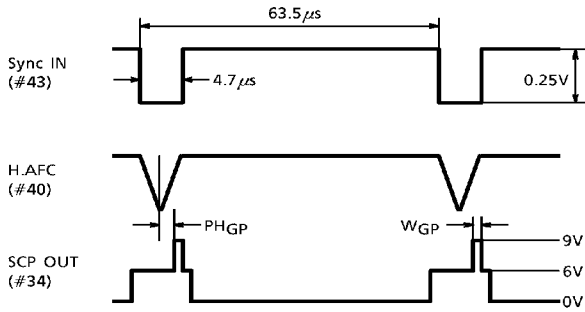
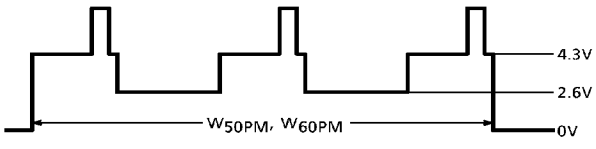

Fig. D1

TB1238N - 66

NOTE	ITEM / SYMBOL	BUS CONDITION	MEASUREMENT METHOD
D12	Horizontal Position Variable Range / $\Delta PH_{HPOS}$	H Position : 0/31 Others : Preset	<p>(1) Input a composite sync signal into Pin 43. (2) Changing Horizontal Position from 0 to 31, measure "<math>\Delta PH_{HPOS}</math>" according to the following figure.</p> 
D13	AFC-2 Pulse Threshold Level / $V_{AFC2}$	All : Preset	<p>(1) Input a composite sync signal into Pin 43. (2) Decreasing the FBP high level, measure the DC level at which H OUT phase changes against Sync Out phase, that is "<math>V_{AFC2}</math>".</p>
D14	H-BLK Pulse Threshold Level / $V_{HBLK}$	All : Preset	<p>(1) Input a composite sync signal into Pin 43. (2) Increasing the FBP high level, measure the DC level at which H blanking begins to work, that is "<math>V_{HBLK}</math>".</p>
D15	Black Peak Det. Stop Period (H) / $PH_{BPDET}$ / $W_{BPDET}$	TEST : 00001000 Others : Preset	<p>(1) Input a composite sync signal into Pin 43. (2) According to the following figure, measure "<math>PH_{BPDET}</math>" &amp; "<math>W_{BPDET}</math>".</p> 
D16	Clamp Pulse Start Phase / $PH_{CP}$	TEST : 00001000 V Position : 001 Others : Preset	<p>(1) Input a composite sync signal into Pin 43. (2) According to the following figure, measure "<math>PH_{CP}</math>" &amp; "<math>W_{CP}</math>".</p> 
	Clamp Pulse Width / $W_{CP}$		

NOTE	ITEM / SYMBOL	BUS CONDITION	MEASUREMENT METHOD
D17	Gate Pulse Start Phase / PHGP	All : Preset	<p>(1) Input a composite sync signal into Pin 43.                      (2) According to the following figure, measure "PHGP" &amp; "WGP".</p> 
	Gate Pulse Width / WGP		<p>(1) Input a composite sync signal into Pin 43.                      (2) Measure the DC voltage of Sync Out low level, that is "V<sub>SYNCL</sub>".</p>
D18	Sync. Output Low Level / V <sub>SYNCL</sub>	All : Preset	<p>(1) Let Pin 3 / 17 / 52 / 36 / 46 be open.                      (2) Increasing Pin 28 voltage, measure the voltage at which V Ramp signal appears at Pin 22, that is "V<sub>VON</sub>".</p>
D19	Vertical Oscillation Start Voltage / V <sub>VON</sub>	All : Preset	<p>(1) Input a 50Hz / 60Hz composite sync signal into Pin 43.                      (2) Measure "T<sub>50GPM</sub>" / "T<sub>60GPM</sub>" at Pin 34. (cf. Fig.D21)</p>
D20	Vertical Free-Run Frequency / F <sub>VAUFR</sub> / F <sub>V60FR</sub>	V-Freq : 00 / 01 Others : Preset	<p>For V-Freq 00 / 01, measure the frequency of V Ramp at Pin 22, that is "F<sub>VAUFR</sub>" / "F<sub>V60FR</sub>".</p>
D21	Gate Pulse V-Masking Period / T <sub>50GPM</sub> / T <sub>60GPM</sub>	All : Preset	<p>Measure the DC level of Pin 22, that is "V<sub>NOVRAMP</sub>".</p>
D22	V.Ramp DC on Service Mode / V <sub>NOVRAMP</sub>	MUTE : 11 Others : Preset	

NOTE	ITEM / SYMBOL	BUS CONDITION	MEASUREMENT METHOD
D23	Vertical Pull-in Range (Auto) / FVPAUL / FVPAUH <hr/> Vertical Pull-In Range (60Hz) / FVP60L / FVP60H	V-Freq : 00 / 01 Others : Preset	(1) Input a composite sync signal into Pin 43. (2) For V-Freq 00 / 01, increasing the input vertical period from 220H by 0.5H step, measure the period at which V OUT signal synchronized with Sync out, that is "FVPAUL" / "FVP60L". (3) For V-Freq 00 / 01, decreasing the input vertical period from 360H by 0.5H step, measure the period at which V OUT signal synchronized with Sync out, that is "FVPAUL" / "FVP60L".
D24	Vertical Period on Fixed Mode / TV313 / TV263	V-Freq : 10 / 11 Others : Preset	For V-Freq 10 / 11, measure the vertical period at Pin 34, that is "TV263" / "TV313".
D25	V-BLK Start Phase / PH50VBLK / PH60VBLK <hr/> V-BLK Width / W50VBLK / W60VBLK	All : Preset	(1) Input a 50Hz / 60Hz composite sync signal into Pin 43. (2) Measure "T50AFCOFF" / "T60AFCOFF" at Pin 40. (cf. Fig.D25)
D26	Picture Mute Period / W50PM / W60PM	TEST : 00001000 Others : Preset	(1) Input a 50Hz / 60Hz composite sync signal into Pin 43. (2) According to a following figure, measure "W50PM" / "W60PM". 

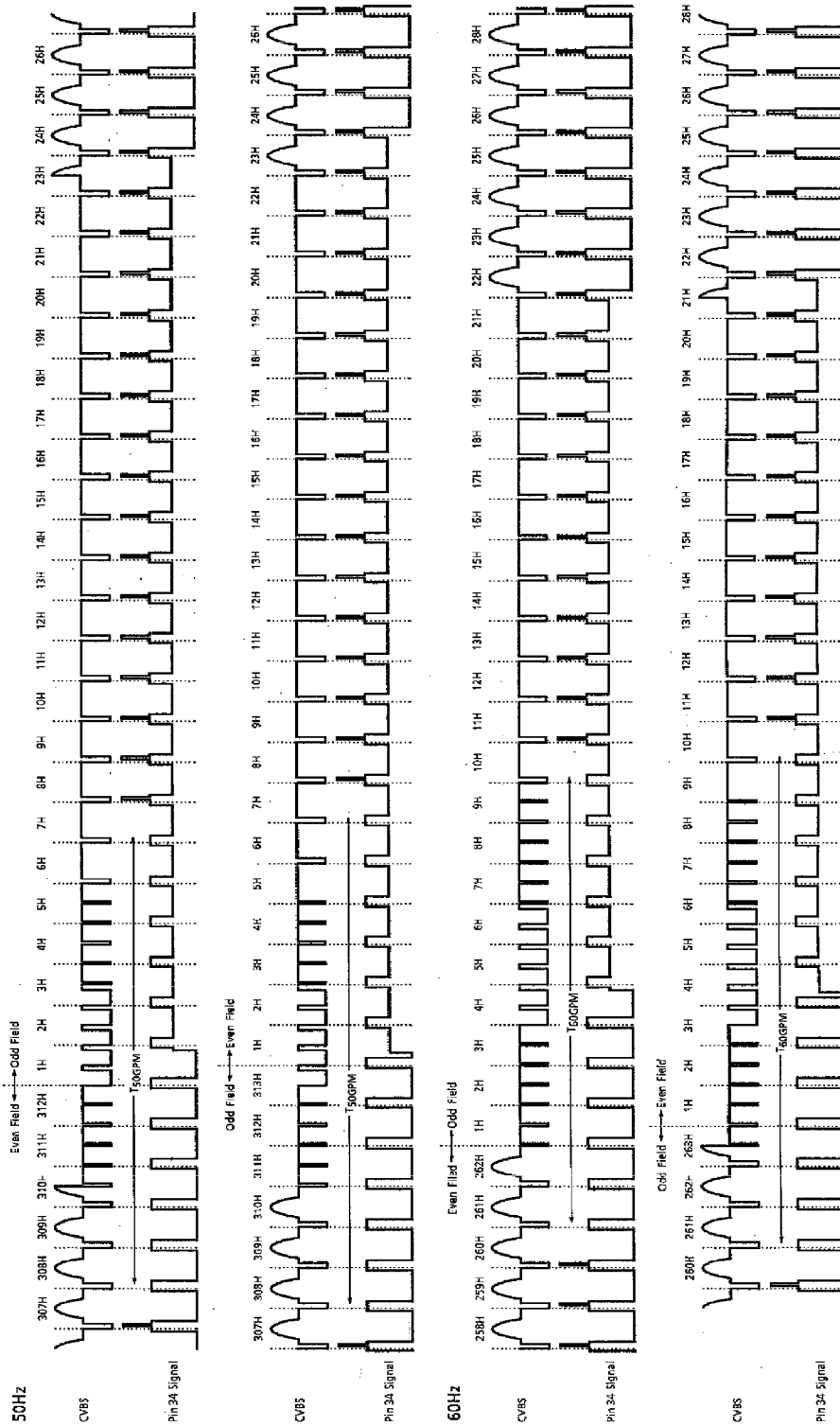

Fig. D21

TB1238N - 70

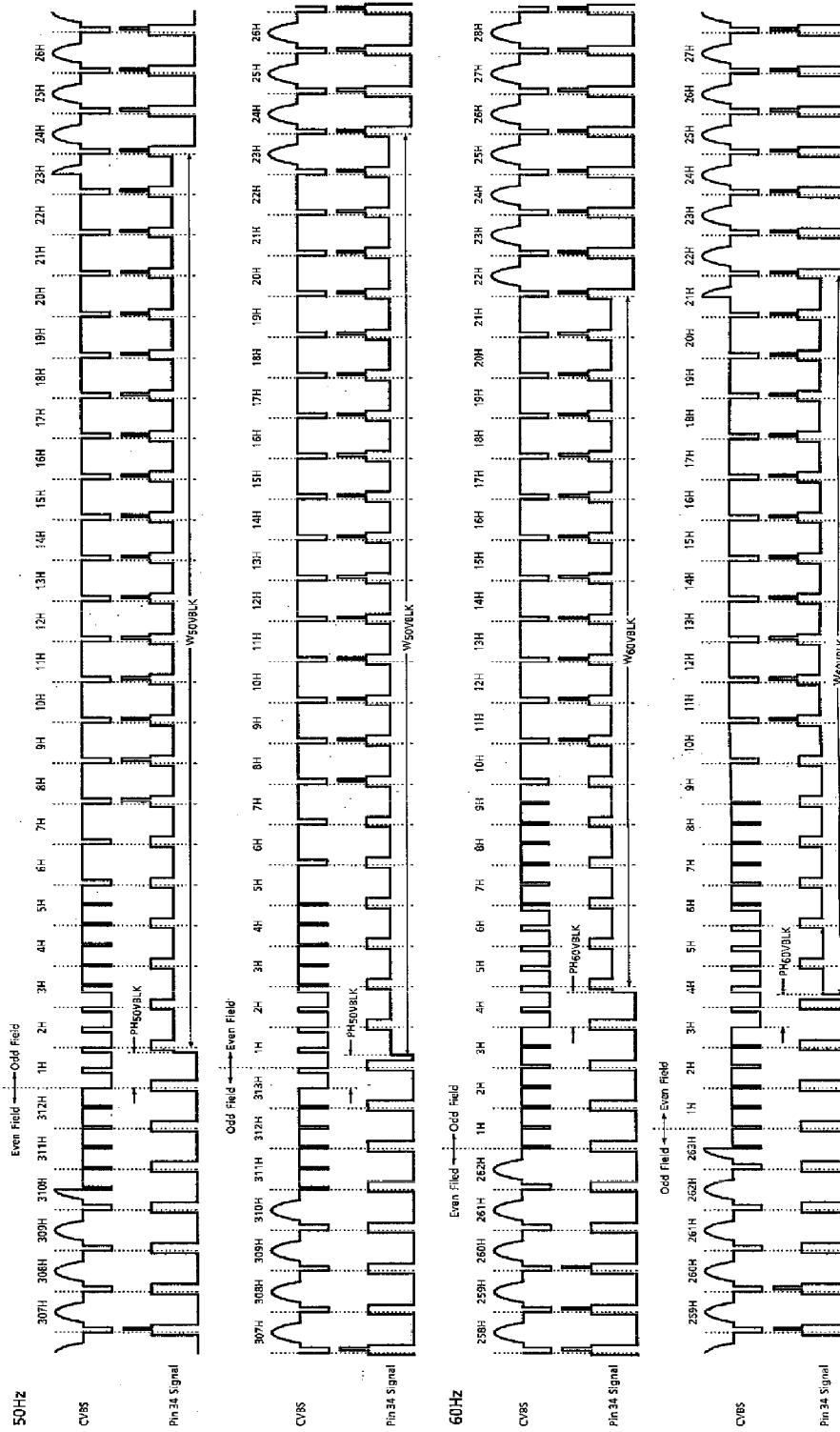
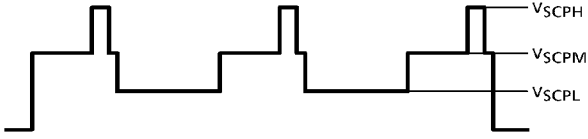
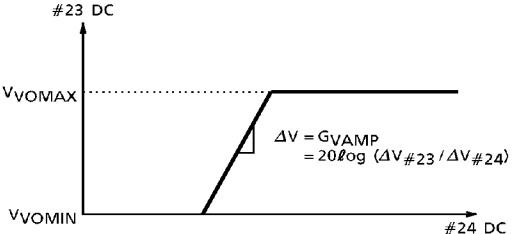
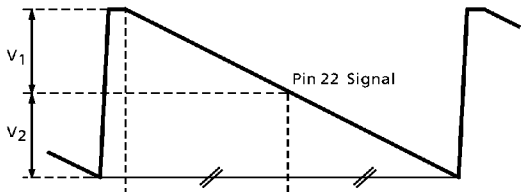

Fig. D25

TB1238N - 71

NOTE	ITEM / SYMBOL	BUS CONDITION	MEASUREMENT METHOD
D27	Sand Castle Pulse Level /VSCPH /VSCPM /VSCPL	All : Preset	Measure "VSCPH" / "VSCPM" / "VSCPL" at Pin 34. 
D28	Vertical Ramp Amplitude /VVRAMP	All : Preset	Measure the V Ramp amplitude at Pin 22, that is "VVRAMP".
D29	Vertical AMP Gain /GVAMP	All : Preset	(1) Let Pin 24 be open. (2) Changing the Pin 23 DC voltage, measure "VVOMAX" / "VVOMIN" / "GVAMP" according to a following figure. 
	Vertical AMP Max. Output Level /VVOMAX		
	Vertical AMP Min. Output Level /VVOMIN		
D30	Vertical AMP Max. Output Current /IVOMAX	All : Preset	(1) Supply 7V to Pin 23. (2) Measure the Current from Pin 24 to GND, that is "IVOMAX".
D31	Vertical NFB Amplitude /VNFB	V Size : 0 / 32 / 63 Others : Preset	(1) Measure the amplitude of NFB V Ramp at Pin 23, that is "VNFB". (2) Measure the amplitude of NFB V Ramp at Pin 23 for V-Size 0 / 63, that is VNFBMIN / VNFBMAX. (3) Calculate ; "ΔVVRAMPH" = (VNFBMAX - VNFB) / VNFB * 100 "ΔVVRAMPL" = (VNFBMIN - VNFB) / VNFB * 100
	Vertical Amplitude Variable Range /ΔVVRAMPH /ΔVVRAMPL		



NOTE	ITEM / SYMBOL	BUS CONDITION	MEASUREMENT METHOD
D32	Vertical Linearity Variable Range / $\Delta V_{LIN1+}$ / $\Delta V_{LIN1-}$ / $\Delta V_{LIN2+}$ / $\Delta V_{LIN2-}$	V Linearity : 0 / 8 / 15 Others : Preset	(1) For V linearity 8, Measure $V_1$ (From center to max.) and $V_2$ (From center to min.) at Pin 22 according to a following figure.  (2) For V linearity 15 / 0, measure $V_{LIN1+}$ / $V_{LIN1-}$ and $V_{LIN2+}$ / $V_{LIN2-}$ . (3) Calculate ; $" \Delta V_{LIN1+} " = (V_{LIN1+} - V_1) / V_1 * 100$ $" \Delta V_{LIN1-} " = (V_{LIN1-} - V_1) / V_1 * 100$ $" \Delta V_{LIN2+} " = (V_{LIN2+} - V_2) / V_2 * 100$ $" \Delta V_{LIN2-} " = (V_{LIN2-} - V_2) / V_2 * 100$
D33	Vertical S Correction Variable Range / $\Delta V_{S1+}$ / $\Delta V_{S1-}$ / $\Delta V_{S2+}$ / $\Delta V_{S2-}$	V S Corr. : 0 / 8 / 15 Others : Preset	(1) For V S Correction : 8, measure $V_1$ and $V_2$ at Pin 22 according to a figure of NOTE : D32. (2) For V S Correction : 15 / 0, measure $V_{S1+}$ / $V_{S1-}$ and $V_{S2+}$ / $V_{S2-}$ . (3) Calculate ; $" \Delta V_{S1+} " = (V_{S1+} - V_1) / V_1 * 100$ $" \Delta V_{S1-} " = (V_{S1-} - V_1) / V_1 * 100$ $" \Delta V_{S2+} " = (V_{S2+} - V_2) / V_2 * 100$ $" \Delta V_{S2-} " = (V_{S2-} - V_2) / V_2 * 100$
D34	V-AGC Current / $I_{VAGCH}$ / $I_{VAGCL}$	V-AGC : 0 / 1 Others : Preset	(1) Connect Pin 25 to GND via a 200 resistor. (2) For V-AGC : 0 / 1, measure $V_{VAGCL}$ / $V_{VAGCH}$ at Pin 25 according to a following figure. (3) Calculate ; $" I_{VAGCL} " = V_{VAGCL} / 200$ $" I_{VAGCH} " = V_{VAGCH} / 200$
D35	Vertical Guard Voltage / $V_{VG}$	All : Preset	Decreasing the Pin 23 voltage from 5V, measure the voltage at which Pin 20 output drops to blanking level, that is " $V_{VG}$ ".

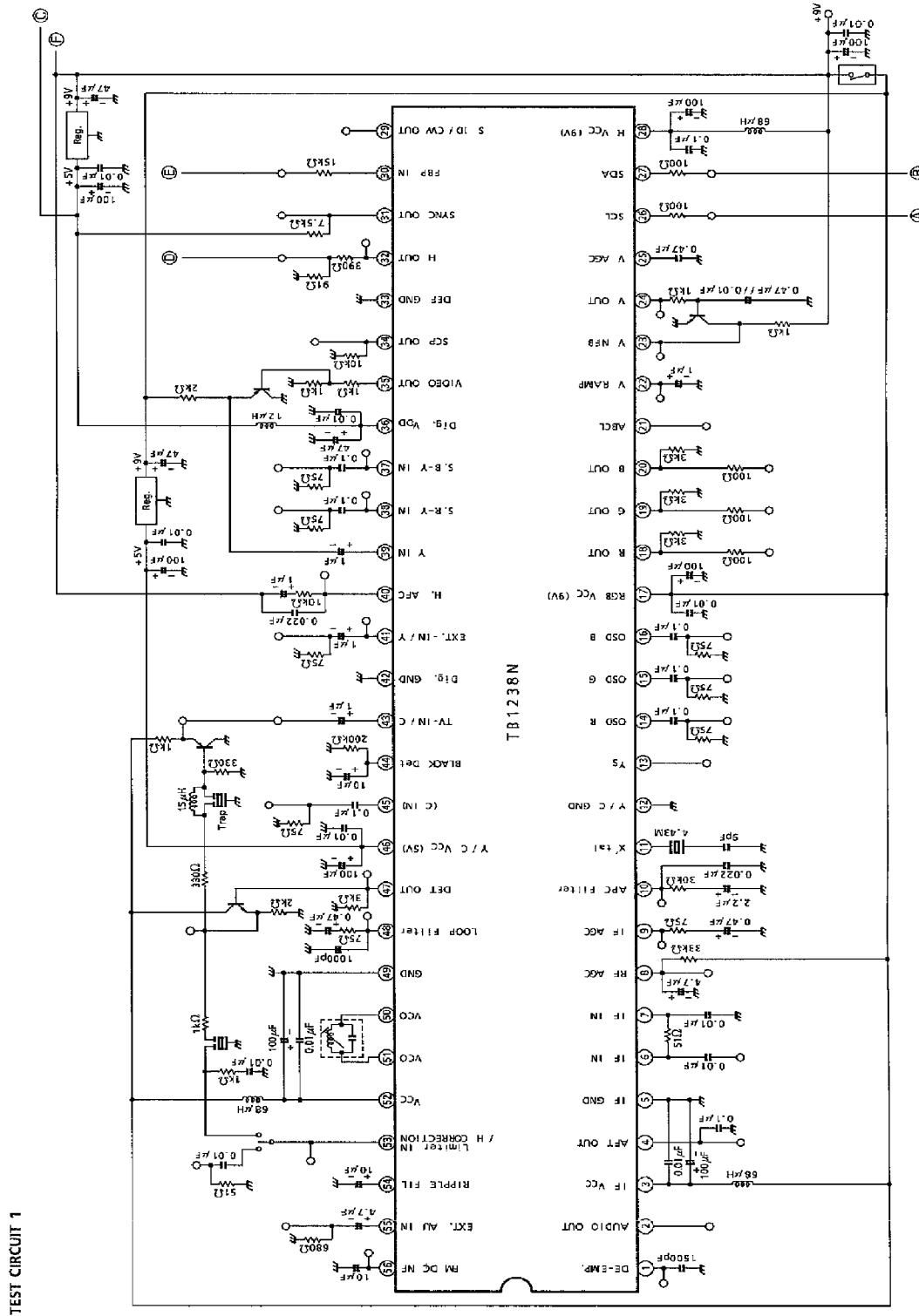

TEST CIRCUIT 2

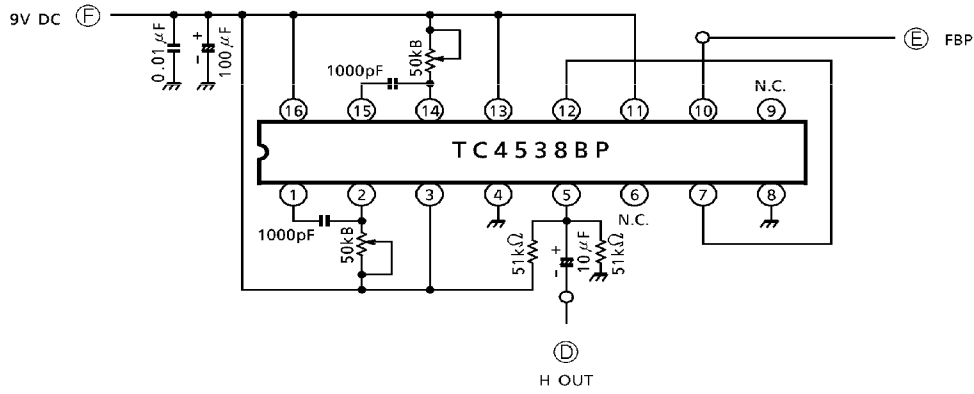

Mono Multi Vibrator

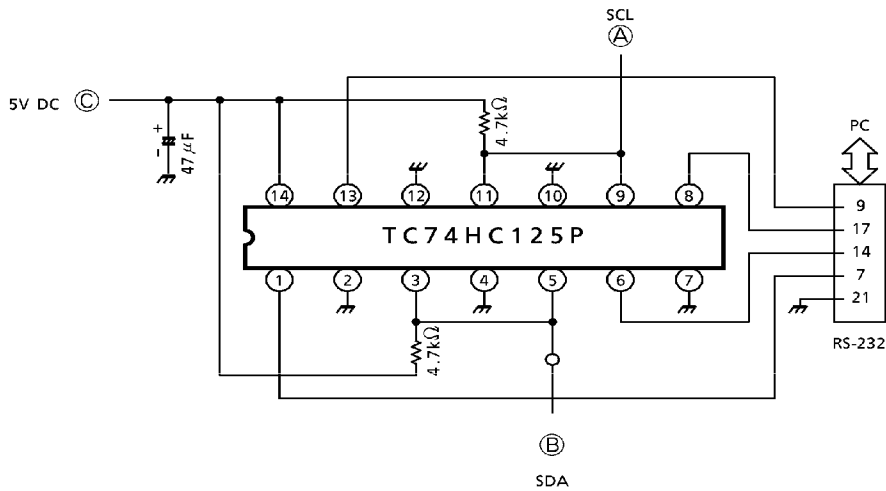

I<sup>2</sup>C BUS Interface

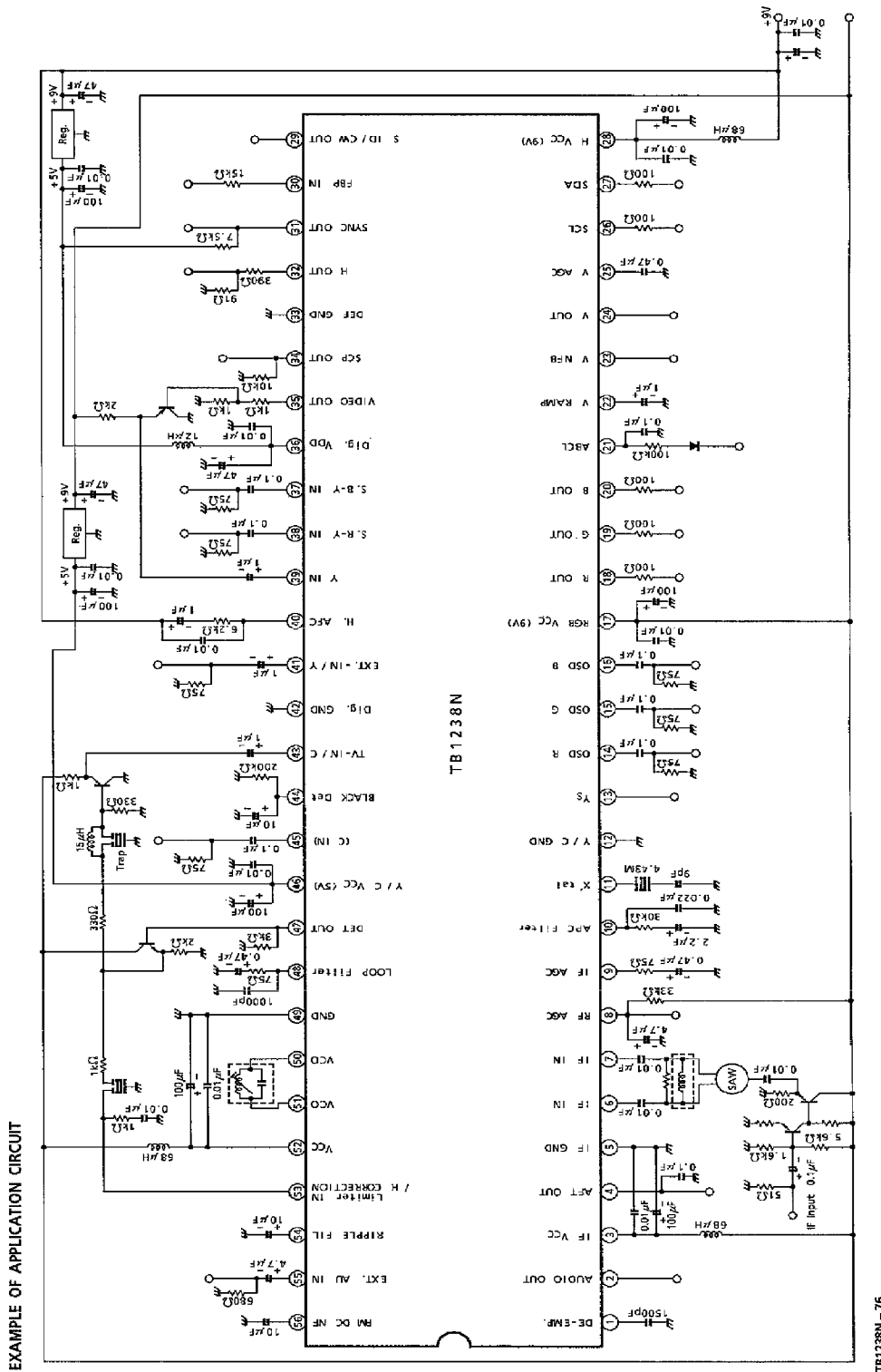

EXAMPLE OF APPLICATION CIRCUIT

TB1238N

TB1238N - 76

OUTLINE DRAWING  
SDIP56-P-600-1.78

Unit : mm

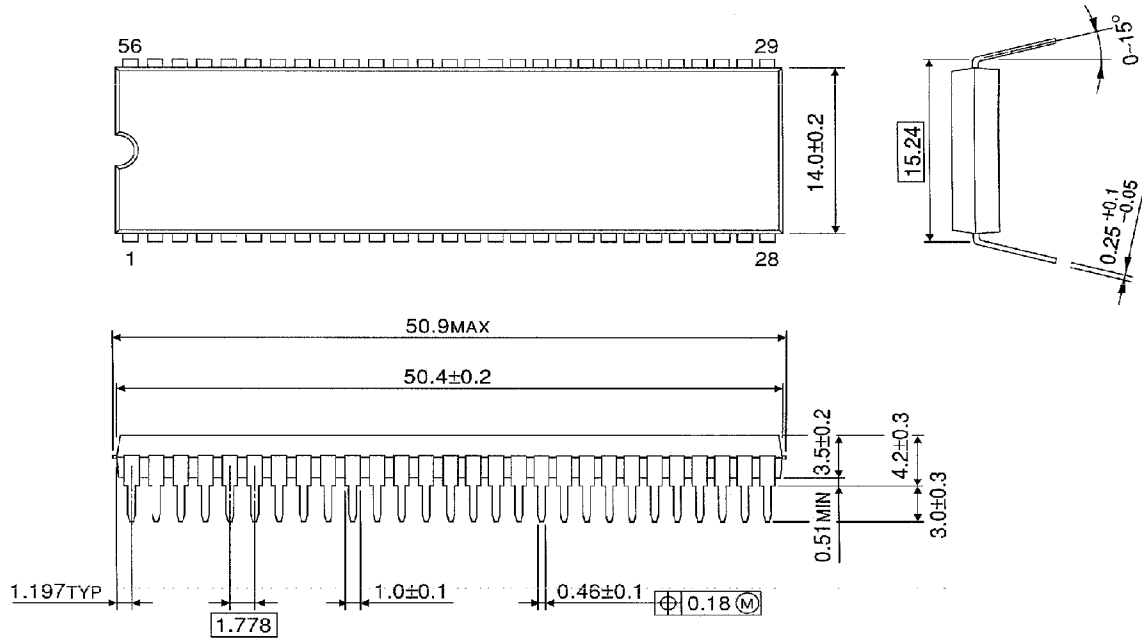

Weight : 5.55g (Typ.)