HM5164800A Series

HM5165800A Series

8388608-word × 8-bit Dynamic Random Access Memory

HITACHI

ADE-203-595(Z)

Preliminary

Rev. 0.1

Jan. 22, 1997

Description

The Hitachi HM5164800A Series, HM5165800A Series are CMOS dynamic RAMs organized as 8,388,608-word × 8-bit. They employ the most advanced CMOS technology for high performance and low power. The HM5164800A Series, HM5165800A Series offer Fast Page Mode as a high speed access mode. They have the package variations of standard 400-mil 32-pin plastic SOJ and standard 400-mil 32-pin plastic TSOPII.

Features

- Single 3.3 V (± 0.3 V)
- High speed
 - Access time: 50 ns/60 ns/70 ns (max)
- Low power dissipation
 - Active mode : TBD/396 mW/342 mW (max) (HM5164800A Series)
: TBD/576 mW/504 mW (max) (HM5165800A Series)
 - Standby mode : 7.2 mW (max)
: TBD (L-version)
- Fast page mode capability
- Long refresh period
 - 8192 $\overline{\text{RAS}}$ only refresh cycles : 64 ms (HM5164800A Series)
4096 CBR/Hidden refresh cycles : 64 ms
: 128 ms (L-version)
 - 4096 $\overline{\text{RAS}}$ only refresh cycles : 64 ms (HM5165800A Series)
4096 CBR/Hidden refresh cycles : 64 ms
: 128 ms (L-version)

Preliminary: This document contains information on a new product. Specifications and information contained herein are subject to change without notice.

HM5164800A Series, HM5165800A Series

- 4 variations of refresh
 - $\overline{\text{RAS}}$ -only refresh
 - $\overline{\text{CAS}}$ -before- $\overline{\text{RAS}}$ refresh
 - Hidden refresh
 - Self refresh (L-version)
- Battery backup operation (L-version)

Ordering Information

Type No.	Access time	Package
HM5164800AJ-5	50 ns	400-mil 32-pin plastic SOJ (CP-32DC)
HM5164800AJ-6	60 ns	
HM5164800AJ-7	70 ns	
HM5164800ALJ-5	50 ns	
HM5164800ALJ-6	60 ns	
HM5164800ALJ-7	70 ns	
HM5165800AJ-5	50 ns	
HM5165800AJ-6	60 ns	
HM5165800AJ-7	70 ns	
HM5165800ALJ-5	50 ns	
HM5165800ALJ-6	60 ns	
HM5165800ALJ-7	70 ns	
HM5164800ATT-5	50 ns	400-mil 32-pin plastic TSOP II (TTP-32DC)
HM5164800ATT-6	60 ns	
HM5164800ATT-7	70 ns	
HM5164800ALTT-5	50 ns	
HM5164800ALTT-6	60 ns	
HM5164800ALTT-7	70 ns	
HM5165800ATT-5	50 ns	
HM5165800ATT-6	60 ns	
HM5165800ATT-7	70 ns	
HM5165800ALTT-5	50 ns	
HM5165800ALTT-6	60 ns	
HM5165800ALTT-7	70 ns	

Pin Arrangement

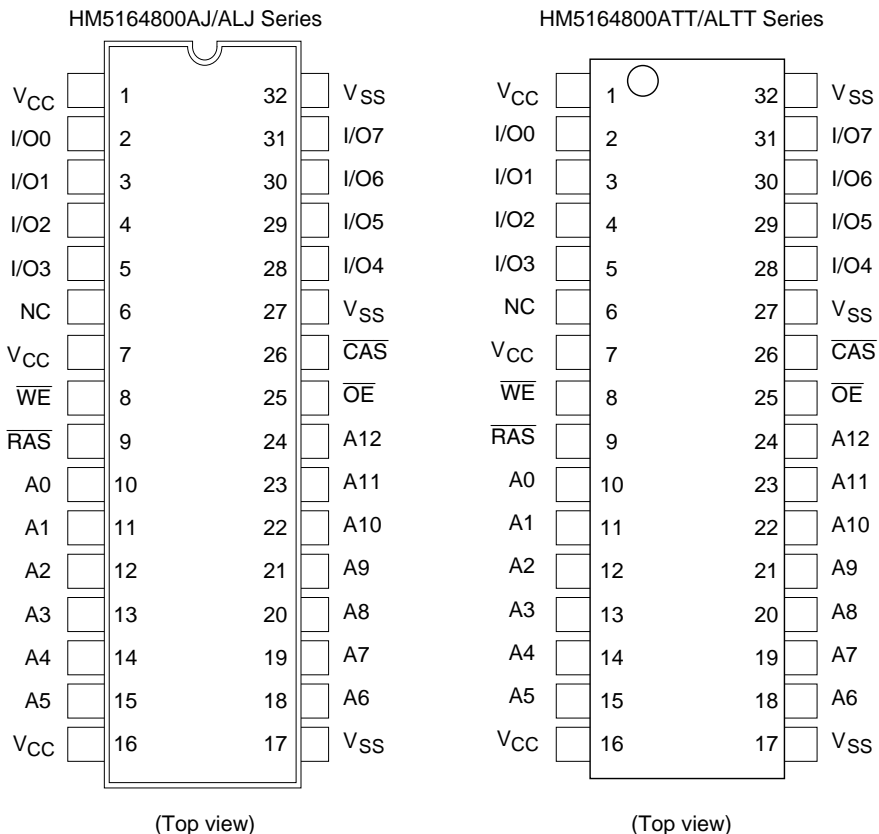

Pin Description

Pin name	Function
A0 to A12	Address input — Row/Refresh address A0 to A12 — Column address A0 to A9
I/O0 to I/O7	Data input/Data output
$\overline{\text{RAS}}$	Row address strobe
$\overline{\text{CAS}}$	Column address strobe
$\overline{\text{WE}}$	Read/Write enable
$\overline{\text{OE}}$	Output enable
V_{CC}	Power supply
V_{SS}	Ground
NC	No connection

HM5164800A Series, HM5165800A Series

Pin Arrangement

HM5165800AJ/ALJ Series

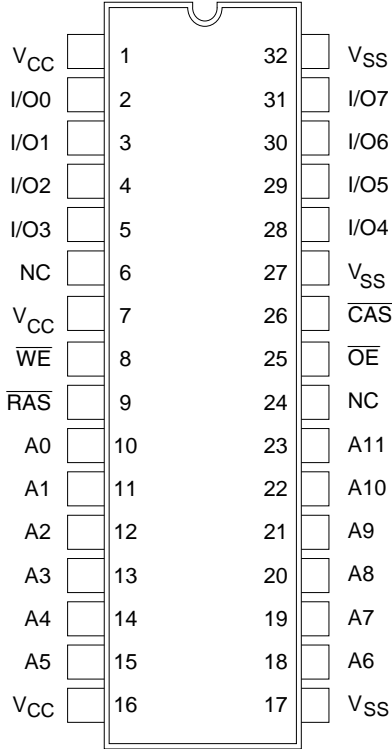

(Top view)

HM5165800ATT/ALTT Series

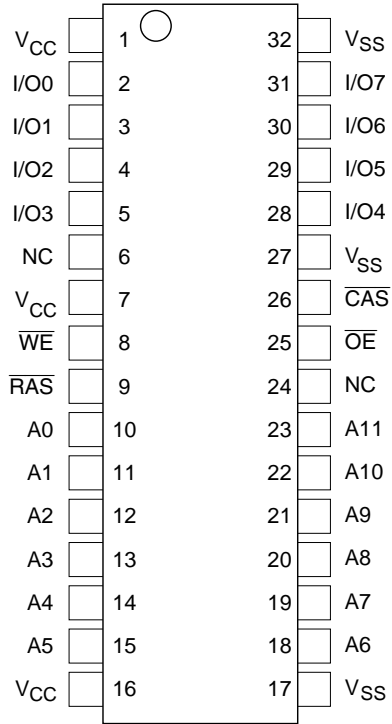

(Top view)

Pin Description

Pin name	Function
A0 to A11	Address input — Row/Refresh address A0 to A11 — Column address A0 to A10
I/O0 to I/O7	Data input/Data output
RAS	Row address strobe
CAS	Column address strobe
WE	Read/Write enable
OE	Output enable
V _{CC}	Power supply
V _{SS}	Ground
NC	No connection

Block Diagram (HM5164800A Series)

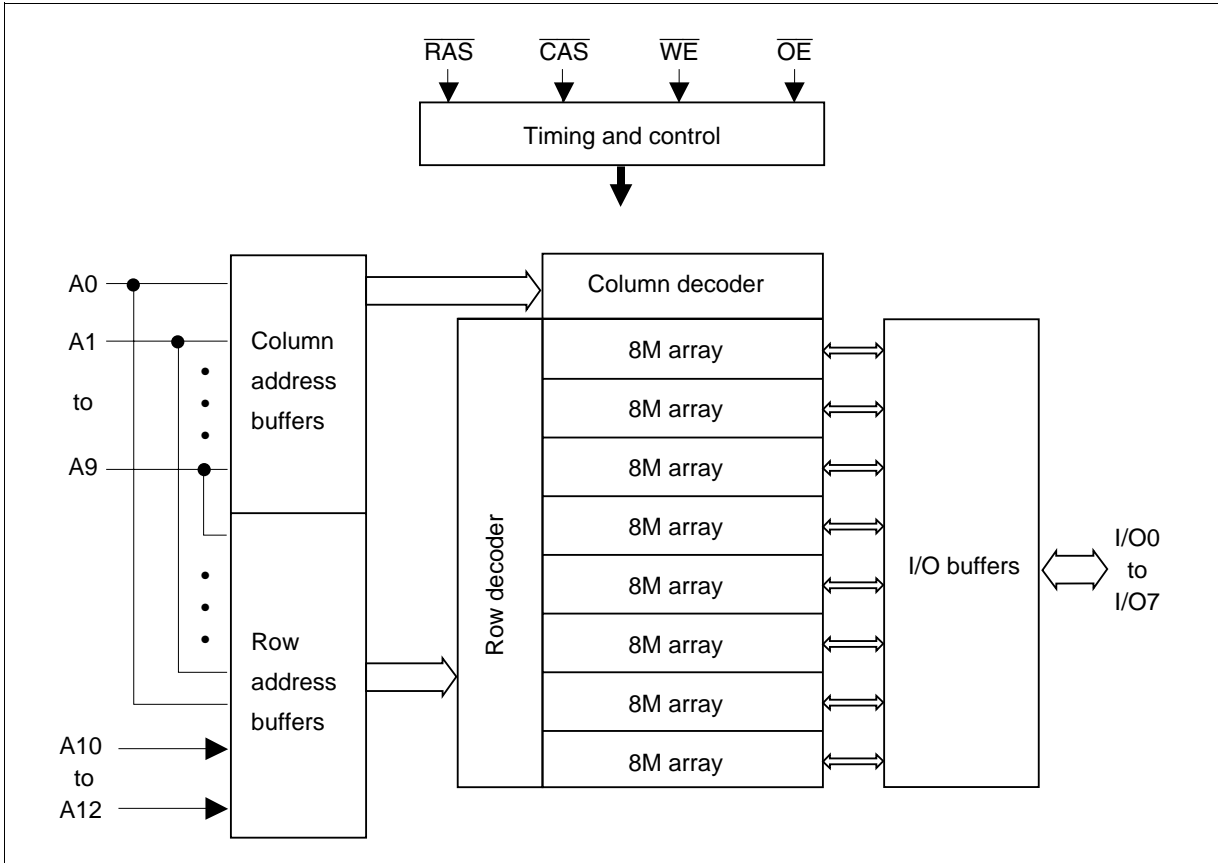

HM5164800A Series, HM5165800A Series

Block Diagram (HM5165800A Series)

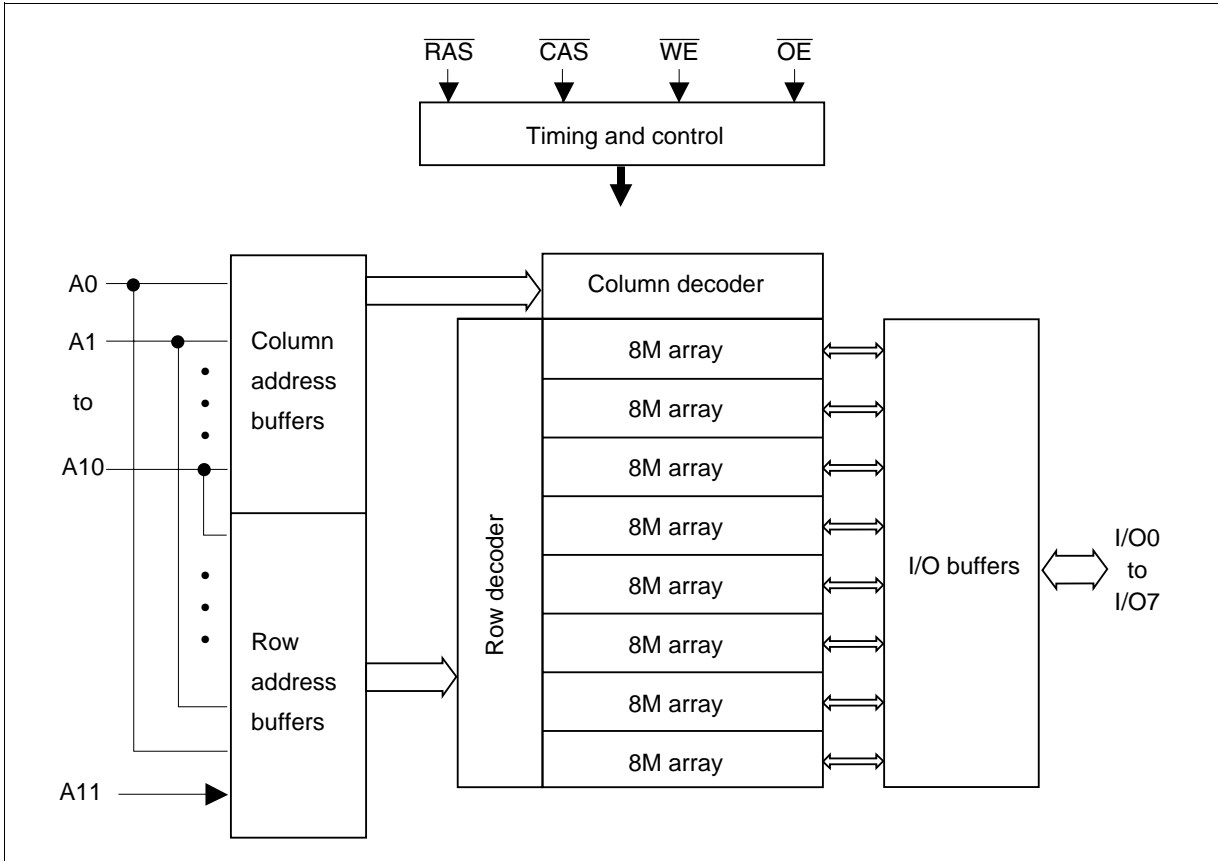

Absolute Maximum Ratings

Parameter	Symbol	Value	Unit
Voltage on any pin relative to V_{SS}	V_T	-0.5 to $V_{CC} + 0.5$ (≤ 4.6 V (max))	V
Supply voltage relative to V_{SS}	V_{CC}	-0.5 to $+4.6$	V
Short circuit output current	I_{out}	50	mA
Power dissipation	P_T	1.0	W
Operating temperature	T_{opr}	0 to $+70$	$^{\circ}C$
Storage temperature	T_{stg}	-55 to $+125$	$^{\circ}C$

Recommended DC Operating Conditions ($T_a = 0$ to $+70^{\circ}C$)

Parameter	Symbol	Min	Typ	Max	Unit	Notes
Supply voltage	V_{CC}	3.0	3.3	3.6	V	1, 2
Input high voltage	V_{IH}	2.0	—	$V_{CC} + 0.3$	V	1
Input low voltage	V_{IL}	-0.3	—	0.8	V	1

- Notes: 1. All voltage referred to V_{SS}
 2. The supply voltage with all V_{CC} pins must be on the same level. The supply voltage with all V_{SS} pins must be on the same level.

HM5164800A Series, HM5165800A Series

DC Characteristics

($T_a = 0$ to $+70^\circ\text{C}$, $V_{CC} = 3.3 \text{ V} \pm 0.3 \text{ V}$, $V_{SS} = 0 \text{ V}$) (HM5164800A Series)

Parameter	Symbol	HM5164800A						Unit	Test conditions
		-5		-6		-7			
		Min	Max	Min	Max	Min	Max		
Operating current* ¹ , * ²	I_{CC1}	—	TBD	—	110	—	95	mA	$t_{RC} = \text{min}$
Standby current	I_{CC2}	—	TBD	—	2	—	2	mA	TTL interface $\overline{\text{RAS}}, \overline{\text{CAS}} = V_{IH}$ Dout = High-Z
		—	TBD	—	1	—	1	mA	CMOS interface $\overline{\text{RAS}}, \overline{\text{CAS}} \geq V_{CC} - 0.2 \text{ V}$ Dout = High-Z
Standby current (L-version)	I_{CC2}	—	TBD	—	TBD	—	TBD	μA	CMOS interface $\overline{\text{RAS}}, \overline{\text{CAS}} \geq V_{CC} - 0.2 \text{ V}$ Dout = High-Z
$\overline{\text{RAS}}$ -only refresh current* ²	I_{CC3}	—	TBD	—	110	—	95	mA	$t_{RC} = \text{min}$
Standby current* ¹	I_{CC5}	—	TBD	—	5	—	5	mA	$\overline{\text{RAS}} = V_{IH}$, $\overline{\text{CAS}} = V_{IL}$ Dout = enable
$\overline{\text{CAS}}$ -before- $\overline{\text{RAS}}$ refresh current	I_{CC6}	—	TBD	—	140	—	120	mA	$t_{RC} = \text{min}$
Fast page mode current* ¹ , * ³	I_{CC7}	—	TBD	—	85	—	75	mA	$t_{PC} = \text{min}$
Battery backup current* ⁴ (Standby with CBR refresh) (L-version)	I_{CC10}	—	TBD	—	TBD	—	TBD	μA	CMOS interface Dout = High-Z, CBR refresh: $t_{RC} = 31.3 \mu\text{s}$ $t_{RAS} \leq 0.3 \mu\text{s}$
Self refresh mode current (L-version)	I_{CC11}	—	TBD	—	TBD	—	TBD	μA	CMOS interface $\overline{\text{RAS}}, \overline{\text{CAS}} \leq 0.2 \text{ V}$ Dout = High-Z
Input leakage current	I_{LI}	TBD	TBD	-10	10	-10	10	μA	$0 \text{ V} \leq V_{in} \leq V_{CC} + 0.3 \text{ V}$
Output leakage current	I_{LO}	TBD	TBD	-10	10	-10	10	μA	$0 \text{ V} \leq V_{in} \leq V_{CC}$ Dout = disable
Output high voltage	V_{OH}	TBD	TBD	2.4	V_{CC}	2.4	V_{CC}	V	High Iout = -2 mA
Output low voltage	V_{OL}	TBD	TBD	0	0.4	0	0.4	V	Low Iout = 2 mA

Notes: 1. I_{CC} depends on output load condition when the device is selected. I_{CC} max is specified at the output open condition.

2. Address can be changed once or less while $\overline{\text{RAS}} = V_{IL}$.

3. Address can be changed once or less within one page mode cycle t_{PC} .

4. $V_{IH} \geq V_{CC} - 0.2 \text{ V}$, $0 \text{ V} \leq V_{IL} \leq 0.2 \text{ V}$.

DC Characteristics

($T_a = 0$ to $+70^\circ\text{C}$, $V_{CC} = 3.3\text{ V} \pm 0.3\text{ V}$, $V_{SS} = 0\text{ V}$) (HM5165800A Series)

Parameter	Symbol	HM5165800A						Unit	Test conditions
		-5		-6		-7			
		Min	Max	Min	Max	Min	Max		
Operating current* ¹ , * ²	I_{CC1}	—	TBD	—	160	—	140	mA	$t_{RC} = \text{min}$
Standby current	I_{CC2}	—	TBD	—	2	—	2	mA	TTL interface $\overline{\text{RAS}}, \overline{\text{CAS}} = V_{IH}$ Dout = High-Z
		—	TBD	—	1	—	1	mA	CMOS interface $\overline{\text{RAS}}, \overline{\text{CAS}} \geq V_{CC} - 0.2\text{ V}$ Dout = High-Z
Standby current (L-version)	I_{CC2}	—	TBD	—	TBD	—	TBD	μA	CMOS interface $\overline{\text{RAS}}, \overline{\text{CAS}} \geq V_{CC} - 0.2\text{ V}$ Dout = High-Z
$\overline{\text{RAS}}$ -only refresh current* ²	I_{CC3}	—	TBD	—	160	—	140	mA	$t_{RC} = \text{min}$
Standby current* ¹	I_{CC5}	—	TBD	—	5	—	5	mA	$\overline{\text{RAS}} = V_{IH}$, $\overline{\text{CAS}} = V_{IL}$ Dout = enable
$\overline{\text{CAS}}$ -before- $\overline{\text{RAS}}$ refresh current	I_{CC6}	—	TBD	—	140	—	120	mA	$t_{RC} = \text{min}$
Fast page mode current* ¹ , * ³	I_{CC7}	—	TBD	—	100	—	90	mA	$t_{PC} = \text{min}$
Battery backup current* ⁴ (Standby with CBR refresh) (L-version)	I_{CC10}	—	TBD	—	TBD	—	TBD	μA	CMOS interface Dout = High-Z, CBR refresh: $t_{RC} = 31.3\ \mu\text{s}$ $t_{RAS} \leq 0.3\ \mu\text{s}$
Self refresh mode current (L-version)	I_{CC11}	—	TBD	—	TBD	—	TBD	μA	CMOS interface $\overline{\text{RAS}}, \overline{\text{CAS}} \leq 0.2\text{ V}$ Dout = High-Z
Input leakage current	I_{LI}	TBD	TBD	-10	10	-10	10	μA	$0\text{ V} \leq V_{in} \leq V_{CC} + 0.3\text{ V}$
Output leakage current	I_{LO}	TBD	TBD	-10	10	-10	10	μA	$0\text{ V} \leq V_{in} \leq V_{CC}$ Dout = disable
Output high voltage	V_{OH}	TBD	TBD	2.4	V_{CC}	2.4	V_{CC}	V	High Iout = -2 mA
Output low voltage	V_{OL}	TBD	TBD	0	0.4	0	0.4	V	Low Iout = 2 mA

Notes: 1. I_{CC} depends on output load condition when the device is selected. I_{CC} max is specified at the output open condition.

2. Address can be changed once or less while $\overline{\text{RAS}} = V_{IL}$.

3. Address can be changed once or less within one page mode cycle t_{PC} .

4. $V_{IH} \geq V_{CC} - 0.2\text{ V}$, $0\text{ V} \leq V_{IL} \leq 0.2\text{ V}$.

HM5164800A Series, HM5165800A Series

Capacitance ($T_a = 25^\circ\text{C}$, $V_{CC} = 3.3\text{ V} \pm 0.3\text{ V}$)

Parameter	Symbol	Typ	Max	Unit	Notes
Input capacitance (Address)	C_{I1}	—	5	pF	1
Input capacitance (Clocks)	C_{I2}	—	7	pF	1
Output capacitance (Data-in, Data-out)	$C_{I/O}$	—	7	pF	1, 2

Notes : 1. Capacitance measured with Boonton Meter or effective capacitance measuring method.

2. $\overline{\text{RAS}}$, $\overline{\text{CAS}} = V_{IH}$ to disable Dout.

AC Characteristics (Ta = 0 to +70°C, V_{CC} = 3.3 V ± 0.3 V, V_{SS} = 0 V) *1, *2, *17

Test Conditions

- Input rise and fall time: 5 ns
- Input timing reference levels: 0.8 V, 2.0 V
- Output timing reference levels: 0.8 V, 2.0 V
- Output load: 1 TTL gate + C_L (100 pF) (Including scope and jig)

Read, Write, Read-Modify-Write and Refresh Cycles (Common parameters)

		HM5164800A/HM5165800A							
		-5		-6		-7			
Parameter	Symbol	Min	Max	Min	Max	Min	Max	Unit	Notes
Random read or write cycle time	t _{RC}	TBD	—	110	—	130	—	ns	
$\overline{\text{RAS}}$ precharge time	t _{RP}	TBD	—	40	—	50	—	ns	
$\overline{\text{CAS}}$ precharge time	t _{CP}	TBD	—	10	—	10	—	ns	
$\overline{\text{RAS}}$ pulse width	t _{RAS}	TBD	TBD	60	10000	70	10000	ns	
$\overline{\text{CAS}}$ pulse width	t _{CAS}	TBD	TBD	15	10000	18	10000	ns	
Row address setup time	t _{ASR}	TBD	—	0	—	0	—	ns	
Row address hold time	t _{RAH}	TBD	—	10	—	10	—	ns	
Column address setup time	t _{ASC}	TBD	—	0	—	0	—	ns	
Column address hold time	t _{CAH}	TBD	—	10	—	15	—	ns	
$\overline{\text{RAS}}$ to $\overline{\text{CAS}}$ delay time	t _{RCD}	TBD	TBD	20	45	20	52	ns	3
$\overline{\text{RAS}}$ to column address delay time	t _{RAD}	TBD	TBD	15	30	15	35	ns	4
$\overline{\text{RAS}}$ hold time	t _{RSH}	TBD	—	15	—	18	—	ns	
$\overline{\text{CAS}}$ hold time	t _{CSH}	TBD	—	60	—	70	—	ns	
$\overline{\text{CAS}}$ to $\overline{\text{RAS}}$ precharge time	t _{CRP}	TBD	—	5	—	5	—	ns	
$\overline{\text{OE}}$ to Din delay time	t _{OED}	TBD	—	15	—	18	—	ns	5
$\overline{\text{OE}}$ delay time from Din	t _{DZO}	TBD	—	0	—	0	—	ns	6
$\overline{\text{CAS}}$ delay time from Din	t _{DZC}	TBD	—	0	—	0	—	ns	6
Transition time (rise and fall)	t _T	TBD	TBD	3	50	3	50	ns	7

HM5164800A Series, HM5165800A Series

Read Cycle

Parameter	Symbol	HM5164800A/HM5165800A						Unit	Notes
		-5		-6		-7			
		Min	Max	Min	Max	Min	Max		
Access time from $\overline{\text{RAS}}$	t_{RAC}	—	TBD	—	60	—	70	ns	8, 9
Access time from $\overline{\text{CAS}}$	t_{CAC}	—	TBD	—	15	—	18	ns	9, 10, 16
Access time from address	t_{AA}	—	TBD	—	30	—	35	ns	9, 11, 16
Access time from $\overline{\text{OE}}$	t_{OEA}	—	TBD	—	15	—	18	ns	9, 19
Read command setup time	t_{RCS}	TBD	—	0	—	0	—	ns	
Read command hold time to $\overline{\text{CAS}}$	t_{RCH}	TBD	—	0	—	0	—	ns	12
Read command hold time to $\overline{\text{RAS}}$	t_{RRH}	TBD	—	5	—	5	—	ns	12
Column address to $\overline{\text{RAS}}$ lead time	t_{RAL}	TBD	—	30	—	35	—	ns	
Column address to $\overline{\text{CAS}}$ lead time	t_{CAL}	TBD	—	30	—	35	—	ns	
$\overline{\text{CAS}}$ to output in low-Z	t_{CLZ}	TBD	—	0	—	0	—	ns	
Output data hold time	t_{OH}	TBD	—	3	—	3	—	ns	
Output data hold time from $\overline{\text{OE}}$	t_{OHO}	TBD	—	3	—	3	—	ns	
Output buffer turn-off time	t_{OFF}	—	TBD	—	15	—	15	ns	13
Output buffer turn-off to $\overline{\text{OE}}$	t_{OEZ}	—	TBD	—	15	—	15	ns	13
$\overline{\text{CAS}}$ to Din delay time	t_{CDD}	TBD	—	15	—	18	—	ns	5

Write Cycle

Parameter	Symbol	HM5164800A/HM5165800A						Unit	Notes
		-5		-6		-7			
		Min	Max	Min	Max	Min	Max		
Write command setup time	t_{WCS}	TBD	—	0	—	0	—	ns	14
Write command hold time	t_{WCH}	TBD	—	10	—	15	—	ns	
Write command pulse width	t_{WCP}	TBD	—	10	—	10	—	ns	
Write command to $\overline{\text{RAS}}$ lead time	t_{RWL}	TBD	—	15	—	18	—	ns	
Write command to $\overline{\text{CAS}}$ lead time	t_{CWL}	TBD	—	15	—	18	—	ns	
Data-in setup time	t_{DS}	TBD	—	0	—	0	—	ns	
Data-in hold time	t_{DH}	TBD	—	10	—	15	—	ns	

Read-Modify-Write Cycle

		HM5164800A/HM5165800A							
		-5		-6		-7			
Parameter	Symbol	Min	Max	Min	Max	Min	Max	Unit	Notes
Read-modify-write cycle time	t_{RWC}	TBD	—	155	—	181	—	ns	
\overline{RAS} to \overline{WE} delay time	t_{RWD}	TBD	—	85	—	98	—	ns	14
\overline{CAS} to \overline{WE} delay time	t_{CWD}	TBD	—	40	—	46	—	ns	14
Column address to \overline{WE} delay time	t_{AWD}	TBD	—	55	—	63	—	ns	14
\overline{OE} hold time from \overline{WE}	t_{OEh}	TBD	—	15	—	18	—	ns	

Refresh Cycle

		HM5164800A/HM5165800A							
		-5		-6		-7			
Parameter	Symbol	Min	Max	Min	Max	Min	Max	Unit	Notes
\overline{CAS} setup time (CBR refresh cycle)	t_{CSR}	TBD	—	5	—	5	—	ns	
\overline{CAS} hold time (CBR refresh cycle)	t_{CHR}	TBD	—	10	—	10	—	ns	
\overline{WE} setup time (CBR refresh cycle)	t_{WRP}	TBD	—	0	—	0	—	ns	
\overline{WE} hold time (CBR refresh cycle)	t_{WRH}	TBD	—	10	—	10	—	ns	
\overline{RAS} precharge to \overline{CAS} hold time	t_{RPC}	TBD	—	0	—	0	—	ns	

Fast Page Mode Cycle

		HM5164800A/HM5165800A							
		-5		-6		-7			
Parameter	Symbol	Min	Max	Min	Max	Min	Max	Unit	Notes
Fast page mode cycle time	t_{PC}	TBD	—	40	—	45	—	ns	
Fast page mode \overline{RAS} pulse width	t_{RASP}	—	TBD	—	100000	—	100000	ns	15
Access time from \overline{CAS} precharge	t_{CPA}	—	TBD	—	35	—	40	ns	9, 16
\overline{RAS} hold time from \overline{CAS} precharge	t_{CPRH}	TBD	—	35	—	40	—	ns	

HM5164800A Series, HM5165800A Series

Fast Page Mode Read-Modify-Write Cycle

Parameter	Symbol	HM5164800A/HM5165800A						Unit	Notes
		-5		-6		-7			
		Min	Max	Min	Max	Min	Max		
Fast page mode read-modify-write cycle time	t_{PRWC}	TBD	—	85	—	96	—	ns	
\overline{WE} delay time from \overline{CAS} precharge	t_{CPW}	TBD	—	60	—	68	—	ns	14

Refresh (HM5164800A Series)

Parameter	Symbol	Max	Unit	Note
Refresh period	t_{REF}	64	ms	8192 cycles
Refresh period (L-version)	t_{REF}	128	ms	4096 cycles

Refresh (HM5165800A Series)

Parameter	Symbol	Max	Unit	Note
Refresh period	t_{REF}	64	ms	4096 cycles
Refresh period (L-version)	t_{REF}	128	ms	4096 cycles

Self Refresh Mode (L-version)

Parameter	Symbol	HM5164800AL/HM5165800AL						Unit	Notes
		-5		-6		-7			
		Min	Max	Min	Max	Min	Max		
\overline{RAS} pulse width (Self refresh)	t_{RASS}	TBD	—	100	—	100	—	μ s	20
\overline{RAS} precharge time (Self refresh)	t_{RPS}	TBD	—	110	—	130	—	ns	
\overline{CAS} hold time (Self refresh)	t_{CHS}	TBD	—	-50	—	-50	—	ns	

Notes: 1. AC measurements assume $t_T = 5$ ns.

- An initial pause of 200 μ s is required after power up followed by a minimum of eight initialization cycles (any combination of cycles containing \overline{RAS} -only refresh or \overline{CAS} -before- \overline{RAS} refresh).
- Operation with the t_{RCD} (max) limit insures that t_{RAC} (max) can be met, t_{RCD} (max) is specified as a reference point only; if t_{RCD} is greater than the specified t_{RCD} (max) limit, then access time is controlled exclusively by t_{CAC} .
- Operation with the t_{RAD} (max) limit insures that t_{RAC} (max) can be met, t_{RAD} (max) is specified as a reference point only; if t_{RAD} is greater than the specified t_{RAD} (max) limit, then access time is controlled exclusively by t_{AA} .

5. Either t_{OED} or t_{CDD} must be satisfied.
6. Either t_{DZO} or t_{DZC} must be satisfied.
7. V_{IH} (min) and V_{IL} (max) are reference levels for measuring timing of input signals. Also, transition times are measured between V_{IH} (min) and V_{IL} (max).
8. Assumes that $t_{\text{RCD}} \leq t_{\text{RCD}} (\text{max})$ and $t_{\text{RAD}} \leq t_{\text{RAD}} (\text{max})$. If t_{RCD} or t_{RAD} is greater than the maximum recommended value shown in this table, t_{RAC} exceeds the value shown.
9. Measured with a load circuit equivalent to 1 TTL loads and 100 pF.
10. Assumes that $t_{\text{RCD}} \geq t_{\text{RCD}} (\text{max})$ and $t_{\text{RCD}} + t_{\text{CAC}} (\text{max}) \geq t_{\text{RAD}} + t_{\text{AA}} (\text{max})$.
11. Assumes that $t_{\text{RAD}} \geq t_{\text{RAD}} (\text{max})$ and $t_{\text{RCD}} + t_{\text{CAC}} (\text{max}) \leq t_{\text{RAD}} + t_{\text{AA}} (\text{max})$.
12. Either t_{RCH} or t_{RRH} must be satisfied for a read cycles.
13. $t_{\text{OFF}} (\text{max})$ and $t_{\text{OEZ}} (\text{max})$ define the time at which the outputs achieve the open circuit condition and are not referred to output voltage levels.
14. t_{WCS} , t_{RWD} , t_{CWD} , t_{AWD} and t_{CPW} are not restrictive operating parameters. They are included in the data sheet as electrical characteristics only; if $t_{\text{WCS}} \geq t_{\text{WCS}} (\text{min})$, the cycle is an early write cycle and the data out pin will remain open circuit (high impedance) throughout the entire cycle; if $t_{\text{RWD}} \geq t_{\text{RWD}} (\text{min})$, $t_{\text{CWD}} \geq t_{\text{CWD}} (\text{min})$, and $t_{\text{AWD}} \geq t_{\text{AWD}} (\text{min})$, or $t_{\text{CWD}} \geq t_{\text{CWD}} (\text{min})$, $t_{\text{AWD}} \geq t_{\text{AWD}} (\text{min})$ and $t_{\text{CPW}} \geq t_{\text{CPW}} (\text{min})$, the cycle is a read-modify-write and the data output will contain data read from the selected cell; if neither of the above sets of conditions is satisfied, the condition of the data out (at access time) is indeterminate.
15. t_{RASP} defines $\overline{\text{RAS}}$ pulse width in fast page mode cycles.
16. Access time is determined by the longest among t_{AA} , t_{CAC} and t_{CPA} .
17. All the V_{CC} and V_{SS} pins shall be supplied with the same voltages.
18. In delayed write or read-modify-write cycles, $\overline{\text{OE}}$ must disable output buffer prior to applying data to the device.
19. When output buffers are enabled once, sustain the low impedance state until valid data is obtained. When output buffer is turned on and off within a very short time, generally it causes large $V_{\text{CC}}/V_{\text{SS}}$ line noise, which causes to degrade $V_{\text{IH min}}/V_{\text{IL max}}$ level.
20. Please do not use t_{RASS} timing, $10 \mu\text{s} \leq t_{\text{RASS}} \leq 100 \mu\text{s}$. During this period, the device is in transition state from normal operation mode to self refresh mode. If $t_{\text{RASS}} \geq 100 \mu\text{s}$, then $\overline{\text{RAS}}$ precharge time should use t_{RPS} instead of t_{RP} .
21. CBR burst refresh or 4096 cycles of distributed CBR refresh with $15.6 \mu\text{s}$ interval should be executed within 64 ms immediately after exiting from and before entering into the self refresh mode.
22. Repetitive self refresh mode without refreshing all memory is not allowed. Once you exit from self refresh mode, all memory cells need to be refreshed before re-entering the self refresh mode again.
23. XXX: H or L (H: $V_{\text{IH}} (\text{min}) \leq V_{\text{IN}} \leq V_{\text{IH}} (\text{max})$, L: $V_{\text{IL}} (\text{min}) \leq V_{\text{IN}} \leq V_{\text{IL}} (\text{max})$)
 //////////////: Invalid Dout
 When the address, clock and input pins are not described on timing waveforms, their pins must be applied V_{IH} or V_{IL} .

Timing Waveforms*23

Read Cycle

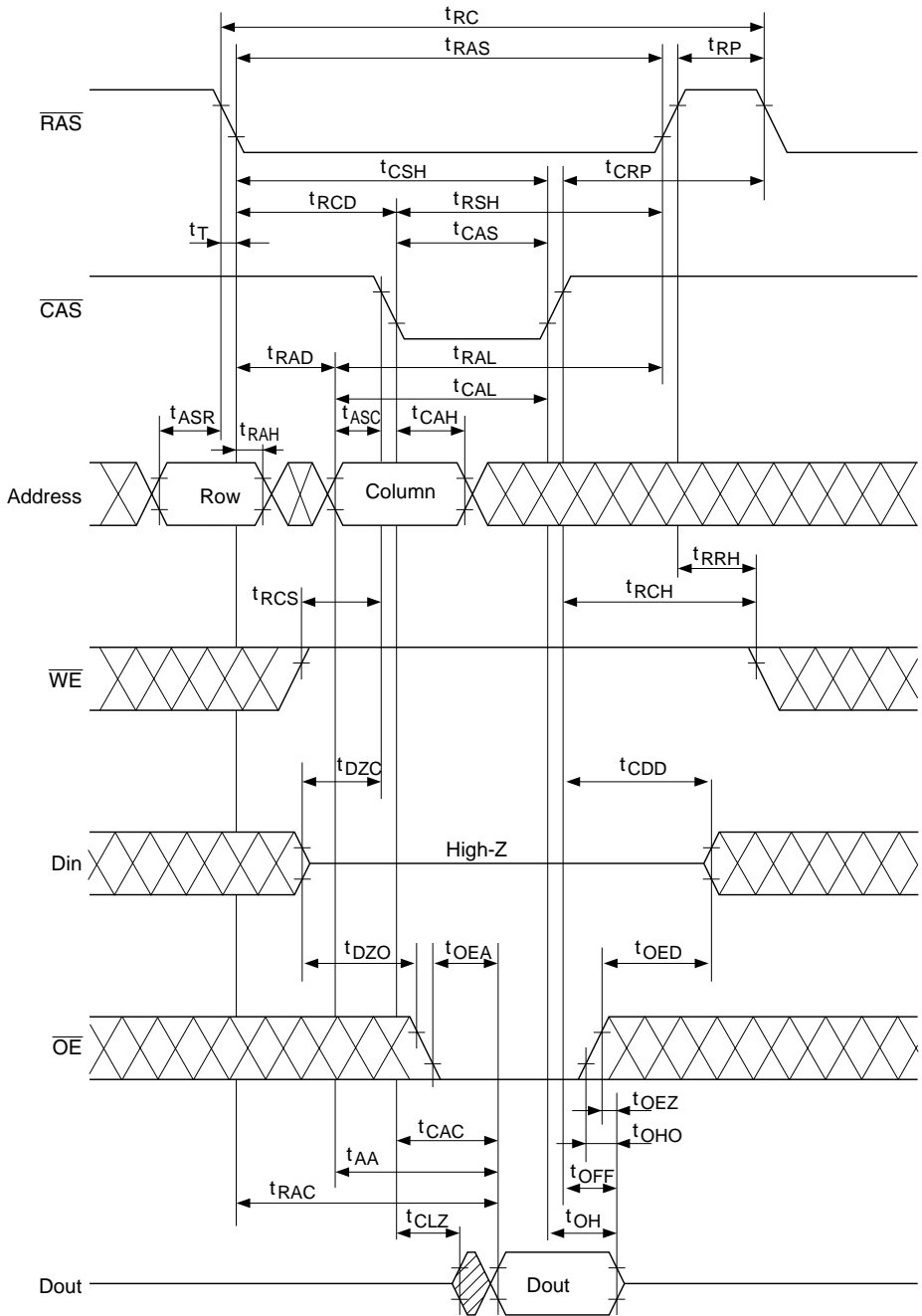

Early Write Cycle

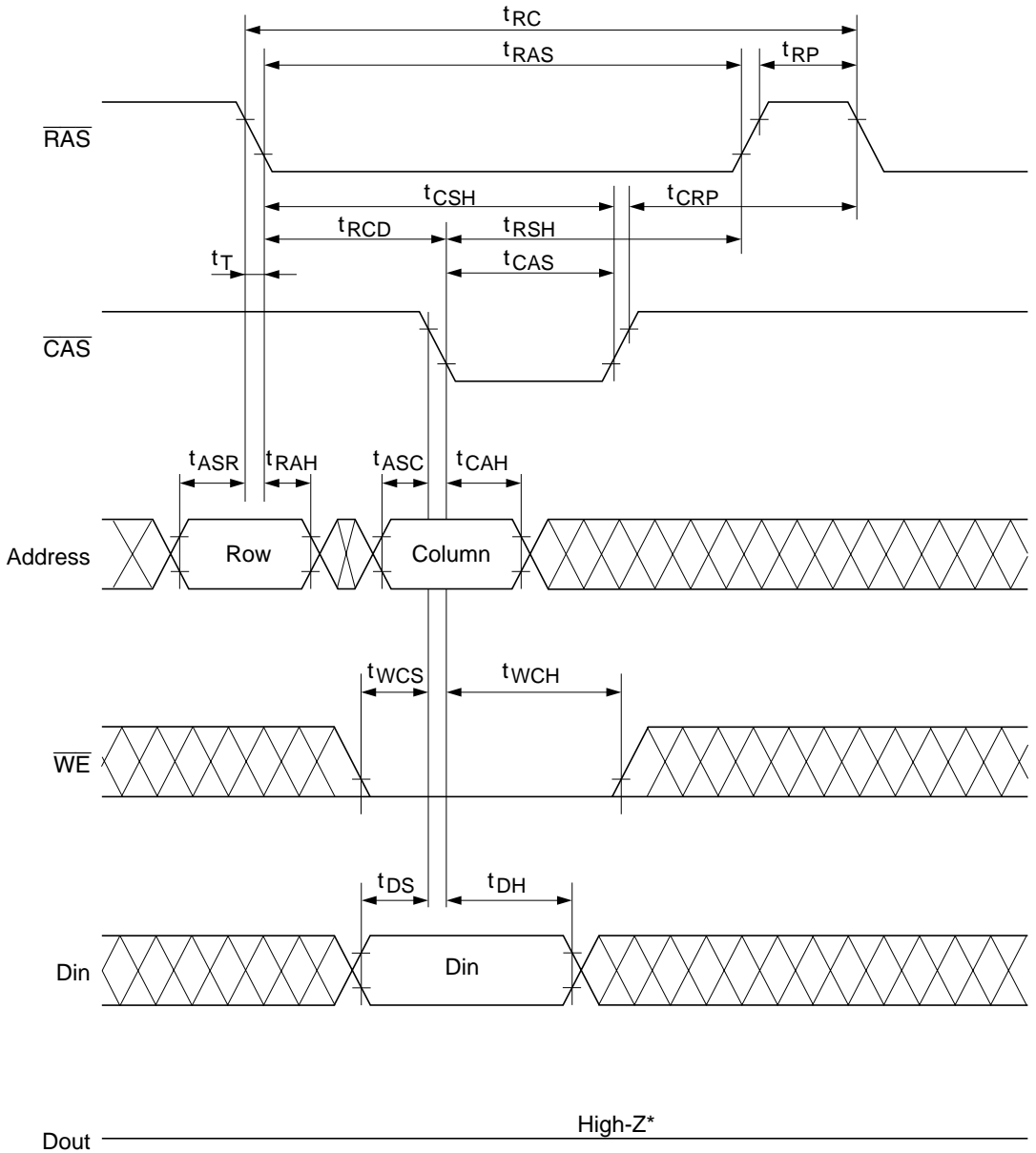

* $t_{WCS} \geq t_{WCS}(\text{min})$

HM5164800A Series, HM5165800A Series

Delayed Write Cycle*18

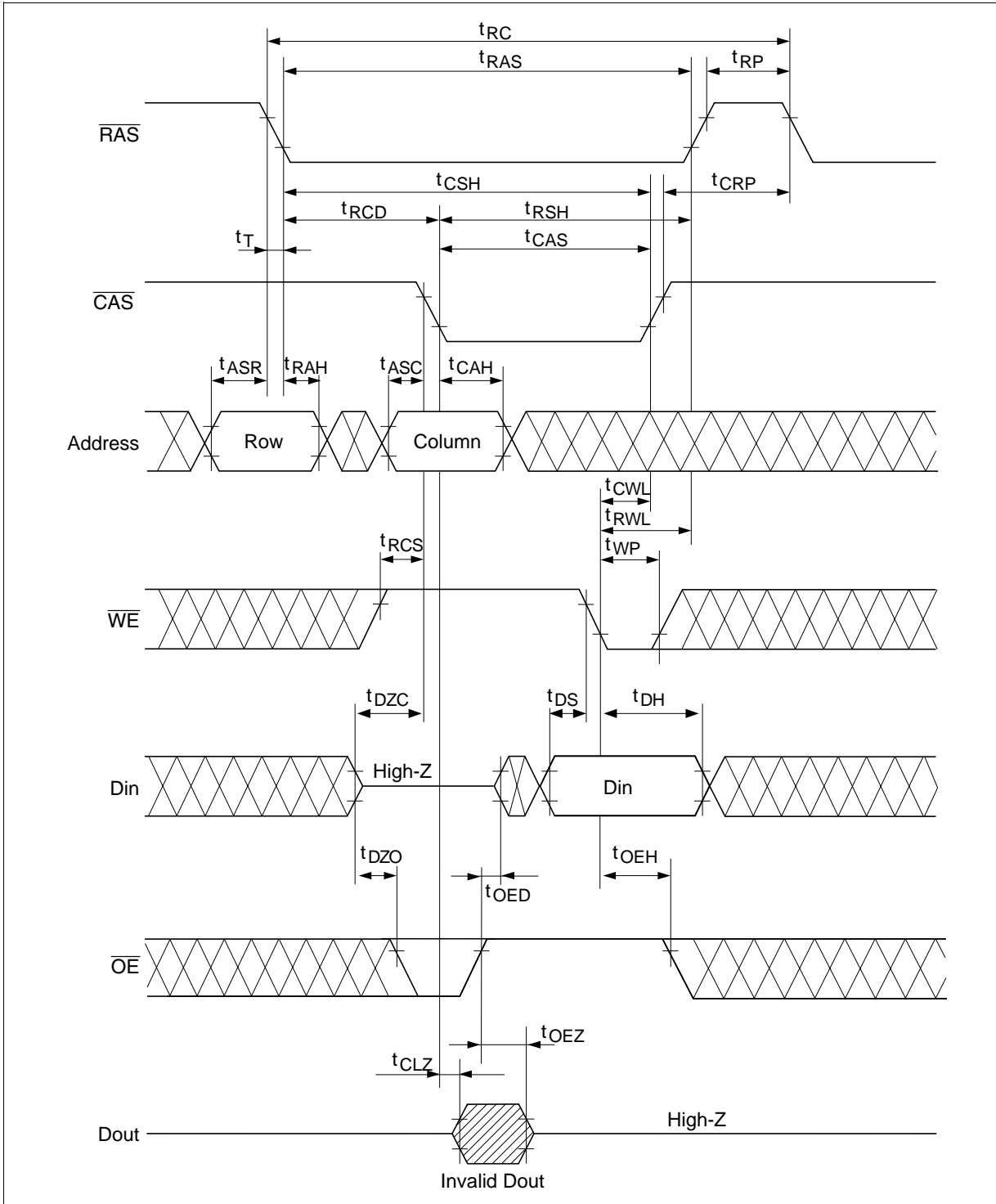

Read-Modify-Write Cycle*18

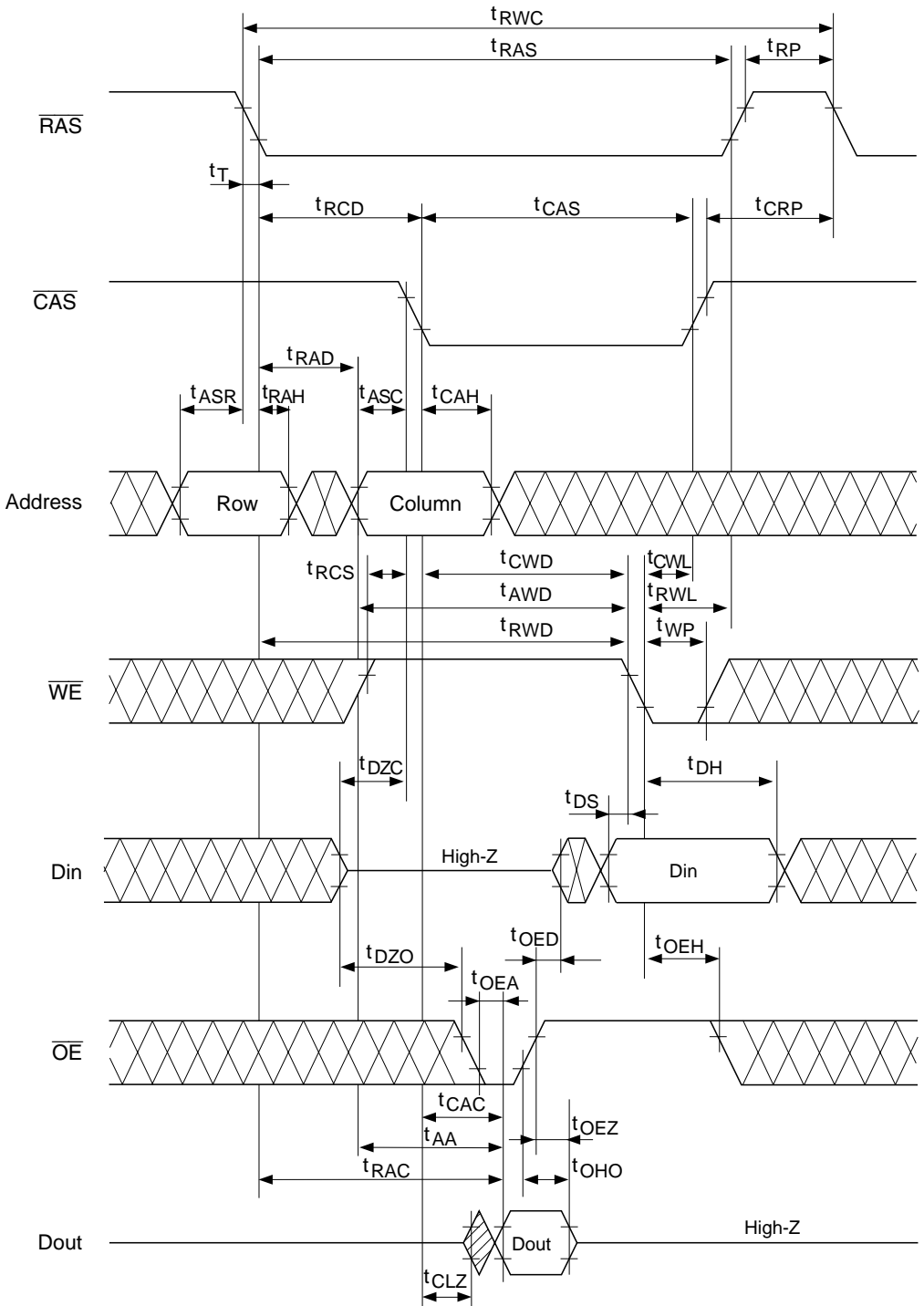

$\overline{\text{RAS}}$ -Only Refresh Cycle

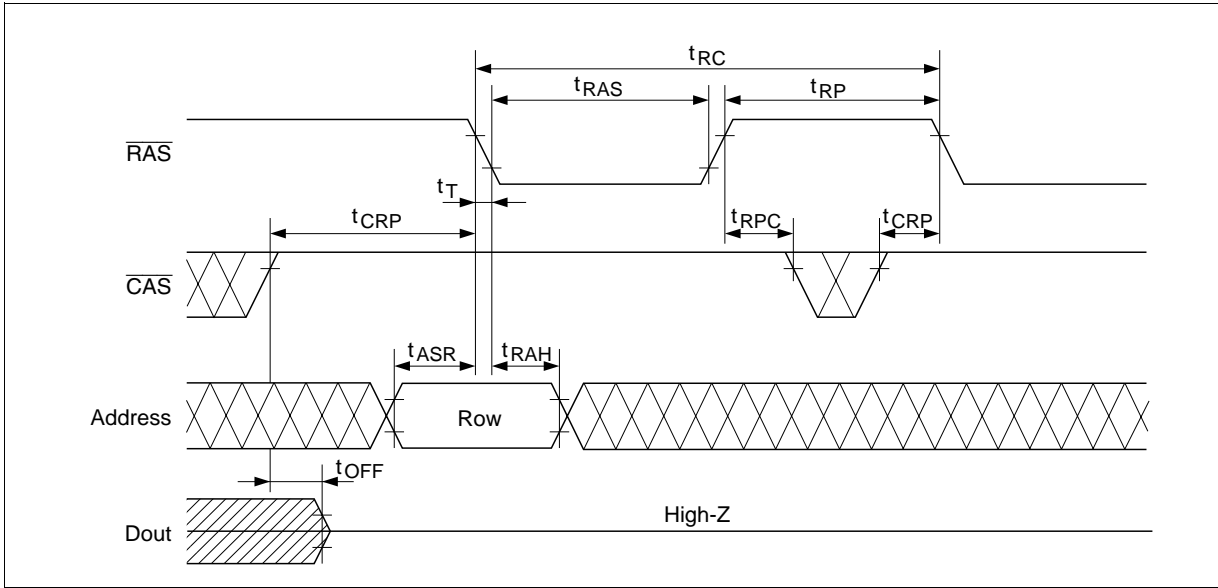

$\overline{\text{CAS}}$ -Before- $\overline{\text{RAS}}$ Refresh Cycle

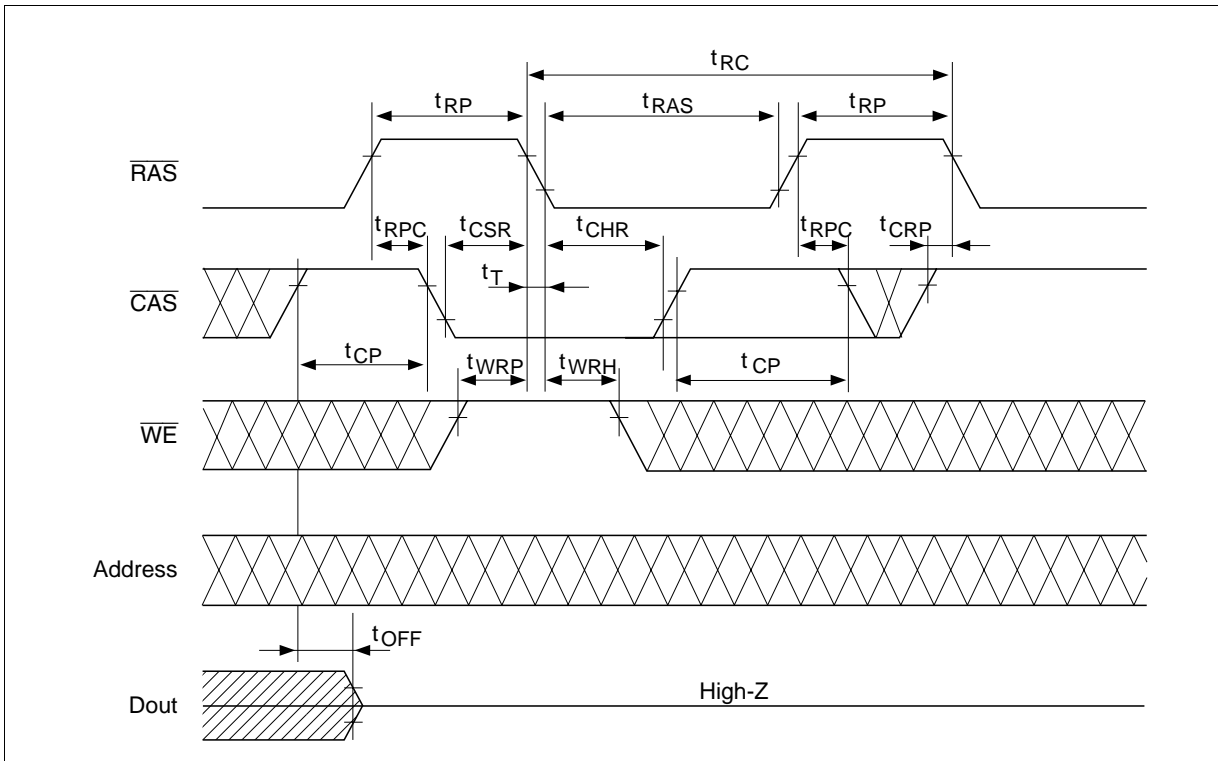

Hidden Refresh Cycle

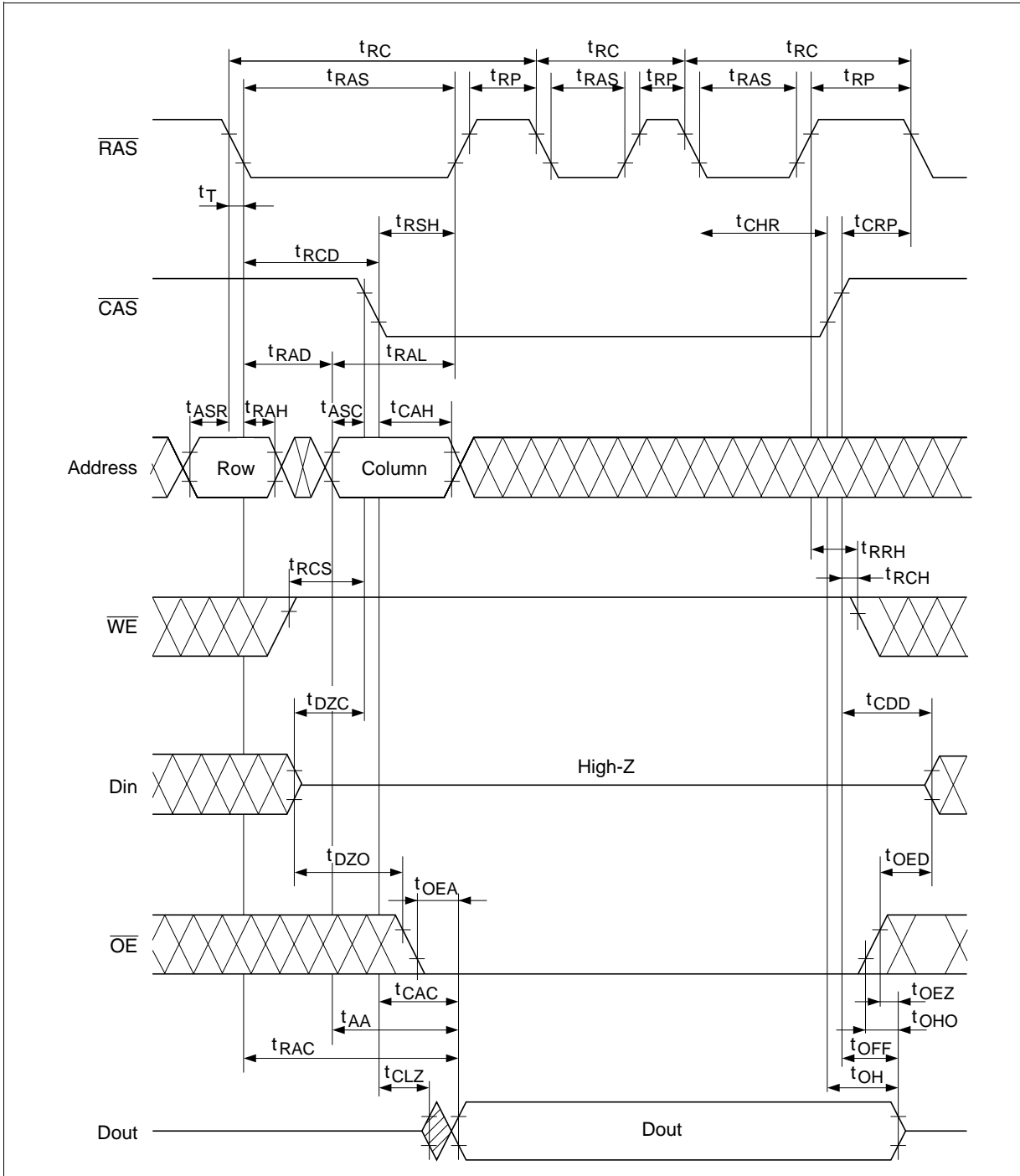

HM5164800A Series, HM5165800A Series

Fast Page Mode Read Cycle

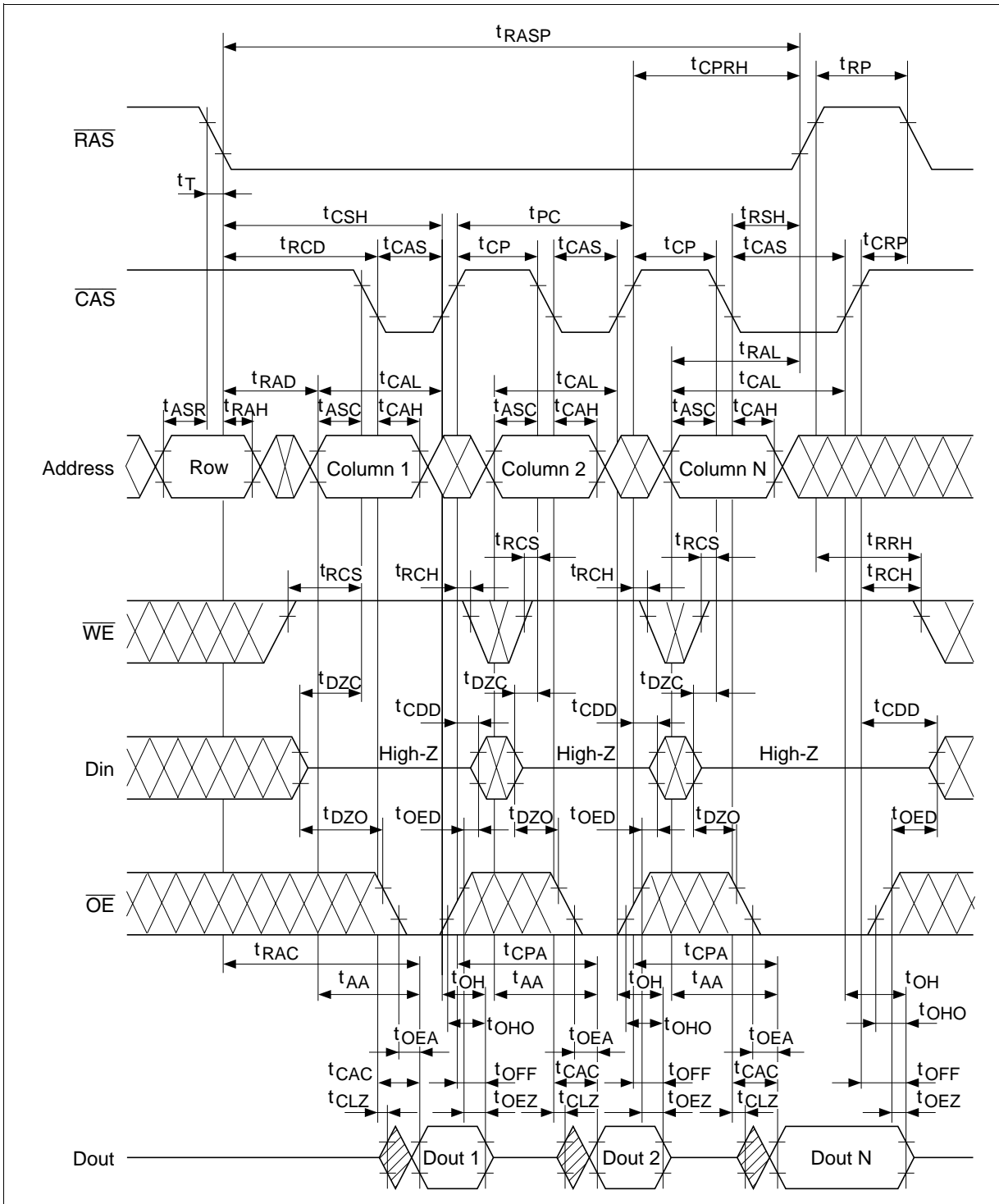

Fast Page Mode Early Write Cycle

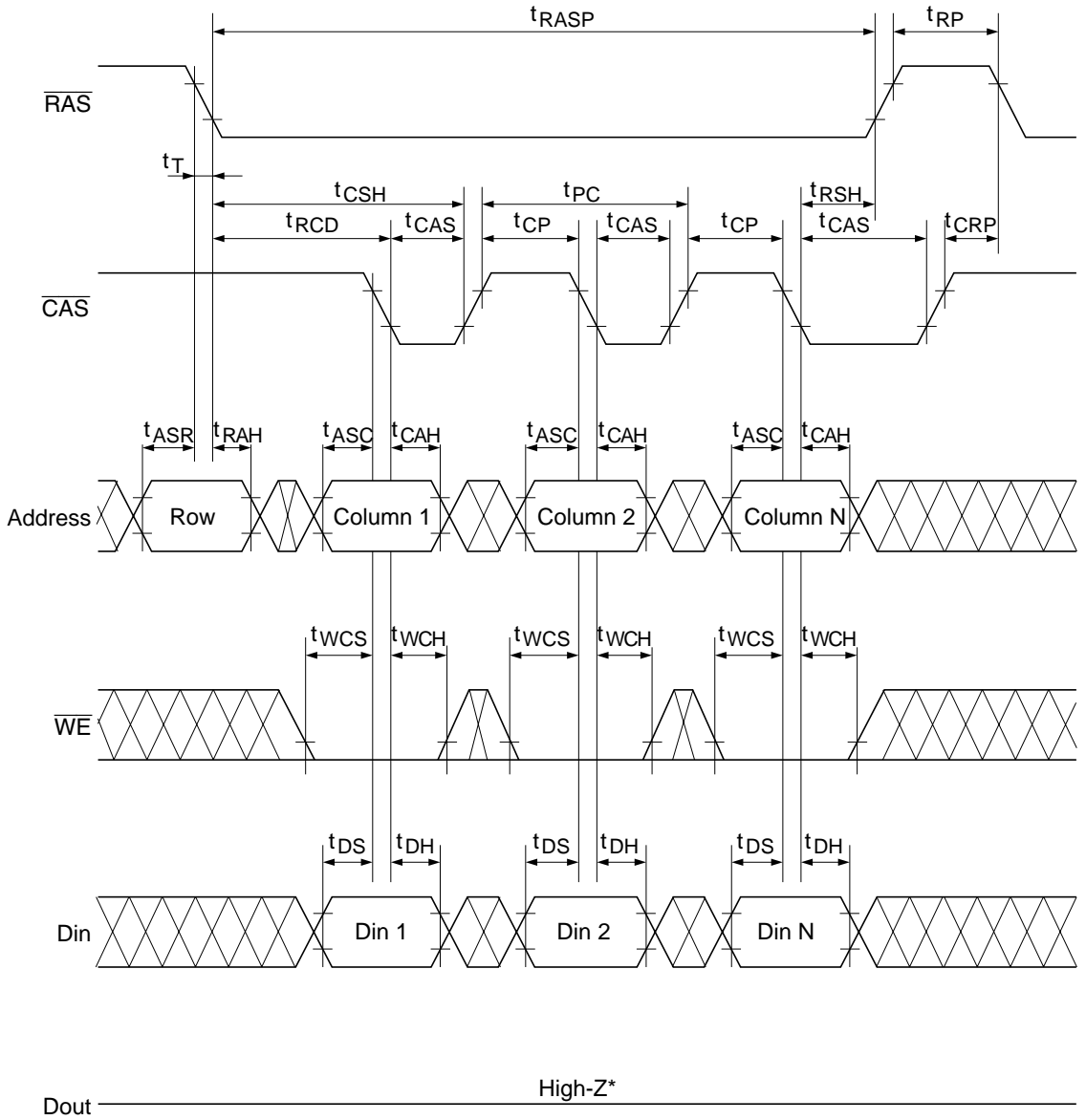

* $t_{wcs} \geq t_{wcs}(\text{min})$

HM5164800A Series, HM5165800A Series

Fast Page Mode Delayed Write Cycle*18

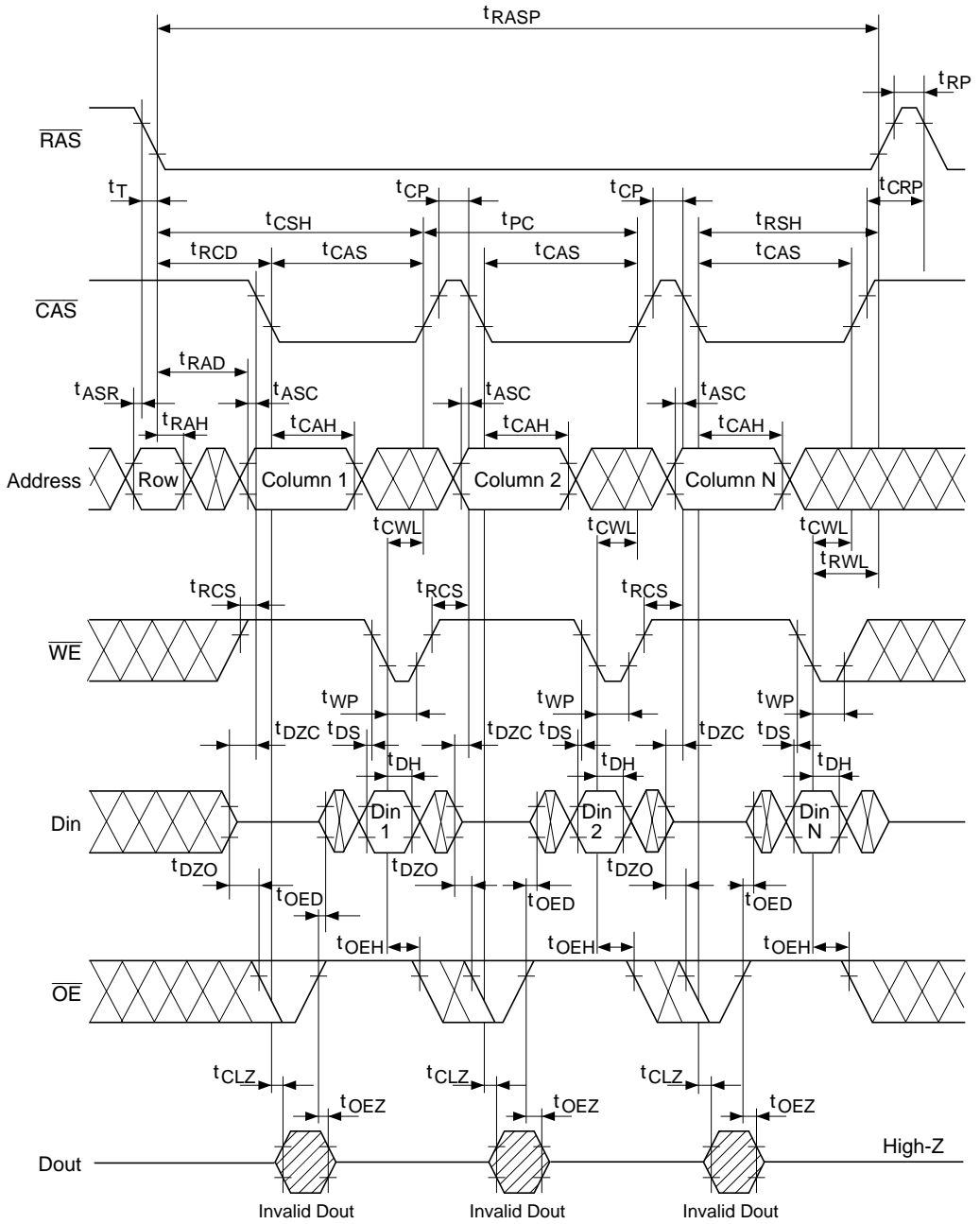

Fast Page Mode Read-Modify-Write Cycle*18

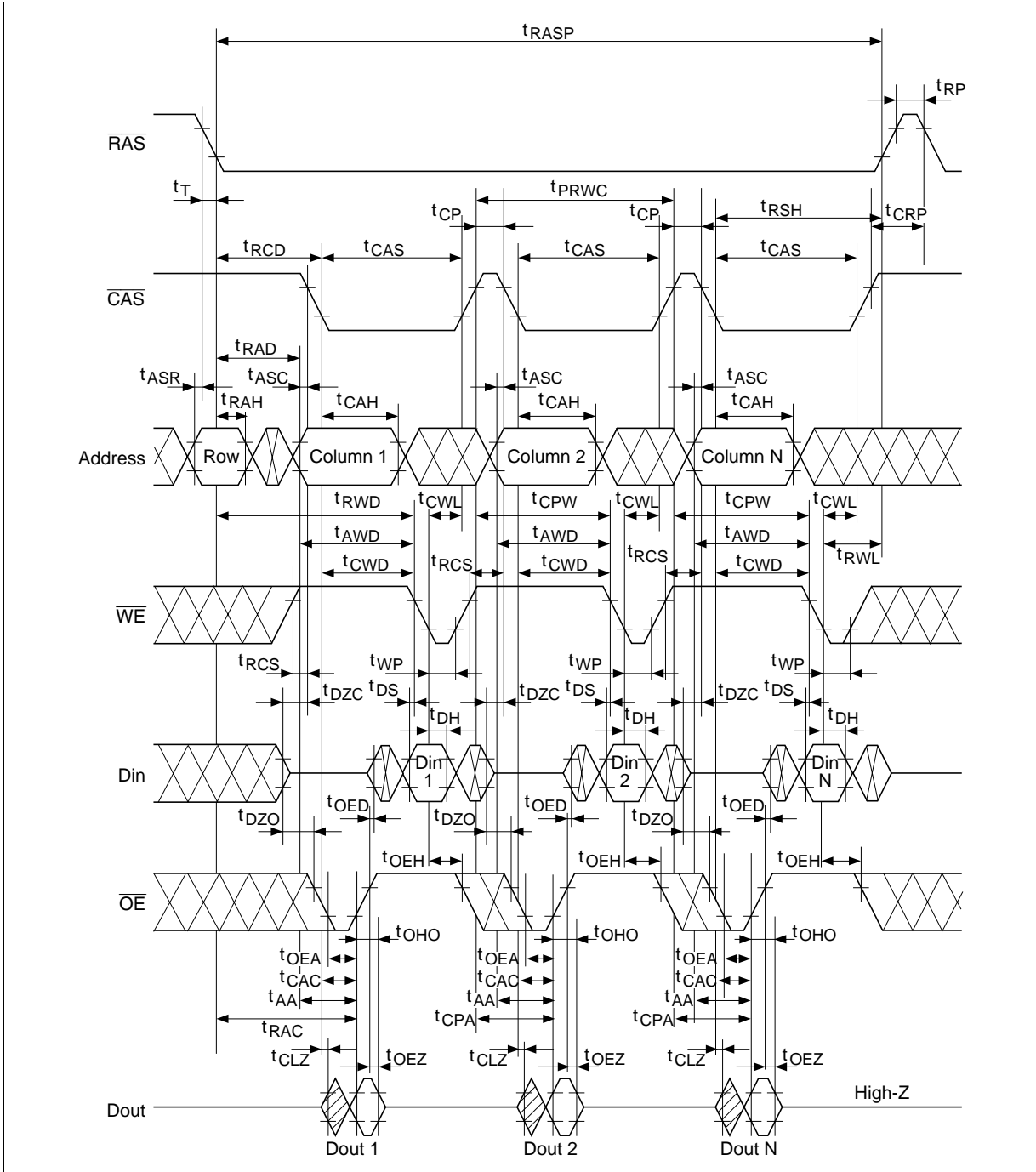

HM5164800A Series, HM5165800A Series

Self Refresh Cycle (L-version)*^{20, 21, 22}

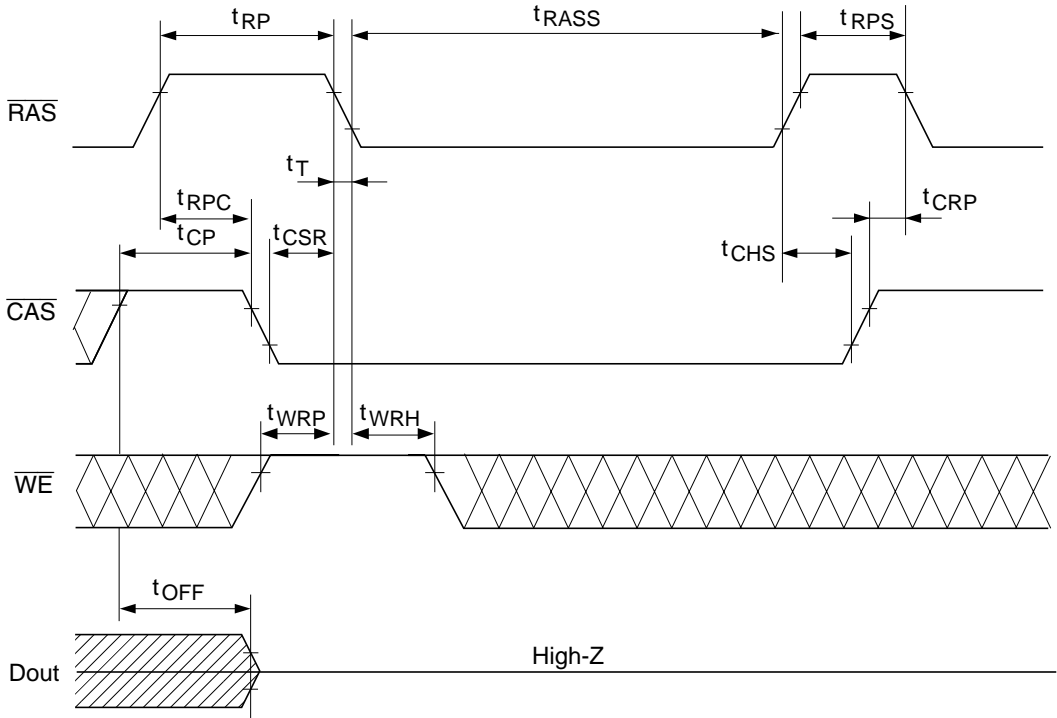

Package Dimensions

HM5164800AJ/ALJ Series

HM5165800AJ/ALJ Series (CP-32DC)

Unit: mm

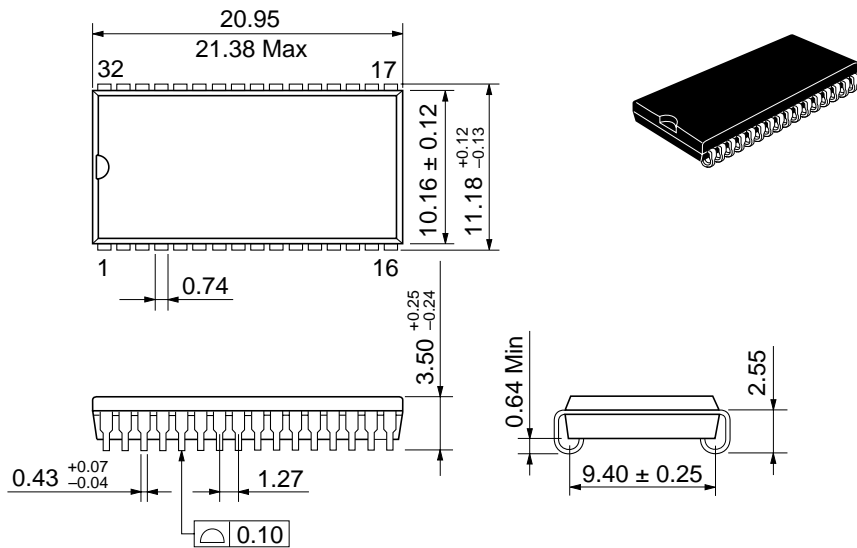

HM5164800A Series, HM5165800A Series

HM5164800ATT/ALTT Series

HM5165800ATT/ALTT Series (TTP-32DC)

Unit: mm

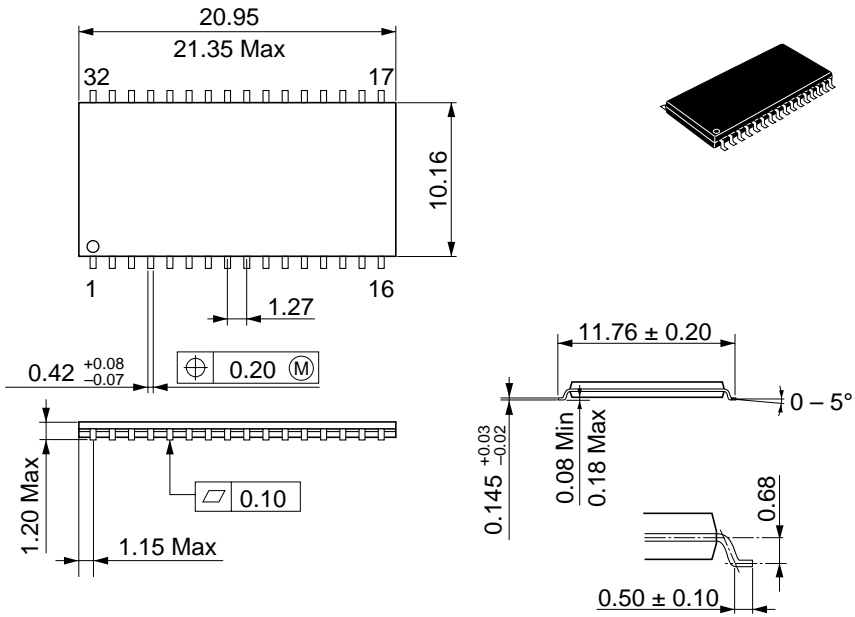

When using this document, keep the following in mind:

1. This document may, wholly or partially, be subject to change without notice.
2. All rights are reserved: No one is permitted to reproduce or duplicate, in any form, the whole or part of this document without Hitachi's permission.
3. Hitachi will not be held responsible for any damage to the user that may result from accidents or any other reasons during operation of the user's unit according to this document.
4. Circuitry and other examples described herein are meant merely to indicate the characteristics and performance of Hitachi's semiconductor products. Hitachi assumes no responsibility for any intellectual property claims or other problems that may result from applications based on the examples described herein.
5. No license is granted by implication or otherwise under any patents or other rights of any third party or Hitachi, Ltd.
6. **MEDICAL APPLICATIONS:** Hitachi's products are not authorized for use in **MEDICAL APPLICATIONS** without the written consent of the appropriate officer of Hitachi's sales company. Such use includes, but is not limited to, use in life support systems. Buyers of Hitachi's products are requested to notify the relevant Hitachi sales offices when planning to use the products in **MEDICAL APPLICATIONS**.

HITACHI

Hitachi, Ltd.

Semiconductor & IC Div.
Nippon Bldg., 2-6-2, Ohte-machi, Chiyoda-ku, Tokyo 100, Japan
Tel: Tokyo (03) 3270-2111
Fax: (03) 3270-5109

For further information write to:

Hitachi America, Ltd.
Semiconductor & IC Div.
2000 Sierra Point Parkway
Brisbane, CA. 94005-1835
U S A
Tel: 415-589-8300
Fax: 415-583-4207

Hitachi Europe GmbH
Electronic Components Group
Continental Europe
Dornacher Straße 3
D-85622 Feldkirchen
München
Tel: 089-9 91 80-0
Fax: 089-9 29 30 00

Hitachi Europe Ltd.
Electronic Components Div.
Northern Europe Headquarters
Whitebrook Park
Lower Cookham Road
Maidenhead
Berkshire SL6 8YA
United Kingdom
Tel: 0628-585000
Fax: 0628-778322

Hitachi Asia Pte. Ltd.
16 Collyer Quay #20-00
Hitachi Tower
Singapore 0104
Tel: 535-2100
Fax: 535-1533

Hitachi Asia (Hong Kong) Ltd.
Unit 706, North Tower,
World Finance Centre,
Harbour City, Canton Road
Tsim Sha Tsui, Kowloon
Hong Kong
Tel: 27359218
Fax: 27306071

HM5164800A Series, HM5165800A Series

Revision Record

Rev.	Date	Contents of Modification	Drawn by	Approved by
0.0	Jun. 3, 1996	Initial issue		
