



# Neuron<sup>®</sup> Chip Network Processor

## Features

- Maximum clock operation of 20 MHz, over a -40 to 85°C temperature range
- Three 8-bit pipelined processors for concurrent processing of application code and network packets
- 11-pin I/O port programmable in 34 modes for fast application program development
- Two 16-bit timer/counters for measuring and generating I/O device waveforms
- 5-pin communication port that supports direct connect and network transceiver interfaces
- 2048 bytes of SRAM for buffering network data and storing network variables
- 2048 bytes of EEPROM memory for flexible storage of application code and configuration data
- 10 KB of ROM for storing LonTalk<sup>®</sup> network protocol firmware
- Programmable pull-ups on IO4–IO7 and 20-mA sink current on IO0–IO3
- Unique 48-bit ID number in every device to facilitate network installation and management
- 32-pin SOIC or 44-pin QFP packages
- Low operating current. Sleep mode operation for reduced current consumption
- On-chip LVD circuit to prevent non-volatile memory corruption during voltage drops

- 0.35-μm Flash process technology
- 5.0V operation

## Functional Description

The CY53120 is a Neuron<sup>®</sup> Chip which implements a node for the LonWorks<sup>®</sup> distributed intelligent control networks. It incorporates, on a single chip, the necessary communication and control functions, both in hardware and firmware, that facilitate the design of a LonWorks node.

The CY53120 is manufactured using the state-of-the-art 0.35-μm Flash technology, providing to the designers the most cost-effective Neuron Chip solution.

Services at every layer of the OSI networking reference model are implemented in the LonTalk firmware-based protocol stored in the 10-KB ROM. In addition, the ROM firmware also contains preprogrammed I/O drivers, greatly simplifying application programming. The application program is stored in the EEPROM memory, and may be updated by downloading over the network.

The CY53120 contains a very flexible 5-pin communication port, that can be configured to interface to a wide variety of media transceivers at a wide range of data rates. The most common transceiver types are: twisted-pair, powerline, RF, IR, fiber-optics, and coaxial.

The CY53120 Neuron Chip is fully compatible with the Motorola MC143120E2 device.

## Logic Block Diagram

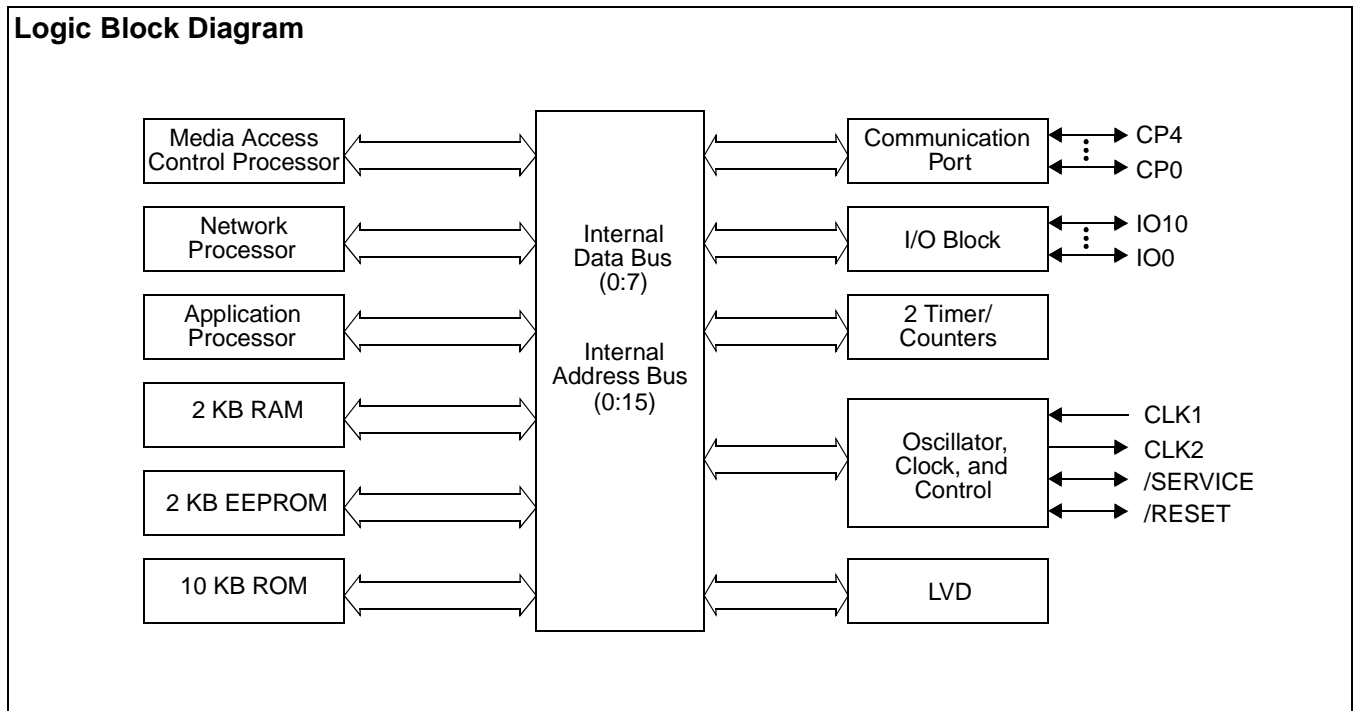

Echelon, LonWorks, LonBuilder, LonTalk, NodeBuilder, and Neuron are registered trademarks of Echelon Corporation.