

## ■ Description

FA3635P is a CMOS IC which includes low on-resistance power MOSFET for PWM-type switching power supply control. This IC achieves high efficiency DC-DC converter and it is suitable for buck converter or inverting converter with high input voltage of 10V to 50V.

## ■ Features

- Built-in low on-resistance Pch power MOSFET 50V/1.1Ω(typ.)/1A(peak)
- Wide range of 10V to 50V for input voltage
- 1.2mA low operating current as a Power IC
- Latch-mode short-circuit protection function
- Built-in over-temperature protection  
T<sub>j</sub> =125°C (min.)

## ■ Applications

- Power supply for general equipment

## ■ Dimensions, mm

### ● DIP-8

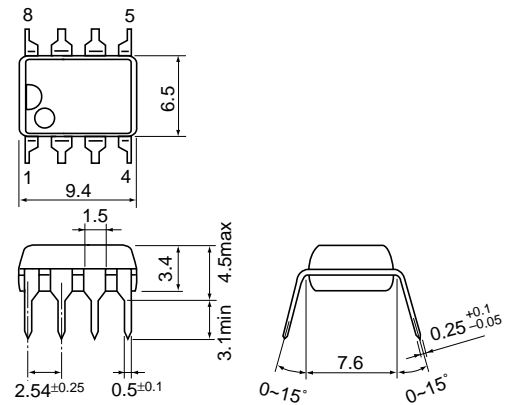

## ■ Block diagram

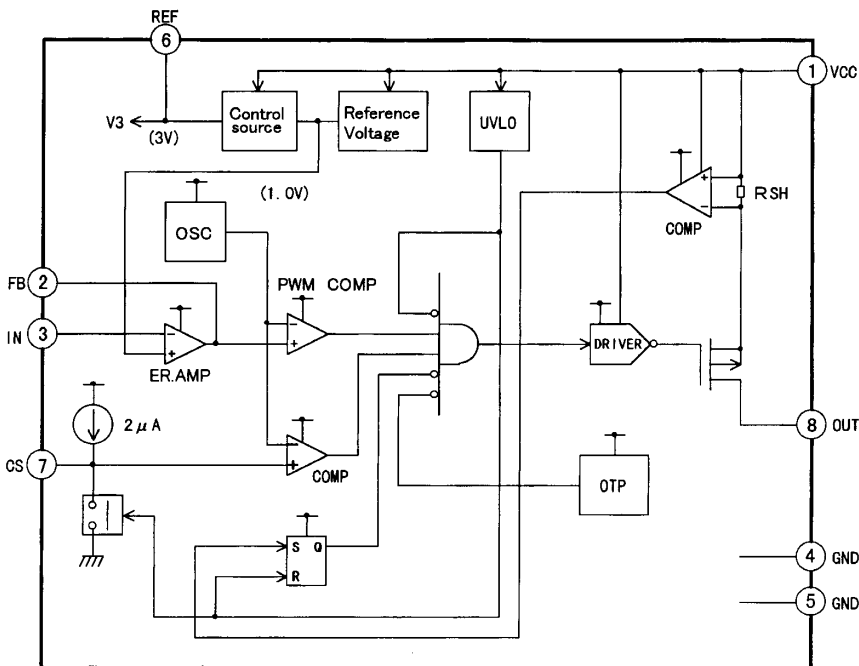

Pin No.	Pin symbol	Description
1	VCC	Power supply
2	FB	Error amplifier output
3	IN	Inverting input to error amplifier
4	GND	Ground
5	GND	Ground
6	REF	Reference voltage
7	CS	Capacitor for soft-start
8	OUT	Output

### ■ Absolute maximum ratings

Item	Symbol	Rating	Unit
Supply voltage	V <sub>CC</sub>	50.0	V
Error amplifier input voltage	V <sub>IN</sub>	5.5	V
Total Power dissipation (T <sub>a</sub> = 25°C)	P <sub>d</sub>	1.1	W
Junction temperature	T <sub>j</sub>	125	°C
Operating temperature	T <sub>op</sub>	-20 to +85°C	°C
Storage temperature	T <sub>stg</sub>	-40 to +150	°C

### ■ Recommended operating conditions

Item	Symbol	Min.	Max.	Unit
Supply voltage	V <sub>CC</sub>	10.0	45.0	V
REF terminal by-pass capacitor	C <sub>REF</sub>	0.047	0.22	μF
VCC terminal by-pass capacitor	C <sub>o</sub>	470		μF

### ■ Electrical characteristics (T<sub>a</sub>=25°C, V<sub>CC</sub>=44V, C<sub>REF</sub>=0.1μF)

#### Reference voltage section

Item	Symbol	Test condition	Min.	Typ.	Max.	Unit
terminal Voltage	V <sub>REG</sub>	C <sub>REF</sub> =0.1μF	3.00	3.12	3.24	V

#### Oscillator section

Item	Symbol	Test condition	Min.	Typ.	Max.	Unit
Oscillation frequency	f <sub>osc</sub>		70	81	100	kHz
Frequency change with supply voltage	f <sub>dV</sub>	V <sub>CC</sub> =10 to 45V		±1	±3	%
Frequency change with temperature	f <sub>dT</sub>	T <sub>a</sub> =-20 to +85°C		±3	±5	%

#### Error amplifier section

Item	Symbol	Test condition	Min.	Typ.	Max.	Unit
Input common mode voltage range	V <sub>ICOM</sub>		0.2		2.5	V
Open-loop gain	A <sub>VOL</sub>			55		dB
Unity-gain bandwidth	f <sub>T</sub>			1.0		MHz
Output sink current	I <sub>FBL</sub>	Voltage follower V <sub>FB</sub> =V <sub>ref</sub> +0.05V	3.0	3.8		mA
Output source current	I <sub>FBH</sub>	Voltage follower V <sub>FB</sub> =V <sub>ref</sub> -0.05V		-140	-100	μA
Reference Voltage	V <sub>ref</sub>	Voltage follower V <sub>CC</sub> =10 to 45V T <sub>a</sub> =-20 to +85°C	0.97	1.00	1.03	V
Input threshold voltage (Pin 2)	V <sub>FB 0</sub>	Duty cycle=0%	0.5	0.6	0.7	V
	V <sub>FB 100</sub>	Duty cycle=100%	2.3	2.5	2.7	V

#### Soft-start circuit section

Item	Symbol	Test condition	Min.	Typ.	Max.	Unit
Input threshold voltage (Pin 7)	V <sub>CS 0</sub>	Duty cycle=0%	0.5	0.6	0.7	V
	V <sub>CS 100</sub>	Duty cycle=100%	2.3	2.5	2.7	V
Charge current	I <sub>CS</sub>		-2.8	-2.2	-1.6	μA

#### Undervoltage lockout circuit section

Item	Symbol	Test condition	Min.	Typ.	Max.	Unit
Operating voltage	V <sub>UVLO</sub>		5.0	6.1	8.5	V

**Overheat protection section**

Item	Symbol	Test condition	Min.	Typ.	Max.	Unit
Operating temperature	$T_{OH}$		125	135	145	°C
Hysteresis width	$\Delta T_{OH}$		45	50	55	°C

**Output section**

Item	Symbol	Test condition	Min.	Typ.	Max.	Unit
Voltage drop	$V_{DROP}$	$I_{OUT}=1.0A$ $I_{OUT}=0.7A$ $I_{OUT}=0.1A$		1.1 0.7 0.1	1.4 0.9 0.2	V
Overcurrent limit	$I_{OLMT}$	Peak current	1.0	1.75	2.0	A

**Overall device**

Item	Symbol	Test condition	Min.	Typ.	Max.	Unit
Operating current	$I_{CC}$	Out pin open, $V_{CC}=44V$ Duty cycle=100%		0.9	4.0	mA

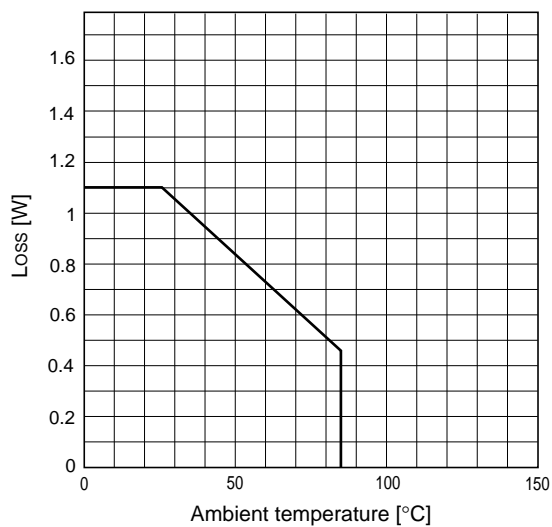
**■ Characteristic curve****● Thermal characteristic**

Thermal resistance :  $\theta_{j-c}$ (Junction to case) = 30°C/W  
 $\theta_{j-a}$ (Junction to air) = 90°C/W

■ Characteristic curves (Ta=25°C)

Output duty cycle vs. FB terminal voltage (VFB)

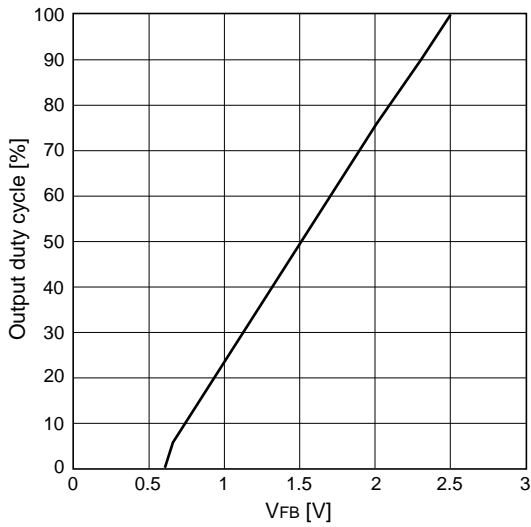

Output duty cycle vs. CS terminal voltage (Vcs)

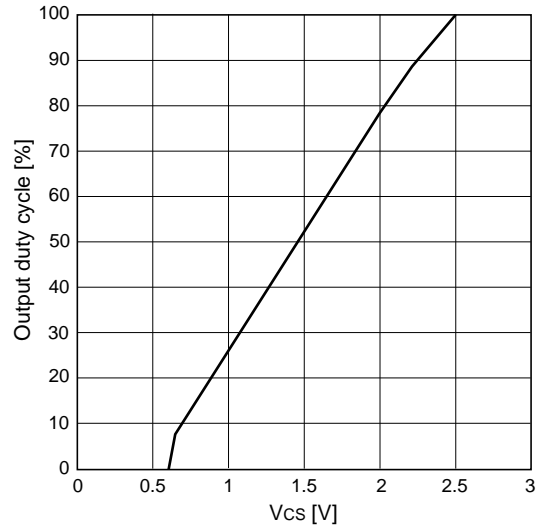

Oscillation frequency (fosc) vs. ambient temperature (Ta)

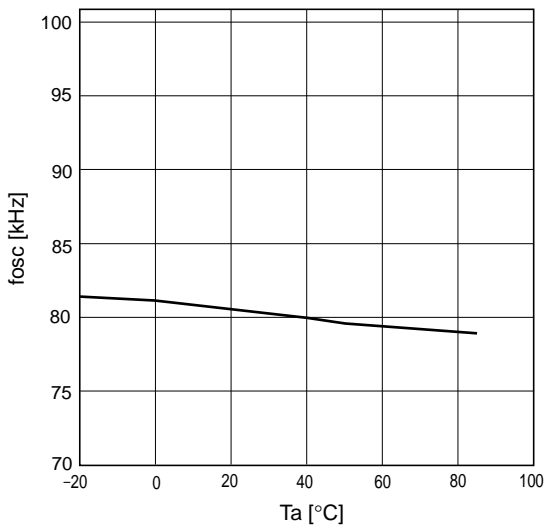

Reference voltage (VREF) vs. ambient temperature (Ta)

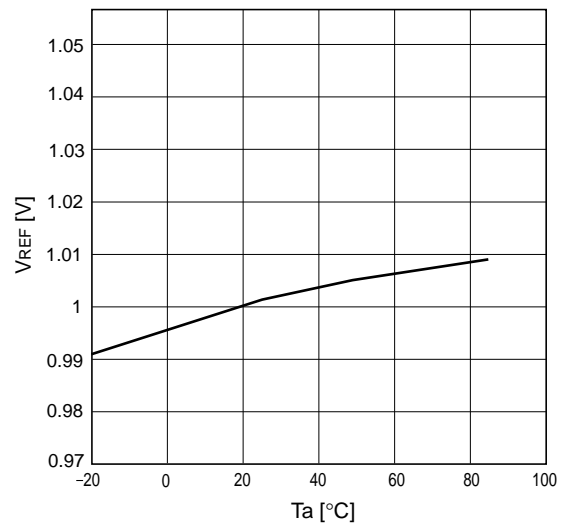

Output voltage (Vout) vs. output current (Iout)

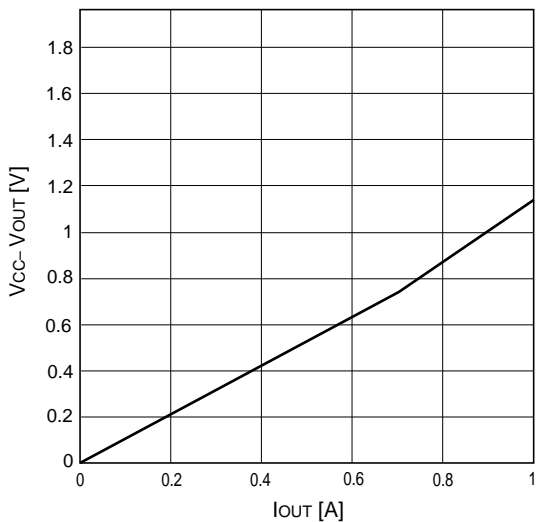

Supply current (Icc) vs. supply voltage (Vcc)

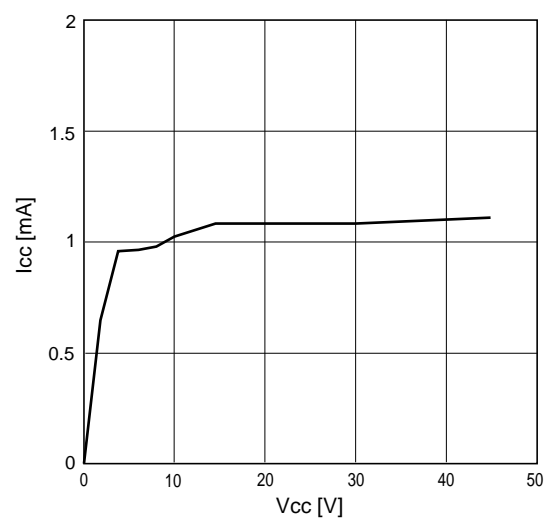

Error amplifier voltage gain ( $A_v$ ) / phase ( $\theta$ ) vs. frequency ( $f$ )

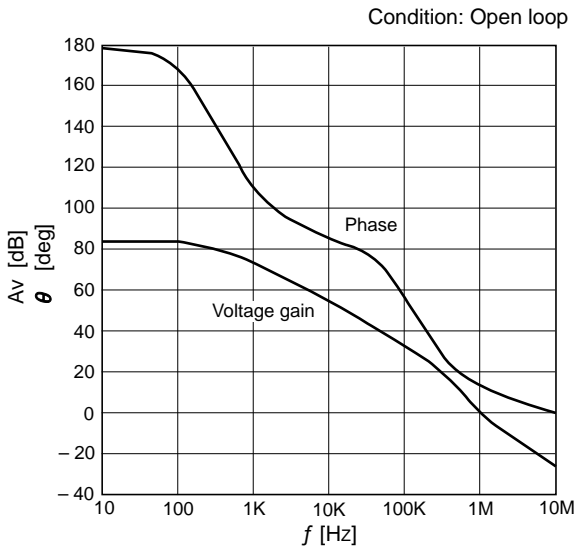

■ Application circuit

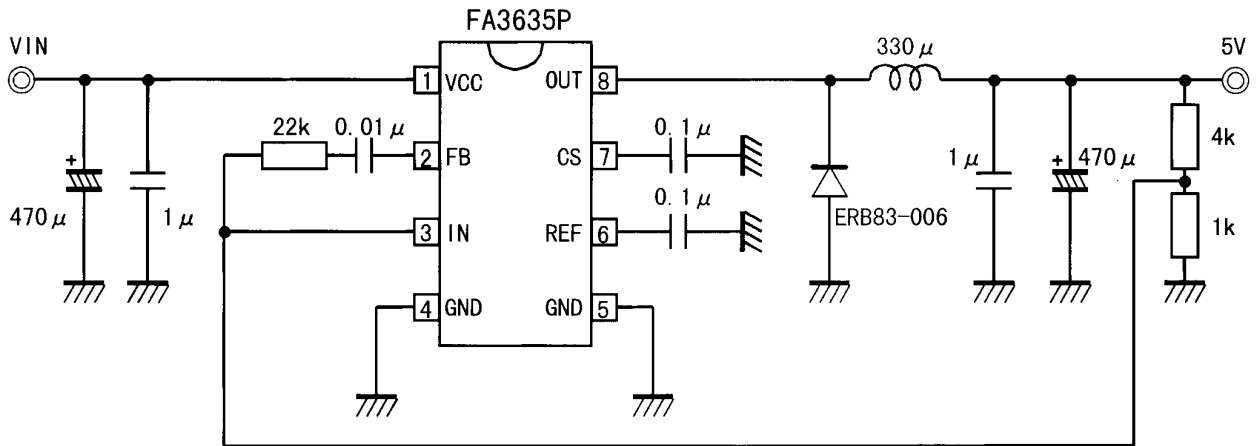

Parts tolerances characteristics are not defined in the circuit design sample shown above. When designing an actual circuit for a product, you must determine parts tolerances and characteristics for safe and economical operation.