

Power Factor and PWM Controller (Voltage Mode)

October 1995

FEATURES

- PFC and PWM Single Chip Solution
- Synchronized Operation up to 300kHz
- 99% Power Factor over 20:1 Load Current Range
- Voltage Mode PWM
- Instantaneous Overvoltage Protection
- Dedicated Overvoltage Protection (OVP Pin)
- Minimal Line Current Dead Zone
- Typical 250µA Start-Up Supply Current
- Line Switching Noise Filter
- Low Quiescent Current: 13mA
- Fast 1.5A Peak Current Gate Drivers
- Separate Soft-Start Control

APPLICATIONS

- Universal Power Factor Corrected Power Supplies and Preregulators

DESCRIPTION

The LT[®] 1508 is a complete solution for universal off-line switching power supplies utilizing active power factor correction. The PFC section is identical to the LT1248 PFC controller except the EN/SYNC pin is removed because PFC and PWM are synchronized internally.

The voltage mode PWM section (LT1509 is the current mode counterpart) contains all the primary side functions to convert the PFC preregulated high voltage output to an isolated low voltage output. The PWM duty cycle is internally limited to 47% (maximum 50%) to prevent transformer saturation. PWM soft start begins when PFC output reaches the preset voltage. In the event of brief line loss, PWM will be shut off when the PFC output voltage drops below 73% of the preset value.

LT, LTC and LT are registered trademarks of Linear Technology Corporation.

BLOCK DIAGRAM

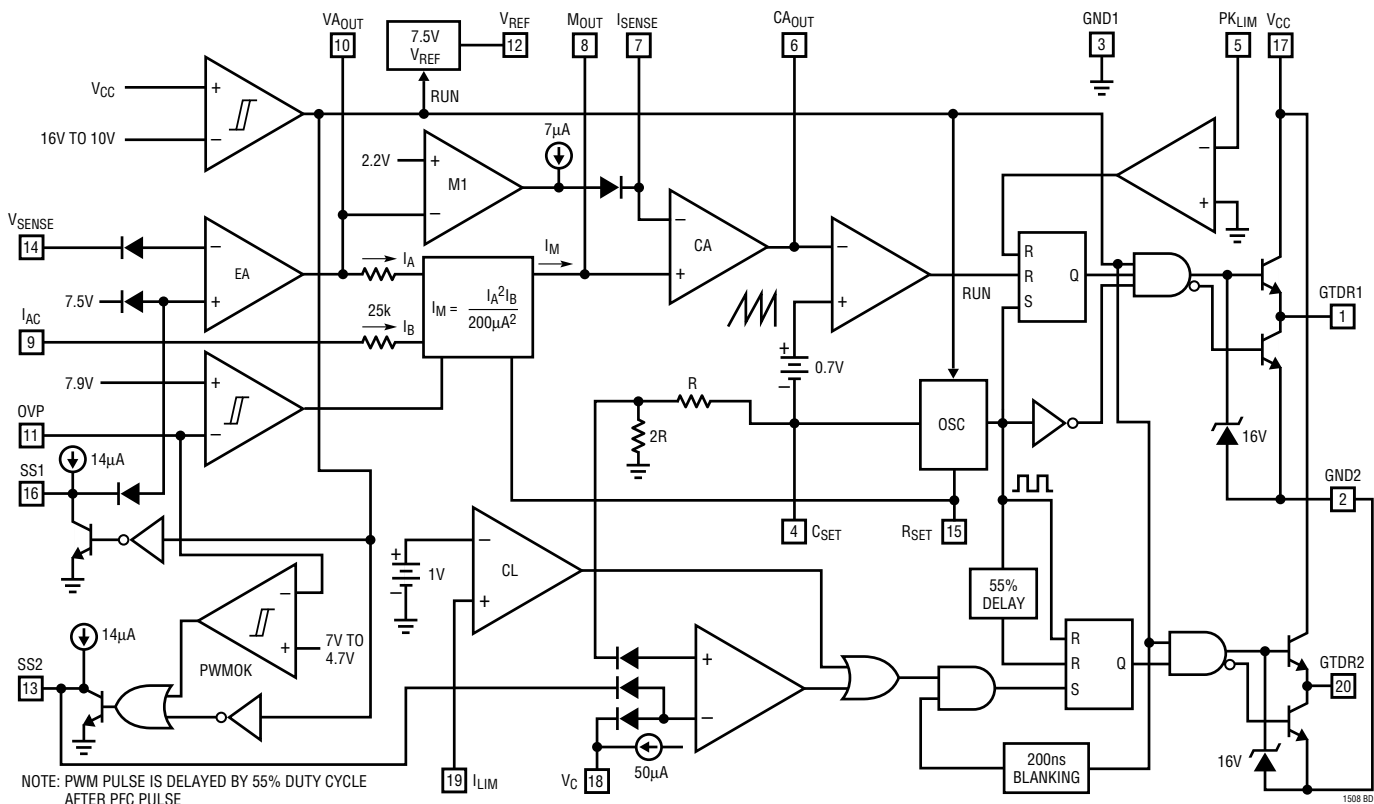

DESCRIPTION

By using fixed high frequency PWM current averaging without the need for slope compensation, the LT1508 achieves far lower line current distortion with a smaller magnetic element than systems that use either peak current detection, or zero current switching approach, in both continuous and discontinuous modes of operation. The LT1508 also provides filtering capability to reject line

switching noise which can cause instability when fed into the multiplier. Line current dead zone is minimized with low bias voltage at the current input to the multiplier. The LT1508 provides many protection features including peak current limiting and overvoltage protection. Implemented with a very high speed process, the LT1508 can be operated at frequencies as high as 300kHz.

ABSOLUTE MAXIMUM RATINGS

Supply Voltage	27V
GTDR Current Continuous	0.5A
GTDR Output Energy	5 μ J
I _{AC} , R _{SET} , PK _{LIM} Input Current	20mA
V _{SENSE} , OVP Input Voltage	V _{MAX}
I _{LIM} , V _C Input Voltage	8V
I _{SENSE} , M _{OUT} Input Current	\pm 5mA
Operating Junction Temperature Range	
Commercial	0°C to 100°C
Industrial	-40°C to 125°C
Thermal Resistance (Junction-to-Ambient)	
N Package	100°C/W
SW Package	120°C/W

PACKAGE/ORDER INFORMATION

TOP VIEW		ORDER PART NUMBER
GTDR1	1	20 GTDR2
GND2	2	19 I _{LIM}
GND1	3	18 V _C
C _{SET}	4	17 V _{CC}
PK _{LIM}	5	16 SS1
CA _{OUT}	6	15 R _{SET}
I _{SENSE}	7	14 V _{SENSE}
M _{OUT}	8	13 SS2
I _{AC}	9	12 V _{REF}
VA _{OUT}	10	11 OVP
N PACKAGE 20-LEAD PDIP		LT1508CN LT1508CS LT1508IN LT1508IS
SW PACKAGE 20-LEAD PLASTIC SO WIDE		
T _{JMAX} = 125°C, θ_{JA} = 100°C/W (N) T _{JMAX} = 125°C, θ_{JA} = 120°C/W (SW)		

Consult factory for Military grade parts.

ELECTRICAL CHARACTERISTICS

Maximum operating voltage (V_{MAX}) = 25V, V_{CC} = 18V, R_{SET} = 15k to GND, C_{SET} = 1nF to GND, I_{AC} = 100 μ A, I_{SENSE} = 0V, CA_{OUT} = 3.5V, VA_{OUT} = 5V, OVP = V_{REF}. No load on any outputs unless otherwise noted.

PARAMETER	CONDITIONS	MIN	TYP	MAX	UNITS	
Overall						
Supply Current (V _{CC} in Undervoltage Lockout)	V _{CC} = Lockout Voltage - 0.2V	●	0.25	0.45	mA	
Supply Current On	11.5V \leq V _{CC} \leq V _{MAX}	●	13	19	mA	
V _{CC} Turn-On Threshold (Undervoltage Lockout)		●	15.5	16.5	V	
V _{CC} Turn-Off Threshold		●	9.5	10.5	V	
Voltage Amplifier (PFC Section)						
Voltage Amp Offset	VA _{OUT} = 3.5V	●	-10	10	mV	
Input Bias Current	V _{SENSE} = 0V to 7V	●	-25	-250	nA	
Voltage Gain			70	100	dB	
Voltage Amp Unity-Gain Bandwidth			3		MHz	
Voltage Amp Output High (Internally Clamped)		●	11.3	13.3	V	
Voltage Amp Output Low		●	1.1	2	V	
Voltage Amp Short-Circuit Current	VA _{OUT} = 0V	●	3	8	17	mA

ELECTRICAL CHARACTERISTICS

Maximum operating voltage (V_{MAX}) = 25V, V_{CC} = 18V, R_{SET} = 15k to GND, C_{SET} = 1nF to GND, I_{AC} = 100 μ A, I_{SENSE} = 0V, CA_{OUT} = 3.5V, VA_{OUT} = 5V, OVP = V_{REF} . No load on any outputs unless otherwise noted.

PARAMETER	CONDITIONS		MIN	TYP	MAX	UNITS
Current Amplifier (PFC Section)						
Current Amp Offset Voltage		●		±1	±4	mV
I_{SENSE} Bias Current		●		-25	-250	nA
Current Amp Voltage Gain			80	110		dB
Current Amp Unity-Gain Bandwidth				3		MHz
Current Amp Output High		●	7.2	8.5		V
Current Amp Output Low		●		1.1	2	V
Current Amp Short-Circuit Current	$CA_{OUT} = 0V$	●	3	8	17	mA
Input Range, I_{SENSE} , M_{OUT} (Linear Operation)		●	-0.3		1	V
Reference						
Reference Output Voltage	$I_{REF} = 0mA$, $T_A = 25^\circ C$		7.39	7.50	7.60	V
V_{REF} Load Regulation	$-5mA < I_{REF} < 0mA$			5		mV
V_{REF} Line Regulation	$11.5V < V_{CC} < V_{MAX}$	●	-20	5	20	mV
V_{REF} Short-Circuit Current	$V_{REF} = 0V$	●	12	28	50	mA
V_{REF} Worst Case	Load, Line, Temperature	●	7.32	7.5	7.68	V
Current Limit						
PK_{LIM} Offset Voltage		●	-25		25	mV
PK_{LIM} Input Current	$PK_{LIM} = -0.1V$	●		-50	-100	μ A
PK_{LIM} to GTDR Propagation Delay	PK_{LIM} Falling from 50mV to -50mV			400		ns
Multiplier						
Multiplier Output Current	$I_{AC} = 100\mu A$, $R_{SET} = 15k$			35		μ A
Multiplier Output Current Offset	$R_{AC} = 1M$ from I_{AC} to GND	●		-0.05	-0.5	μ A
Multiplier Maximum Output Current	$I_{AC} = 450\mu A$, $R_{SET} = 15k$, $VA_{OUT} = 7V$, $M_{OUT} = 0V$	●	-286	-260	-235	μ A
Multiplier Gain Constant (Note 1)				0.035		V^{-2}
I_{AC} Input Resistance	I_{AC} from 50 μ A to 1mA		15	25	35	k Ω
Oscillator						
Oscillator Frequency	$R_{SET} = 15k$, $C_{SET} = 1000pF$	●	85	100	115	kHz
	$R_{SET} = 15k$, $C_{SET} = 1500pF$	●	58	68	78	kHz
C_{SET} Ramp Peak-to-Peak Amplitude			4.35	4.7	5.0	V
C_{SET} Ramp Valley Voltage			1.15	1.3	1.55	V
Overvoltage Comparator (PFC Section)						
Comparator Trip Voltage Ratio (V_{TRIP}/V_{REF})		●	1.04	1.05	1.06	
Hysteresis				0.35		V
OVP Bias Current	$OVP = 7.5V$	●		0.2	1	μ A
OVP Propagation Delay				100		ns
Gate Drivers (GTDR1 and GTDR2)						
Max Output Voltage	0mA Load, $18V < V_{CC}$	●	12	15	17.5	V
Output High	-200mA Load, $11.5V \leq V_{CC} \leq 15V$	●	$V_{CC} - 3.0$			V
Output Low (Device Unpowered)	$V_{CC} = 0V$, 50mA Load (Sinking)	●		0.9	1.5	V
Output Low (Device Active)	200mA Load (Sinking)	●		0.5	1	V
	10mA Load	●		0.2	0.4	V
Peak Output Current	10nF from GTDR to GND			2		A
Rise and Fall Time	1nF from GTDR to GND			25		ns
Max Duty Cycle (PFC)			90	96		%
Max Duty Cycle (PWM) (Note 2)			44		50	%

ELECTRICAL CHARACTERISTICS

$V_{CC} = 18V$, $R_{SET} = 15k$ to GND, $C_{SET} = 1nF$ to GND, $I_{AC} = 100\mu A$, $I_{SENSE} = 0V$, $CA_{OUT} = 3.5V$, $VA_{OUT} = 5V$, $OVP = V_{REF}$. No load on any outputs, unless otherwise noted.

PARAMETER	CONDITIONS		MIN	TYP	MAX	UNITS
Soft-Start Current						
SS1 Current (PFC)	SS1 = 2.5V	●	5	12	30	μA
SS2 Current (PWM)	SS2 = 1V	●	5	12	30	μA
Comparators in PWM Section						
I_{LIM} Input Current	$I_{LIM} = 0V$, $V_C = 1.6V$	●		-0.3	-2	μA
Current Limit Comparator (CL) Threshold	$V_C > 2.6V$	●	0.95	1.1	1.20	V
GTDR2 Switching Off Threshold at V_C or at SS2	RAMP = 0V	●	1			V
V_C Input Current	$V_C = 0V$	●	-20		-80	μA
PWMOK Comparator Low Threshold (in Terms of V_{REF})		●	0.57	0.63	0.70	
V_C Pin High Voltage	1mA into V_C Pin	●	6.2	6.9	7.5	V
GTDR2 Turn-On Blanking Time				180		ns

The ● denotes specifications which apply over the full operating temperature range.

Note 1: Multiplier Gain Constant: $K = \frac{I_M}{I_{AC} (VA_{OUT} - 2)^2}$

Note 2: GTDR2 (PWM) pulse is delayed by 55% duty cycle after GTDR1 (PFC) is set.

TYPICAL PERFORMANCE CHARACTERISTICS

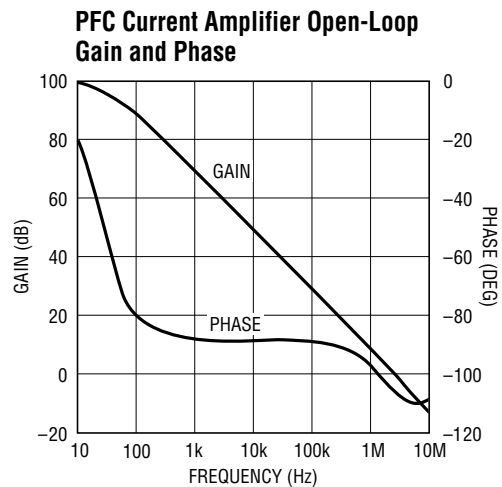
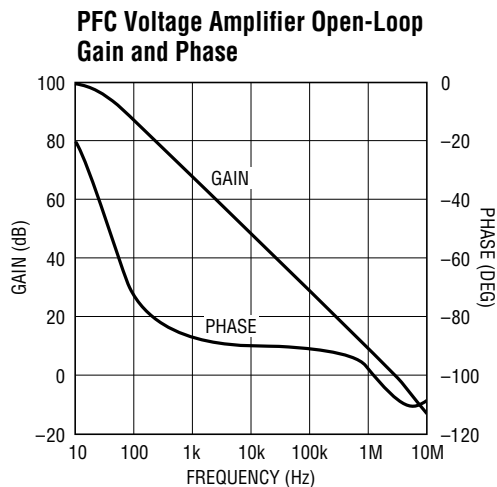

TYPICAL PERFORMANCE CHARACTERISTICS

Reference Voltage vs Temperature

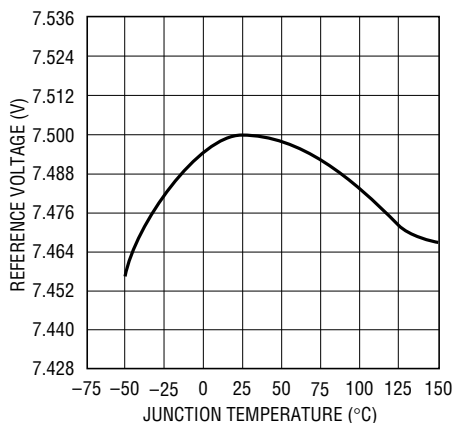

LT1508 • TPC03

Multiplier Current

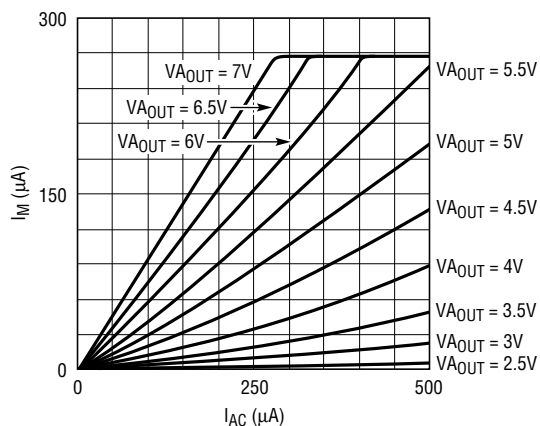

LT1508 • TPC04

Supply Current vs Supply Voltage

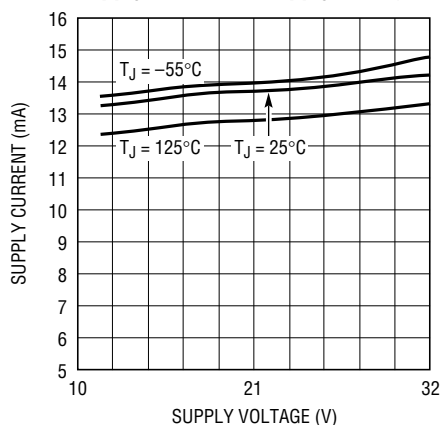

LT1508 • TPC05

GTDR Rise and Fall Time

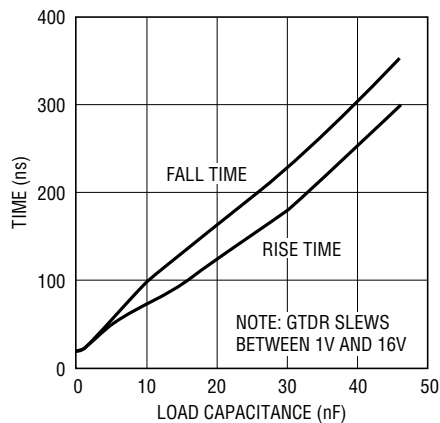

LT1508 • TPC06

Start-Up Supply Current vs Supply Voltage

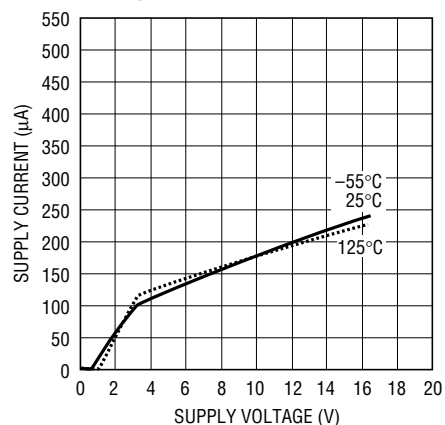

LT1508 • TPC07

Frequency vs R_{SET} and C_{SET}

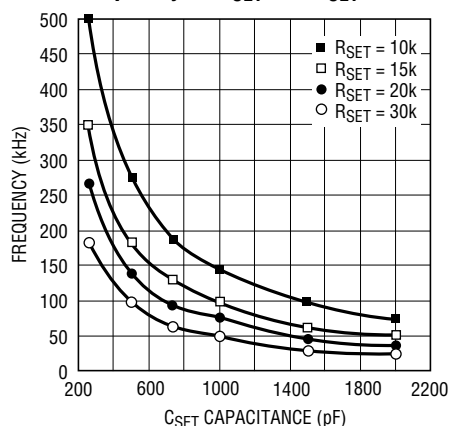

LT1508 • TPC08

GTDR1 Maximum Duty Cycle vs R_{SET} and C_{SET}

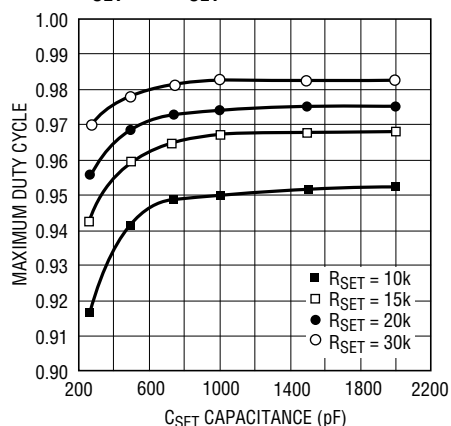

LT1508 • TPC09

M_{OUT} Pin Characteristics

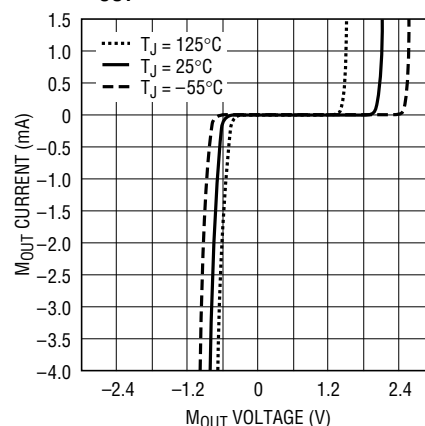

LT1508 • TPC10

TYPICAL PERFORMANCE CHARACTERISTICS

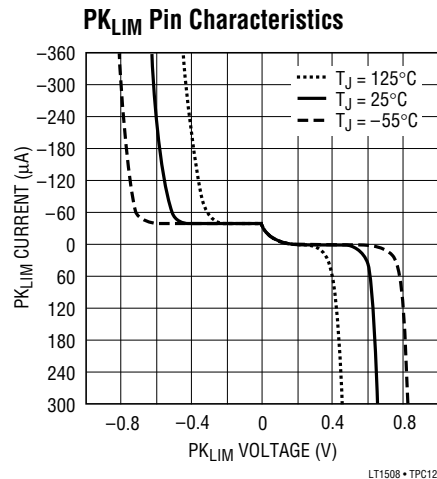
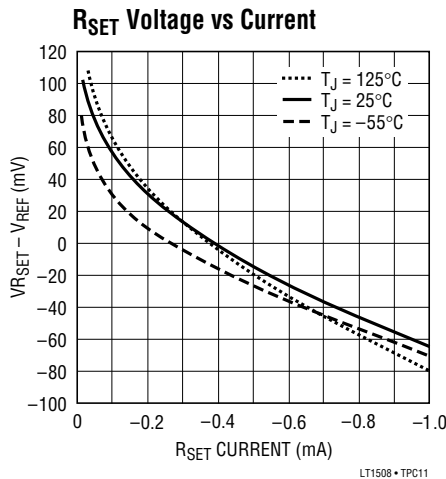

PIN FUNCTIONS (For application help with the PFC portion of this chip, see the LT1248 data sheet)

PFC SECTION

GTDR1 (Pin 1): The PFC MOSFET gate driver is a 1.5A fast totem pole output which is clamped at 15V. Capacitive loads like the MOSFET gates may cause overshoot. A gate series resistor of at least 5Ω will prevent the overshoot.

GND2 (Pin 2): Power Ground. High current spikes occur in this line when either GTDR1 or GTDR2 switches low.

GND1 (Pin 3): Analog Ground.

C_{SET} (Pin 4): The capacitor from this pin to GND and R_{SET} determines oscillator frequency. The oscillator ramp is 5V and the frequency = $1.5 / (R_{SET} C_{SET})$.

PK_{LIM} (Pin 5): The threshold of the peak current limit comparator is GND. To set current limit, a resistor divider can be connected from V_{REF} to current sense resistor.

CA_{OUT} (Pin 6): This is the output of the current amplifier that senses and forces the line current to follow the reference signal that comes from the multiplier by commanding the pulse width modulator. When CA_{OUT} is low, the modulator has zero duty cycle.

I_{SENSE} (Pin 7): This is the inverting input of the current amplifier. This pin is clamped at -0.6V by an ESD protection diode.

M_{OUT} (Pin 8): This is the multiplier high impedance current output and the noninverting input of the current amplifier. This pin is clamped at -0.6V and 3V.

I_{AC} (Pin 9): This is the AC line voltage sensing input to the multiplier. It is a current input that is biased at 2V to minimize the crossover dead zone caused by low line voltage. At the pin, a 25k resistor is in series with the current input, so that a lowpass RC can be used to filter out the switching noise coming down from the line with a high line impedance environment.

VA_{OUT} (Pin 10): This is the output of the voltage error amplifier. The output is clamped at 13.5V. When the output goes below 2.5V, the multiplier output current is zero.

OVP (Pin 11): This is the input to the overvoltage comparator. The threshold is 1.05 times the reference voltage. When the comparator trips, the multiplier, which is quickly inhibited, blanks PFC switching to prevent further overshoot. This pin is also the input to the PWMOK comparator that releases the PWM soft start (SS2) after the PFC output gets close to the final voltage and has a hysteresis of approximately 150V for 382V PFC output.

V_{REF} (Pin 12): This is the 7.5V reference. When V_{CC} goes low, V_{REF} will stay at 0V. V_{REF} biases most of the internal circuitry and can source up to 5mA externally.

V_{SENSE} (Pin 14): This is the inverting input to the voltage amplifier.

PIN FUNCTIONS (For application help with the PFC portion of this chip, see the LT1248 data sheet)

R_{SET} (Pin 15): A resistor from R_{SET} to GND sets the oscillator charging current and the maximum multiplier output current which is used to limit the maximum line current.

$$I_{M(MAX)} = 3.75V/R_{SET}$$

SS1 (Pin 16): Soft Start. SS1 is reset to zero for low V_{CC}. When V_{CC} rises above lockout threshold, SS1 is released to ramp up at a rate set by the internal 12μA current source and an external capacitor. During this ramp up, PFC reference voltage is equal to SS1 voltage. After SS1 rises past 7.5V, reference voltage remains at 7.5V.

V_{CC} (Pin 17): This is the supply for the chip. The LT1508 has two fast gate drivers required to fast charge high power MOSFET gate capacitances. Good supply bypassing is required consisting of a 0.1μF ceramic capacitor in parallel with a low ESR electrolytic capacitor (56μF or higher) in close proximity to IC GND.

PWM SECTION

SS2 (Pin 13): PWM Soft Start. The comparator PWMOK monitors the OVP pin and releases the SS2 after the PFC output gets close to the final voltage.

V_C (Pin 18): PWM voltage mode control voltage. Normally connects to the optocoupler output. A pull-up current of 50μA flows out of the pin.

I_{LIM} (Pin 19): PWM current sense input with trip point set to 1.1V.

GTDR2 (Pin 20): The PWM MOSFET gate driver is a 1.5A fast totem pole output. It is clamped at 15V. Capacitive loads like the MOSFET gates may cause overshoot. A gate series resistor of at least 5Ω will prevent the overshoot.

PACKAGE DESCRIPTION Dimension in inches (millimeters) unless otherwise noted.

N Package
20-Lead PDIP (Narrow 0.300)
 (LTC DWG # 05-08-1510)

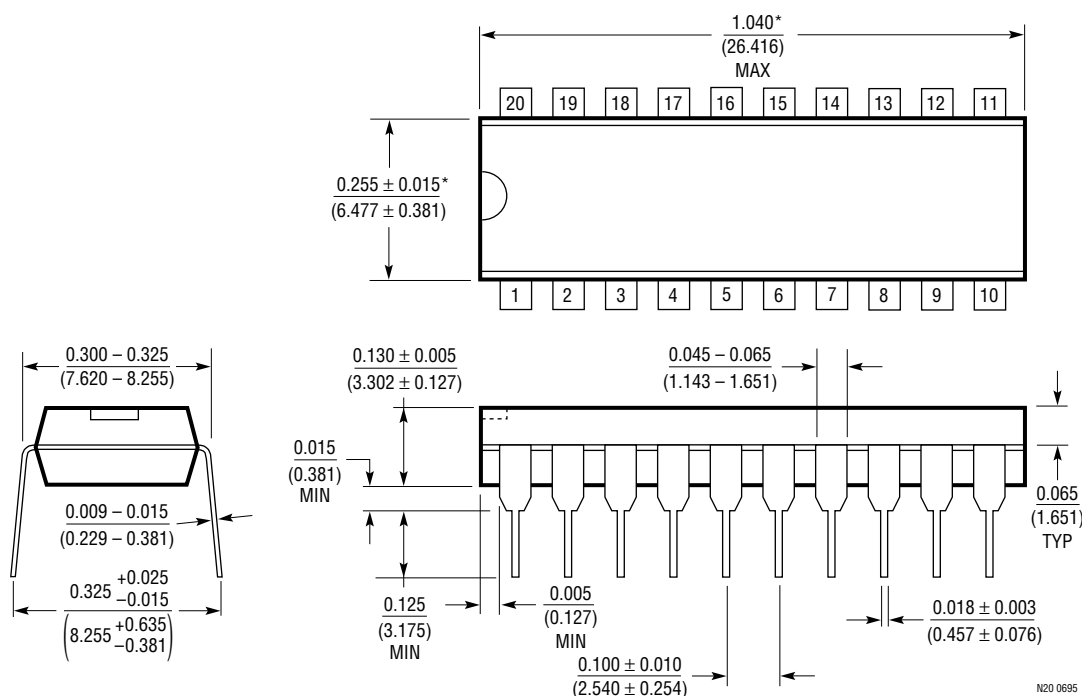

*THESE DIMENSIONS DO NOT INCLUDE MOLD FLASH OR PROTRUSIONS.
 MOLD FLASH OR PROTRUSIONS SHALL NOT EXCEED 0.010 INCH (0.254mm)

N20 0695

PACKAGE DESCRIPTION Dimension in inches (millimeters) unless otherwise noted.

SW Package
20-Lead Plastic Small Outline (Wide 0.300)
 (LTC DWG # 05-08-1620)

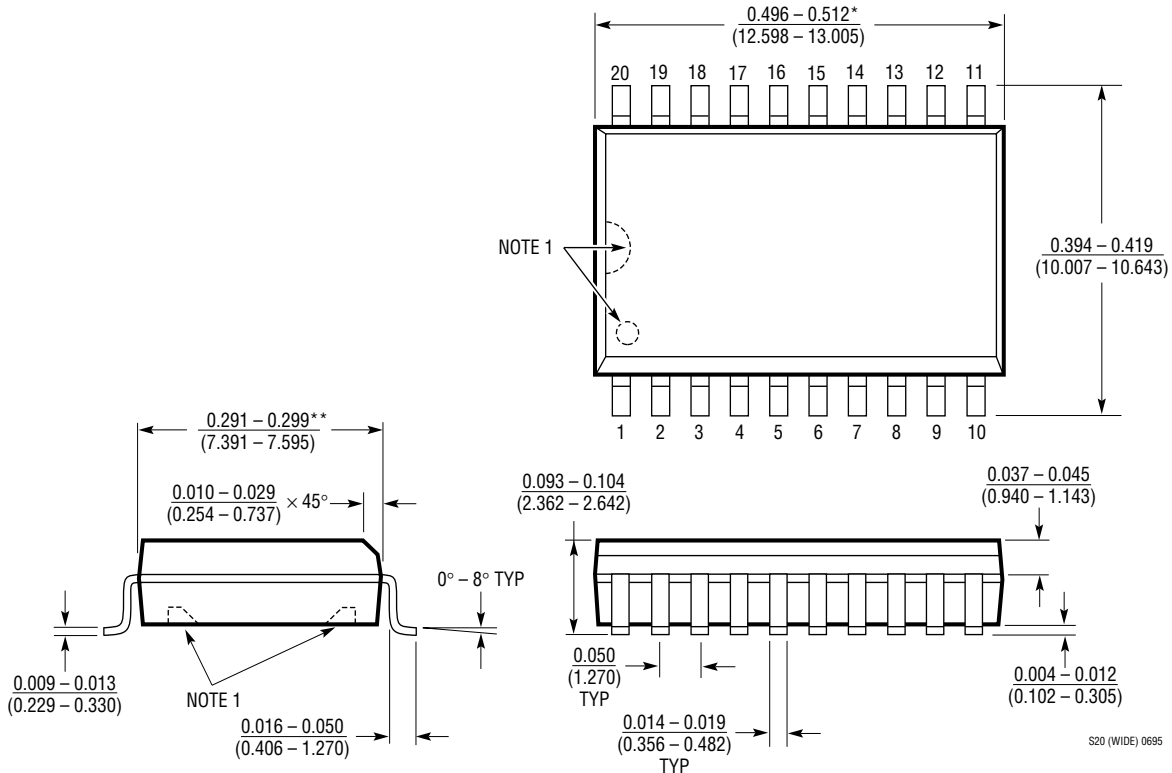

NOTE:
 1. PIN 1 IDENT, NOTCH ON TOP AND CAVITIES ON THE BOTTOM OF PACKAGES ARE THE MANUFACTURING OPTIONS. THE PART MAY BE SUPPLIED WITH OR WITHOUT ANY OF THE OPTIONS.
 *DIMENSION DOES NOT INCLUDE MOLD FLASH. MOLD FLASH SHALL NOT EXCEED 0.006" (0.152mm) PER SIDE
 **DIMENSION DOES NOT INCLUDE INTERLEAD FLASH. INTERLEAD FLASH SHALL NOT EXCEED 0.010" (0.254mm) PER SIDE

RELATED PARTS

PART NUMBER	DESCRIPTION	COMMENTS
LT1084	5A Low Dropout Linear Regulator	Good for Post Regulation of Switching Power Supplies
LT1105	Simplified Off-Line Controller	Solution for Universal Off-Line Inputs with Output to 100W
LT1241-5	High Frequency Current Mode PWM Controller	Operates at Oscillator Frequencies up to 500kHz
LT1247	High Frequency Current Mode PWM Controller	Operates at Oscillator Frequencies up to 1MHz
LT1248	Full-Feature Average Current Mode Power Factor Controller	Provides All Features in 16-Lead Package
LT1249	Minimal Parts Count Power Factor Controller	Simplified PFC Design
LTC®1509	Power Factor and PWM Controller	Complete Solution for Universal Off-Line Switching Power Supplies