

3161

HALL-EFFECT SWITCH FOR 2-WIRE APPLICATIONS

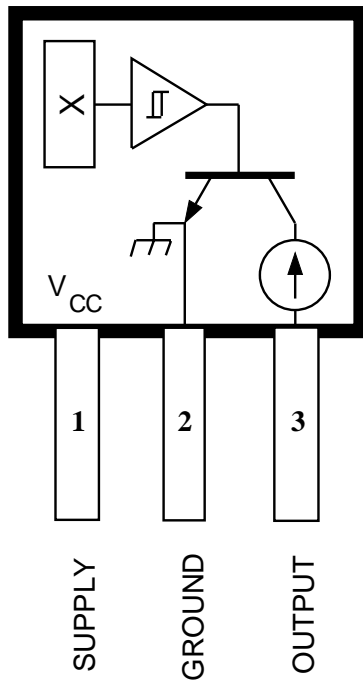

Dwg. PH-003-3

Pinning is shown viewed from branded side.

ABSOLUTE MAXIMUM RATINGS at $T_A = +25^\circ\text{C}$

Supply Voltage, V_{CC}	
Continuous	28 V
Surge ($t_w \leq 100$ ms)	40 V
Reverse Battery Voltage, V_{RCC}	
Continuous	-25 V
Surge ($t_w \leq 100$ ms)	-40 V
Magnetic Flux Density, B	Unlimited
Output OFF Voltage, V_{OUT}	28 V
Operating Temperature Range,	
T_A	-40°C to +85°C
Storage Temperature Range,	
T_S	-65°C to +170°C

This Hall-effect switch is a monolithic integrated circuit designed to operate continuously over extended temperatures to +85°C. The unipolar switching characteristic makes this device ideal for use with a simple bar or rod magnet. The A3161ELT and A3161EUA are identical except for package.

Each device includes a voltage regulator for operation with supply voltages of 3.5 to 25 volts, reverse battery protection diode, quadratic Hall-voltage generator, temperature compensation circuitry, small-signal amplifier, Schmitt trigger, and a constant-current open-collector output. Noise radiation is limited by control of the output current slew rate.

Two package styles provide a magnetically optimized package for most applications. Suffix 'LT' is a miniature SOT-89/TO-243AA transistor package for surface-mount applications; suffix 'UA' is a three-lead ultra-mini SIP for through-hole mounting.

FEATURES and BENEFITS

- Internal Current Regulator for 2-Wire Operation
- Output Slew Rate Controlled
- 3.5 V to 25 V Operation ... Needs Only An Unregulated Supply
- Reverse Battery Protection
- Excellent Temp. Stability
- Activate with Small, Commercially Available Permanent Magnets
- Small Size
- Solid-State Reliability ... No Moving Parts
- Resistant to Physical Stress

Always order by complete part number, e.g., **A3161ELT**.

3161

HALL-EFFECT SWITCH FOR 2-WIRE APPLICATIONS

ELECTRICAL CHARACTERISTICS over operating voltage and temperature ranges.

Characteristic	Symbol	Test Conditions	Limits			
			Min.	Typ.	Max.	Units
Supply Voltage	V_{CC}	Operating	3.5	—	25	V
Load Current (2-wire application)	$I_{OUT} + I_{CC}$	$3.5\text{ V} \leq V_{OUT} < 12\text{ V}, B < B_{RP}$	12	15	17	mA
		$V_{OUT} \geq 12\text{ V}, B < B_{RP}$	12	15	19	mA
		$B > B_{OP}$	—	3.5	5.0	mA
Output Current	I_{OUT}	$B < B_{RP}$	—	12	—	mA
	I_{OFF}	$V_{OUT} = 24\text{ V}, B > B_{OP}$	—	<1.0	10	μA
Output Saturation Voltage	V_{OUT}	$I_{OUT} = 5\text{ mA}, B < B_{RP}$	—	0.9	1.5	V
Output Slew Rate	di/dt	$C_L = 20\text{ pF}$	—	7.0	20	mA/ μs
Output Settling Time	t_{sd}	$C_L = 20\text{ pF}$	—	—	20	μs

MAGNETIC CHARACTERISTICS over operating supply voltage range.

Characteristic	Symbol	Limits						Units
		At $T_A = +25^\circ\text{C}$			Over Oper. Temp. Range			
		Min.	Typ.	Max.	Min.	Typ.	Max.	
Operate Point (output turns OFF)	B_{OP}	—	130	160	—	130	160	G
Release Point (output turns ON)	B_{RP}	30	110	—	30	110	—	G
Hysteresis ($B_{OP} - B_{RP}$)	B_{hys}	5.0	20	—	5.0	20	80	G

NOTE: Typical values are at $T_A = +25^\circ\text{C}$ and $V_{CC} = 12\text{ V}$.

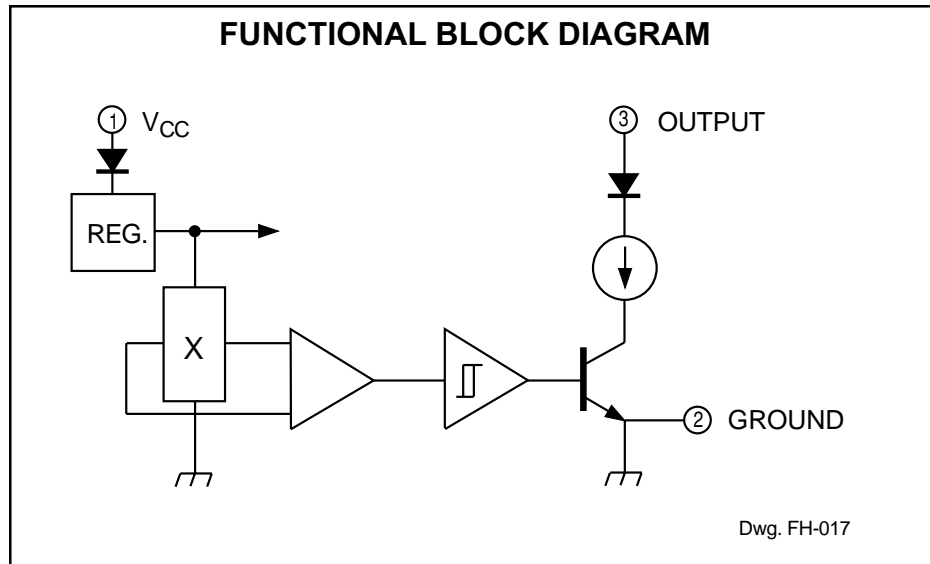

3161 HALL-EFFECT SWITCH FOR 2-WIRE APPLICATIONS

TYPICAL OPERATING CHARACTERISTICS

SWITCH POINTS

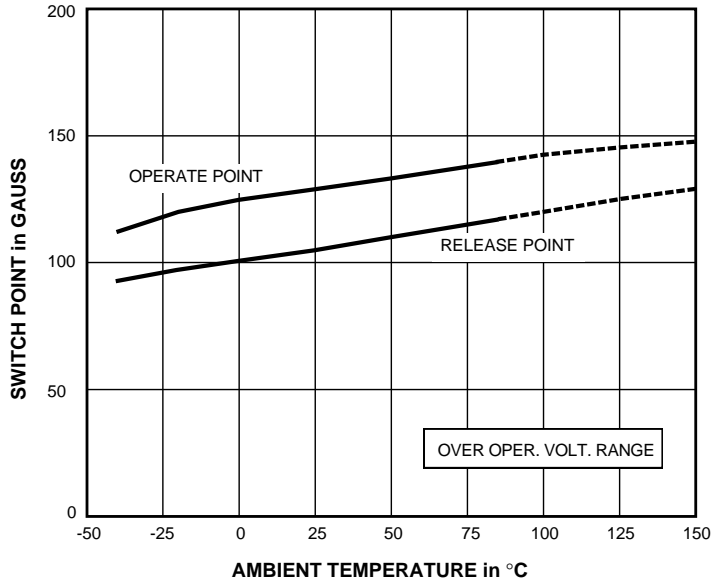

Dwg. GH-044-1

TOTAL SUPPLY CURRENT

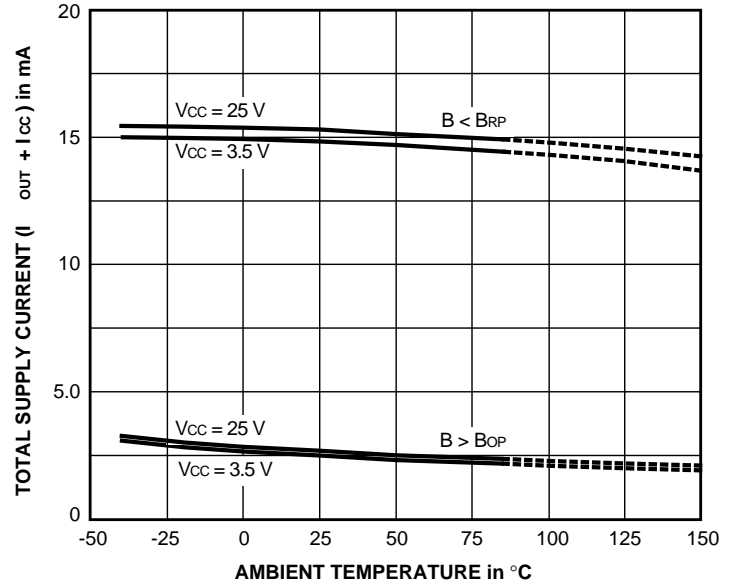

Dwg. GH-028-4

OUTPUT SATURATION VOLTAGE

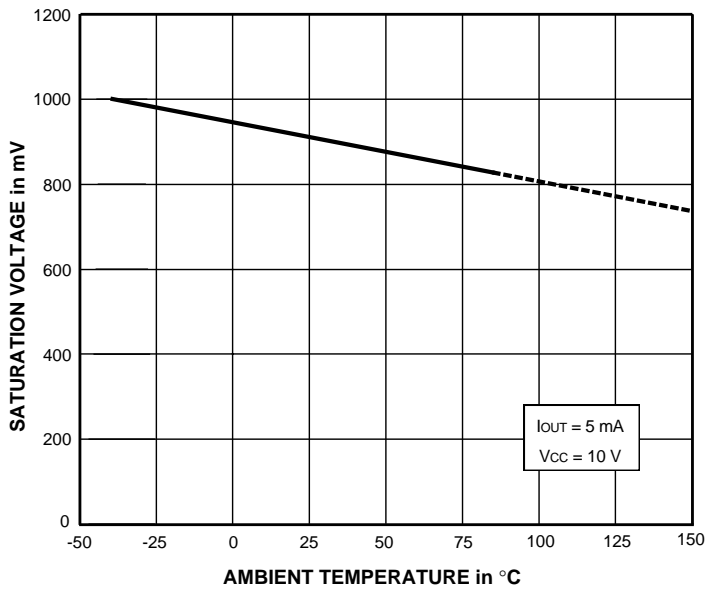

Dwg. GH-029-3

SAFE OPERATING AREA

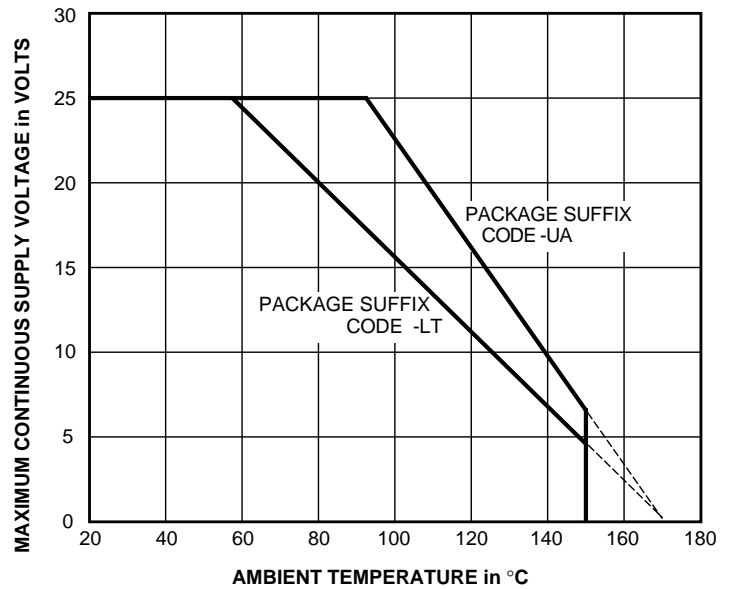

Dwg. GH-068

3161 HALL-EFFECT SWITCH FOR 2-WIRE APPLICATIONS

SENSOR LOCATIONS

Suffix "LT"

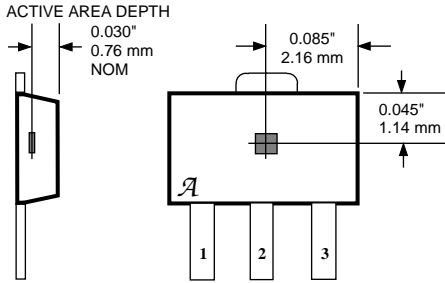

Dwg. MH-008-7

Suffix "UA"

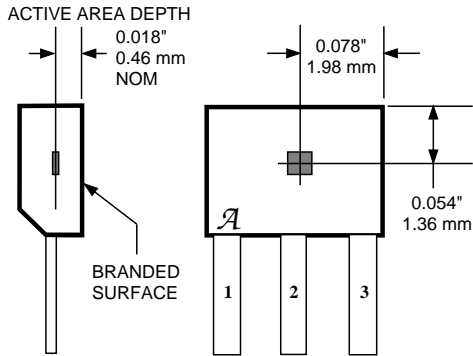

Dwg. MH-011-8

OPERATION

The output of these devices (pin 3) switches OFF when the magnetic field at the Hall sensor exceeds the operate point threshold (B_{OP}). When the magnetic field is reduced to below the release point threshold (B_{RP}), the device output switches ON. The difference in the magnetic operate and release points is called the hysteresis (B_{hys}) of the device. This built-in hysteresis allows clean switching of the output even in the presence of external mechanical vibration and electrical noise.

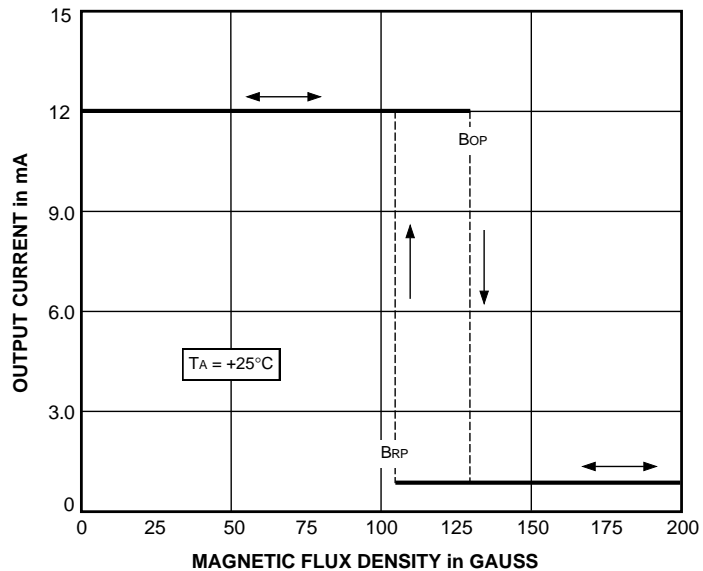

Dwg. GH-007-1

APPLICATIONS INFORMATION

These devices are normally operated in a 2-wire mode, where the supply terminal and the output terminal are tied together. An external comparator detects the change in total supply current by the addition (output ON, $B > B_{OP}$) or subtraction (output OFF, $B < B_{RP}$) of I_{OUT} .

Hall effect applications information is available in the "Hall-Effect IC Applications Guide", which can be found in the latest issue of the *Allegro MicroSystems Electronic Data Book*, AMS-702 or *Application Note 27701*, or at www.allegromicro.com.

TYPICAL 2-WIRE APPLICATION

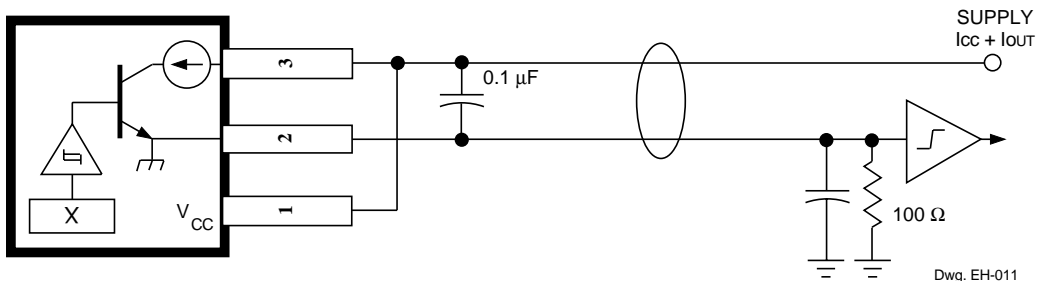

Dwg. EH-011

3161
HALL-EFFECT SWITCH
FOR 2-WIRE APPLICATIONS

PACKAGE DESIGNATOR 'LT'

Dimensions in Inches
(for reference only)

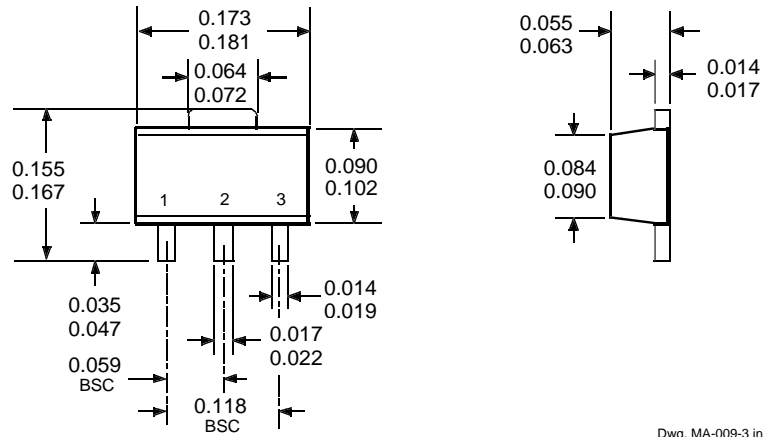

Dimensions in Millimeters
(controlling dimensions)

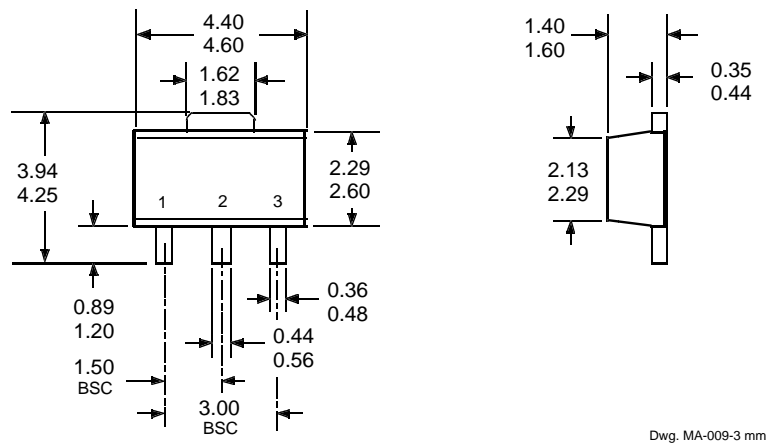

3161 HALL-EFFECT SWITCH FOR 2-WIRE APPLICATIONS

PACKAGE DESIGNATOR 'UA'

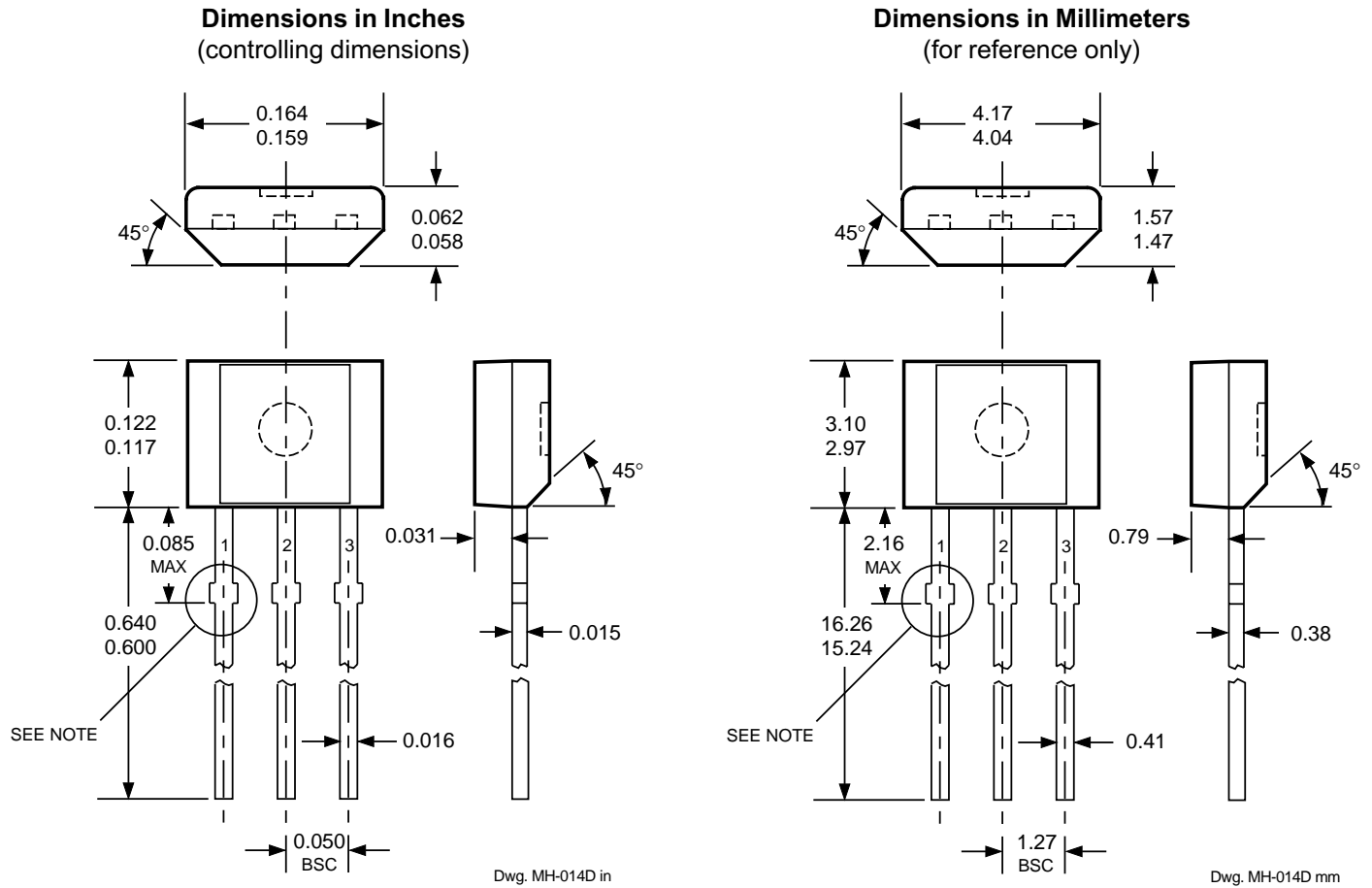

- NOTES: 1. Tolerances on package height and width represent allowable mold offsets. Dimensions given are measured at the widest point (parting line).
2. Exact body and lead configuration at vendor's option within limits shown.
3. Height does not include mold gate flash.

3161
HALL-EFFECT SWITCH
FOR 2-WIRE APPLICATIONS

Allegro MicroSystems, Inc. reserves the right to make, from time to time, such departures from the detail specifications as may be required to permit improvements in the design of its products.

The information included herein is believed to be accurate and reliable. However, Allegro MicroSystems, Inc. assumes no responsibility for its use; nor for any infringements of patents or other rights of third parties which may result from its use.

3161
HALL-EFFECT SWITCH
FOR 2-WIRE APPLICATIONS

HALL-EFFECT SENSORS SELECTION GUIDE

Partial Part Number	Avail. Oper. Temp.	Characteristics at T _A = +25°C			Features	Notes
		B _{OP} (max)	B _{RP} (min)	B _{hys} (typ)		
HALL-EFFECT UNIPOLAR SWITCHES in order of B_{Op} and B_{hys}						
3240	E/L	+50	+5.0	10	chopper stabilized	1
3210	E	±70	±5.0	7.7	micropower, chopper stabilized	
3361	E	+120	+50	5.0*	2-wire, chopper stabilized	
3362	E	+120	+50	5.0*	2-wire, chopper stabilized	
3161	E	+160	+30	20	2-wire	
3141	E/L	+160	+10	55		
3235	S	+175	+25	15*	output 1	2
		-25	-175	15*	output 2	2
5140	E	+200	+50	55	300 mA output	1, 3
3142	E/L	+230	+75	55		
3143	E/L	+340	+165	55		
3144	E/L	+350	+50	55		
3122	E/L	+400	+140	105		
3123	E/L	+440	+180	105		
3121	E/L	+450	+125	105		
3150	J	+40 to +850	-	20	programmable, chopper stabilized	1
HALL-EFFECT LATCHES & BIPOLAR SWITCHES[†] in order of B_{Op} and B_{hys}						
3260	E/L	+30	-30	20	bipolar, chopper stabilized	
3280	E/L	+40	-40	45	chopper stabilized	
3134	E/L	+50	-50	27	bipolar switch	
3133	K/L/S	+75	-75	52	bipolar switch	
3281	E/L	+90	-90	100	chopper stabilized	
3132	K/L/S	+95	-95	52	bipolar switch	
3187	E/L	+150	-150	100*		
3177	S	+150	-150	200		
3625	S	+150	-150	200	900 mA outputs	1, 3, 5
3626	S	+150	-150	200	400 mA outputs	1, 3, 5
3195	E/L	+160	-160	220		1, 4
3197	L	+160	-160	230		1
3175	S	+170	-170	200		
3188	E/L	+180	-180	200*		
3283	E/L	+180	-180	300	chopper stabilized	
3189	E/L	+230	-230	100*		
3275	S	+250	-250	100*		5
3185	E/L	+270	-270	340*		

Operating Temperature Ranges:

S = -20°C to +85°C, E = -40°C to +85°C, J = -40°C to +115°C, K = -40°C to +125°C, L = -40°C to +150°C

Notes 1. Protected.

2. Output 1 switches on south pole, output 2 switches on north pole for 2-phase, bifilar-wound, unipolar-driven brushless dc motor control.

3. Power driver output.

4. Active pull down.

5. Complementary outputs for 2-phase bifilar-wound, unipolar-driven brushless dc motor control.

* Minimum.

Latches will not switch on removal of magnetic field; bipolar switches may switch on removal of field but require field reversal for reliable operation over operating temperature range.

