

TENTATIVE TOSHIBA BIPOLAR LINEAR INTEGRATED CIRCUIT SILICON MONOLITHIC

TA1304F

TV-SOUND PROCESSOR

FEATURES

Sound processor

- 2 ch inputs (L-ch, R-ch)
- 3 ch outputs (L-ch, R-ch, W-ch)
- Volume, balance, treble, bass and woofer level control
- Built-in woofer low-pass filter
- Input matrix circuit
- ALS (Automatic Level Suppressor) circuit

I/O port circuit

- 2 ch input ports
- 2 ch output ports

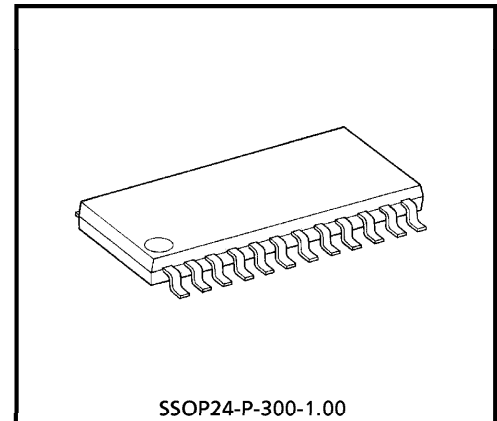

Weight : 0.33 g (Typ.)

980910EBA1

- TOSHIBA is continually working to improve the quality and the reliability of its products. Nevertheless, semiconductor devices in general can malfunction or fail due to their inherent electrical sensitivity and vulnerability to physical stress. It is the responsibility of the buyer, when utilizing TOSHIBA products, to observe standards of safety, and to avoid situations in which a malfunction or failure of a TOSHIBA product could cause loss of human life, bodily injury or damage to property. In developing your designs, please ensure that TOSHIBA products are used within specified operating ranges as set forth in the most recent products specifications. Also, please keep in mind the precautions and conditions set forth in the TOSHIBA Semiconductor Reliability Handbook.
- The products described in this document are subject to the foreign exchange and foreign trade laws.
- The information contained herein is presented only as a guide for the applications of our products. No responsibility is assumed by TOSHIBA CORPORATION for any infringements of intellectual property or other rights of the third parties which may result from its use. No license is granted by implication or otherwise under any intellectual property or other rights of TOSHIBA CORPORATION or others.
- The information contained herein is subject to change without notice.

BLOCK DIAGRAM

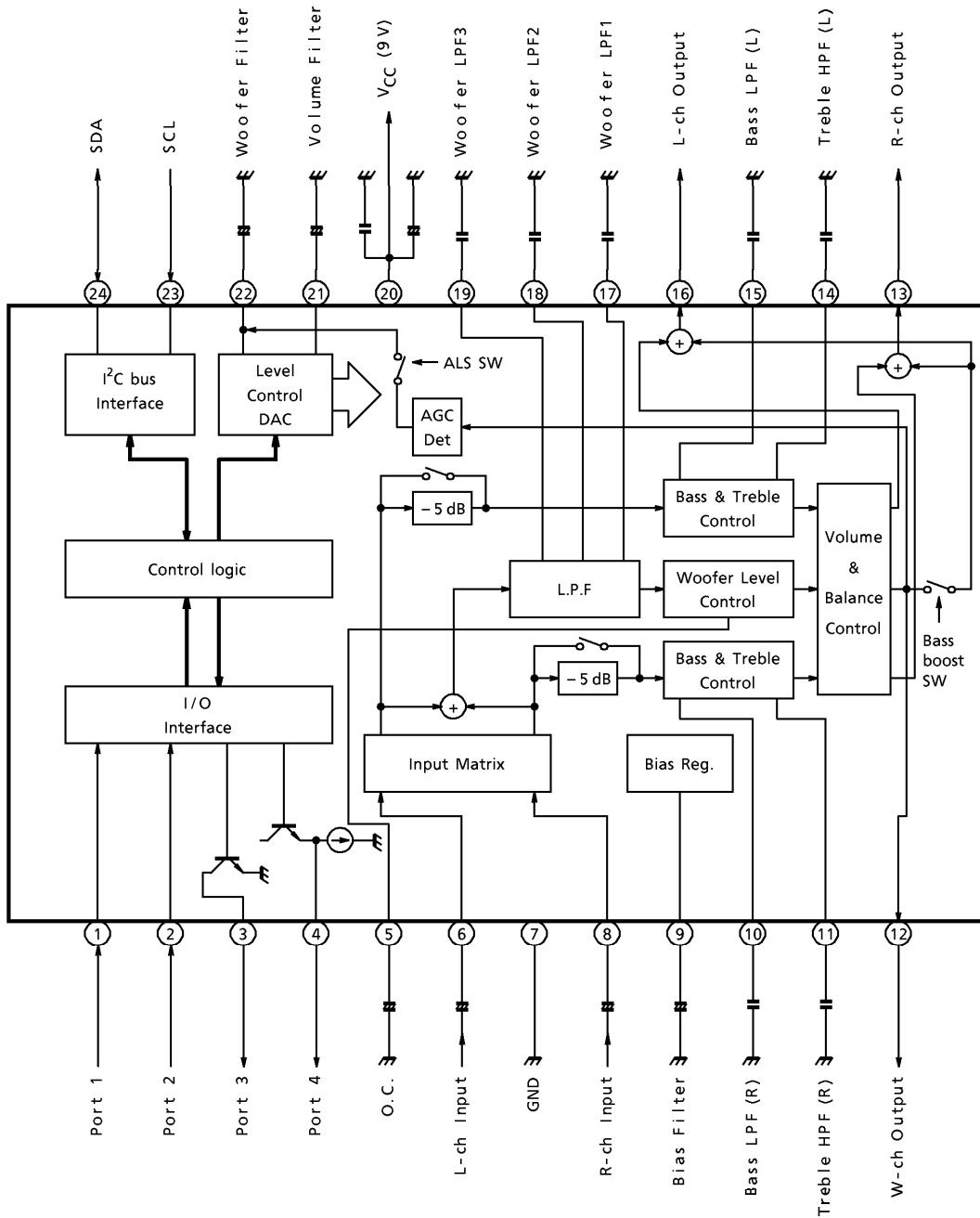

TERMINAL FUNCTION

PIN No.	NAME	FUNCTION	INTERFACE CIRCUIT
1 2	Port 1 Port 2	These are logical input terminals. Threshold voltage is 2.3 V. The input level of these terminals are read by MCU through I ² C bus lines.	
3	Port 3	A open collector type output controlled by MPU through I ² C bus lines. Maximum sink current is 1 mA.	
4	Port 4	A emitter follower type output controlled by MPU through I ² C bus lines. This terminal can 3 level output, 0 V, 2.5 V and 5 V. Maximum souce current is 2 mA, and maximum sink current is 250 μA.	
5	Offset cancelling filter	DC offset cancelling filter for Woofer channel. Connect a capacitor (10 μF) between this terminal and GND.	
6 8	L-ch input R-ch input	Audio input terminals.	

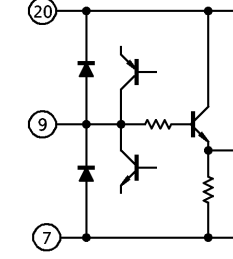
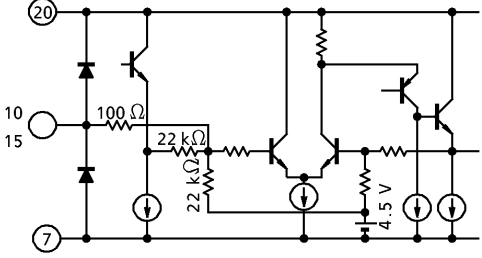
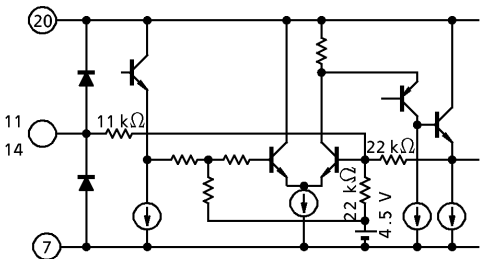
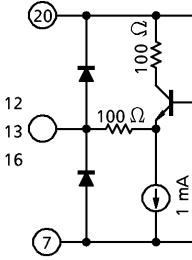
PIN No.	NAME	FUNCTION	INTERFACE CIRCUIT
7	GND	GND terminal.	—
9	Bias filter	Filter for noise rejection of the bias. Connect a capacitor (4.7 μ F) between this terminal and GND.	
10 15	Bass LPF (R) Bass LPF (L)	LPFs for bass control circuits. Connect capacitors (0.027 μ F) between each terminals and GND.	
11 14	Treble HPF (R) Treble HPF (L)	HPFs for bass control circuits. Connect capacitors (8200 pF) between each terminals and GND.	
13 12 16	W-ch output R-ch output L-ch output	Audio output terminals. Bass boost function, addition woofer channel signal to main channel signals, is available. Using ALS (Automatic Level Suppressor), it can reduce distortion in large signal input condition.	

PIN No.	NAME	FUNCTION	INTERFACE CIRCUIT
17 18 19	Woofer LPF 1 Woofer LPF 2 Woofer LPF 3	LPF for woofer. Connect a capacitor (0.033 μ F) between terminal 17 and GND. Connect a capacitor (0.047 μ F) terminal 18 and GND. Connect a capacitor (0.022 μ F) terminal 19 and GND.	
20	VCC	VCC terminal. Recommended operation voltage is 9 V \pm 10%.	—
21	Volume filter	Smoothing filter for volume control. Connect a capacitor (0.01 μ F) between this terminal and GND.	
22	Woofer level filter	Smoothing filter for volume control. Connect a capacitor (3.3 μ F) between this terminal and GND. This filter is also for ALS control.	
23	SCL	SCL terminal.	

PIN No.	NAME	FUNCTION	INTERFACE CIRCUIT
24	SDA	SDA terminal.	

I²C BUS CONTROL DATA TABLE

- Slave address : 80 (h) / Write mode
81 (h) / Read mode
- Write mode address map

SUB ADDRESS	MSB	b6	b5	b4	b3	b2	b1	LSB	DEFAULT DATA
00			Bass label (Effective data range : 0E (h)~72 (h))						40 (h) (Bass : Center)
01			Treble level (Effective data range : 0E (h)~72 (h))						40 (h) (Treble : Center)
02			Volume (Effective data range : 00 (h)~72 (h))						00 (h) (Volume : Min.)
03	TEST SW "0" : Normal "1" : Test	ALS SW "0" : Off "1" : On	ALS start point "00" : 150 mV "01" : 250 mV "10" : 350 mV "11" : 500 mV			Input att "0" : 0 dB "1" : -5 dB	Input matrix "00" : Normal "01" : R-ch "10" : L-ch "11" : Reverse		00 (h) (TEST SW : Normal ALS SW : Off ALS strat point : 150 mV input att : 0 dB Input matrix : Normal)
04			Woofer level (Effective data range : 00 (h)~72 (h))						00 (h) (Woofer level : min.)
05			Balance (Effective data range : 00 (h)~7F (h))						40 (h) (Balance : Center)
06			Port 4 "00" : 0.0 V "01" : 2.5 V "10" : 0.0 V "11" : 5.0 V	Port 3 "0" : On "1" : Off					20 (h) (Port3 : On Port4 : 0.0 V)
07	Bass boost SW "0" : On "1" : Off		Woofer LPF fo "00" : 100 Hz "01" : 125 Hz "10" : 170 Hz "11" : 210 Hz			Woofer LPF defeat "0" : Off "1" : On	Mute 2 "0" : Off "1" : On	Mute 1 "0" : Off "1" : On	10 (h) (Bass boost SW : Off Woofer LPF fo : 125 Hz Mute 1 : Off Mute 2 : Off)

The bits shown gray area must be "0".

- Read mode address map

MSB	b6	b5	b4	b3	b2	b1	LSB
P.O.R	1	1	1	1	1	Port 2	Port 1

No function bits (shown gray area) are always "1".

- P.O.R (Power on reset)
 - "0" : After read access
 - "1" : Power on reset
- Port1, 2
 - "0" : "High"
 - "1" : "Low"

Purchase of TOSHIBA I²C components conveys a license under the Philips I²C Patent Rights to use these components in an I²C system, provided that the system conforms to the I²C Standard Specification as define by Philips.

EXPLANATION OF THE FUNCTIONS. (Note : (h) means hexadecimal data, (b) means binary data)

- Bass level (Sub address 00 (h))

Bass level control. Cross-over frequency is 1 kHz.

Effective control data range is 0E (h)~72 (h) (100steps). Set this data to 0E (h), bass level goes to minimum level, and set this data to 72 (h), bass level goes to maximum level. Set this data to 40 (h), bass level goes to center level.

Switch on default data is 40 (h).

Control range is ± 12 dB (typ.).

- Treble level (Sub address 01 (h))

Treble level control. Cross-over frequency is 1 kHz.

Effective control data range is 0E (h)~72 (h) (100steps). Set this data to 0E (h), treble level goes to minimum level, and set this data to 72 (h), treble level goes to maximum level. Set this data to 40 (h), treble level goes to center level.

Switch on default data is 40 (h).

Control range is ± 12 dB (typ.).

- Volume control (Sub address 02 (h))

Volume control of L-ch, R-ch, and W-ch outputs.

Effective control data range is 00 (h)~72 (h)

Switch on default data is 00 (h).

- Woofer level control (Sub address 04 (h))

Volume control of only W-ch output.

Effective control data range is 00 (h)~72 (h)

Switch on default data is 00 (h).

- Balance control (Sub address 05 (h))

Balance control. Set this data to 40 (h), balance goes to center.

Effective control data range is 00 (h)~7F (h).

Switch on default data is 40 (h).

- Input matrix control (Sub address 03 (h) / b1~b0)

Output signal selection control.

Set these bits to 00 (b), output mode goes to normal mode (input signal of terminal 6 is outputted to terminal 16, and input signal of terminal 8 is outputted to terminal 13). Set these bits to 01 (b) output mode goes to R-ch mode (input signal of terminal 8 is outputted to terminal 13 and terminal 16). Set these bits to 10 (b) output mode goes to L-ch mode (input signal of terminal 6 is outputted to terminal 13 and terminal 16). Set these bits to 11 (b), output mode goes to reverse mode (input signal of terminal 6 is outputted to terminal 13, and input signal of terminal 8 is outputted to terminal 16).

Switch on default data is 00 (b).

- Input attenuation control (Sub address 03 (h) / b2)

When this function is active, Input signals are -5 dB attenuated at input stage of L-ch and R-ch. W-ch signal isn't attenuated. So, W-ch output level is up to 8 dB from L-ch and R-ch outputs relatively. Set the bit to 0 (b), attenuation is inactive, set the bit to 1 (b), attenuation is active. Switch on default data is 0 (b).

- ALS switch (Sub address 03 (h) / b6), ALS start point (Sub address 03 (h) / b5~b4)

When bass boost function (addition woofer ch signal to main ch signals) is active, output signals are distort when the signals are over the dynamic range of the circuits. ALS (Automatic Level Suppressor) suppresses W-ch signal level under ALS start point, reduces the distortion in large signals input condition.

Set the bit (Sub address 03 (h) / b6) to 0 (b), ALS is inactive. Set the bit to 1 (b), ALS is active. Switch on default data is 0 (b).

The bits of 03 (h) / b5~b4 set ALS start point. Set the bits to 00 (b), ALS start point is 150 mV_{rms}. Set the bits to 01 (b), ALS start point is 250 mV_{rms}. Set the bits to 10 (b), ALS start point is 350 mV_{rms}. And set the bits to 11 (b), ALS start point is 500 mV_{rms}. Switch on default data is 00 (b).

- Test switch (Sub address 03 (h) / b7)

This bit is for IC testing. So this bit must be set to 0 (b). Switch on default data is 0 (b).

- Port 3 control (Sub address 06 (h) / b3), Port 4 control (Sub address 06 (h) / b5~b4)

The IC, e.g. sound demultiplexer, which isn't available I²C Bus, can be controlled by I²C Bus through TA1304F.

Port 3 is open-collector type output. Set the bit to 0 (b), port3 is on. Set the bit to 1 (b), port3 is off.

Switch on default data 0 (b).

Port 4 is emitter-follower type output. It can output 3 levels. Set the bits to 00 (b) or 10 (b), port 4 outputs 0 V. Set to 01 (b), port 4 outputs 2.5 V. Set to 11 (b), port 4 outputs 5 V.

Switch on default data is 00 (h).

- Mute 1 (Sub address 07 (h) / b0), Mute 2 (Sub address 07 (h) / b1)

When Mute 1 is active, all outputs are muted. Set the bit to 0 (b), Mute 1 is inactive. Set the bit to 1 (b), Mute 1 is active.

Switch on default data is 0 (b).

When Mute 2 is active, only W-ch output is muted. Set the bit to 0 (b), Mute 2 is inactive. Set the bit to 1 (b), Mute 2 is active.

Switch on default data is 0 (b).

- Woofer LPF fo (Sub address 07 (h) / b5~b4)

These bits set cut off frequency (fo) of the low pass filter for W-ch.

Set the bits to 00 (b), fo is 100 Hz (-3 dB point). Set the bits to 01 (b), fo is 125 Hz. Set the bits to 10 (b), fo is 170 Hz. Set the bits to 11 (b), fo is 210 Hz.

Switch on default data is 01 (h).

- Woofer LPF defeat (Sub address 07 (h) / b3)

Set the bit to 1 (b), Woofer LPF is defeated.

This function is for IC testing. so, this bit must be set to 0 (b).

Switch on default data is 0 (b).

- Bass boost switch (Sub address 07 (h) / b7)

Bass boost function is adding W-ch signal to main channel signals. It can boost low frequency signal without woofer output.

Set the bit to 0 (b), Bass boost is inactive. Set the bit to 1 (b), bass boost is active.

Switch on default data is 0 (b).

MAXIMUM RATINGS (Ta = 25°C)

CHARACTERISTIC	SYMBOL	RATING	UNIT
Supply Voltage	V _{CC}	12	V
Power Dissipation	P _D	833 (Note)	mW
Operating Temperature	T _{opr}	-20~75	°C
Storage Temperature	T _{stg}	-55~150	°C
Maximum Input Voltage	V _{MAX}	V _{CC} + 0.3	V
Minimum Input voltage	V _{MIN}	GND - 0.3	V

(Note) : This value is on contion that the IC is mounted on PCB (50 mm x 50 mm). When using the device at Ta = 25°C, decrease the power dissipation by 6.7 mW for each increase of 1°C.

COMMENDED SUPPLY VOLTAGE

PIN No.	PIN NAME	MIN.	TYP.	MAX.	UNIT
20	V _{CC}	8.1	9.0	9.9	V

ELECTRICAL CHARACTERISTICS

DC current characteristics (V_{CC} = 9.0 V, Ta = 25°C)

PIN No.	PIN NAME	SYMBOL	MIN.	TYP.	MAX.	UNIT
20	V _{CC}	I _{CC}	22	34	45	mA

DC voltage characteristics (V_{CC} = 9.0 V, Ta = 25°C)

PIN No.	SYMBOL	TEST CIR-CUIT	TEST CONDITION	MIN.	TYP.	MAX.	UNIT
3	V ₃	—	In power on defalt	—	—	0.5	V
4	V ₄	—		—	—	0.5	
5	V ₅	—		4.0	4.5	5.0	
6	V ₆	—		4.0	4.5	5.0	
8	V ₈	—		4.0	4.5	5.0	
9	V ₉	—		5.2	5.7	6.2	
10	V ₁₀	—		4.0	4.5	5.0	
11	V ₁₁	—		4.0	4.5	5.0	
12	V ₁₂	—		4.0	4.5	5.0	
13	V ₁₃	—		4.0	4.5	5.0	
14	V ₁₄	—		4.0	4.5	5.0	
15	V ₁₅	—		4.0	4.5	5.0	
16	V ₁₆	—		4.0	4.5	5.0	
17	V ₁₇	—		4.6	5.1	5.6	
18	V ₁₈	—		4.6	5.1	5.6	
19	V ₁₉	—		4.6	5.1	5.6	
21	V ₂₁	—		—	0.0	—	
22	V ₂₂	—		0.5	1.5	2.0	

AC CHARACTERISTICS ($V_{CC} = 9.0\text{ V}$, $T_a = 25^\circ\text{C}$)

CHARACTERISTIC	SYMBOL	TEST CIRCUIT	TEST CONDITION	MIN.	TYP.	MAX.	UNIT
Gain	Go L	—	(Note 1)	0.0	2.0	4.0	dB
	Go R	—					
	GoAtt L	—		-7.0	-5.0	-3.0	
	GoAtt R	—					
	GoBst L	—		11.0	13.0	15.0	
	GoBst R	—					
	Go W	—		16.0	19.0	22.0	
THD	THD L	—	(Note 2)	—	0.03	1.0	%
	THD R	—			0.2		
	THD W	—					
S/N	SN L	—	(Note 3)	70	—	—	dB
	SN R	—					
	SN W	—		68			
Residual Noise	V _{NO} L	—	(Note 4)	—	—	50	μV_{rms}
	V _{NO} R	—					
	V _{NO} W	—					
Frequency Response (100 Hz)	Go100 L	—	(Note 5)	-2.0	0.0	2.0	dB
	Go100 R	—					
Frequency Response (10 kHz)	Go10k L	—	(Note 6)	-2.0	0.0	2.0	dB
	Go10k R	—					
LPF Frequency Response	G _{LPF100}	—	(Note 7)	4.0	6.0	8.0	dB
	G _{LPF125}	—		5.5	7.5	9.5	
	G _{LPF170}	—		4.0	6.0	8.0	
	G _{LPF210}	—		1.0	8.0	15.0	
Balance Center	ΔGLR	—	(Note 8)	-2.0	0.0	2.0	dB
Balance Minimum	G _{BLMIN} L	—	(Note 9)	—	—	-60	dB
	G _{BLMIN} R	—					
Bass Maximum	G _{BSMAX} L	—	(Note 10)	10	12	14	dB
	G _{BSMAX} R	—					
Bass Minimum	G _{BSMIN} L	—	(Note 11)	-14	-12	-10	dB
	G _{BSMIN} R	—					
Treble Maximum	G _{TRMAX} L	—	(Note 12)	10	12	14	dB
	G _{TRMAX} R	—					
Treble Minimum	G _{TRMIN} L	—	(Note 13)	-14	-12	-10	dB
	G _{TRMIN} R	—					
Volume Center	G _{VLCNT} L	—	(Note 14)	-17	-15	-12	dB
	G _{VLCNT} R	—					
	G _{VLCNT} W	—					
Volume Minimum	G _{VLMIN} L	—	(Note 15)	—	—	-65	dB
	G _{VLMIN} R	—					
	G _{VLMIN} W	—					
Woofer Level Center	G _{WLCNT}	—	(Note 16)	-9.5	-7.5	-5.5	dB

CHARACTERISTIC	SYMBOL	TEST CIRCUIT	TEST CONDITION	MIN.	TYP.	MAX.	UNIT
ALS Start Point 0	v ALS 0	—	(Note 17)	142	180	226	mV _{rms}
ALS Start Point 1	v ALS 1	—		246	310	391	
ALS Start Point 2	v ALS 2	—		341	430	541	
ALS Start Point 3	v ALS 3	—		500	630	794	
Cross Talk	CT L-R	—	(Note 18)	—	—	-75	dB
	CT R-L	—					
Ripple Rejection (Volume Minimum)	RR1 L	—	(Note 19)	—	—	-30	dB
	RR1 R	—					
	RR1 W	—					
Ripple Rejection (Volume Maximum)	RR2 L	—	(Note 20)	—	—	-30	dB
	RR2 R	—				-25	
	RR2 W	—					
Output Dynamic Range	vDOUT L	—	(Note 21)	6.0	6.7	—	V _{p-p}
	vDOUT R	—					
	vDOUT W	—					
Input Dynamic Range	vDIN L	—	(Note 22)	5.5	7.0	—	V _{p-p}
	vDIN R	—					
	vDIN W	—		3.0	4.2		
DC Offset	ΔVL	—	(Note 23)	—	—	±350	mV
	ΔVR	—					
	ΔVW	—					
Mute Redsisual Level	GMUT L	—	(Note 24)	—	—	-70	dB
	GMUT R	—					
	GMUT W	—					
Port 1, 2 Low-Level Voltage	VINL 1	—	(Note 25)	1.0	—	—	V
	VINL 2	—					
Port 1, 2 High-Level Voltage	VINH 1	—	(Note 26)	—	—	3.5	V
	VINH 2	—					
Port 3 Low-Level Voltage	V3LOW	—	(Note 27)	—	—	0.5	V
Port 4 Low-Level Voltage	V4LOW	—	(Note 28)	—	—	0.5	V
Port 4 Medium-Level Voltage	V4MID	—		2.0	2.5	3.0	V
Port 4 High-level Voltage	V4HI	—		4.5	5.0	5.5	V

TEST CONDITION

NOTE	INPUT POINT	MEAS. POINT	BUS DATA (HEXADECIMAL)								SW ₁	TEST METHOD
			00	01	02	03	04	05	06	07		
1	TP6 TP8	TP12 TP13 TP16	40	40	72	00 / 04	72	40	*	10 / 90	(a)	<ul style="list-style-type: none"> ● Set data of sub address 03 (h) to 00 (h) and set data of sub address 07 (h) to 10 (h). ● Input signal (1 kHz, 500 mV_{rms}, sine wave) to TP6 and TP8. ● Measure amplitude of TP13 and TP16 (v13₁ mV_{rms}, v16₁ mV_{rms}). ● Go R dB = 20 log (v13₁/500) Go L dB = 20 log (v16₁/500) ● Set data of sub address 03 (h) to 04 (h). ● Measure amplitude of TP13 and TP16 (v13₂ mV_{rms}, v16₂ mV_{rms}). ● GoAtt R dB = 20 log (v13₂/13₁) GoAtt L dB = 20 log (v16₂/16₁) ● Set data of sub address 03 (h) to 00 (h) and set data of sub address 07 (h) to 10 (h). ● Input signal (80 Hz, 125 mV_{rms}, sine wave) to TP6 and TP8 ● Measure amplitude of TP13 and TP16 (v13₃ mV_{rms}, v16₃ mV_{rms}). ● Set data of sub address 07 (h) to 90 (h). ● Measure amplitude of TP13 and TP16 (v13₄ mV_{rms}, v16₄ mV_{rms}). ● GoBst R dB = 20 log (v13₄/13₃) GoBst L dB = 20 log (v16₄/16₃) ● Measure amplitude of TP12 (v12 mV_{rms}). ● Go W dB = 20 log (v12/125)
2	↑	↑	↑	↑	↑	00	↑	↑	*	10	↑	<ul style="list-style-type: none"> ● Input signal (1 kHz, 500 mV_{rms}, sine wave) to TP6 and TP8 ● Measure THD of TP13 and TP16 (THD R %, THD L %). ● Input signal (80 Hz, 125 mV_{rms}, sine wave) to TP6 and TP8. ● Measure THD of TP12 (THD W %).

* : Don't care

NOTE	INPUT POINT	MEAS. POINT	BUS DATA (HEXADECIMAL)								SW ₁	TEST METHOD
			00	01	02	03	04	05	06	07		
3	TP6 TP8	TP12 TP13 TP16	40	40	72	00	72	40	*	10	(a)	<ul style="list-style-type: none"> ● Input signal (1 kHz, 500 mV_{rms}, sine wave) to TP6 and TP8 ● Measure amplitude of TP13 and TP16 (v13s mV_{rms}, v16s mV_{rms}). ● Connect TP6 and TP8 to GND. ● Measure amplitude of TP13 and TP16 (v13n mV_{rms}, v16n mV_{rms}). ● SN R dB = 20 log (v13_s/v13_n) SN L dB = 20 log (v16_s/v16_n) ● Input signal (80 Hz, 125 mV_{rms}, sine wave) to TP6 and TP8. ● Measure amplitude of TP12 (v12_s mV_{rms}). ● Connect TP6 and TP8 to GND. ● Measure amplitude of TP12 (v12_n mV_{rms}). ● SN W dB = 20 log (v12_s/v12_n)
4	—	↑	↑	↑	00	↑	00	↑	*	↑	↑	<ul style="list-style-type: none"> ● Connect TP6 and TP8 to GND. ● Measure amplitude of TP12, TP13 and TP16 (vNO W μV_{rms}, vNO R μV_{rms}, vNO L μV_{rms}).
5	TP6 TP8	TP12 TP13	↑	↑	72	↑	72	↑	*	↑	↑	<ul style="list-style-type: none"> ● Input signal (1 kHz, 500 mV_{rms}, sine wave) to TP6 and TP8. ● Measure amplitude of TP13 and TP16 (v13_O mV_{rms}, v16_O mV_{rms}). ● Input signal (100 Hz, 500 mV_{rms}, sine wave) to TP6 and TP8. ● Measure amplitude of TP13 and TP16 (v13 mV_{rms}, v16 mV_{rms}). ● Go100 R dB = 20 log (v13/v13_O) Go100 L dB = 20 log (v16/v16_O)
6	↑	↑	↑	↑	↑	↑	↑	↑	*	↑	↑	<ul style="list-style-type: none"> ● Input signal (1 kHz, 500 mV_{rms}, sine wave) to TP6 and TP8. ● Measure amplitude of TP13 and TP16 (v13_O mV_{rms}, v16_O mV_{rms}). ● Input signal (10 kHz, 500 mV_{rms}, sine wave) to TP6 and TP8. ● Measure amplitude of TP13 and TP16 (v13 mV_{rms}, v16 mV_{rms}). ● Go10k R dB = 20 log (v13/v13_O) Go10k L dB = 20 log (v16/v16_O)

* : Don't care

NOTE	INPUT POINT	MEAS. POINT	BUS DATA (HEXADECIMAL)								SW ₁	TEST METHOD
			00	01	02	03	04	05	06	07		
7	TP6 TP8	TP12	40	40	72	00	72	40	*	00 / 10 / 20 / 30 / 14	(a)	<ul style="list-style-type: none"> ● Input signal (300 Hz, 125 mV_{rms}, sine wave) to TP6 and TP8. ● Set data of sub address 07 (h) to 00 (h). ● Measure amplitude of TP12 (v12₀ mV_{rms}). ● Set data of sub address 07 (h) to 10 (h). ● Measure amplitude of TP12 (v12₁ mV_{rms}). ● Set data of sub address 07 (h) to 20 (h). ● Measure amplitude of TP12 (v12₂ mV_{rms}). ● Set data of sub address 07 (h) to 30 (h). ● Measure amplitude of TP12 (v12₃ mV_{rms}). ● Set data of sub address 07 (h) to 14 (h). ● Measure amplitude of TP12 (v12_x mV_{rms}). ● G_{LPF}80 dB = 20 log (v12₀/v12₁) G_{LPF}100 dB = 20 log (v12₁/v12₂) G_{LPF}130 dB = 20 log (v12₂/v12₃) G_{LPF}160 dB = 20 log (v12₃/v12_x)
8	↑	TP13 TP16	↑	↑	↑	↑	↑	↑	*	10	↑	<ul style="list-style-type: none"> ● Input signal (1 kHz, 500 mV_{rms}, sine wave) to TP6 and TP8. ● Measure amplitude of TP13 and TP16 (v13 mV_{rms}, v16 mV_{rms}). ● ΔG_{LR} dB = 20 log (v16/v13)

* : Don't care

NOTE	INPUT POINT	MEAS. POINT	BUS DATA (HEXADECIMAL)								SW ₁	TEST METHOD
			00	01	02	03	04	05	06	07		
9	TP6 TP8	TP13 TP16	40	40	72	00	72	0E / 72	*	10	(a)	<ul style="list-style-type: none"> ● Input signal (1 kHz, 500 mV_{rms}, sine wave) to TP6 and TP8. ● Set data of sub address 05 (h) to 0E (h). ● measure amplitude of TP13 and TP16 (v13_R mV_{rms}, v16_R mV_{rms}). ● Set data of sub address 05 (h) to 72 (h). ● Measure amplitude of TP13 and TP16 (v13_L mV_{rms}, v16_L mV_{rms}). ● GBLMIN R dB = 20 log (v13_R/v16_R) GBLMIN L dB = 20 log (v16_L/v13_L)
10	↑	↑	40 / 72	↑	↑	↑	↑	40	*	↑	↑	<ul style="list-style-type: none"> ● Input signal (100 Hz, 250 mV_{rms}, sine wave) to TP6 and TP8. ● Set data of sub address 00 (h) to 40 (h). ● Measure amplitude of TP13 and TP16 (v13_O mV_{rms}, v16_O mV_{rms}). ● Set data of sub address 00 (h) to 72 (h). ● Measure amplitude of TP13 and TP16 (v13_B mV_{rms}, v16_B mV_{rms}). ● GBSMAX R dB = 20 log (v13_B/v13_O) GBSMAX L dB = 20 log (v16_B/v16_O)
11	↑	↑	40 / 0E	↑	↑	↑	↑	↑	*	↑	↑	<ul style="list-style-type: none"> ● Input signal (100 Hz, 250 mV_{rms}, sine wave) to TP6 and TP8. ● Set data of sub address 00 (h) to 40 (h). ● Measure amplitude of TP13 and TP16 (v13_O mV_{rms}, v16_O mV_{rms}). ● Set data of sub address 00 (h) to 0E (h). ● Measure amplitude of TP13 and TP16 (v13_B mV_{rms}, v16_B mV_{rms}). ● GBSMIN R dB = 20 log (v13_B/v13_O) GBSMIN L dB = 20 log (v16_B/v16_O)

* : Don't care

NOTE	INPUT POINT	MEAS. POINT	BUS DATA (HEXADECIMAL)								SW ₁	TEST METHOD
			00	01	02	03	04	05	06	07		
12	TP6 TP8	TP13 TP16	40	40 / 27	72	00	72	40	*	10	(a)	<ul style="list-style-type: none"> ● Input signal (10 kHz, 250 mV_{rms}, sine wave) to TP6 and TP8. ● Set data of sub address 01 (h) to 40 (h). ● Measure amplitude of TP13 and TP16 (v13_O mV_{rms}, v16_O mV_{rms}). ● Set data of sub address 01 (h) to 72 (h). ● Measure amplitude of TP13 and TP16 (v13_T mV_{rms}, v16_T mV_{rms}). ● GTRMAX R dB = 20 log (v13_T/v13_O) GTRMAX L dB = 20 log (v16_T/v16_O)
13	↑	↑	↑	40 / 0E	↑	↑	↑	↑	*	↑	↑	<ul style="list-style-type: none"> ● Input signal (10 kHz, 250 mV_{rms}, sine wave) to TP6 and TP8. ● Set data of sub address 01 (h) to 40 (h). ● Measure amplitude of TP13 and TP16 (v13_O mV_{rms}, v16_O mV_{rms}). ● Set data of sub address 01 (h) to 0E (h). ● Measure amplitude of TP13 and TP16 (v13_T mV_{rms}, v16_T mV_{rms}). ● GTRMIN R dB = 20 log (v13_T/v13_O) GTRMIN L dB = 20 log (v16_T/v16_O)

* : Don't care

NOTE	INPUT POINT	MEAS. POINT	BUS DATA (HEXADECIMAL)								SW ₁	TEST METHOD
			00	01	02	03	04	05	06	07		
14	TP6 TP8	TP12 TP13 TP16	40	40	72 / 40	00	72	40	*	10	(a)	<ul style="list-style-type: none"> ● Input signal (1 kHz, 500 mV_{rms}, sine wave) to TP6 and TP8. ● Set data of sub address 02 (h) to 72 (h). ● Measure amplitude of TP13 and TP16 (v13_O mV_{rms}, v16_O mV_{rms}). ● Set data of sub address 02 (h) to 40 (h). ● measure amplitude of TP13 and TP16 (v13_C mV_{rms}, v16_C mV_{rms}). ● G_{VLCNT} R dB = 20 log (v13_C/v13_O) G_{VLCNT} L dB = 20 log (v16_C/v16_O) ● Input signal (80 Hz, 125 mV_{rms}, sine wave) to TP6 and TP8 ● Set data of sub address 02 (h) to 72 (h). ● Measure amplitude of TP12 (v12_O mV_{rms}). ● Set data of sub address 02 (h) to 40 (h). ● Measure amplitude of TP12 (v12_C mV_{rms}). ● G_{VLCNT} W dB = 20 log (v12_C/v12_O)

* : Don't care

NOTE	INPUT POINT	MEAS. POINT	BUS DATA (HEXADECIMAL)								SW ₁	TEST METHOD
			00	01	02	03	04	05	06	07		
15	TP6 TP8	TP12 TP13 TP16	40	40	72 / 0E	00	72	40	*	10	(a)	<ul style="list-style-type: none"> ● Input signal (1 kHz, 500 mV_{rms}, sine wave) to TP6 and TP8. ● Set data of sub address 02 (h) to 72 (h). ● Measure amplitude of TP13 and TP16 (v13_O mV_{rms}, v16_O mV_{rms}). ● Set data of sub address 02 (h) to 0E (h). ● measure amplitude of TP13 and TP16 (v13_{MIN} mV_{rms}, v16_{MIN} mV_{rms}). ● G_{VLMIN} R dB = 20 log (v13_{MIN} / v13_O) ● G_{VLMIN} L dB = 20 log (v16_{MIN} / v16_O) ● Input signal (80 Hz, 125 mV_{rms}, sine wave) to TP6 and TP8 ● Set data of sub address 02 (h) to 72 (h). ● Measure amplitude of TP12 (v12_O mV_{rms}). ● Set data of sub address 02 (h) to 0E (h). ● measure amplitude of TP12 (v12_{MIN} mV_{rms}). ● G_{VLMIN} W dB = 20 log (v12_{MIN} / v12_O)
16	↑	TP12	↑	↑	72	↑	72 / 40	↑	*	↑	↑	<ul style="list-style-type: none"> ● Input signal (80 Hz, 125 mV_{rms}, sine wave) to TP6 and TP8 ● Set data of sub address 04 (h) to 72 (h). ● Measure amplitude of TP12 (v12_O mV_{rms}). ● Set data of sub address 04 (h) to 40 (h). ● Measure amplitude of TP12 (v12_C mV_{rms}). ● G_{WLCNT} dB = 20 log (v12_C / v12_O)

* : Don't care

NOTE	INPUT POINT	MEAS. POINT	BUS DATA (HEXADECIMAL)								SW ₁	TEST METHOD
			00	01	02	03	04	05	06	07		
17	TP6 TP8	TP12	40	40	72	40 / 50 / 60 / 70	72	40	*	10	(a)	<ul style="list-style-type: none"> ● Input signal (80 Hz, 500 mV_{rms}, sine wave) to TP6 and TP8 ● Set data of sub address 03 (h) to C0 (h). ● Measure amplitude of TP12 (VALS 0 V_{p-p}). ● Set data of sub address 03 (h) to D0 (h). ● Measure amplitude of TP12 (VALS 1 V_{p-p}). ● Set data of sub address 03 (h) to E0 (h). ● Measure amplitude of TP12 (VALS 2 V_{p-p}). ● Set data of sub address 03 (h) to F0 (h). ● Measure amplitude of TP12 (VALS 3 V_{p-p}).
18	↑	TP13 TP16	↑	↑	↑	00	↑	↑	*	↑	↑	<ul style="list-style-type: none"> ● Connect TP8 to GND. ● Input signal (1 kHz, 500 mV_{rms}, sine wave) to TP6. ● Measure 1 kHz spectrum of TP16 output (vTP16 dB_μV). ● Measure 1 kHz spectrum of TP13 output (vTP13 dB_μV). ● CT_{L-R} dB = vTP16 – vTP13 ● Connect TP6 to GND. ● Input signal (1 kHz, 500 mV_{rms}, sine wave) to TP8. ● Measure 1 kHz spectrum of TP13 output (vTP13 dB_μV). ● Measure 1 kHz spectrum of TP16 output (vTP16 dB_μV). ● CT_{R-L} dB = vTP13 – vTP16
19	—	TP12 TP13 TP16	↑	↑	00	↑	00	↑	*	↑	(b)	<ul style="list-style-type: none"> ● Apply 9.0 V DC and sine wave (60 Hz, 500 mV_{rms}) to V_{CC} terminal. ● Measure amplitude of TP12, TP13 and TP16 (vTP12 mV_{rms}, vTP13 mV_{rms}, vTP16 mV_{rms}). ● RR1 W dB = 20 log (vTP12 / 500) ● RR1 R dB = 20 log (vTP13 / 500) ● RR1 L dB = 20 log (vTP16 / 500)

* : Don't care

NOTE	INPUT POINT	MEAS. POINT	BUS DATA (HEXADECIMAL)								SW ₁	TEST METHOD
			00	01	02	03	04	05	06	07		
20	—	TP12 TP13 TP16	40	40	72	00	72	40	*	10	(b)	<ul style="list-style-type: none"> Apply 9.0 V DC and sine wave (60 Hz, 500 mV_{rms}) to V_{CC} terminal. Measure amplitude of TP12, TP13 and TP16 (vTP12 mV_{rms}, vTP13 mV_{rms}, vTP16 mV_{rms}). RR1 W dB = 20 log (vTP12 / 500) RR1 R dB = 20 log (vTP13 / 500) RR1 L dB = 20 log (vTP16 / 500)
21	TP6 TP8	TP12 TP13 TP16	72	72	↑	↑	↑	↑	*	↑	(a)	<ul style="list-style-type: none"> Input signal (100 Hz, sine wave) to TP6 and TP8. Increase amplitude of the input signal, and measure THD of TP13 and TP16. Measure amplitude of TP13 and TP16 when THD of the output is 1% (vDOUT R1 V_{p-p}, vOUT L1 V_{p-p}). Input signal (10 kHz, sine wave) to TP6 and TP8. Increase amplitude of the input signal, and measure THD of TP13 and TP16. Measure amplitude of TP13 and TP16 when THD of the output is 1% (vDOUT R2 V_{p-p}, vDOUT L2 V_{p-p}). Smaller value vDOUT R1 or vDOUT R2 is vDOUT R. Smaller value vDOUT L1 or vDOUT L2 is vDOUT L. Input signal (80 Hz, sine wave) to TP6 and TP8. Increase amplitude of the input signal, and measure THD of TP12. Measure amplitude of TP12 when THD of the output is 1% (vDOUT W V_{p-p}).

* : Don't care

NOTE	INPUT POINT	MEAS. POINT	BUS DATA (HEXADECIMAL)								SW ₁	TEST METHOD
			00	01	02	03	04	05	06	07		
22	TP6 TP8	TP12 TP13 TP16	40	40	40	00	40	40	*	10	(a)	<ul style="list-style-type: none"> ● Input signal (1 kHz, sine wave) to TP6 and TP8. ● Increase amplitude of the input signal, and measure THD of TP13 and TP16. ● Measure amplitude of TP13 and TP16 when THD of the output is 1% ($v_{DIN R} V_{p-p}$, $v_{DIN L} V_{p-p}$). ● Input signal (80 Hz, sine wave) to TP6 and TP8. ● Increase amplitude of the input signal, and measure THD of TP13 and TP16. ● Measure amplitude of TP13 and TP16 when THD of the output is 1% ($v_{DIN W} V_{p-p}$).
23	—	↑	↑	↑	72	00 ~ 03	72	↑	*	00 / 01 / 02	↑	<ul style="list-style-type: none"> ● Connect TP6 and TP8 to GND. ● Change data of sub address 03 (h) to 00 (h)~03 (h). ● Change data of sub address 07 (h) to 00 (h), 01 (h) and 02 (h). ● Measure DC off set of TP12, TP13, TP16 ($\Delta V R$ mV, $\Delta V L$ mV, $\Delta V W$ mV).

* : Don't care

NOTE	INPUT POINT	MEAS. POINT	BUS DATA (HEXADECIMAL)								SW ₁	TEST METHOD
			00	01	02	03	04	05	06	07		
24	TP6 TP8	TP12 TP13 TP16	40	40	72	00	72	40	*	00 / 01 / 02	(a)	<ul style="list-style-type: none"> ● Input signal (1 kHz, 500 mV_{rms}, sine wave) to TP6 and TP8. ● Set data of sub address 07 (h) to 00 (h). ● Measure amplitude of TP13 and TP16 (v13_O mV_{rms}, v16_O mV_{rms}). ● Set data of sub address 07 (h) to 01 (h). ● Measure amplitude of TP13 and TP16 (v13_{MUT} mV_{rms}, v16_{MUT} mV_{rms}). ● GMUT R dB = 20 log (v13_{MUT} / v13_O) ● GMUT L dB = 20 log (v16_{MUT} / v16_O) ● Input signal (80 Hz, 125 mV_{rms}, sine wave) to TP6 and TP8. ● Set data of sub address 07 (h) to 00 (h). ● Measure amplitude of TP12 (v12_O mV_{rms}). ● Set data of sub address 07 (h) to 01 (h). ● Measure amplitude of TP12 (v12_{MUT} mV_{rms}). ● GMUT W dB = 20 log (v12_{MUT} / v12_O)
25	TP1 TP2	—	*	*	*	↑	*	*	*	*	↑	<ul style="list-style-type: none"> ● Apply 5 V to TP1 and TP2. ● Decrease voltage of TP1, and read IC status by I²C Bus. ● Measure voltage of TP1 when IC status is changed 00 (h) to 01 (h) (V_{INL} 1 V). ● Apply 5 V to TP1 and TP2. ● Decrease voltage of TP2, and read IC status by I²C Bus. ● Measure voltage of TP1 when IC status is changed 00 (h) to 02 (h) (V_{INL} 2 V).

* : Don't care

NOTE	INPUT POINT	MEAS. POINT	BUS DATA (HEXADECIMAL)								SW ₁	TEST METHOD
			00	01	02	03	04	05	06	07		
26	TP1 TP2	—	*	*	*	00	*	*	*	*	(a)	<ul style="list-style-type: none"> ● Apply 0 V to TP1 and apply 5 V to TP2. ● Increase voltage of TP1, and read IC status by I²C Bus. ● Measure voltage of TP1 when IC status is changed 01 (h) to 00 (h) (V_{INH} 1 V). ● Apply 5 V to TP1 and apply 0 V to TP2. ● Increase voltage of TP1, and read IC status by I²C Bus. ● Measure voltage of TP1 when IC status is changed 02 (h) to 00 (h) (V_{INH} 2 V).
27	—	TP3	*	*	*	*	*	*	04	*	↑	<ul style="list-style-type: none"> ● Measure voltage of TP3 (V_{3LOW} V).
28	—	TP4	*	*	*	00	*	*	00 / 10 / 30	*	↑	<ul style="list-style-type: none"> ● Set data of 06 (h) to 00 (h). ● Measure voltage of TP4 (V_{4LOW} V). ● Set data of 06 (h) to 10 (h). ● Measure voltage of TP4 (V_{4MID} V). ● Set data of 06 (h) to 30 (h). ● Measure voltage of TP4 (V_{4HI} V).

* : Don't care

DC TEST CIRCUIT

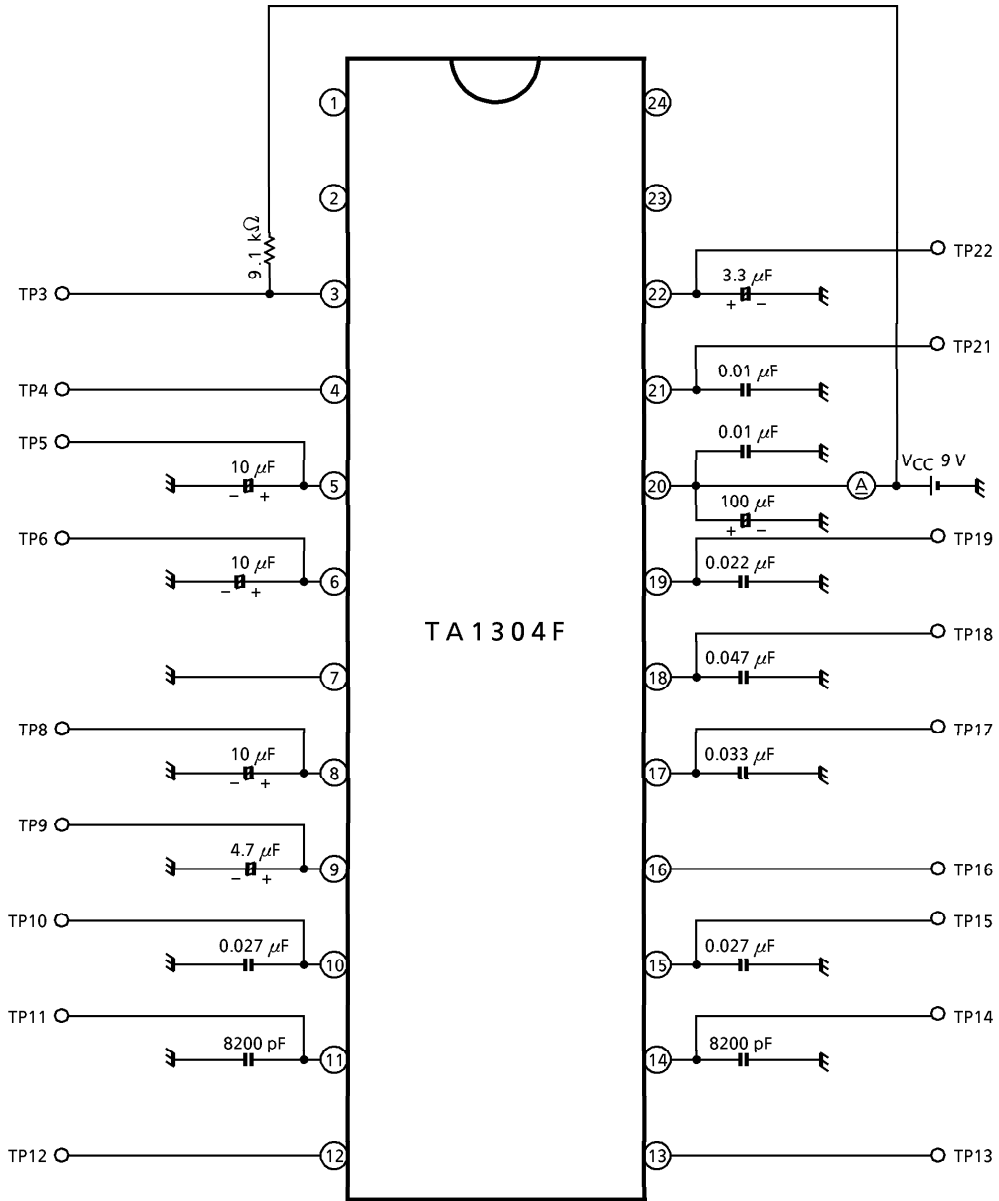

AC TEST CIRCUIT

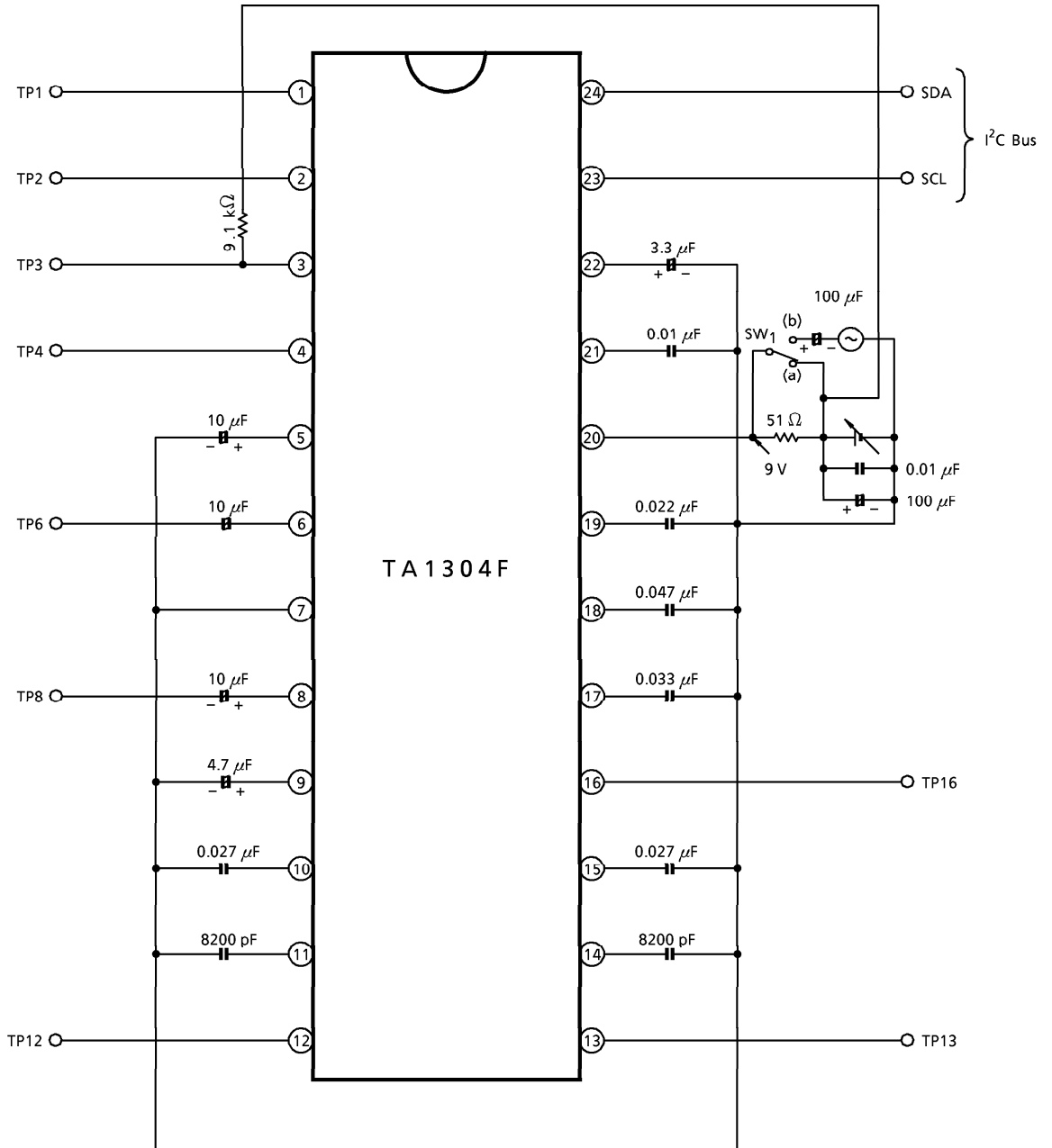

APPLICATION CIRCUIT

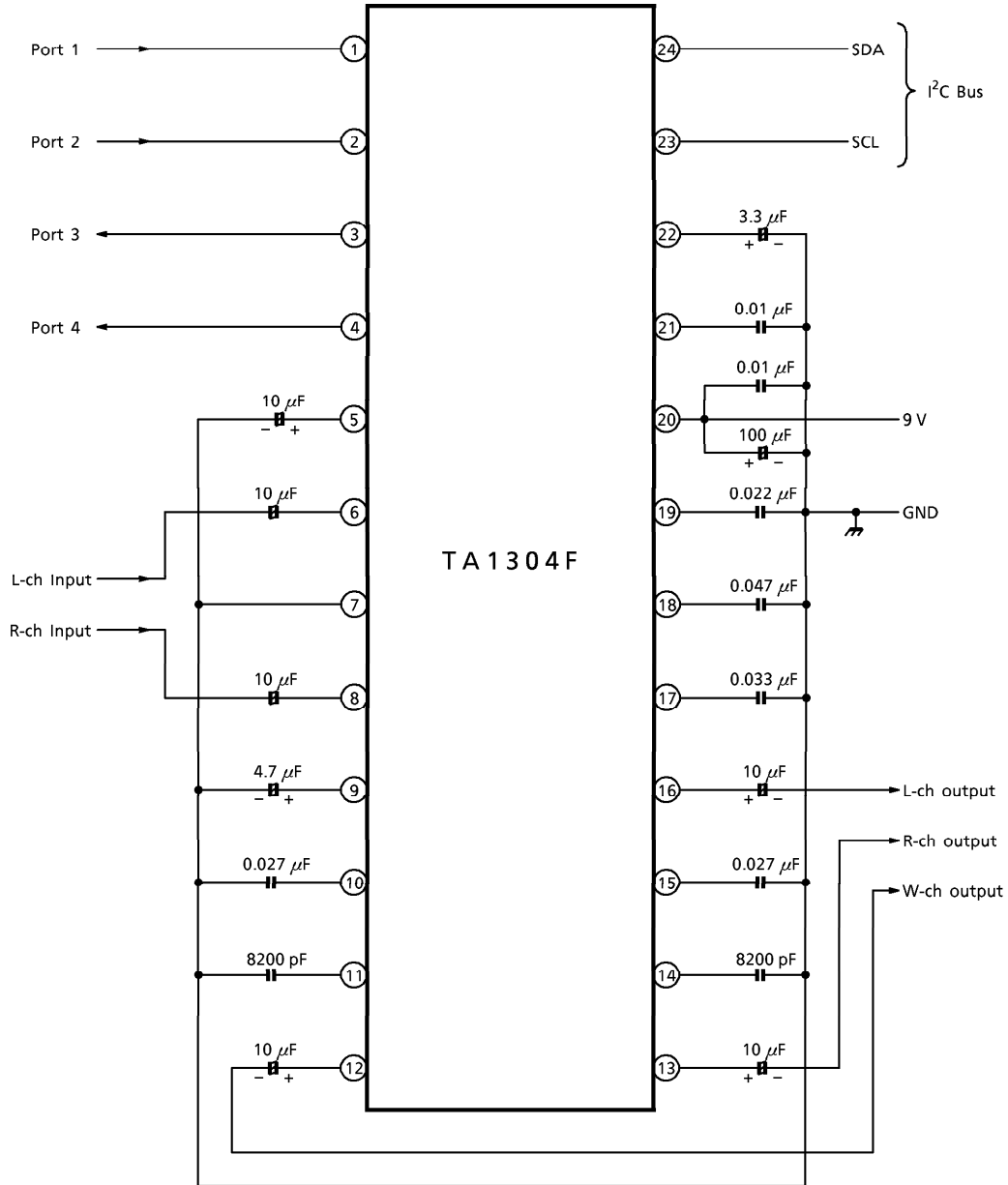

PACKAGE DIMENSIONS
SSOP24-P-300-1.00

Unit : mm

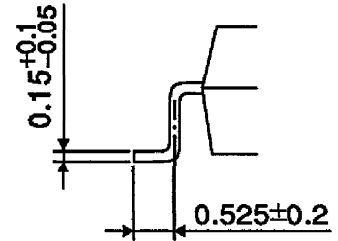
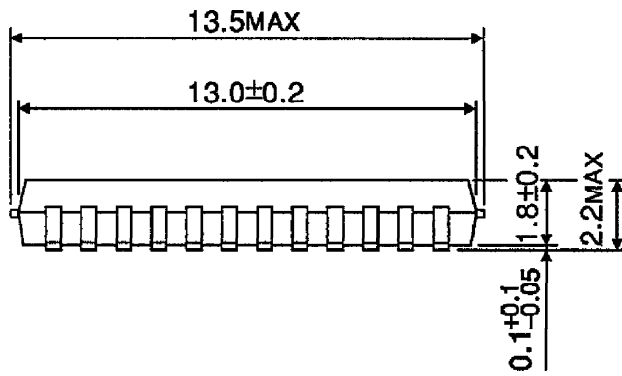
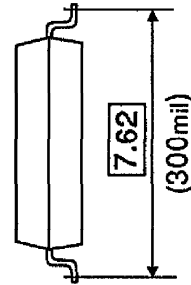
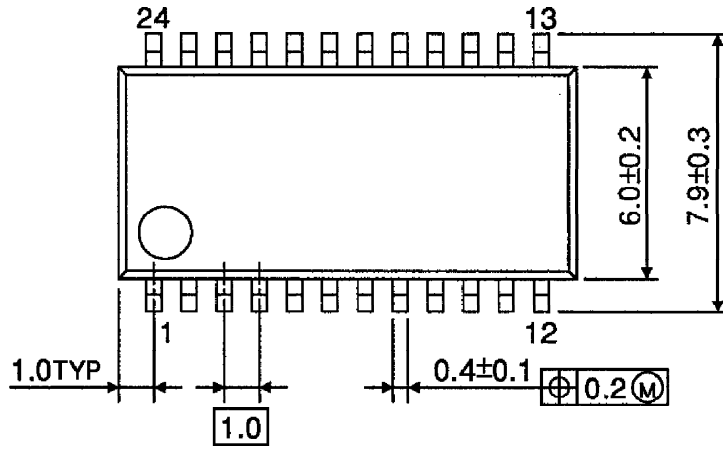

Weight : 0.33 g (Typ.)