

## Monolithic Integrated Feature Phone Circuit

### Description

The  $\mu$ -controlled telephone circuit U4090B is a linear integrated circuit for use in feature phones, answering machines and fax machines. It contains the speech circuit, tone ringer interface with DC/DC converter, sidetone equivalent and ear protection rectifiers. The circuit is line powered and contains all components necessary for amplification of signals and adaptation to the line.

An integrated voice switch with loudspeaker amplifier allows loudhearing or hands-free operation. With an anti-feedback function, acoustical feedback during loudhearing can be reduced significantly. The generated supply voltage is suitable for a wide range of peripheral circuits.

### Features

- DC characteristic adjustable
- Transmit and receive gain adjustable
- Symmetrical input of microphone amplifier
- Anti-clipping in transmit direction
- Automatic line-loss compensation
- Symmetrical output of earpiece amplifier
- Built-in ear protection
- DTMF and MUTE input
- Adjustable sidetone suppression independent of sending and receiving amplification
- Speech circuit with two sidetone networks
- Built-in line detection circuit
- Integrated amplifier for loudhearing operation
- Anti-clipping for loudspeaker amplifier
- Improved acoustical feedback suppression
- Power down
- Voice switch

- Tone ringer interface with dc/dc converter
- Zero crossing detection
- Common speaker for loudhearing and tone ringer
- Supply voltages for all functional blocks of a subscriber set
- Integrated transistor for short circuiting the line voltage
- Answering machine interface
- Operation possible from -10 mA line currents

### Benefits

- Savings of one piezo-electric transducer
- Complete system integration of analog signal processing on one chip
- Very few external components

### Applications

Feature phone, answering machine, fax machine, speaker phone

### Block Diagram

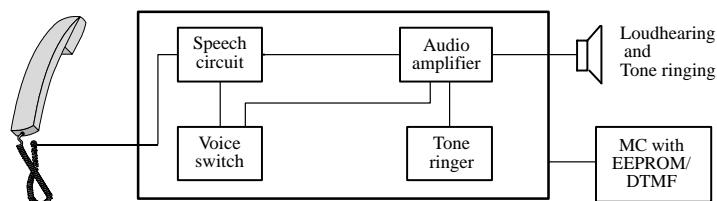

94 8741

### Ordering Information

Extended Type Number	Package	Remarks
U4090B-NFN	SSO44	

Detailed Block Diagram

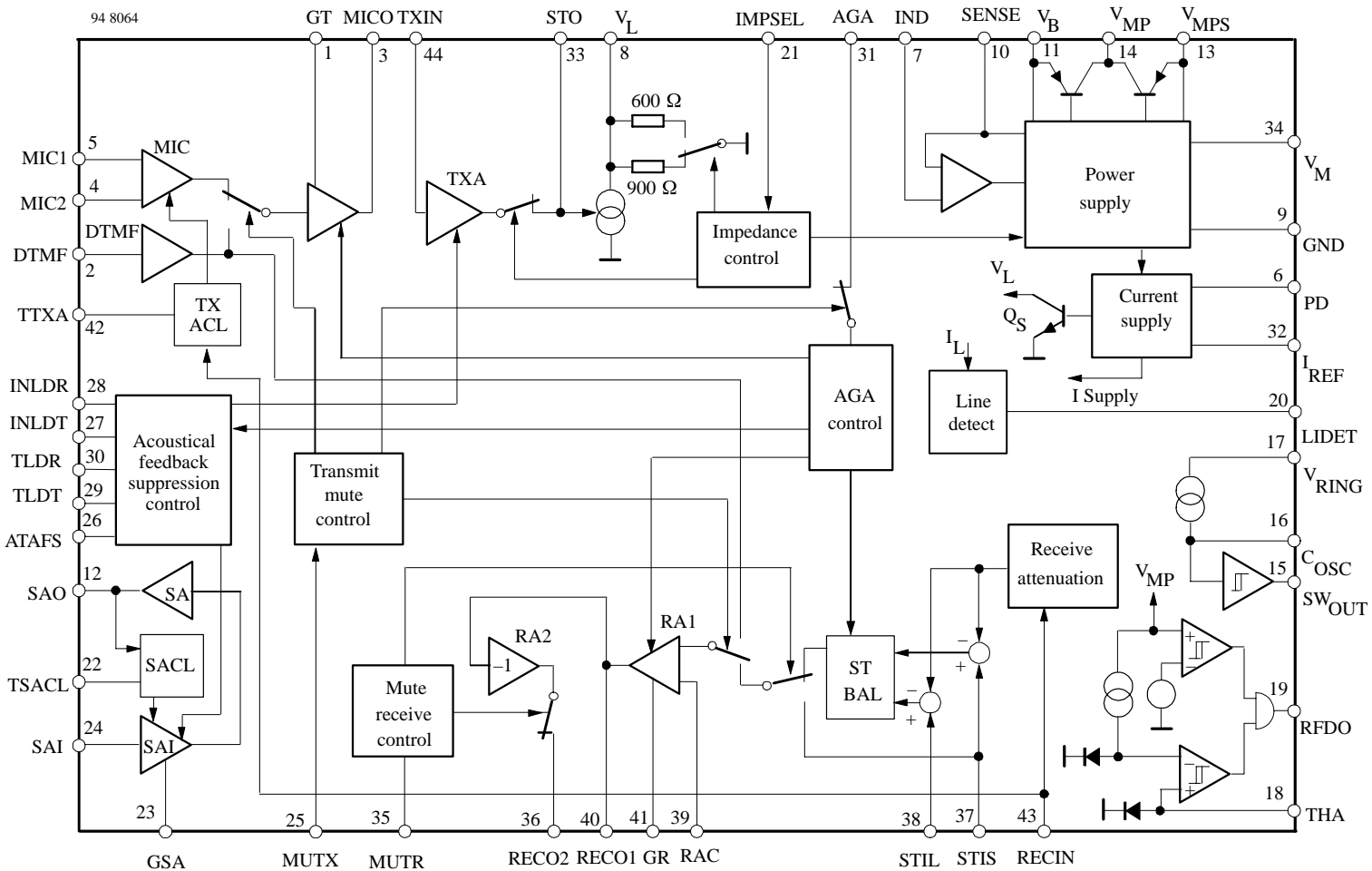
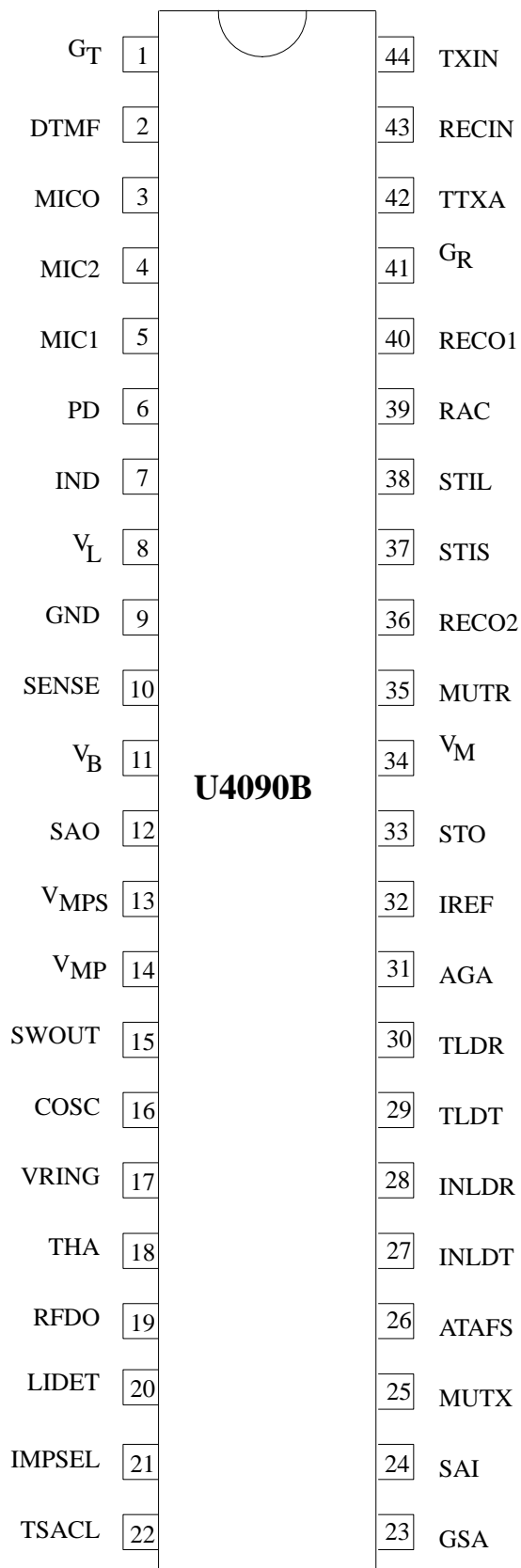

Figure 1. Detailed block diagram



## Pin Description

Pin	Symbol	Function
1	GT	A resistor from this pin to GND sets the amplification of microphone and DTMF signals, the input amplifier can be muted by applying VMP to GT.
2	DTMF	Input for DTMF signals, also used for the answering machine and hands-free input
3	MICO	Output of microphone preamplifier
4	MIC 2	Non-inverting input of microphone amplifier
5	MIC 1	Inverting input of microphone amplifier
6	PD	Active high input for reducing the current consumption of the circuit, simultaneously VL is shorted by an internal switch
7	IND	The internal equivalent inductance of the circuit is proportional to the value of the capacitor at this pin, a resistor connected to ground may be used to reduce the dc line voltage
8	VL	Line voltage
9	GND	Reference point for dc- and ac-output signals
10	SENSE	A small resistor (fixed) connected from this pin to VL sets the slope of the dc characteristic and also effects the line-length equalization characteristics and the line current at which the loudspeaker amplifier is switched on
11	VB	Unregulated supply voltage for peripheral circuits (voice switch), limited to typically 7 V
12	SAO	Output of loudspeaker amplifier
13	VMPS	Unregulated supply voltage for $\mu$ C, limited to 6.3 V
14	VMP	Regulated supply voltage 3.3 V for peripheral circuits (especially microprocessors), minimum output current: 2 mA (ringing) 4 mA (speech mode)
15	SWOUT	Output for driving external switching transistor
16	COSC	40-kHz oscillator for ringing power converter

94 7905 e

Pin	Symbol	Function
17	V <sub>RING</sub>	Input for ringing signal protected by internal zener diode
18	THA	Threshold adjustment for ringing frequency detector
19	RFDO	Output of ringing frequency detector
20	LIDET	Line detect; output is low when the line current is more than 15 mA
21	IMP-SEL	Control input for selection of line impedance 1. 600 Ω 2. 900 Ω 3. Mute of second transmit stage (TXA); also used for indication of external supply (answering machine); last chosen impedance is stored
22	TSACL	Time constant of anti-clipping of speaker amplifier
23	GSA	Current input for setting the gain of the speaker amplifier, adjustment characteristic is logarithmical, or RGSA > 2 MΩ, the speaker amplifier is switched off
24	SA I	Speaker amplifier input (for loudspeaker, tone ringer and hands-free use)
25	MUTX	Three-state input of transmit mute: 1) Speech condition; inputs MIC1 / MIC2 active 2) DTMF condition; input DTMF active a part of the input signal is passed to the receiving amplifier as a confidence signal during dialing 3) Input DTMF used for answering machine and hands-free use; receive branch not affected
26	ATAFS	Attenuation of acoustical feedback suppression, maximum attenuation of AFS circuit is set by a resistor at this pin, without the resistor, AFS is switched off
27	INLDT	Input of transmit level detector
28	INLDR	Input of receive level detector

Pin	Symbol	Function
29	TLDT	Time constant of transmit level detector
30	TLDR	Time constant of receive level detector
31	AGA	Automatic gain adjustment with line current a resistor connected from this pin to GND sets the starting point max. gain change: 6 dB.
32	IREF	Internal reference current generation; RREF = 62 kΩ; IREF = 20 μA
33	STO	Sidetone reduction output output resistance approx.: 300 Ω, maximum load impedance: 10 kΩ.
34	V <sub>M</sub>	Reference node for microphone-earphone and loudspeaker amplifier, supply for electret microphone (IM ≤ 700 μA)
35	MUTR	Three-state mute input 1. Normal operation 2. Mute of ear piece 3. Mute of RECIN signal Condition of earpiece mute is stored
36	RECO 2	Inverting output of receiving amplifier
37	STI S	Input for sidetone network (short loop) or for answering machine
38	STI L	Input for sidetone network (long loop)
39	RAC	Input of receiving amplifier for ac coupling in feedback path
40	RECO 1	Output of receiving amplifier
41	G <sub>R</sub>	A resistor connected from this pin to GND sets the receiving amplification of the circuit; amplifier RA1 can be muted by applying VMP to GR
42	TTXA	Time constant of anti-clipping in transmit path
43	RECIN	Input of receiving path; input impedance is typically 80 kΩ
44	TXIN	Input of intermediate transmit stage, input resistance is typically 20 kΩ

### DC Line Interface and Supply-Voltage Generation

The DC line interface consists of an electronic inductance and a dual-port output stage which charges the capacitors at  $V_{MPS}$  and  $V_B$ . The value of the equivalent inductance is given by:

$$L = R_{SENSE} \times C_{IND} \times ((R_{DC} \times R_{30}) / (R_{DC} + R_{30}))$$

In order to improve the supply during worst-case operating conditions, two PNP current sources -  $I_{BOPT}$  and

$I_{MPSOPT}$  - hand an extra amount of current to the supply voltages when the NPNs in parallel are unable to conduct current.

A flowchart for the control of the current sources (figure 3) shows how a priority for supply  $V_{MPS}$  is achieved.

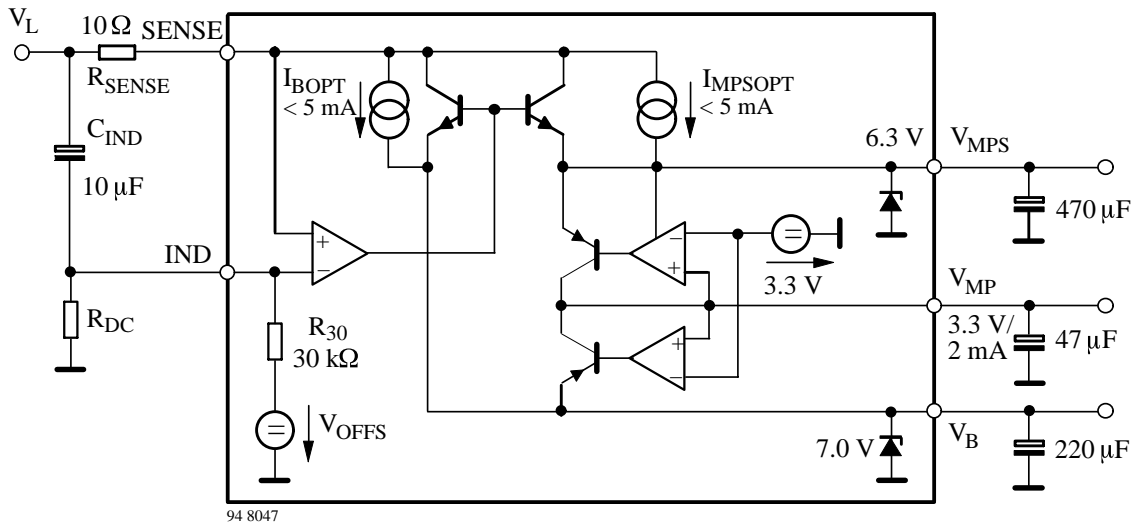

Figure 2. DC line interface with electronic inductance and generation of a regulated and an unregulated supply

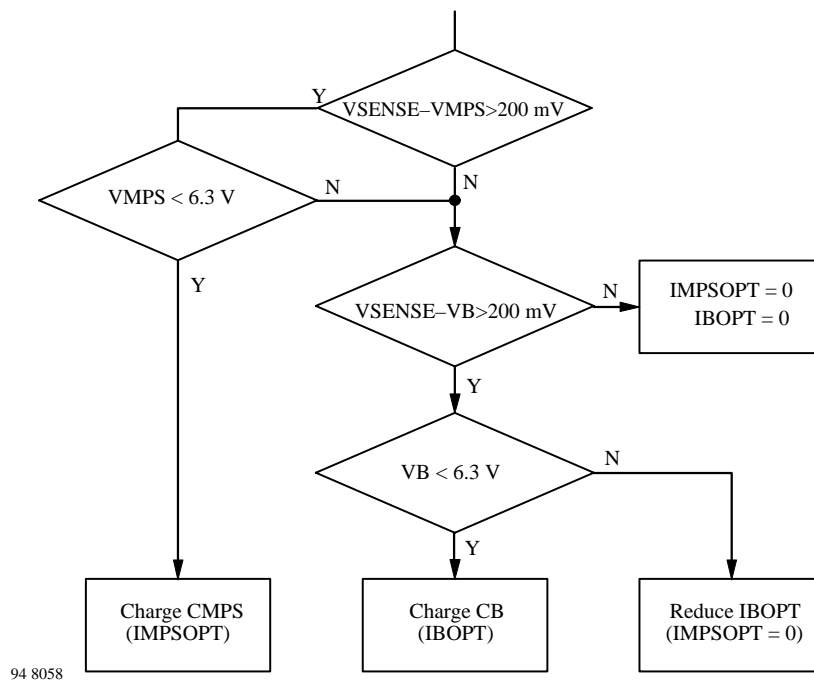

Figure 3. Supply capacitors CMPS and CB are charged with priority on CMPS

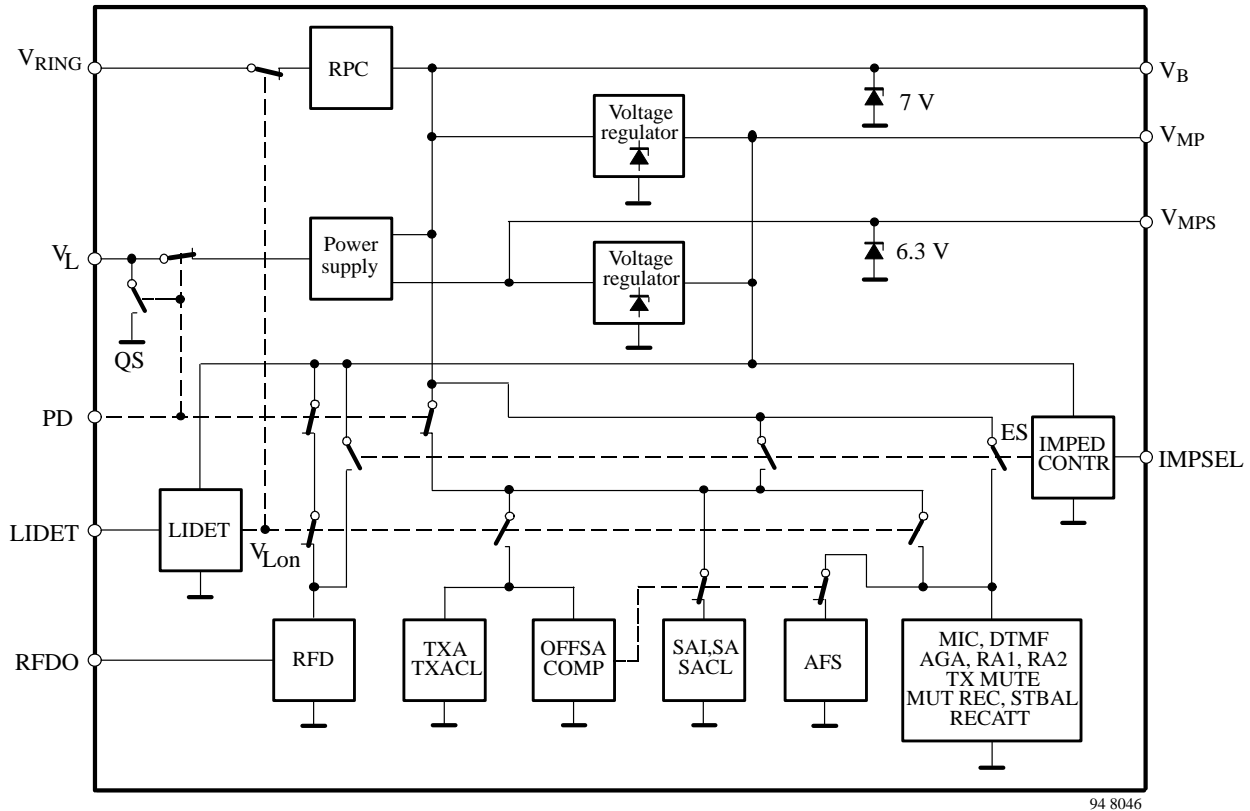

Figure 4. Supply of functional blocks is controlled by input voltages  $V_L$ ,  $V_B$ ,  $V_{RING}$  and by logic inputs  $PD$  and  $IMPSEL$

The U4090B contains two identical series regulators which provide a supply voltage  $V_{MP}$  of 3.3 V suitable for a microprocessor. In speech mode, both regulators are active because  $V_{MPS}$  and  $V_B$  are charged simultaneously by the DC-line interface. Output current is 4 mA. The capacitor at  $V_{MPS}$  is used to provide the microcomputer with sufficient power during long-line interruptions. Thus, long flash pulses can be bridged or a LCD display can be turned on for more than 2 seconds after going on hook. When the system is in ringing mode,  $V_B$  is charged by the on-chip ringing power converter. In this mode only one regulator is used to supply  $V_{MP}$  with max. 2 mA.

## Supply Structure of the Chip

As a major benefit the chip uses a very flexible system structure which allows simple realization of numerous applications such as:

- Group listening phone
- Hands-free phone
- Ringing with the built in speaker amplifier
- Answering machine with external supply

The special supply topology for the various functional blocks is illustrated in figure 4.

There are four major supply states:

1. Speech condition
2. Power down (pulse dialing)
3. Ringing
4. External supply

1. In speech condition the system is supplied by the line current. If the LIDET-block detects a line voltage above the fixed threshold (1.9 V), the internal signal  $V_{LON}$  is activated, thus switching off RFD and RPC and switching on all other blocks of the chip.

At line voltages below 1.9 V, the switches remain in their quiescent state as shown in the diagram.

OFFSACOMP disables the group listening feature (SAI, SA, SACL, AFS) below line currents of approximately 10 mA.

2. When the chip is in power-down mode ( $PD = high$ ), e.g., during pulse dialing, the internal switch QS shorts the line and all amplifiers are switched off. In this

condition, LIDET, voltage regulators and IMPED CONTR are the only active blocks.

3. During ringing, the supply for the system is fed into  $V_B$  via the ringing power converter (RPC). The only functional amplifiers are in the speaker amplifier section (SAI, SA, SACL).
4. In an answering machine, the chip is powered by an external supply via pin  $V_B$ . This application allows the possibility to activate all amplifiers (except the transmit line interface TXA). Selecting IMPSEL = high impedance activates all switches at the ES line.

**Acoustic Feedback Suppression**

Acoustical feedback from the loudspeaker to the handset microphone may cause instability in the system. The U4090B offers a very efficient feedback suppression

circuit, which uses a modified voice switch topology. Figure 5 shows the basic system configuration.

Two attenuators (TX ATT and RX ATT) reduce the critical loop gain by introducing an externally adjustable amount of loss either in the transmit or in the receive path. The sliding control in block ATT CONTR determines, whether the TX or the RX signal has to be attenuated. The overall loop gain remains constant under all operating conditions.

Selection of the active channel is made by comparison of the logarithmically compressed TX- and RX- envelope curve.

The system configuration for group listening, which is realized in the U4090B, is illustrated in figure 7. TXA and SAI represent the two attenuators, the logarithmic envelope detectors are shown in a simplified way (operational amplifiers with two diodes).

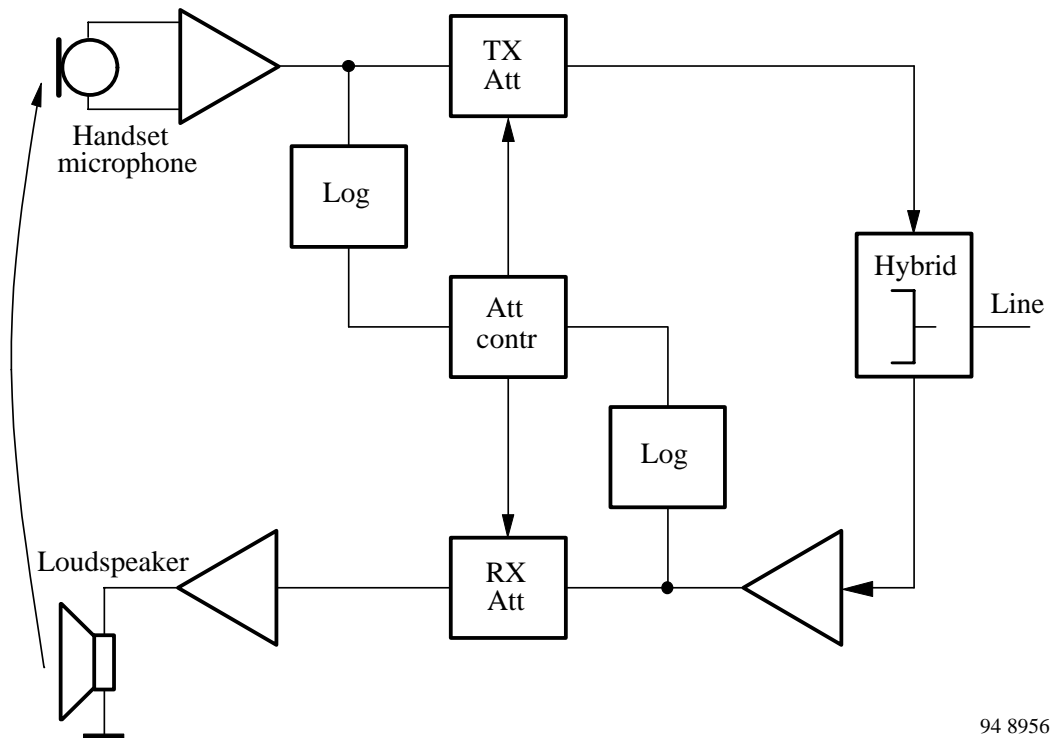
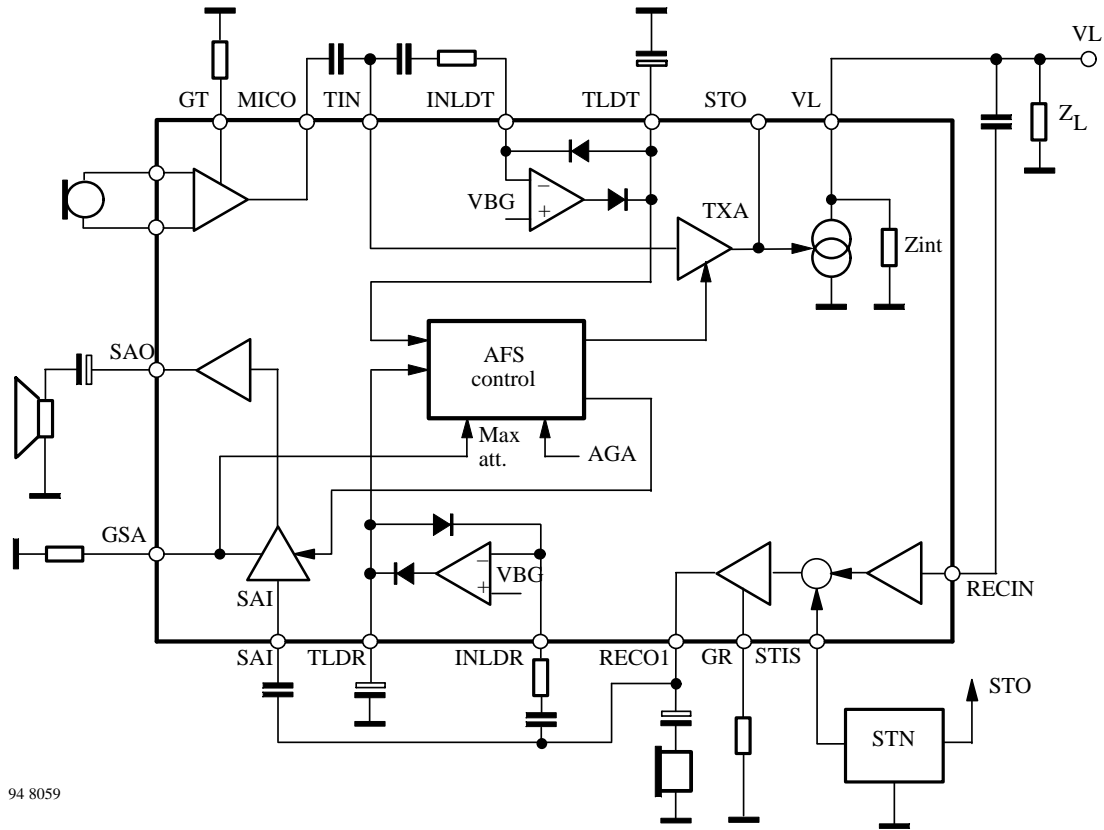

Figure 5. Basic voice switch system

94 8956



94 8059

Figure 6. Integration of acoustic feedback suppression circuit into the speech circuit environment

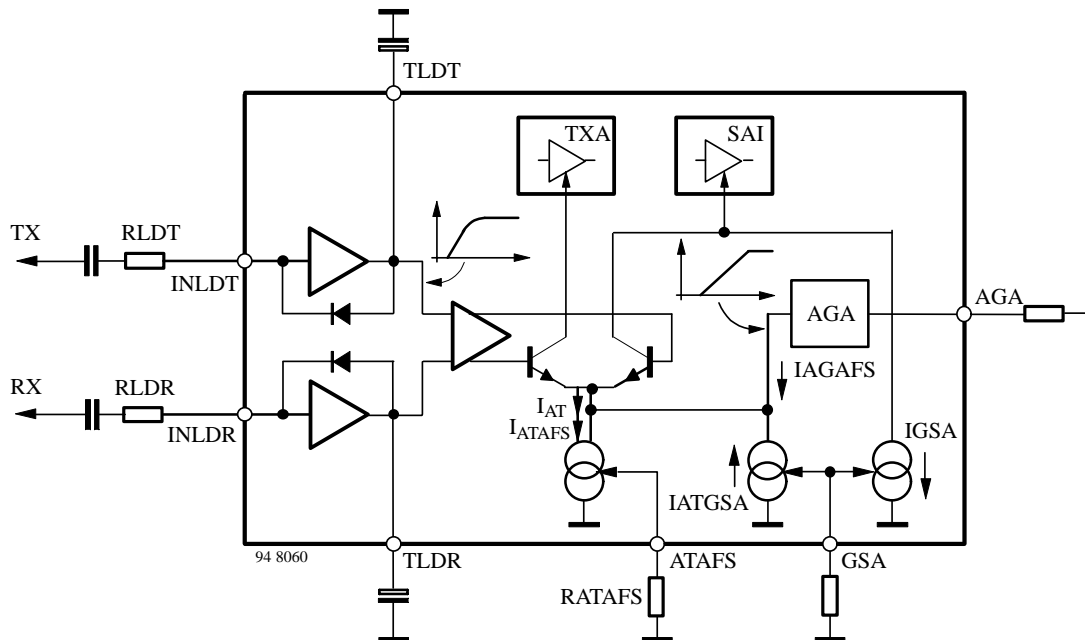

Figure 7. Acoustic feedback suppression by alternative control of transmit- and speaker amplifier gain



A detailed diagram of the AFS (acoustic feedback suppression) is given in figure 7. Receive and Transmit signals are first processed by logarithmic rectifiers in order to produce the envelopes of the speech at TLDT and RLDT. After amplification, a decision is made by the differential pair which direction should be transmitted.

The attenuation of the controlled amplifiers TXA and SAI is determined by the emitter current IAT which consists of three parts:

- I<sub>ATAS</sub> sets maximum attenuation
- I<sub>ATGSA</sub> decreases the attenuation when speaker amplifier gain is reduced
- I<sub>AGAFS</sub> decreases the attenuation according to the loop gain reduction caused by the AGA-function

$$I_{AT} = I_{ATAFS} - I_{ATGSA} - I_{AGAFS}$$

$$\Delta G = I_{AT} \times 0.67 \text{ dB}/\mu\text{A}$$

Figure 8 illustrates the principle relationship between speaker amplifier gain (GSA) and attenuation of AFS (ATAFS). Both parameters can be adjusted independently, but the internal coupling between them has to be considered. Maximum usable value of GSA is 36 dB. The shape of the characteristic is moved in the x-direction by adjusting resistor RATAFS, thus changing ATAFS<sub>m</sub>. The actual value of attenuation (ATAFS<sub>a</sub>), however, can be determined by reading the value which belongs to the actual gain GSA<sub>a</sub>. If the speaker amplifier gain is reduced, the attenuation of AFS is automatically reduced by the same amount in order to achieve a constant loop gain. Zero attenuation is set for speaker gains  $GSA \leq GSA_0 = 36 \text{ dB} - \text{ATAFS}_m$ .

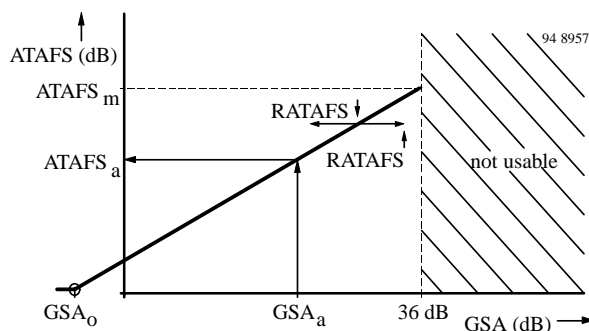

Figure 8. Reducing speaker amplifier gain results in an equal reduction of AFS attenuation

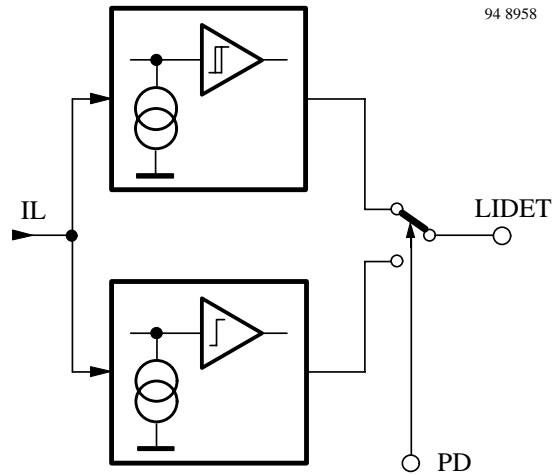

Figure 9. Line detection with two comparators for speech mode and pulse dialing

### Line Detection (LIDET)

The line current supervision is active under all operating conditions of the U4090B. In speech mode (PD = inactive), the line-current comparator uses the same thresholds as the comparator for switching off the entire speaker amplifier. The basic behavior is illustrated in figure 10. Actual values of I<sub>LOFF</sub>/I<sub>LOFF</sub> vary slightly with the adjustment of the DC characteristics and the selection of the internal line impedance.

When Power Down is activated (during pulse dialing), the entire line current flows through the short-circuiting transistor QS (see figure 4). As long as IL is above typ. 1.6 mA, output LIDET is low. This comparator does not use hysteresis.

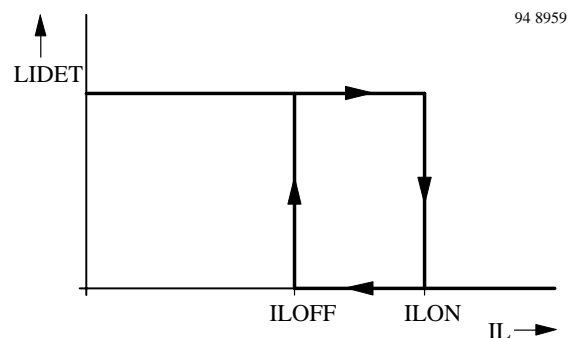

Figure 10. Line detection in speech mode with hysteresis

## Ringing Power Converter (RPC)

The RPC transforms the input power at VRING (high voltage/ low current) into an equivalent output power at VB (low voltage/ high current) which is capable of driving the low-ohmic loudspeaker. Input impedance at VRING is fixed at 5 kΩ and the efficiency of the step-down converter is approx. 65%.

## Ringing Frequency Detector (RFD)

The U4090B offers an output signal for the micro-controller, which is a digital representation of the double ringing frequency. It is generated by a current comparator with hysteresis. The input voltage VRING is transformed into a current via RTHA. The thresholds are 8 μA and 24 μA. RFDO and VRING are in phase. A second comparator with hysteresis is used to enable the output RFDO as long as the supply voltage for the microprocessor VMP is above 2.0 V.

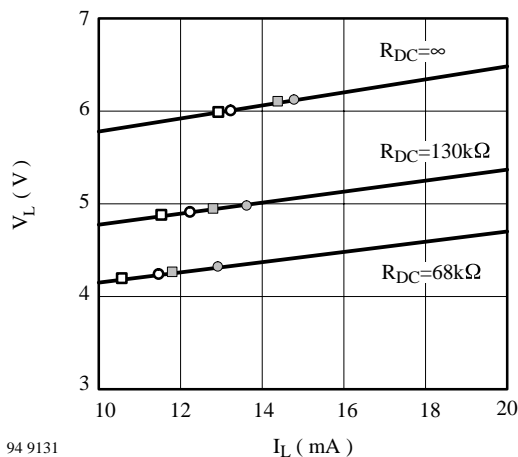

94 9131

- = ILOON at line impedance = 600 Ω
- = ILOFF at line impedance = 600 Ω
- = ILOON at line impedance = 900 Ω
- ◊ = ILOFF at line impedance = 900 Ω

Figure 11. Comparator thresholds depending on dc mask and line impedance

## Absolute Maximum Ratings

Parameters	Symbol	Value	Unit
Line current	$I_L$	140	mA
DC line voltage	$V_L$	12	V
Maximum input current	Pin 17 $I_{RING}$	15	mA
Junction temperature	$T_j$	125	°C
Ambient temperature	$T_{amb}$	-25 to +75	°C
Storage temperature	$T_{stg}$	-55 to +150	°C
Total power dissipation, $T_{amb} = 60^\circ\text{C}$	$P_{tot}$	0.9	W

## Thermal Resistance

Parameters	Symbol	Value	Unit
Junction ambient SSO44	$R_{thJA}$	70	K/W

## Electrical Characteristics

$f = 1 \text{ kHz}$ ,  $0 \text{ dBm} = 775 \text{ mV}_{\text{rms}}$ ,  $I_M = 0.3 \text{ mA}$ ,  $I_{MP} = 2 \text{ mA}$ ,  $RDC = 130 \text{ k}\Omega$ ,  $T_{\text{amb}} = 25^\circ\text{C}$ ,  $RGSA = 560 \text{ k}\Omega$ ,  $Z_{\text{ear}} = 68 \text{ nF} + 100 \text{ }\Omega$ ,  $Z_M = 68 \text{ nF}$ , Pin 31 open,  $V_{\text{IMPSEL}} = \text{GND}$ ,  $V_{\text{MUTX}} = \text{GND}$ ,  $V_{\text{MUTR}} = \text{GND}$ , unless otherwise specified.

Parameters	Test Conditions / Pin	Symbol	Min.	Typ.	Max.	Unit	Figure
<b>DC characteristics</b>							
DC voltage drop over circuit	$I_L = 2 \text{ mA}$	$V_L$	4.6	2.4 5.0 7.5 9.4	5.4	V	20
	$I_L = 14 \text{ mA}$						
	$I_L = 60 \text{ mA}$						
	$I_L = 100 \text{ mA}$						
<b>Transmission amplifier, <math>I_L = 14 \text{ mA}</math>, <math>V_{\text{MIC}} = 2 \text{ mV}</math>, <math>RGT = 27 \text{ k}\Omega</math>, unless otherwise specified</b>							
Range of transmit gain		$G_T$	40	45	50	dB	21
Transmitting amplification	$RGT = 12 \text{ k}\Omega$ $RGT = 27 \text{ k}\Omega$	$G_T$	47 39.8	48	49 41.8	dB	21
Frequency response	$I_L \geq 14 \text{ mA}$ , $f = 300 \text{ to } 3400 \text{ Hz}$	$\Delta G_T$			$\pm 0.5$	dB	21
Gain change with current	Pin 31 open $I_L = 14 \text{ to } 100 \text{ mA}$	$\Delta G_T$			$\pm 0.5$	dB	21
Gain deviation	$T_{\text{amb}} = -10 \text{ to } +60^\circ\text{C}$	$\Delta G_T$			$\pm 0.5$	dB	21
CMRR of microphone amplifier		CMRR	60	80		dB	21
Input resistance of MIC amplifier	$RGT = 12 \text{ k}\Omega$ $RGT = 27 \text{ k}\Omega$	$R_i$	45	50 75	110	$\text{k}\Omega$	21
Distortion at line	$I_L > 14 \text{ mA}$ $V_L = 700 \text{ mV}_{\text{rms}}$	$d_t$			2	%	21
Maximum output voltage	$I_L > 19 \text{ mA}$ , $d < 5\%$ $V_{\text{mic}} = 25 \text{ mV}$ $CTXA = 1 \text{ }\mu\text{F}$	$V_{L\text{max}}$	1.8	3	4.2	dBm	21
	IMPSEL = open $RGT = 12 \text{ k}\Omega$	$V_{\text{MICOMax}}$		-5.2		dBm	21
Noise at line psophometrically weighted	$I_L > 14 \text{ mA}$ $G_T = 48 \text{ dB}$	no		-80	-72	dBmp	21
Anti-clipping attack time release time	$CTXA = 1 \text{ }\mu\text{F}$ each 3 dB overdrive			0.5 9		ms	21
Gain at low operating current	$I_L = 10 \text{ mA}$ $I_{MP} = 1 \text{ mA}$ $RDC = 68 \text{ k}\Omega$ $V_{\text{mic}} = 1 \text{ mV}$ $I_M = 300 \text{ }\mu\text{A}$	$G_T$	40		42.5	dB	21
Distortion at low operating current	$I_L = 10 \text{ mA}$ $I_M = 300 \text{ }\mu\text{A}$ $I_{MP} = 1 \text{ mA}$ $RDC = 68 \text{ k}\Omega$ $V_{\text{mic}} = 10 \text{ mV}$	$d_t$			5	%	21
Line loss compensation	$I_L = 100 \text{ mA}$ , $RAGA = 20 \text{ k}\Omega$	$\Delta G_{TI}$	-6.4	-5.8	-5.2	dB	21
Mute suppression							
a) MIC muted (microphone preamplifier)	$I_L \geq 14 \text{ mA}$ $\text{Mutx} = \text{open}$	$G_{TM}$	60	80		dB	21
b) TXA muted (second stage)	IMPSEL = open	$G_{TTX}$	60			dB	21

## Electrical Characteristics (continued)

Parameters	Test Conditions / Pin	Symbol	Min.	Typ.	Max.	Unit	Figure
<b>Receiving amplifier, <math>I_L = 14</math> mA, RGR = 62 k, unless otherwise specified, <math>V_{GEN} = 300</math> mV</b>							
Adjustment range of receiving gain	$I_L \geq 14$ mA, single ended differential MUTR = GND	$G_R$	-8 -2		+2 +8	dB	22
Receiving amplification	RGR = 62 k $\Omega$ differential RGR = 22 k $\Omega$ differential	$G_R$	-1.75	-1 7.5	-0.25	dB	22
Amplification of DTMF signal from DTMF IN to RECO 1, 2	$I_L \geq 14$ mA $V_{MUTX} = V_{MP}$	$G_{RM}$	7	10	13	dB	22
Frequency response	$I_L > 14$ mA, $f = 300$ to 3400 Hz	$\Delta G_{RF}$			$\pm 0.5$	dB	22
Gain change with current	$I_L = 14$ to 100 mA	$\Delta G_R$			$\pm 0.5$	dB	22
Gain deviation	$T_{amb} = -10$ to $+60^\circ\text{C}$	$\Delta G_R$			$\pm 0.5$	dB	22
Ear-protection differential	$I_L \geq 14$ mA $V_{GEN} = 11$ V <sub>rms</sub>	EP			2.2	V <sub>rms</sub>	22
MUTE suppression a) RECAT1 b) RA2 c) DTMF operation	$I_L \geq 14$ mA MUTR = open $V_{MUTR} = V_{MP}$ $V_{MUTX} = V_{MP}$	$\Delta G_R$	60			dB	22
Output voltage $d \leq 2\%$ differential	$I_L = 14$ mA $Z_{ear} = 68$ nF + 100 $\Omega$		0.775			V <sub>rms</sub>	22
Maximum output current $d \leq 2\%$	$Z_{ear} = 100$ $\Omega$		4			mA (peak)	22
Receiving noise psophometrically weighted	$Z_{ear} = 68$ nF + 100 $\Omega$ $I_L \geq 14$ mA	ni		-80	-77	dBmp	22
Output resistance	each output against GND	$R_o$			10	$\Omega$	22
Line loss compensation	RAGA = 20 k $\Omega$ , $I_L = 100$ mA	$\Delta G_{RI}$	-7.0	-6.0	-5.0	dB	22
Gain at low operating current	$I_L = 10$ mA $I_{MP} = 1$ mA $I_M = 300$ $\mu\text{A}$ $V_{GEN} = 560$ mV RDC = 68 k $\Omega$	$G_R$	-2	-1	0	dB	22
AC impedance	$V_{IMPSEL} = \text{GND}$ $V_{IMPSEL} = V_{MP}$	$Z_{imp}$ $Z_{imp}$	570 840	600 900	640 960	$\Omega$ $\Omega$	22
Distortion at low operating current	$I_L = 10$ mA $I_{MP} = 1$ mA $V_{GEN} = 560$ mV RDC = 68 k $\Omega$	dR			5	%	22

## Electrical Characteristics (continued)

Parameters	Test Conditions / Pin	Symbol	Min.	Typ.	Max.	Unit	Figure
<b>Speaker amplifier</b>							
Minimum line current for operation	No ac signal	$I_{Lmin}$			15	mA	23
Input resistance	Pin 24		14		22	k $\Omega$	23
Gain from SAI to SAO	$V_{SAI} = 3$ mV, $I_L = 15$ mA, $R_{GSA} = 560$ k $\Omega$ $R_{GSA} = 20$ k $\Omega$	$G_{SA}$	35.5	36.5 -3	37.5	dB	23
Output power	Load resistance $R_L = 50$ $\Omega$ , $d < 5\%$ $V_{SAI} = 20$ mV $I_L = 15$ mA $I_L = 20$ mA	$P_{SA}$ $P_{SA}$	3	7 20		mW	23
Output noise (Input SAI open) psophometrically weighted	$I_L > 15$ mA	$n_{SA}$			200	$\mu$ V <sub>psoph</sub>	23
Gain deviation	$I_L = 15$ mA $T_{amb} = -10$ to $+60^\circ$ C	$\Delta G_{SA}$			$\pm 1$	dB	23
Mute suppression	$I_L = 15$ mA, $V_L = 0$ dBm, $V_{SAI} = 4$ mV Pin 23 open	VSAO			-60	dBm	23
Gain change with current	$I_L = 15$ to 100 mA	$\Delta G_{SA}$			$\pm 1$	dB	23
Resistor for turning off speaker amplifier	$I_L = 15$ to 100 mA	$R_{GSA}$	0.8	1.3	2	M $\Omega$	23
Gain change with frequency	$I_L = 15$ mA $f = 300$ to 3400 Hz	$\Delta G_{SA}$			$\pm 0.5$	dB	23
Attack time of anti-clipping	20 dB over drive	tr		5		ms	23
Release time of anti-clipping		tf		80		ms	23
<b>DTMF amplifier</b> <b>Test conditions: IMP = 2 mA, IM = 0.3 mA, V<sub>MUTX</sub> = VMP</b>							
Adjustment range of DTMF gain	$I_L = 15$ mA Mute active	$G_D$	40		50	dB	24
DTMF amplification	$I_L = 15$ mA, $V_{DTMF} = 8$ mV Mute active: MUTX = VMP	$G_D$	40.7	41.7	42.7	dB	24
Gain deviation	$I_L = 15$ mA $T_{amb} = -10$ to $+60^\circ$ C	$G_D$			$\pm 0.5$	dB	24
Input resistance	$R_{GT} = 27$ k $\Omega$ , $R_{GT} = 15$ k $\Omega$	$R_i$	60 26	180 70	300 130	k $\Omega$	24
Distortion of DTMF signal	$I_L \geq 15$ mA $V_L = 0$ dBm	$d_D$			2	%	24
Gain deviation with current	$I_L = 15$ to 100 mA	$\Delta G_D$			$\pm 0.5$	dB	24

## Electrical Characteristics (continued)

Parameters	Test Conditions / Pin	Symbol	Min.	Typ.	Max.	Unit	Figure
<b>AFS acoustic feedback suppression</b>							
Adjustment range of attenuation	$I_L \geq 15 \text{ mA}$		0		50	dB	23
Attenuation of transmit gain	$I_L \geq 15 \text{ mA}$ , $I_{INLDT} = 0 \text{ } \mu\text{A}$ $R_{ATAFS} = 30 \text{ k}\Omega$ $I_{INLDR} = 10 \text{ } \mu\text{A}$	$\Delta G_T$		45		dB	23
Attenuation of speaker amplifier	$I_L \geq 15 \text{ mA}$ $I_{INLDP} = 0 \text{ } \mu\text{A}$ $R_{ATAFS} = 30 \text{ k}\Omega$ $I_{INLDR} = 10 \text{ } \mu\text{A}$	$\Delta G_{SA}$		50		dB	23
AFS disable	$I_L \geq 15 \text{ mA}$	$V_{ATAFS}$	1.5			V	23
<b>Supply voltages, <math>V_{mic} = 25 \text{ mV}</math>, <math>T_{amb} = -10 \text{ to } +60^\circ\text{C}</math></b>							
$V_{MP}$	$I_L = 14 \text{ mA}$ , RDC = 68 k $\Omega$ $I_{MP} = 2 \text{ mA}$	$V_{MP}$	3.1	3.3	3.5	V	20
$V_{MPS}$	$I_L = 100 \text{ mA}$ RDC = inf., $I_{MP} = 0 \text{ mA}$	$V_{MPS}$			6.7	V	20
$V_M$	$I_L \geq 14 \text{ mA}$ , $I_M = 700 \text{ } \mu\text{A}$ RDC = 130 k $\Omega$	$V_M$	1.3		3.3	V	20
$V_B$	$I_B = +20 \text{ mA}$ , $I_L = 0 \text{ mA}$	$V_B$		7	7.6	V	20
<b>Ringing power converter, <math>I_{MP} = 1 \text{ mA}</math>, <math>I_M = 0</math></b>							
Maximum output power	$V_{RING} = 20.6 \text{ V}$	$P_{SA}$		20		mW	25
Threshold of ring frequency detector	RFDO: low to high $V_{HYST} = V_{RINGON} - V_{RINGOFF}$	$V_{RINGON}$ $V_{HYST}$		17.5 11.0		V	25
Input impedance	$V_{RING} = 30 \text{ V}$	$R_{RING}$	4	5	6	k $\Omega$	25
Input impedance in speech mode	$f = 300 \text{ Hz to } 3400 \text{ Hz}$ $I_L > 15 \text{ mA}$ , $V_{RING} = 20\text{V} + 1.5V_{rms}$	$R_{RINGSP}$	150			k $\Omega$	25
Logic level of frequency detector	$V_{RING} = 0 \text{ V}$ $V_B = 4 \text{ V}$ $V_{RING} = 25 \text{ V}$	$V_{RFDO}$		0 VMP		V	25
Ring detector enable	$V_{RING} = 25 \text{ V}$ , RFDO high	$V_{MPON}$	1.8	2.0	2.2	V	25
Zener diode voltage	$I_{RING} = 25 \text{ mA}$	$V_{RINGmax}$	30.8		33.3	V	25

## Electrical Characteristics (continued)

Parameters	Test Conditions / Pin	Symbol	Min.	Typ.	Max.	Unit	Figure
<b>MUTR Input</b>							
MUTR input current	VMUTR = GND I <sub>L</sub> > 14 mA VMUTR = V <sub>MP</sub>	I <sub>MUTE</sub>		-20 +10	-30	μA	26
MUTR input voltage	Mute low; I <sub>L</sub> > 14 mA	V <sub>MUTE</sub>			0.3	V	26
	Mute high; I <sub>L</sub> > 14 mA	V <sub>MUTE</sub>	V <sub>MP-0.3</sub> V			V	26
<b>PD Input</b>							
PD input current	PD active, I <sub>L</sub> > 14 mA V <sub>PD</sub> = V <sub>MP</sub>	I <sub>pd</sub>		9		uA	26
Input voltage	PD = active PD = inactive	V <sub>pd</sub> V <sub>pd</sub>	2		0.3	V	26
Voltage drop at V <sub>L</sub>	I <sub>L</sub> = 14 mA, PD = active	V <sub>L</sub>		1.5		V	26
	I <sub>L</sub> = 100 mA, PD = active	V <sub>L</sub>		1.9			
<b>Input characteristics of IMPSEL</b>							
Input current	I <sub>L</sub> ≥ 14 mA V <sub>IMPSEL</sub> = V <sub>MP</sub> V <sub>IMPSEL</sub> = GND	I <sub>IMPSEL</sub> I <sub>IMPSEL</sub>		18 -18		μA μA	26
Input voltage	Input high	V <sub>IMPSEL</sub>	V <sub>MP-0.3</sub> V			V	26
	Input low	V <sub>IMPSEL</sub>			0.3	V	26
<b>MUTX input</b>							
Input current	V <sub>MUTX</sub> = V <sub>MP</sub> V <sub>MUTX</sub> = GND	I <sub>MUTX</sub> I <sub>MUTX</sub>		20 -20	30 -30	μA μA	26
Input voltage	Input high	V <sub>MUTX</sub>	V <sub>MP-0.3</sub> V			V	26
	Input low	V <sub>MUTX</sub>			0.3	V	26
<b>Line detection</b>							
Line current for LIDET active	PD = inactive	ILON		12.6		mA	20
Line current for LIDET inactive	PD = inactive	ILOFF		11.0		mA	20
Current threshold during power down	V <sub>B</sub> = 5 V, PD = active	ILONPD	0.8	1.6	2.4	mA	20

## U 4090 B - Control

IMPSEL	MODE
0	Line-impedance = 600 Ω TXA = on ES = off
0 to Z	Line-impedance = 600 Ω TXA = off ES = on
1 to Z	Line-impedance = 900 Ω TXA = off ES = on
1	Line-impedance = 900 Ω TXA = on ES = off

MUTX	MODE
0	MIC 1/2 transmit enabled receive enable AFS = on AGA = on TXACL = on
Z	DTMF transmit enabled receive enable AFS = on AGA = on TXACL = on
1	DTMF transmit enabled DTMF to receive enable AFS = off AGA = off TXACL = off

MUTR	MODE
0	RA2 = on RECATT = on STIS + STIL = on
0 to Z	RA2 = on RECATT = off STIS = on, STIL = off
1 to Z	RA2 = off RECATT = off STIS = on, STIL = off AGA off for STIS
1	RA2 = off RECATT = on STIS + STIL = on

Logic-level
0 = < (0.3 V)
Z = > (1 V) < (VMP - 1 V) or (open input)
1 = > (VMP - 0.3 V)

RECATT = Receive attenuation  
 STIS, STIL = Inputs of sidetone balancing amplifiers  
 ES = External supply  
 AFS = Acoustic feedback suppression control  
 AGA = Automatic gain adjustment  
 RA2 = Inverting receive amplifier  
 TXACL = Transmit anti-clipping control

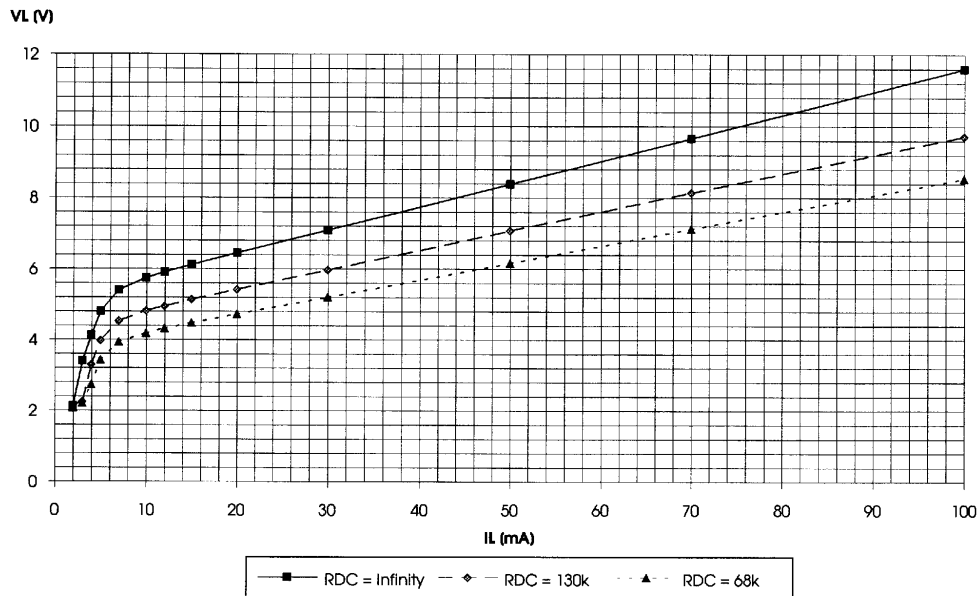

94 8856

Figure 12. Typical DC characteristic



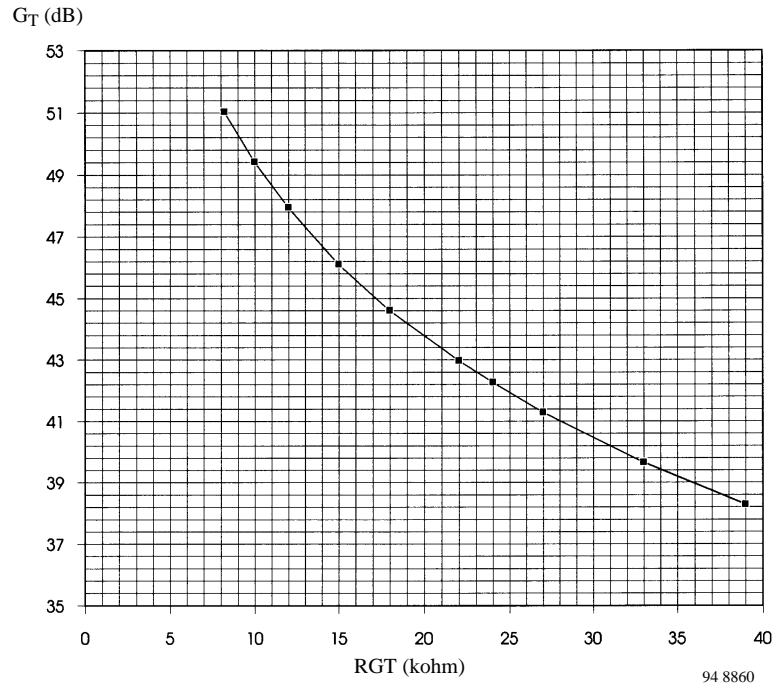

Figure 13. Typical adjustment range of transmit gain

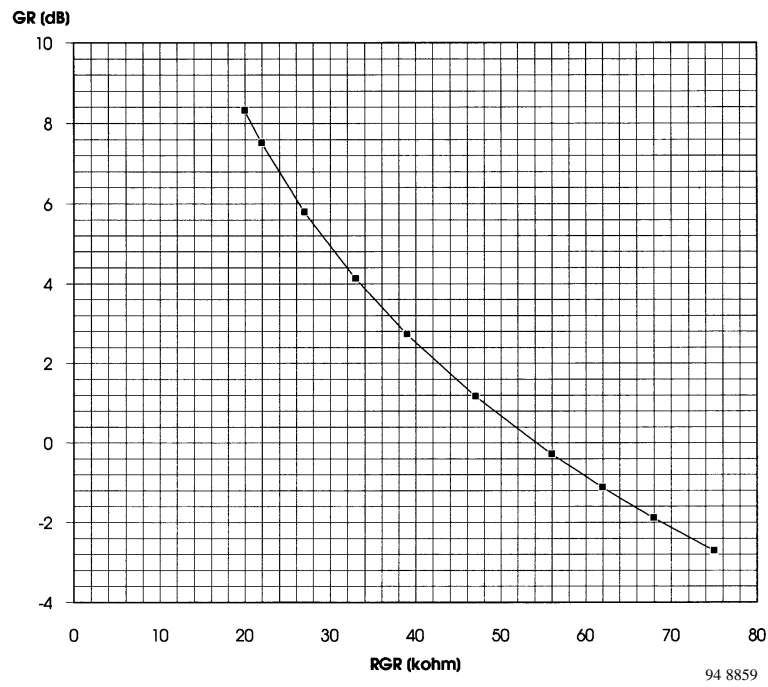

Figure 14. Typical adjustment range of receive gain (differential output)

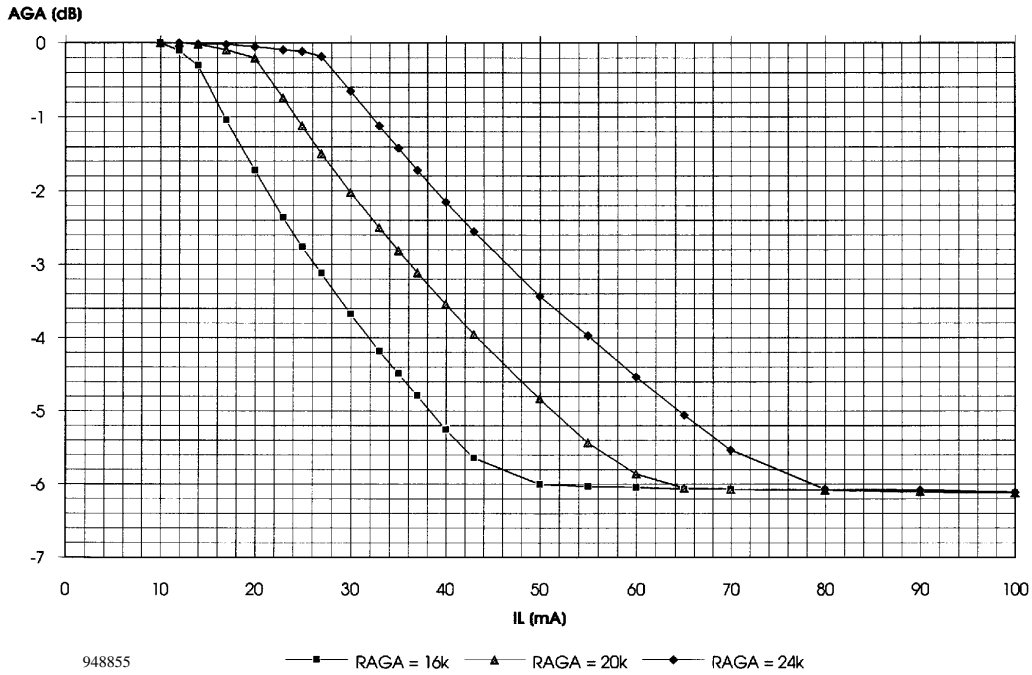

Figure 15. Typical AGA characteristic

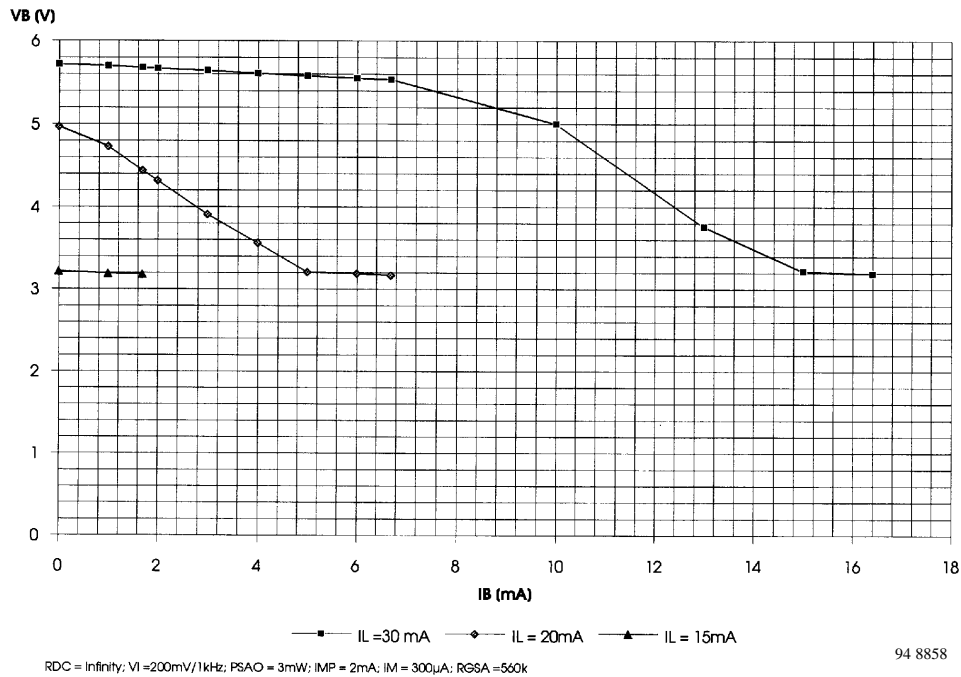

Figure 16. Typical load characteristic of  $V_B$  for a maximum (RDC = infinity) DC-characteristic and 3-mW loudspeaker output

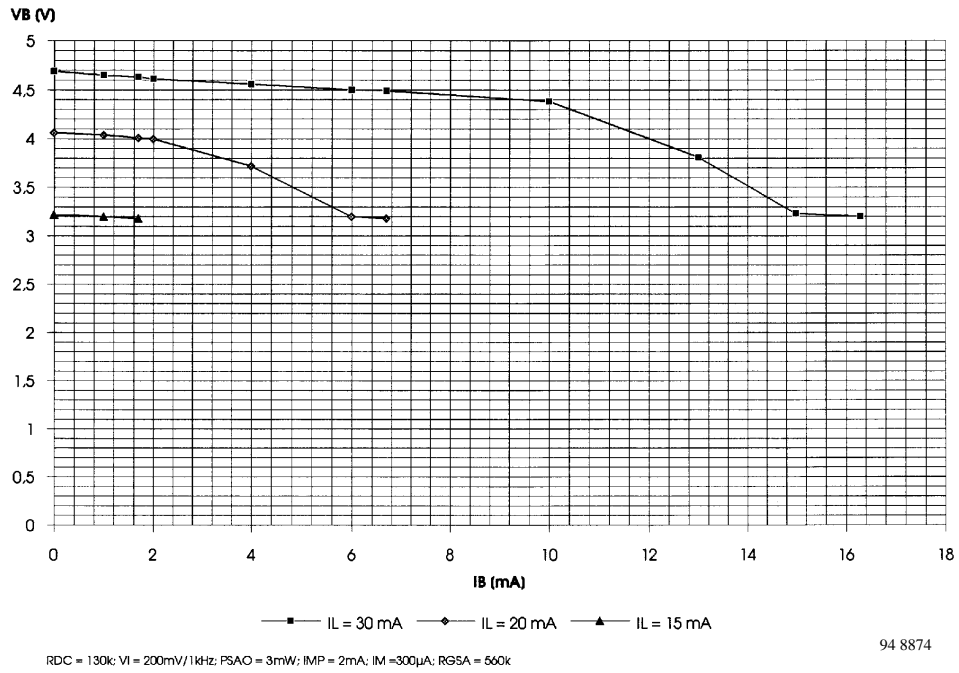

Figure 17. Typical load characteristic of  $V_B$  for a medium DC-characteristic (RDC = 130 k $\Omega$ ) and 3-mW loudspeaker output

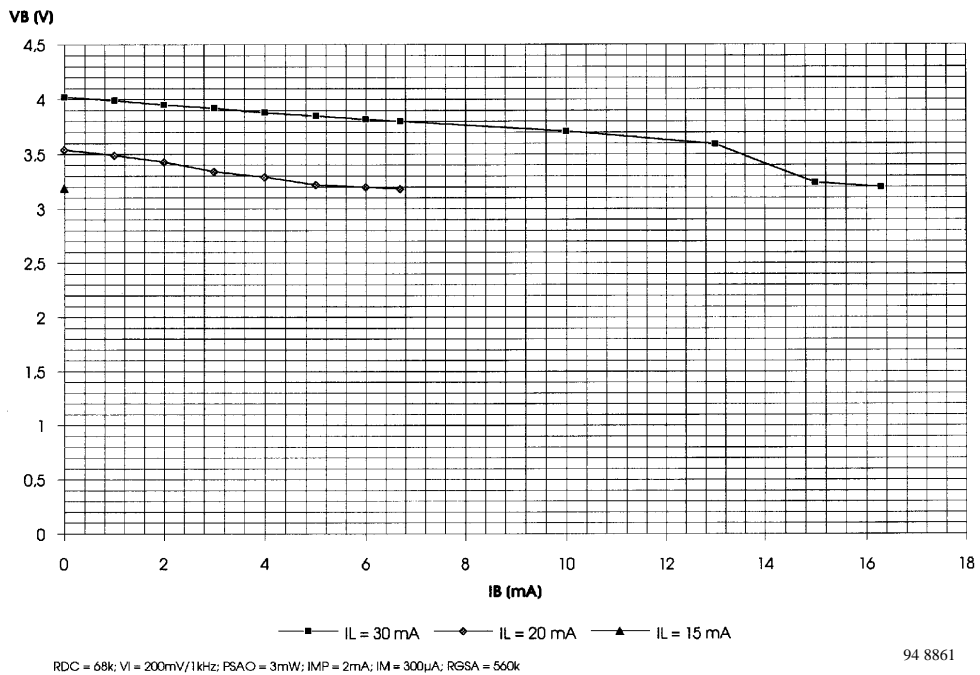

Figure 18. Typical load characteristic of  $V_B$  for a minimum DC-characteristic (RDC = 68 k $\Omega$ ) and 3-mW loudspeaker output

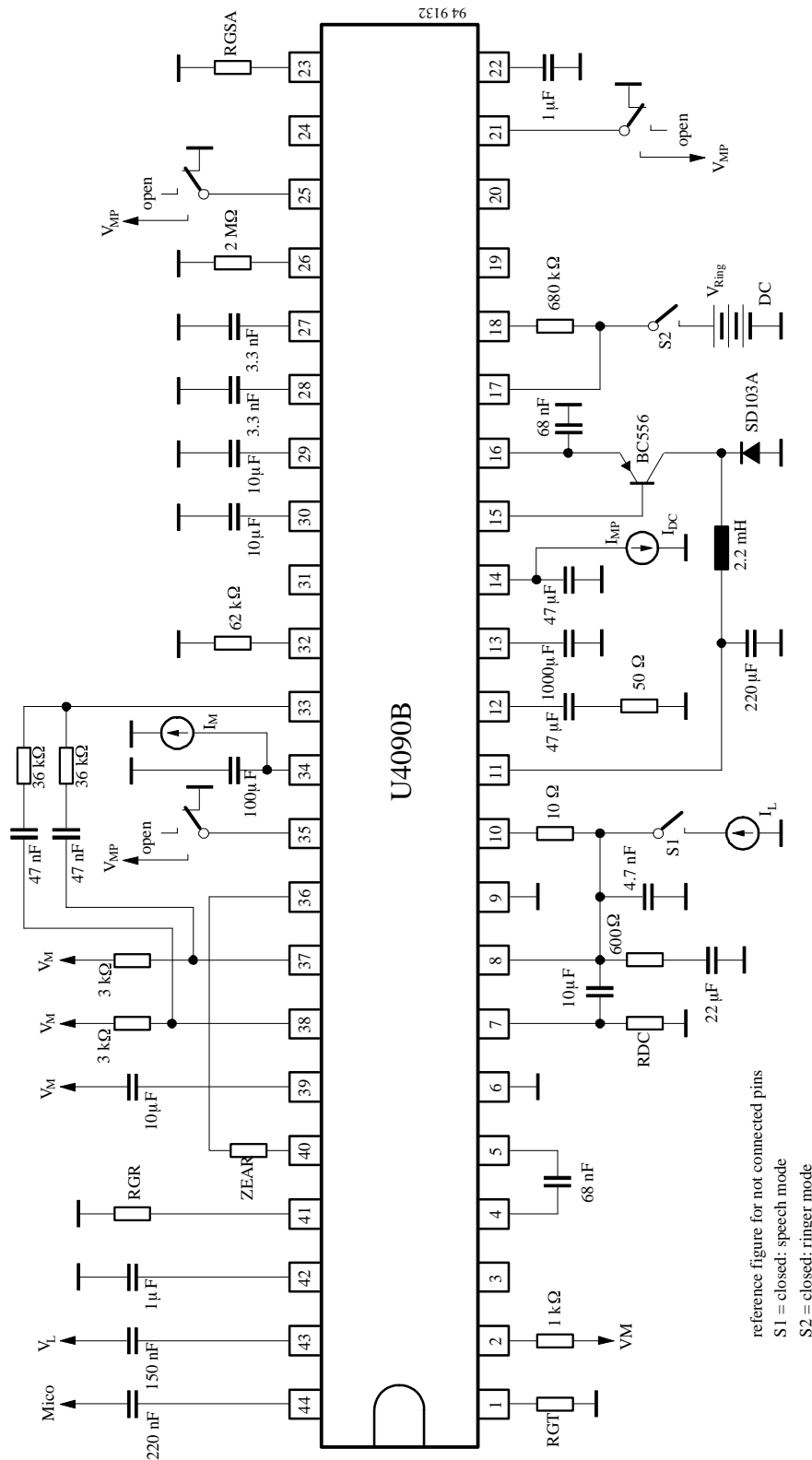

Figure 19. Basic test circuit

reference figure for not connected pins  
S1 = closed: speech mode  
S2 = closed: ringer mode

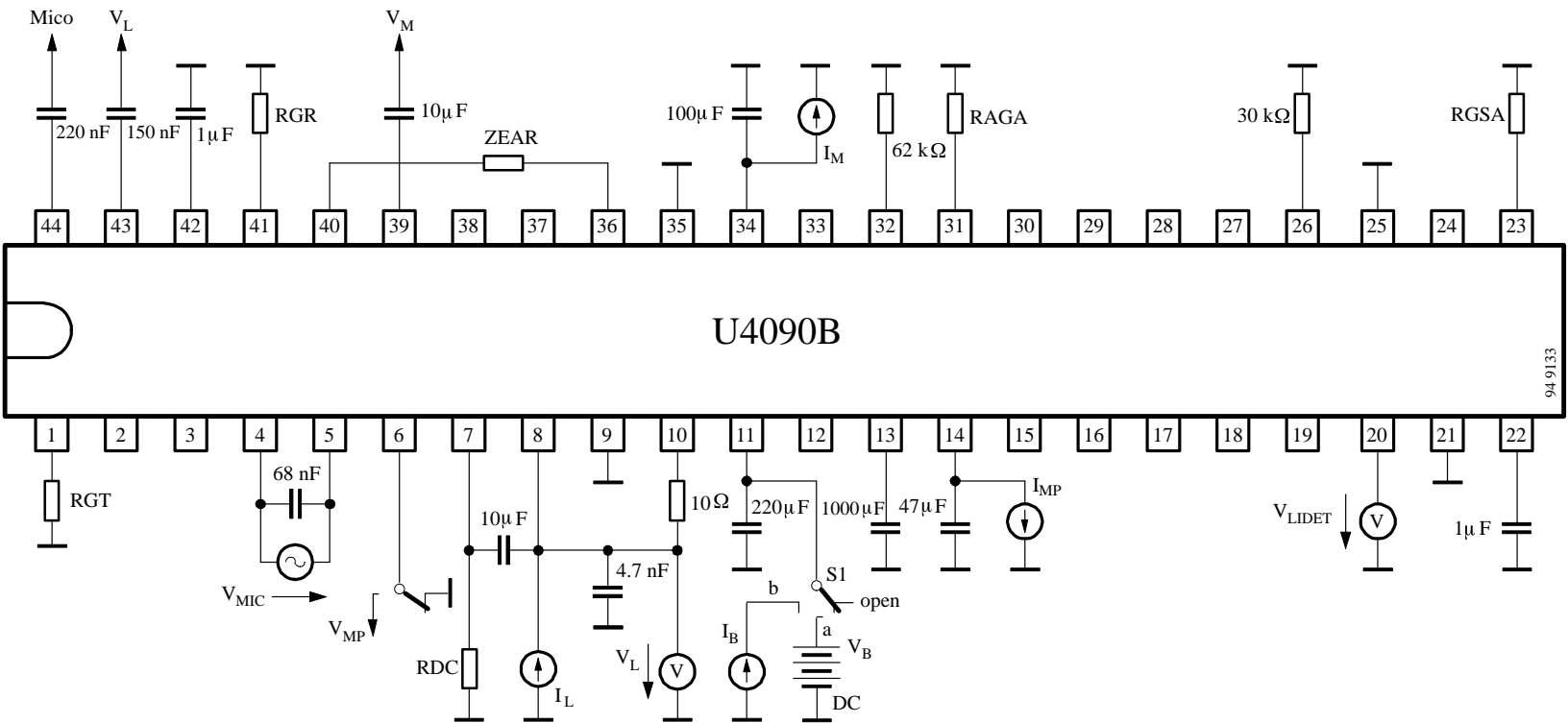

Figure 20. DC characteristics, line detection

Line detection: S1a  
 VB (external supply): S1b  
 open pins should be connected as shown in figure 25

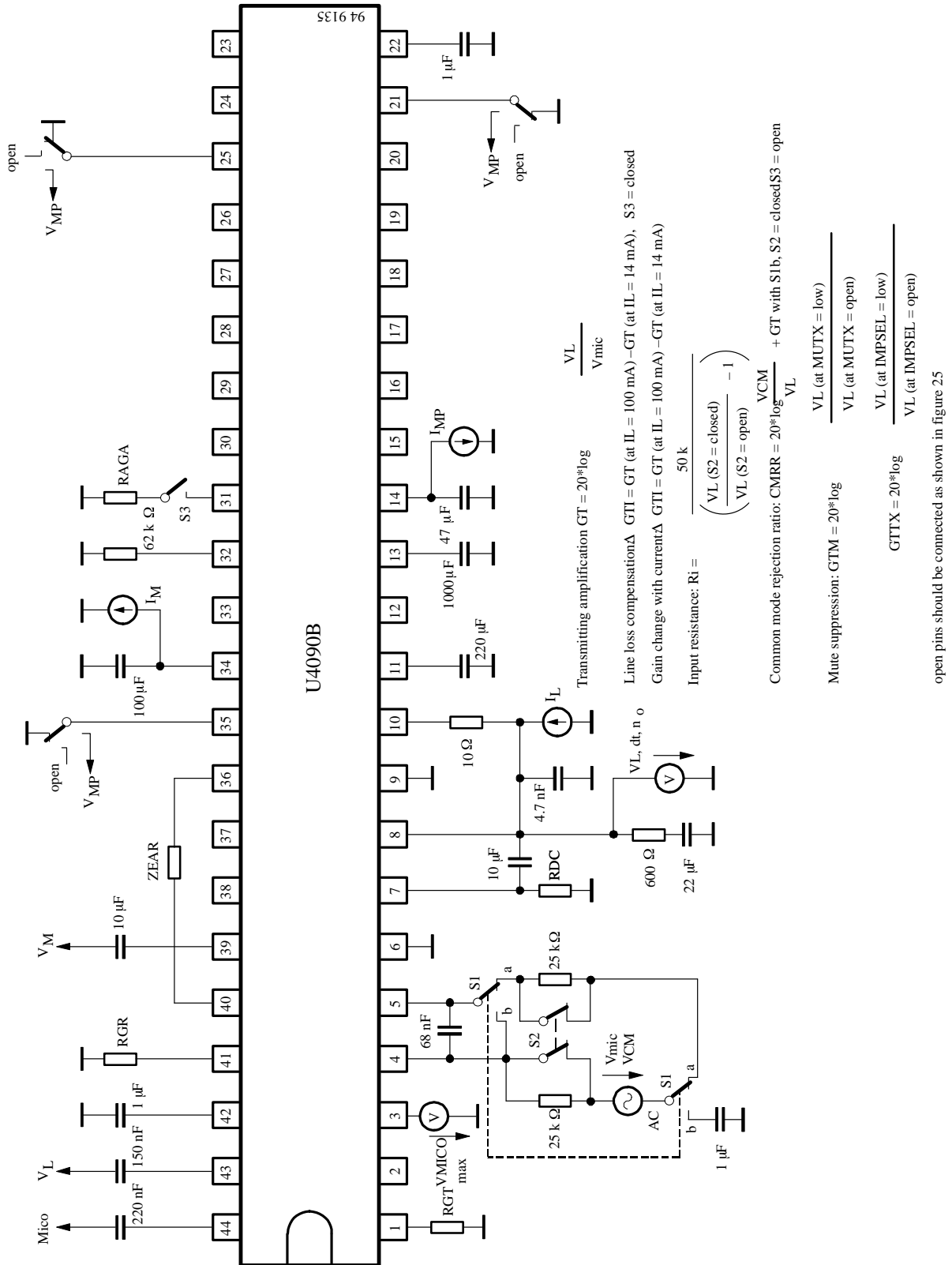

Figure 21. Transmission amplifier



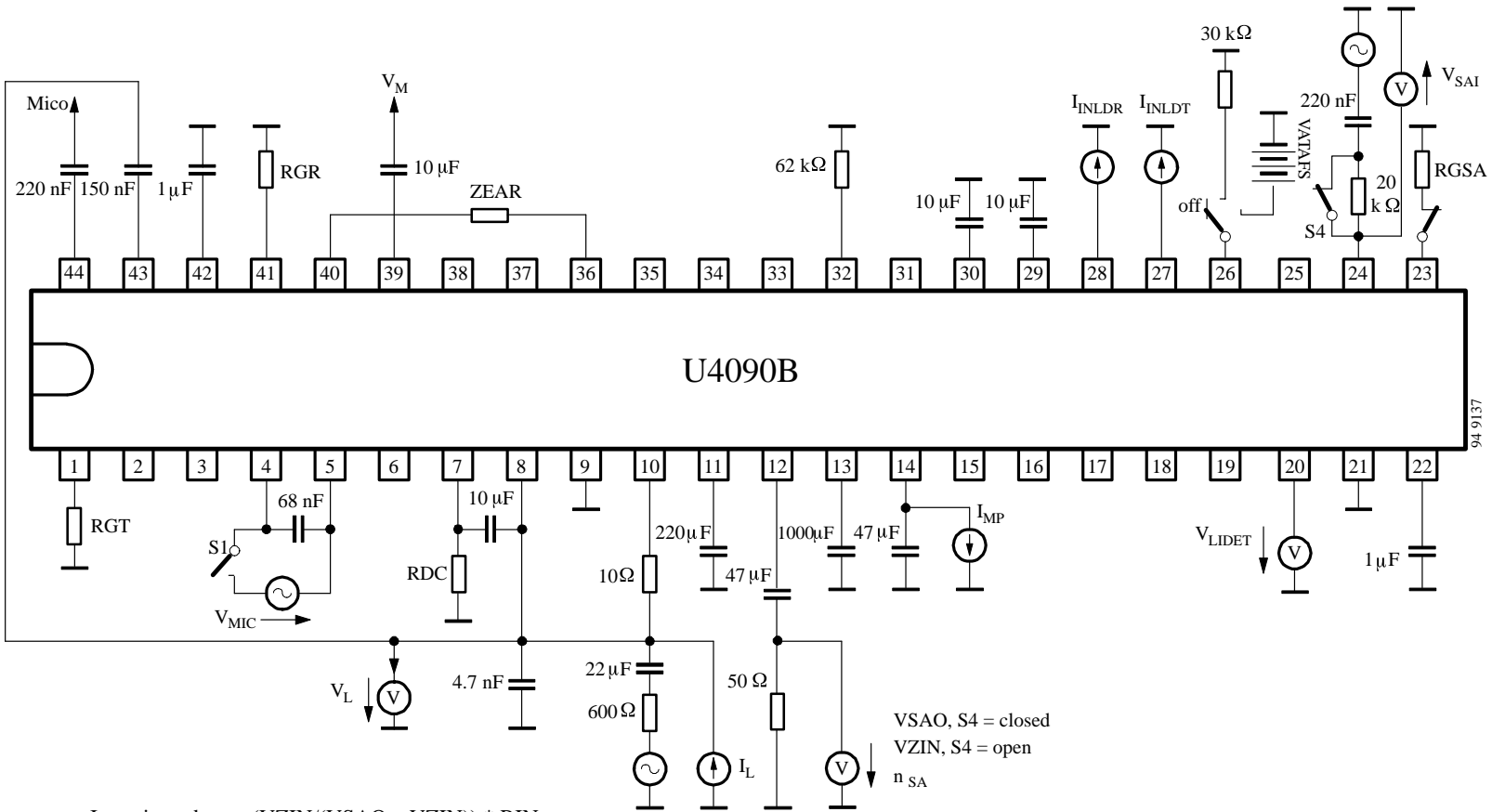

Figure 23. Speaker amplifier.

Input impedance:  $(V_{ZIN}/(V_{SAO} - V_{ZIN})) * R_{IN}$

Gain from SAI to SAO:  $20 * \log(V_{SAO} / V_{SAI})$  dB

Output power:  $PSA = \frac{V_{SAO}^2}{R_{SAO}}$

Attenuation of transmit gain: S1 = closed

Open pins should be connected as shown in figure 25



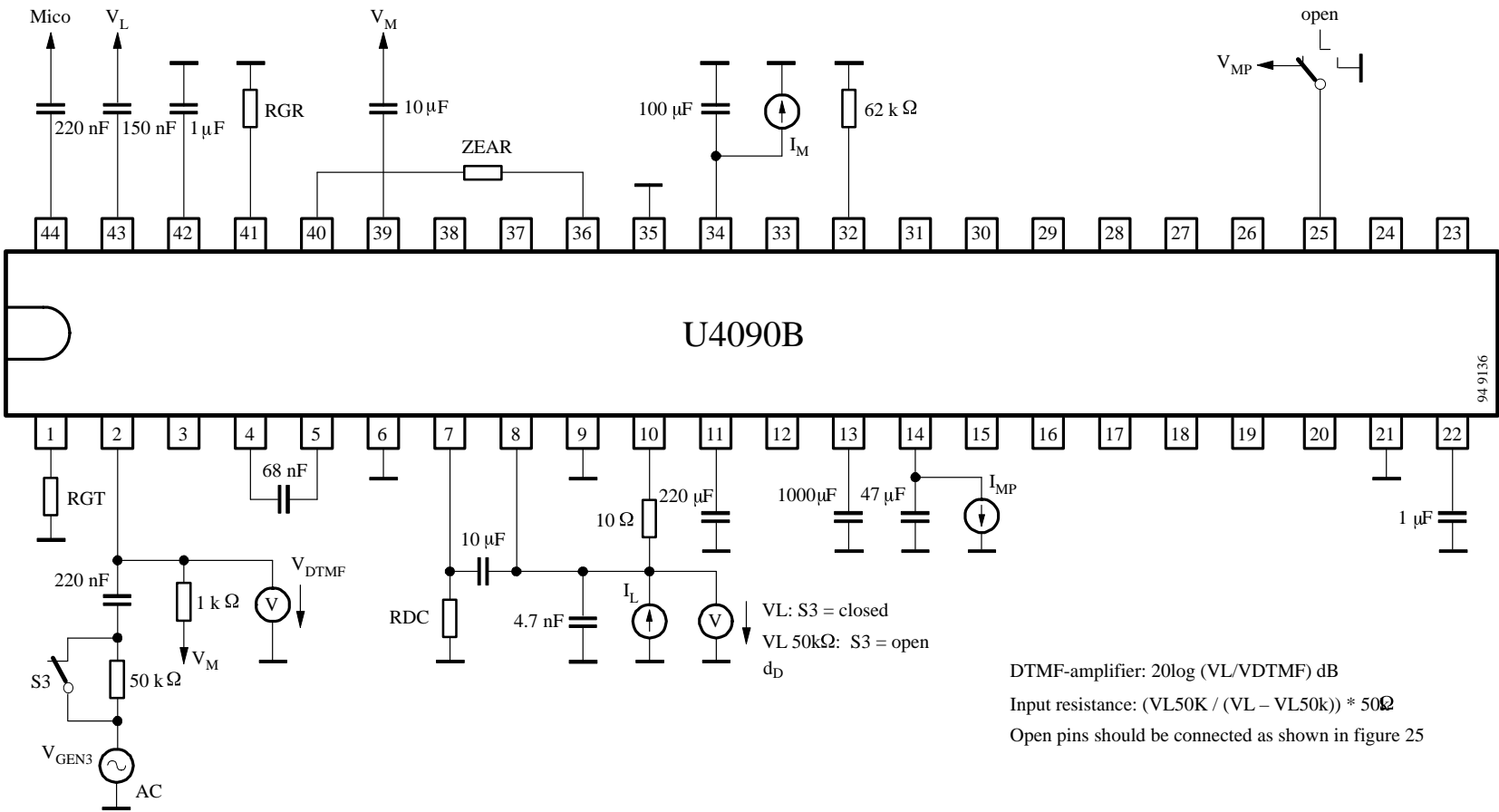

Figure 24. DTMF amplifier

- 1) Max. output power:  $PSA = \frac{V_{SAO}^2}{R_{SAO}}$  (S4 closed)
  - 2) Threshold of ringing frequency detector: detecting VRFD0, when driving VRING from 2 V to 22 V (VRINGON) and back again (VRINGOFF) (S2 = closed)
  - 3) Input impedance:  $R_{RING} = \frac{V_{RING}}{I_{RING}}$  (S3 = closed)
  - 4) Input impedance in speech mode ( $I_L > 15 \text{ mA}$ )  $R_{RINGSP} = \frac{V_{ring}}{I_{ring}}$  (S1 = closed)
  - 5) Ring detector enable: detecting VRFD0, when driving VMP from 0.7 V to 3.3 V (VMPON) and back again (VMPOFF) (S5, S3 = closed)
- Open pins should be connected as shown in figure 25

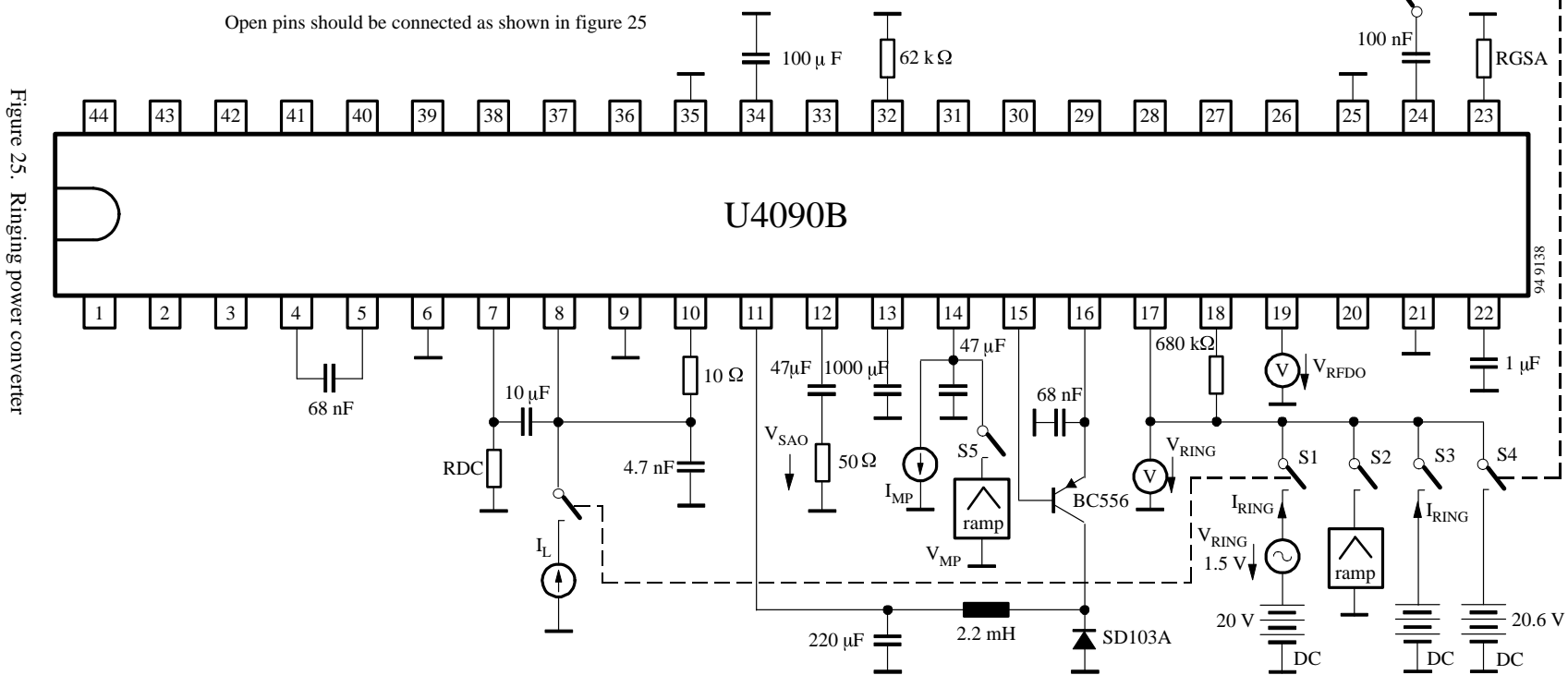

Figure 25. Ringing power converter

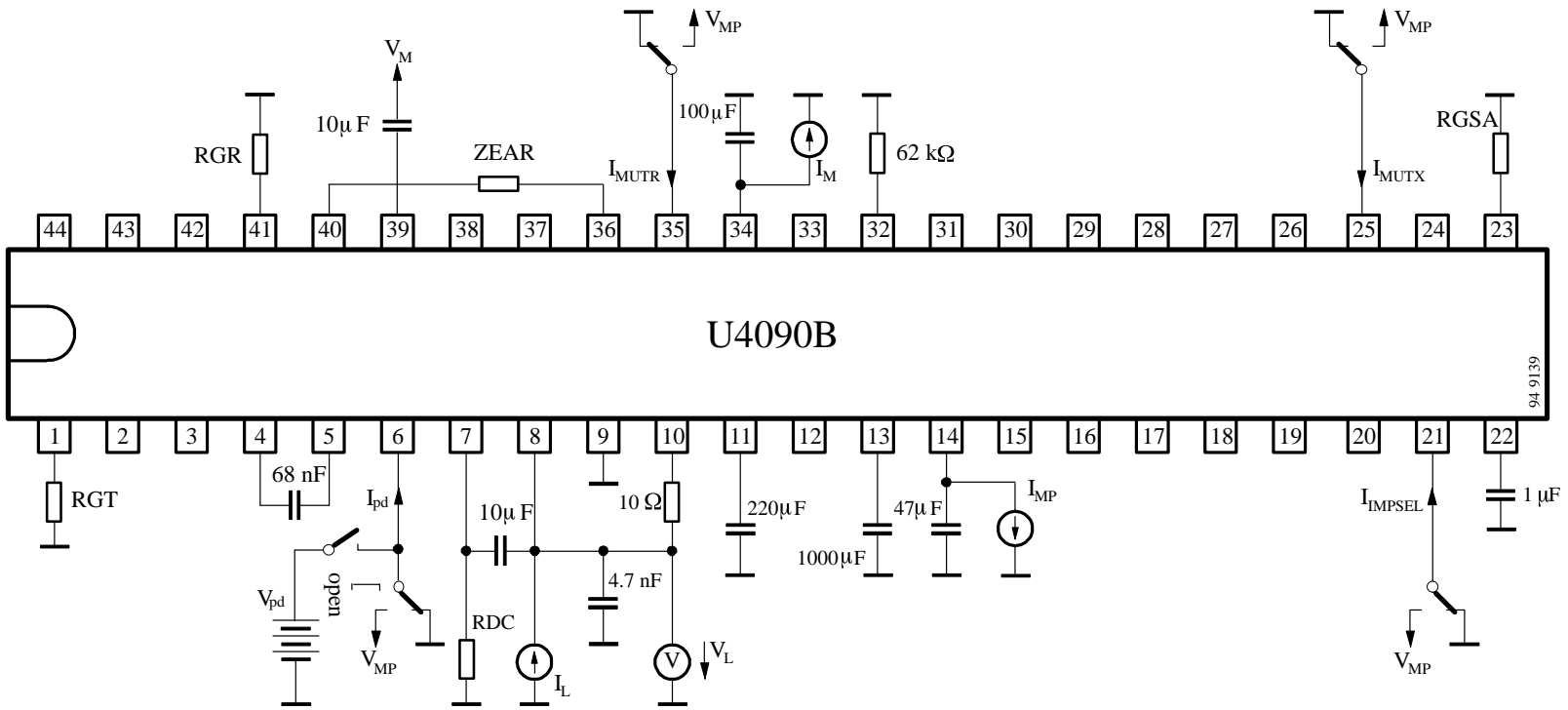

Figure 26. Input characteristics of I/O-ports

Open pins should be connected as shown in figure 25

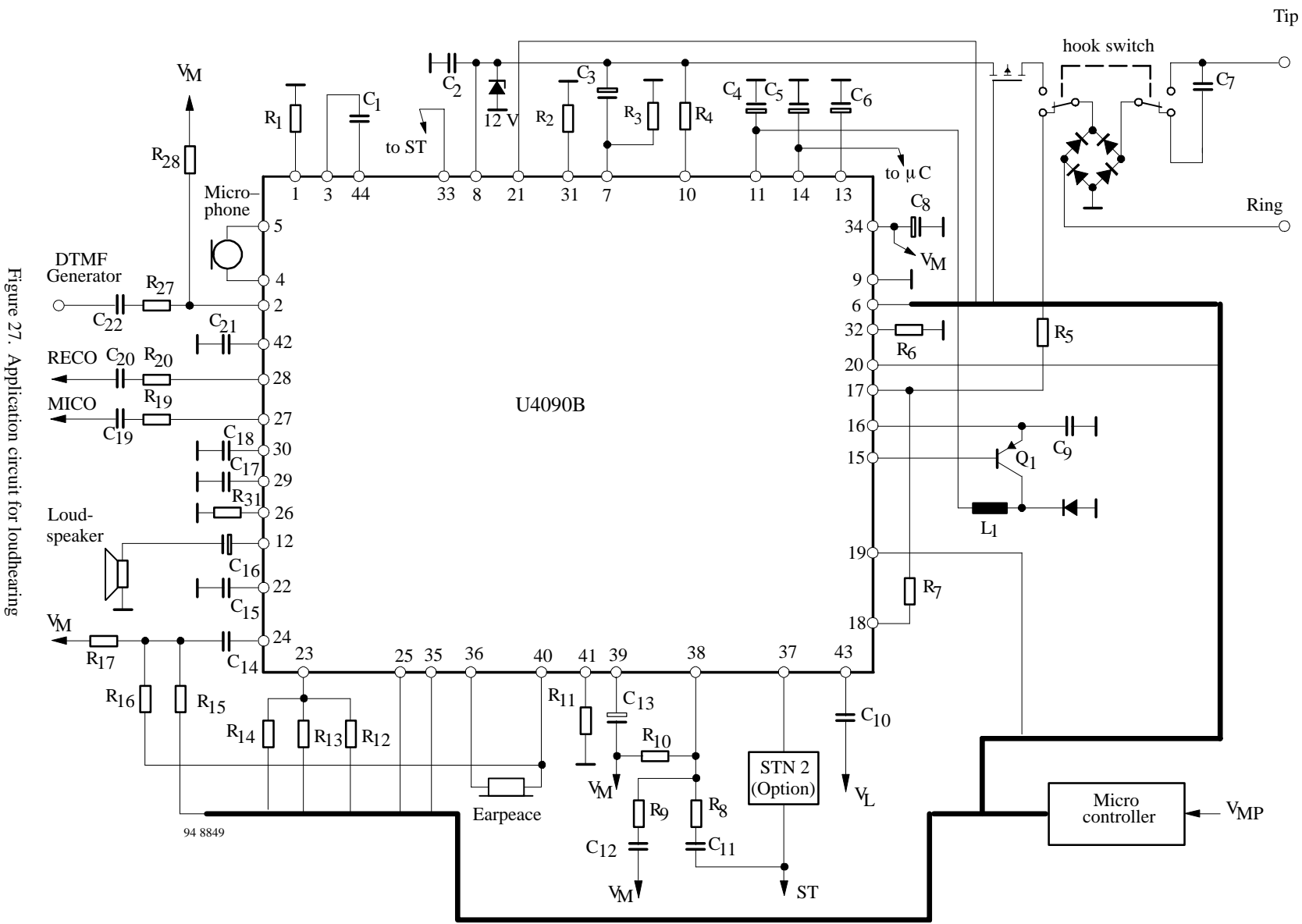

Figure 27. Application circuit for loudhearing

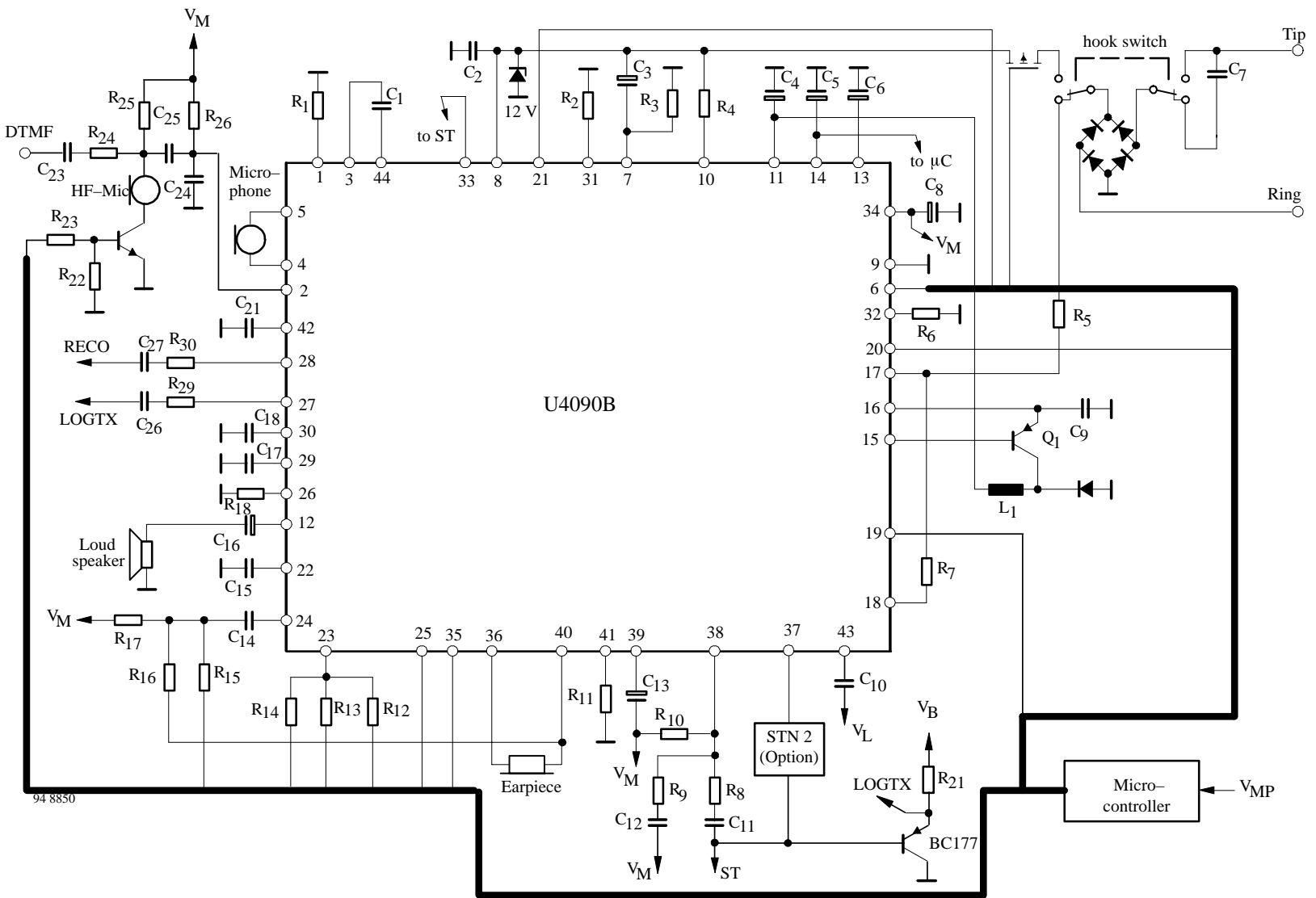

Figure 28. Application for hands-free operation

94 8850

Table 1. Typical values of external components (figures 27 and 28)

Name	Value	Name	Value	Name	Value	Name	Value
C <sub>1</sub>	100 nF	C <sub>16</sub>	47 μF	R <sub>3</sub>	>68 kΩ	R <sub>18</sub>	30 kΩ
C <sub>2</sub>	4.7 nF	C <sub>17</sub>	10 μF	R <sub>4</sub>	10 kΩ	R <sub>19</sub>	6.8 kΩ
C <sub>3</sub>	10 μF	C <sub>18</sub>	10 μF	R <sub>5</sub>	1.5 kΩ	R <sub>20</sub>	6.8 kΩ
C <sub>4</sub>	220 μF	C <sub>19</sub>	68 nF	R <sub>6</sub>	62 kΩ	R <sub>21</sub>	15 kΩ
C <sub>5</sub>	47 μF	C <sub>20</sub>	68 nF	R <sub>7</sub>	680 kΩ	R <sub>22</sub>	330 kΩ
C <sub>6</sub>	470 μF	C <sub>21</sub>	1 μF	R <sub>8</sub>	22 kΩ	R <sub>23</sub>	220 kΩ
C <sub>7</sub>	820 nF	C <sub>22</sub>	100 nF	R <sub>9</sub>	330 kΩ	R <sub>24</sub>	68 kΩ
C <sub>8</sub>	100 μF	C <sub>23</sub>	6.8 nF	R <sub>10</sub>	3 kΩ	R <sub>25</sub>	2 kΩ
C <sub>9</sub>	100 nF	C <sub>24</sub>	10 nF	R <sub>11</sub>	62 kΩ	R <sub>26</sub>	3.3 kΩ
C <sub>10</sub>	150 nF	C <sub>25</sub>	100 nF	R <sub>12</sub>	30 kΩ	R <sub>27</sub>	18 kΩ
C <sub>11</sub>	86 nF	C <sub>26</sub>	470 nF	R <sub>13</sub>	62 kΩ	R <sub>28</sub>	2 kΩ
C <sub>12</sub>	33 nF	C <sub>27</sub>	33 nF	R <sub>14</sub>	120 kΩ	R <sub>29</sub>	1 kΩ
C <sub>13</sub>	10 μF	L <sub>1</sub>	2.2 mH	R <sub>15</sub>	47 kΩ	R <sub>30</sub>	12 kΩ
C <sub>14</sub>	100 nF	R <sub>1</sub>	27 kΩ	R <sub>16</sub>	1 kΩ	R <sub>31</sub>	56 kΩ
C <sub>15</sub>	1 μF	R <sub>2</sub>	20 kΩ	R <sub>17</sub>	1.2 kΩ		

## Package Information

### Package SSO44

Dimensions in mm

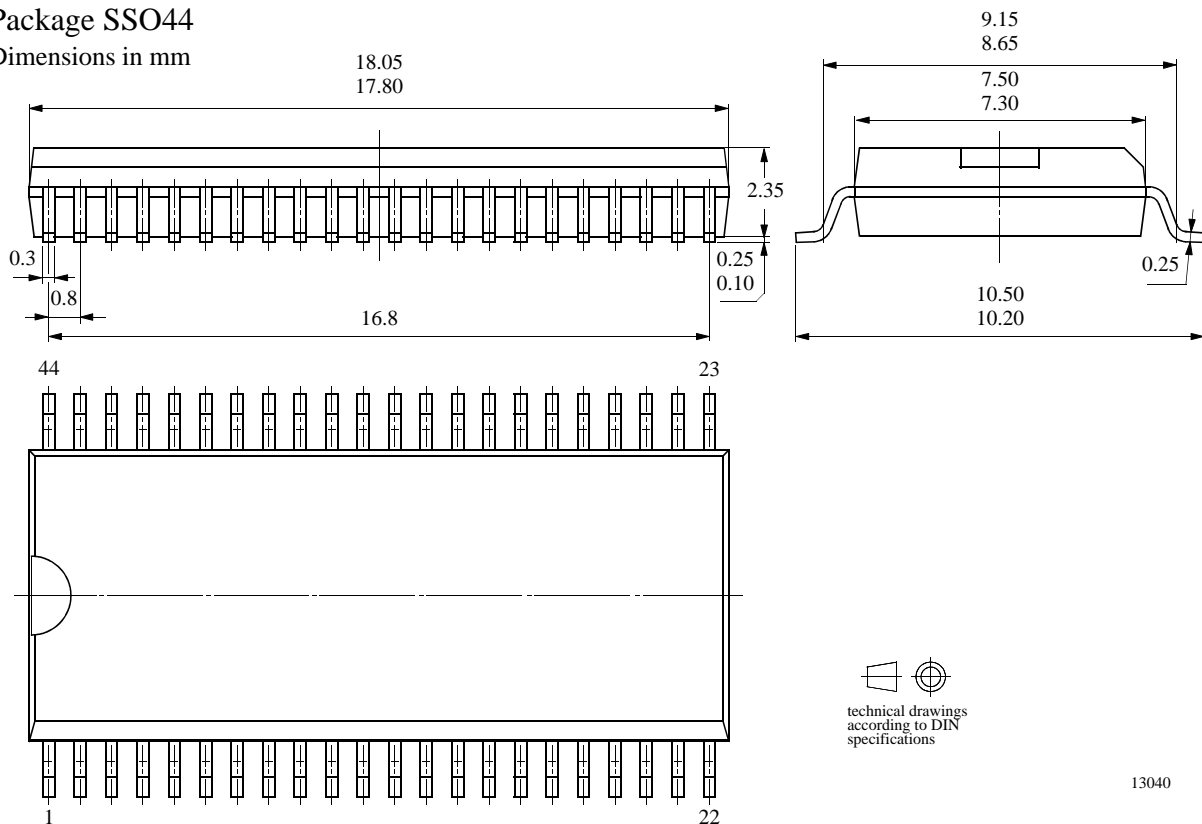

13040

---

## Ozone Depleting Substances Policy Statement

It is the policy of **TEMIC Semiconductor GmbH** to

1. Meet all present and future national and international statutory requirements.
2. Regularly and continuously improve the performance of our products, processes, distribution and operating systems with respect to their impact on the health and safety of our employees and the public, as well as their impact on the environment.

It is particular concern to control or eliminate releases of those substances into the atmosphere which are known as ozone depleting substances (ODSs).

The Montreal Protocol (1987) and its London Amendments (1990) intend to severely restrict the use of ODSs and forbid their use within the next ten years. Various national and international initiatives are pressing for an earlier ban on these substances.

**TEMIC Semiconductor GmbH** has been able to use its policy of continuous improvements to eliminate the use of ODSs listed in the following documents.

1. Annex A, B and list of transitional substances of the Montreal Protocol and the London Amendments respectively
2. Class I and II ozone depleting substances in the Clean Air Act Amendments of 1990 by the Environmental Protection Agency (EPA) in the USA
3. Council Decision 88/540/EEC and 91/690/EEC Annex A, B and C (transitional substances) respectively.

**TEMIC Semiconductor GmbH** can certify that our semiconductors are not manufactured with ozone depleting substances and do not contain such substances.

**We reserve the right to make changes to improve technical design and may do so without further notice.**

Parameters can vary in different applications. All operating parameters must be validated for each customer application by the customer. Should the buyer use TEMIC products for any unintended or unauthorized application, the buyer shall indemnify TEMIC against all claims, costs, damages, and expenses, arising out of, directly or indirectly, any claim of personal damage, injury or death associated with such unintended or unauthorized use.

TEMIC Semiconductor GmbH, P.O.B. 3535, D-74025 Heilbronn, Germany  
Telephone: 49 (0)7131 67 2831, Fax number: 49 (0)7131 67 2423