

5821 AND 5822

BiMOS II 8-BIT SERIAL-INPUT, LATCHED DRIVERS

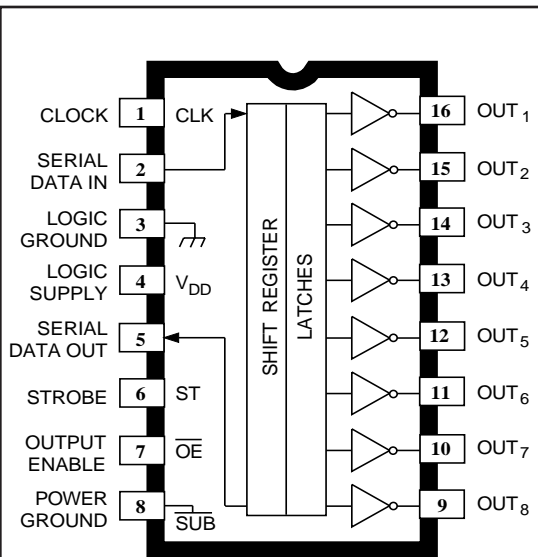

Dwg. PP-026A

Note the DIP package and the SOIC package are electrically identical and share common terminal number assignments.

ABSOLUTE MAXIMUM RATINGS at 25°C Free-Air Temperature

Output Voltage, V_{OUT}	
UCN5821A & UCN5821LW.....	50 V
UCN5822A & UCN5822LW.....	80 V
Logic Supply Voltage, V_{DD}	15 V
Input Voltage Range,	
V_{IN}	-0.3 V to $V_{DD} + 0.3 V$
Continuous Output Current,	
I_{OUT}	500 mA
Package Power Dissipation, P_D	
Package Code 'A'	2.1 W
Package Code 'LW'	1.5 W
Operating Temperature Range,	
T_A	-20°C to +85°C
Storage Temperature Range,	
T_S	-55°C to +150°C

Caution: CMOS devices have input static protection but are susceptible to damage when exposed to extremely high static electrical charges.

A merged combination of bipolar and MOS technology gives these devices an interface flexibility beyond the reach of standard logic buffers and power driver arrays. The UCN5821A, UCN5821LW, UCN5822A, and UCN5822LW each have an eight-bit CMOS shift register and CMOS control circuitry, eight CMOS data latches, and eight bipolar current-sinking Darlington output drivers. The UCN5821A/LW and UCN5822A/LW are identical except for rated output voltage.

BiMOS II devices have much higher data-input rates than the original BiMOS circuits. With a 5 V logic supply, they will typically operate at better than 5 MHz. With a 12 V supply, significantly higher speeds are obtained. The CMOS inputs are compatible with standard CMOS and NMOS logic levels. TTL circuits may require the use of appropriate pull-up resistors. By using the serial data output, the drivers can be cascaded for interface applications requiring additional drive lines.

The UCN5821/22A are furnished in a standard 16-pin plastic DIP; the UCN5821/22LW are in a 16-lead wide-body SOIC for surface-mount applications. The UCN5821A and UCN5822A are also available for operation from -40°C to +85°C. To order, change the prefix from 'UCN' to 'UCQ'.

FEATURES

- To 3.3 MHz Data Input Rate
- CMOS, NMOS, TTL Compatible
- Internal Pull-Down Resistors
- Low-Power CMOS Logic & Latches
- High-Voltage Current-Sink Outputs
- Automotive Capable

Always order by complete part number, e.g., **UCN5821A**.

5821 AND 5822 8-BIT SERIAL-INPUT, LATCHED DRIVERS

TYPICAL INPUT CIRCUITS

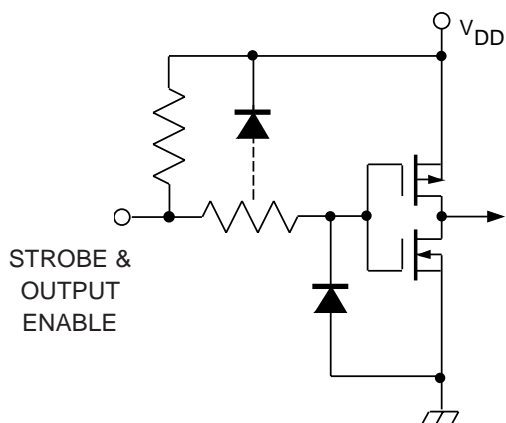

Dwg. EP-010-3

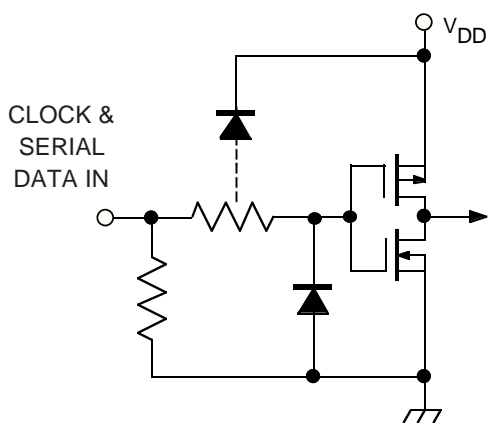

Dwg. EP-010-4A

TYPICAL OUTPUT DRIVER

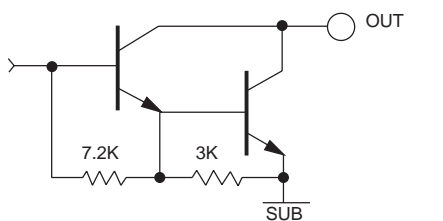

Dwg. No. A-14,314

FUNCTIONAL BLOCK DIAGRAM

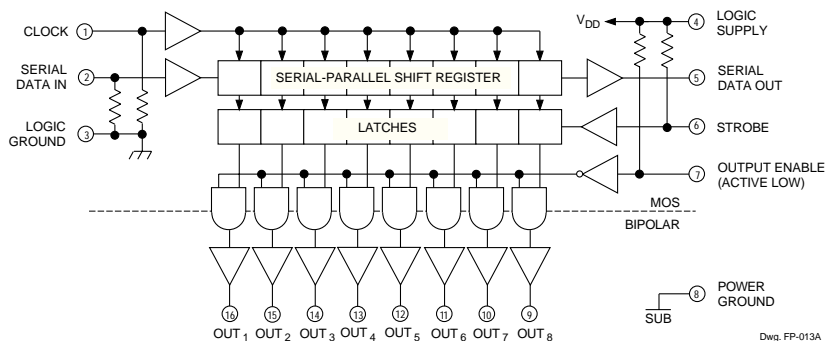

Dwg. FP-013A

NOTE — There is an indeterminate resistance between logic ground and power ground. For proper operation, these terminals must be externally connected together.

Number of Outputs ON UCN5821A Max. Allowable Duty Cycle
($I_{OUT} = 200 \text{ mA}$
 $V_{DD} = 12 \text{ V}$) at Ambient Temperature of

	at Ambient Temperature of				
	25°C	40°C	50°C	60°C	70°C
8	90%	79%	72%	65%	57%
7	100%	90%	82%	74%	65%
6	100%	100%	96%	86%	76%
5	100%	100%	100%	100%	91%
4	100%	100%	100%	100%	100%
3	100%	100%	100%	100%	100%
2	100%	100%	100%	100%	100%
1	100%	100%	100%	100%	100%

Number of Outputs ON UCN5821LW Max. Allowable Duty Cycle
($I_{OUT} = 200 \text{ mA}$
 $V_{DD} = 12 \text{ V}$) at Ambient Temperature of

	at Ambient Temperature of				
	25°C	40°C	50°C	60°C	70°C
8	67%	59%	54%	49%	43%
7	77%	68%	62%	56%	49%
6	90%	79%	72%	65%	57%
5	100%	95%	86%	78%	68%
4	100%	100%	100%	98%	86%
3	100%	100%	100%	100%	100%
2	100%	100%	100%	100%	100%
1	100%	100%	100%	100%	100%

5821 AND 5822

8-BIT SERIAL-INPUT, LATCHED DRIVERS

ELECTRICAL CHARACTERISTICS at $T_A = +25^\circ\text{C}$, $V_{DD} = 5\text{ V}$, (unless otherwise specified).

Characteristic	Symbol	Test Conditions	Limits		
			Min.	Max.	Units
Output Leakage Current	I_{CEX}	UCN5821A/LW, $V_{OUT} = 50\text{ V}$	—	50	μA
		UCN5822A/LW, $V_{OUT} = 80\text{ V}$	—	50	μA
		UCN5821A/LW, $V_{OUT} = 50\text{ V}$, $T_A = +70^\circ\text{C}$	—	100	μA
		UCN5822A/LW, $V_{OUT} = 80\text{ V}$, $T_A = +70^\circ\text{C}$	—	100	μA
Collector-Emitter Saturation Voltage	$V_{CE(SAT)}$	$I_{OUT} = 100\text{ mA}$	—	1.1	V
		$I_{OUT} = 200\text{ mA}$	—	1.3	V
		$I_{OUT} = 350\text{ mA}$, $V_{DD} = 7.0\text{ V}$	—	1.6	V
Input Voltage	$V_{IN(0)}$		—	0.8	V
	$V_{IN(1)}$	$V_{DD} = 12\text{ V}$	10.5	—	V
		$V_{DD} = 5.0\text{ V}$	3.5	—	V
Input Resistance	r_{IN}	$V_{DD} = 12\text{ V}$	50	—	$\text{k}\Omega$
		$V_{DD} = 5.0\text{ V}$	50	—	$\text{k}\Omega$
Supply Current	$I_{DD(ON)}$	One Driver ON, $V_{DD} = 12\text{ V}$	—	4.5	mA
		One Driver ON, $V_{DD} = 10\text{ V}$	—	3.9	mA
		One Driver ON, $V_{DD} = 5.0\text{ V}$	—	2.4	mA
	$I_{DD(OFF)}$	$V_{DD} = 5.0\text{ V}$, All Drivers OFF, All Inputs = 0 V	—	1.6	mA
		$V_{DD} = 12\text{ V}$, All Drivers OFF, All Inputs = 0 V	—	2.9	mA

5821 AND 5822 8-BIT SERIAL-INPUT, LATCHED DRIVERS

UCN5821A and UCN5822A Dimensions in Inches (controlling dimensions)

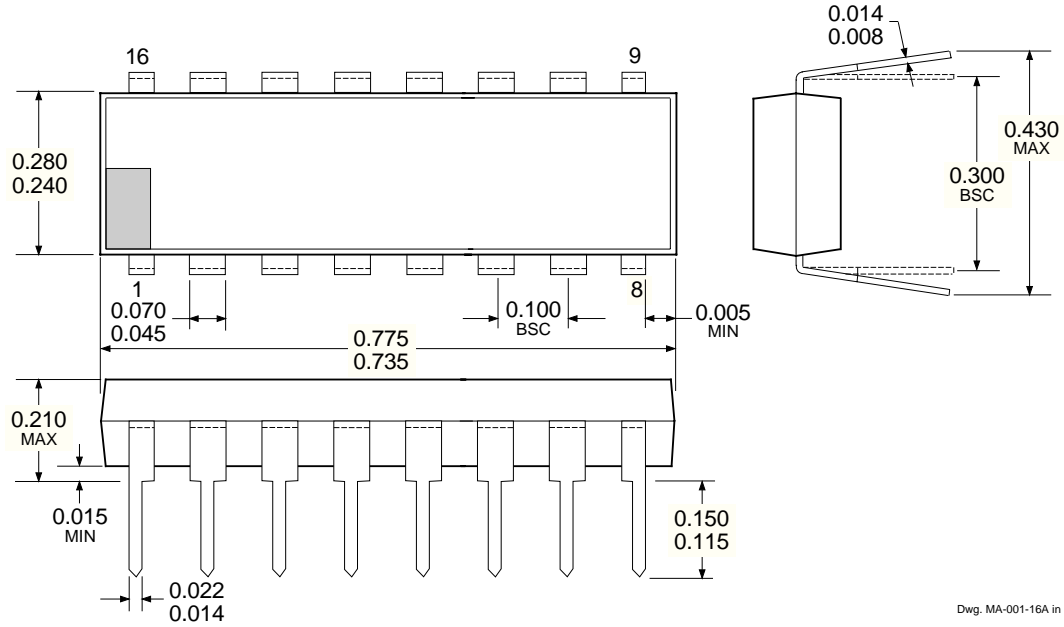

Dimensions in Millimeters (for reference only)

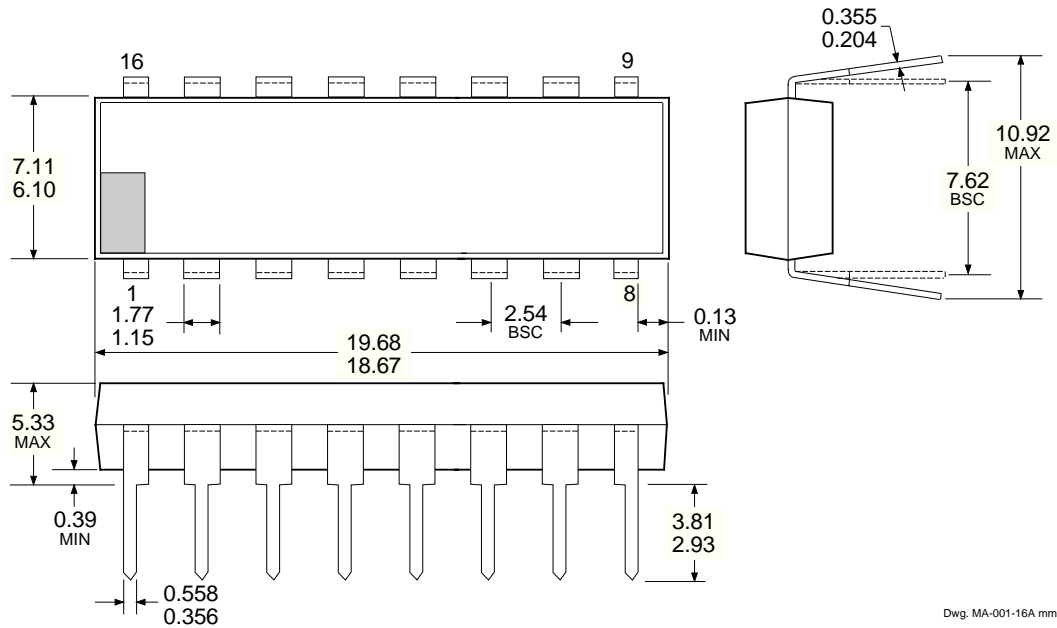

- NOTES:
1. Lead thickness is measured at seating plane or below.
 2. Lead spacing tolerance is non-cumulative.
 3. Exact body and lead configuration at vendor's option within limits shown.

5821 AND 5822 8-BIT SERIAL-INPUT, LATCHED DRIVERS

UCN5821LW and UCN5822LW Dimensions in Inches (for reference only)

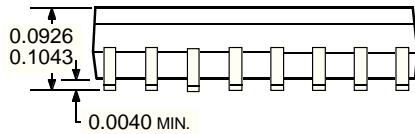
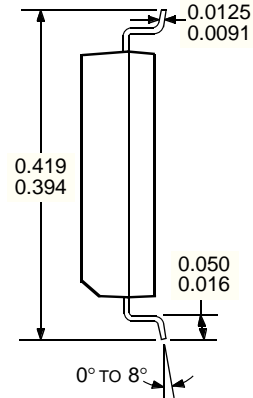
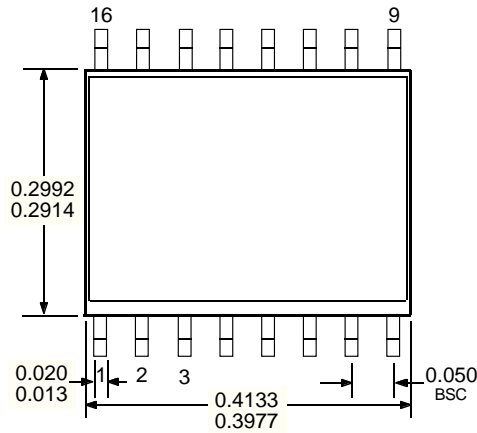

Dwg. MA-008-16A in

Dimensions in Millimeters (controlling dimensions)

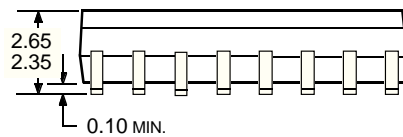
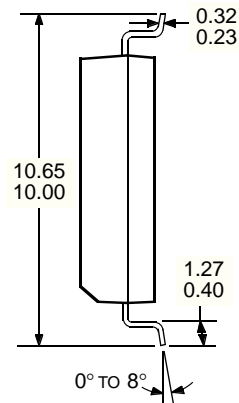
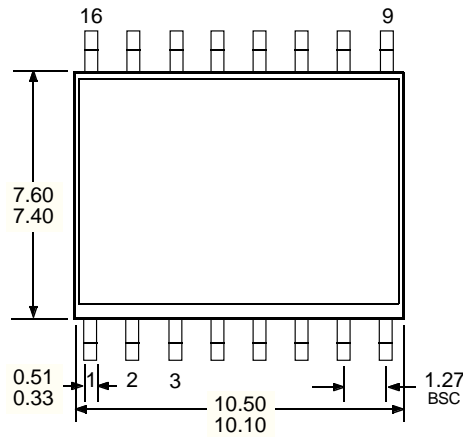

Dwg. MA-008-16A mm

- NOTES: 1. Lead spacing tolerance is non-cumulative.
2. Exact body and lead configuration at vendor's option within limits shown.

5821 AND 5822
8-BIT SERIAL-INPUT,
LATCHED DRIVERS

This page intentionally left blank

5821 AND 5822
8-BIT SERIAL-INPUT,
LATCHED DRIVERS

BiMOS II (Series 5800) & DABiC IV (Series 6800)
INTELLIGENT POWER INTERFACE DRIVERS
SELECTION GUIDE

Function	Output Ratings *		Part Number †
SERIAL-INPUT LATCHED DRIVERS			
8-Bit (saturated drivers)	-120 mA	50 V‡	5895
8-Bit	350 mA	50 V	5821
8-Bit	350 mA	80 V	5822
8-Bit	350 mA	50 V‡	5841
8-Bit	350 mA	80 V‡	5842
9-Bit	1.6 A	50 V	5829
10-Bit (active pull-downs)	-25 mA	60 V	5810-F and 6809/10
12-Bit (active pull-downs)	-25 mA	60 V	5811 and 6811
20-Bit (active pull-downs)	-25 mA	60 V	5812-F and 6812
32-Bit (active pull-downs)	-25 mA	60 V	5818-F and 6818
32-Bit	100 mA	30 V	5833
32-Bit (saturated drivers)	100 mA	40 V	5832
PARALLEL-INPUT LATCHED DRIVERS			
4-Bit	350 mA	50 V‡	5800
8-Bit	-25 mA	60 V	5815
8-Bit	350 mA	50 V‡	5801
SPECIAL-PURPOSE FUNCTIONS			
Unipolar Stepper Motor Translator/Driver	1.25 A	50 V‡	5804
Addressable 28-Line Decoder/Driver	450 mA	30 V	6817

* Current is maximum specified test condition, voltage is maximum rating. See specification for sustaining voltage limits. Negative current is defined as coming out of (sourcing) the output.

† Complete part number includes additional characters to indicate operating temperature range and package style.

‡ Internal transient-suppression diodes included for inductive-load protection.

Allegro MicroSystems, Inc. reserves the right to make, from time to time, such departures from the detail specifications as may be required to permit improvements in the design of its products.

The information included herein is believed to be accurate and reliable. However, Allegro MicroSystems, Inc. assumes no responsibility for its use; nor for any infringements of patents or other rights of third parties which may result from its use.

