

20-S3-F443FX -092002

USER'S MANUAL

S3F443FX

**16/32-Bit RISC
Microcontroller
Revision 0**



1

PRODUCT OVERVIEW

INTRODUCTION

SAMSUNG S3F443FX 16/32-bit RISC micro-controller is a cost-effective and high-performance solution for HDD and general purpose applications.

An outstanding feature of the S3F443FX is its CPU core, a 16/32-bit RISC processor (ARM7TDMI) designed by Advanced RISC Machines, Ltd. The ARM7TDMI core is a low-power, general-purpose, microprocessor macro-cell which was developed for the use in application-specific and customer-specific integrated circuits. Its simple, elegant, and fully static design is particularly suitable for cost-sensitive and power-sensitive applications.

The S3F443FX has been developed by using the ARM7TDMI core, CMOS standard cell, and data path compiler. The S3F443FX has been designed to support only Big Endian. Most of the on-chip function blocks have been designed by using a HDL synthesizer. The S3F443FX has been fully verified in SAMSUNG ASIC test environment including internal Qualification Assurance Process.

By providing a complete set of common system peripherals, the S3F443FX can minimize the overall system costs and eliminate the need to configure additional components, externally.

The integrated on-chip functions which are described in this document include:

- Memory system manager: 3 external memory banks. (If the internal flash ROM is not used for a boot code, nCS0 will be used for a boot ROM)
- Built-in 256Kbyte (64K × 32-bit) Flash memory
- 8K-bytes (2K × 32-bit) internal SRAM for stack, data memory, and/or code memory
- One channel UART
- Six 16-bit internal timers with 8-bit pre-scaler and input Capture function
- Power down mode: STOP and IDLE modes
- One 8-bit basic timer and 3-bit watch-dog timer
- Interrupt controller (Total of 21 interrupt sources including 3 external sources)
- Sixteen programmable I/O ports
- One 8-Bit PWM
- 64-pin LQFP

FEATURES

Architecture

- Completely integrated micro-controller for embedded applications
- Big Endian only supported
- Fully 16/32-bit RISC architecture
- Efficient and powerful ARM7TDMI CPU core
- Cost effective JTAG-based debugging solution

Memory

- 8-bit external bus support for one ROM bank and two external memory banks
- Programmable memory access times (from 0 to 7 wait cycles)
- 8-Kbyte SRAM (for stack, data memory, and/or code memory)
- Built-in 256-Kbyte Flash memory (for data and/or code memory)

UART

- One UART channel with interrupt-based operation
- Programmable baud rates
- Supports asynchronous serial data transmit/receive operations with 5-bit, 6-bit, 7-bit, 8-bit data per frame

16-bit Timers/Counters with Capture Function (T0, T1, T2, T3, T4 and T5)

- Six programmable 16-bit timer/counters
- Interval, capture, or match & overflow mode operations
- EXTCLK or TIN (Timer Input Capture Signal) can be the clock source for the timer.
- TIN is shared by all timers.

PWM

- One-8 bit PWM
- Clock source is driven from EXTCLK signal source divided by 1/1 or by 1/2
- PWM signal out

Basic Timer and Watch-dog Timer

- 8-bit counter (Basic Timer) + 3-bit counter (Watch-dog Timer).
- Overflow signal from the 8-bit counter can generate a basic timer interrupt and can be the input clock for the 3-bit counter.
- Overflow signal from the 3-bit counter resets the system.

I/O Ports

- 16 programmable I/O ports (7 dedicated I/O pins only)
- Each port pin can be configured individually as input, output, or functional pin

Interrupts

- 21 interrupt sources including 3 external Interrupt sources.
- H/W interrupt priority logic and vector generation
- Normal or fast interrupt mode (IRQ, FIQ)

Power down mode

- IDLE and STOP modes
- Division of system clock to reduce the power (1/1, 1/2, 1/8, 1/16 and 1/1024)

Operating Voltage Range

- Core: 1.8V ,I/O: 2.7–3.6V

Operating Frequency Range

- up to 80MHz (CPU core, SRAM, and Peripherals)
- up to 40MHz (Flash ROM)

Package Type

- 64-pin LQFP

BLOCK DIAGRAM

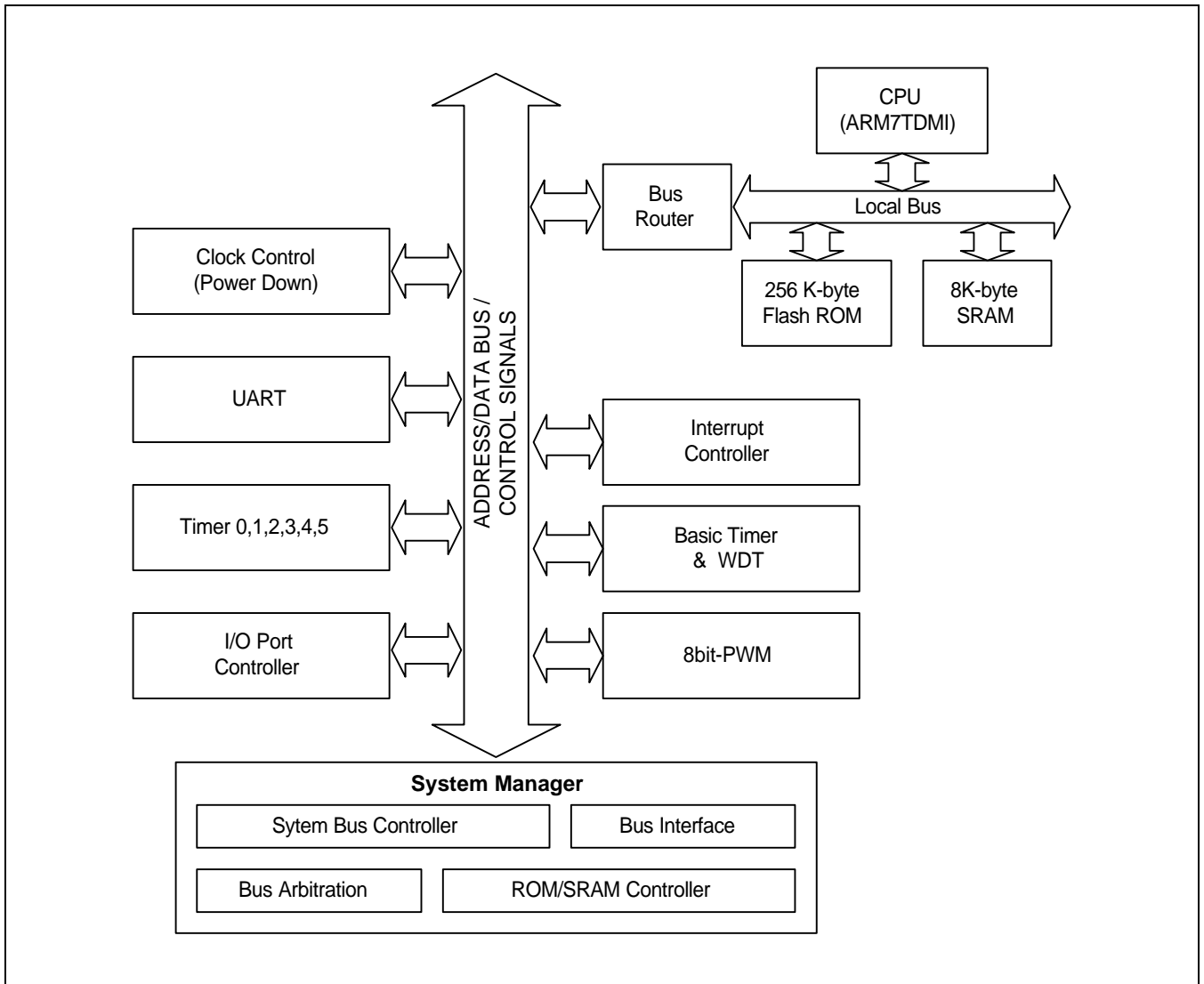

Figure 1-1. S3F443FX Block Diagram

PIN ASSIGNMENTS

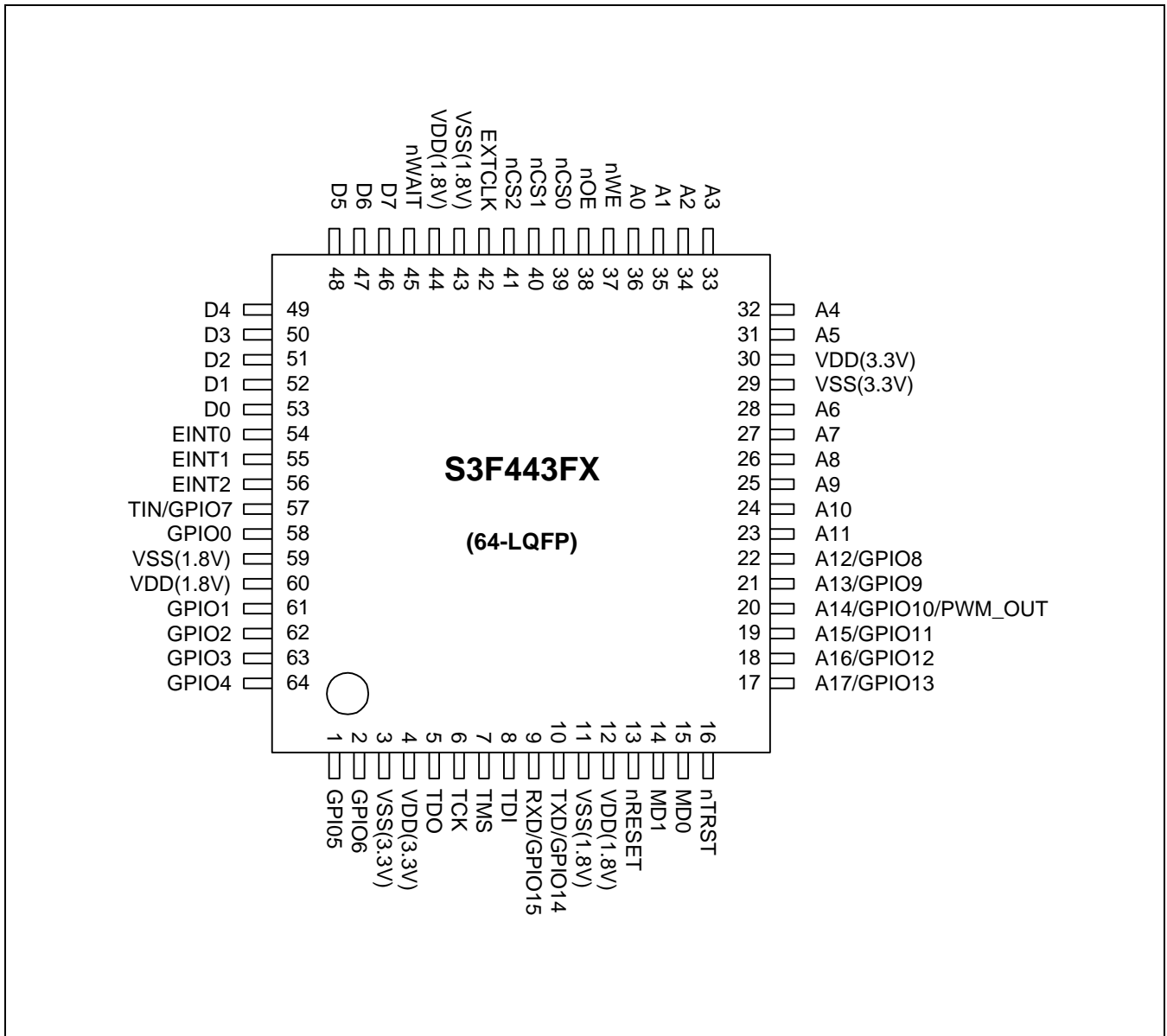

Figure 1-2. S3F443FX Pin Assignments (64-LQFP)

SIGNAL DESCRIPTIONS

Table 1-1. S3F443FX Signal Descriptions (64-pin LQFP)

Signal	Pin #	I/O Pin Type	Description
TDO	5	O	TDO (TAP Controller Data Output) is the serial output for the JTAG port
TCK	6	IU	TCK (TAP Controller Clock) provides the clock input for the JTAG logic. A 100K pull-up resistor is connected to the TCK pin internally.
TMS	7	IU	TMS (TAP Controller Mode Select) controls the sequence of the TAP controller state diagram. A 100K pull-up resistor is connected to the TMS pin internally.
TDI	8	IU	TDI (TAP Controller Data Input) is the serial input for the JTAG port. A 100K pull-up resistor is connected to the TDI pin internally.
nTRST	16	IU	nTRST (TAP Controller Reset) resets the TAP controller at start. A 100K pull-up resistor is connected to the nTRST pin internally. If the debugger (Black ICE) is not used, nTRST pin should be L level or low active pulse should be applied before running the CPU. For example, nRESET signal can be tied with the nTRST.
MD[1:0]	14,15	I	00: Normal mode (In-ROM mode). The nCS0 may be used for an external device. (MDS can be used.) 01: External ROM mode. The nCS0 will be used for boot code instead of the internal FLASH ROM. (MDS can be used.) 10: Optional MDS mode for ICE. (External ROM mode is selected) 11: Test mode for Internal Flash memory, which is used only a flash writer equipment.
nRESET	13	IUS	nRESET is the global reset input for the S3F443FX. For a safe system reset, nRESET should be held at Low level for at least 150us.
A17/GPIO13	17	IOPD	A17: Address line A17 GPIO[13]: Programmable I/O port 13 for push-pull input or output.
A16/GPIO12	18	IOPD	A16: Address line A16 GPIO[12]: Programmable I/O port 12 for push-pull input or output.
A15/GPIO11	19	IOPD	A15: Address line A15 GPIO[11]: Programmable I/O port 11 for push-pull input or output.
A14/GPIO10/ PWM_OUT	20	IOPD	A14: Address line A14 GPIO[10]: Programmable I/O port 10 for push-pull input or output. PWM_OUT: PWM signal out
A13/GPIO9	21	IOPD	A13: Address line A13 GPIO[9]: Programmable I/O port 9 for push-pull input or output.
A12/GPIO8	22	IOPD	A12: Address line A12 GPIO[8]: Programmable I/O port 8 for push-pull input or output.
A[11:0]	23-28, 31-36	O	Address lines A11–A0

Table 1-1. S3F443FX Signal Descriptions (64-pin LQFP) (Continued)

Signal	Pin #	I/O Pin Type	Description
nWE	37	O	nWE (Write Enable) indicates that the current bus cycle is a write cycle.
nOE	38	O	nOE (Output Enable) indicates that the current bus cycle is a read cycle.
nWAIT	45	IU	nWAIT requests to prolong a current bus cycle. As long as nWAIT is L, the current bus cycle cannot be completed.
nCS0	39	O	nCS0 (Chip Select 0) can be activated when the issued address for memory access is within the address region 0x0–0x3FFFF and MD[1:0] is configured as an external ROM mode.
nCS1	40	O	nCS1 (Chip Select 1) can be activated when the issued address for memory access is within the address region 0x800000–0x83FFFF.
nCS2	41	O	nCS2 (Chip Select 2) can be activated when the issued address for memory access is within the address region 0xC00000–0xC3FFFF.
D[7:0]	46-53	IOPD	D[7:0] (Bi-directional Data Bus) inputs data during memory read and outputs data during memory write.
EXTCLK	42	IS	External clock source.
EINT[2:0]	54-56	IOPUSE	External interrupt inputs 2–0.
TIN/GPIO7	57	IOPUS	TIN: Timer capture input GPIO[7]: Programmable I/O port 7 for push-pull input or output.
GPIO[6:0]	58,61– 64,1-2	IOPU	GPIO[6:0]: Programmable I/O port 6–0 for push-pull input/output.
RXD/GPIO15	9	IOPUS	RXD: Rx data input for the UART GPIO[15]: Programmable I/O port 15 for push-pull input or output.
TXD/GPIO14	10	IOPUS	TXD: Tx data output for the UART GPIO[14]: Programmable I/O port 14 for push-pull input or output.
V _{DD} (3.3V)	4,30		3.3 Volt for Peripheral Block
V _{DD} (1.8V)	12,44, 60	–	1.8 Volt for Core Block
V _{SS} (3.3V)	3,29		3.3 Volt for Peripheral Block
V _{SS} (1.8V)	11,43, 59	–	1.8 Volt for Core Block

I/O PIN TYPES**Table 1-2. S3F443FX I/O Pin Types**

I/O Type	Descriptions
IOPUS	Schmitt-trigger input/output pin with programmable pull-up resistor
IOPUSE	Schmitt-trigger input/output pin with programmable pull-up resistor and edge detection
IOPD	Input/output pin with programmable pull-down resistor
IOPU	Input/output pin with programmable pull-up resistor
O	Output pin
IUS	Schmitt-trigger Input pin with pull-up resistor
I	Input pin
IU	Input pin with pull-up resistor
IS	Schmitt-trigger input pin
A	A pin for analog signal

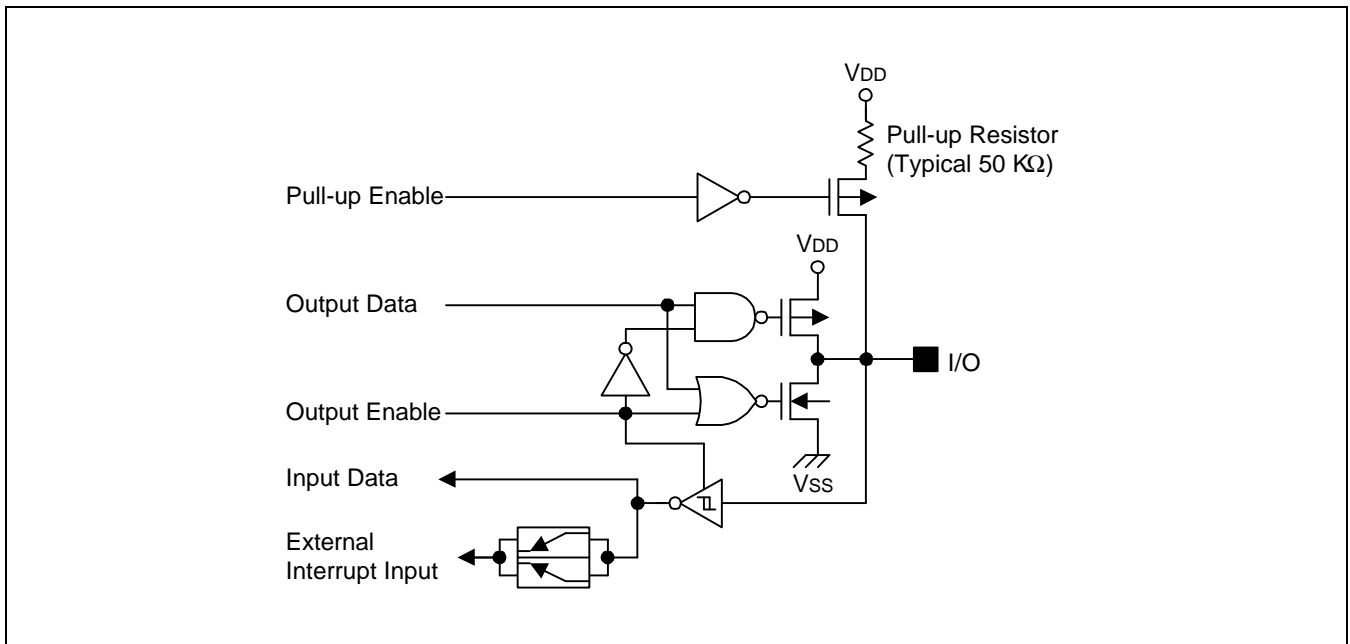

Figure 1-3. IOPUSE (Schmitt Input/Output Pin with Programmable Pull-up Resistor and Edge Detection)

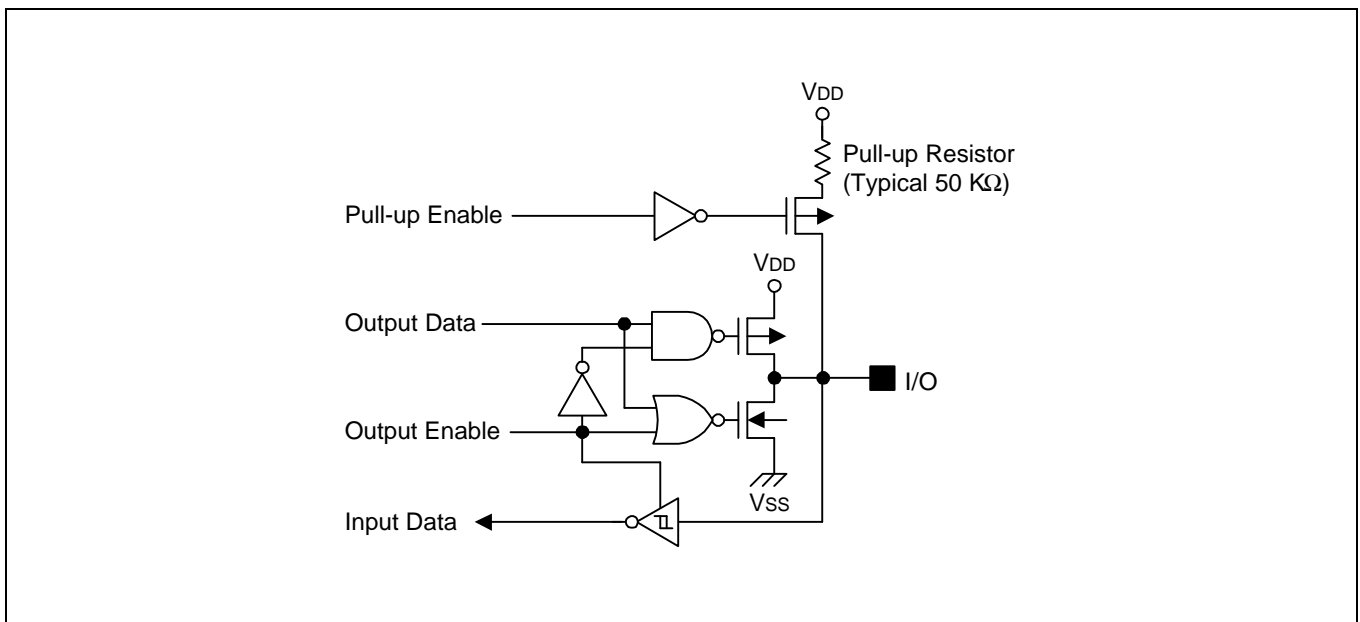

Figure 1-4. IOPUS (Schmitt Input/Output Pin with Programmable Pull-up Resistor)

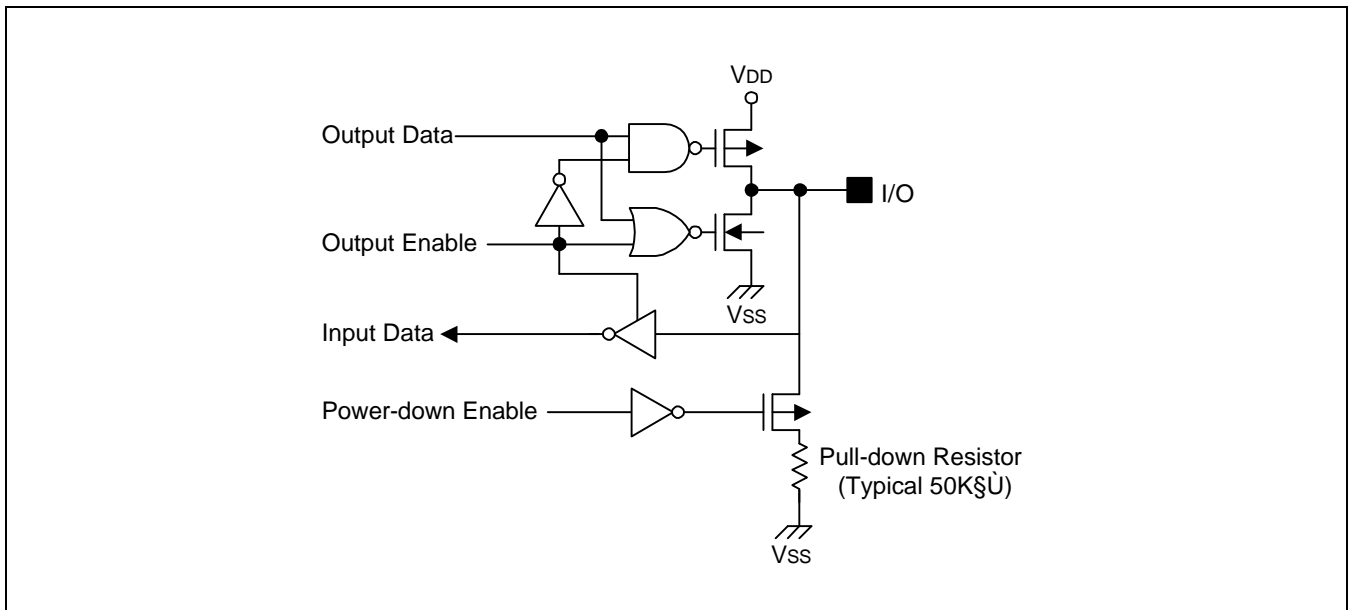

Figure 1-5. IOPD (Input/Output Pin with Programmable Pull-down Resistor)

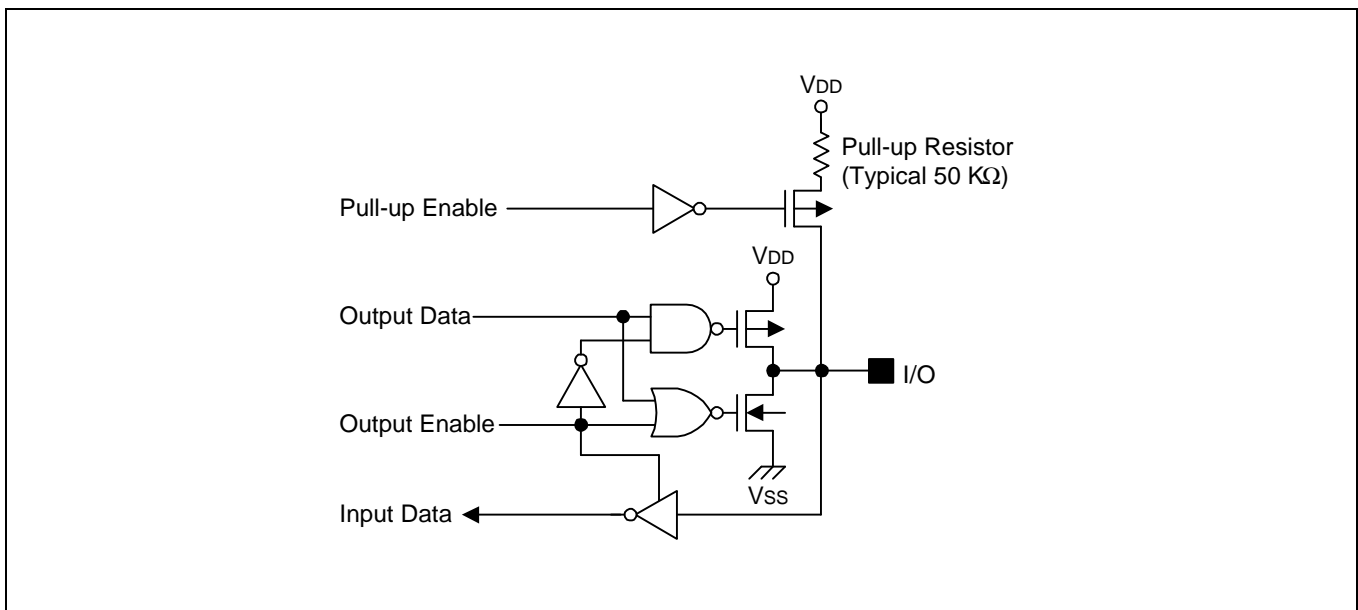

Figure 1-6. IOPU (Input/Output Pin with Programmable Pull-up Resistor)

NOTES

2 PROGRAMMER'S MODEL

OVERVIEW

S3F443FX was developed using the advanced ARM7TDMI core designed by Advanced RISC Machines, Ltd and it supports only Big Endian mode.

PROCESSOR OPERATING STATES

From the programmer's point of view, the ARM7TDMI can be in one of two states:

- ARM state which executes 32-bit, word-aligned ARM instructions.
- THUMB state which operates with 16-bit, half-word-aligned THUMB instructions. In this state, the PC uses bit 1 to select between alternate half-words.

NOTE

Transition between these two states does not affect the processor mode or the contents of the registers.

SWITCHING STATE

Entering THUMB State

Entry into THUMB state can be achieved by executing a BX instruction with the state bit (bit 0) set in the operand register.

Transition to THUMB state will also occur automatically on return from an exception (IRQ, FIQ, UNDEF, ABORT, SWI etc.), if the exception was entered with the processor in THUMB state.

Entering ARM State

Entry into ARM state happens:

- On execution of the BX instruction with the state bit clear in the operand register.
- On the processor taking an exception (IRQ, FIQ, RESET, UNDEF, ABORT, SWI etc.). In this case, the PC is placed in the exception mode's link register, and execution commences at the exception's vector address.

MEMORY FORMATS

ARM7TDMI views memory as a linear collection of bytes numbered upwards from zero. Bytes 0 to 3 hold the first stored word, bytes 4 to 7 the second and so on. ARM7TDMI can treat words in memory as being stored either in Big-Endian or Little-Endian format.

BIG-ENDIAN FORMAT

In Big-Endian format, the most significant byte of a word is stored at the lowest numbered byte and the least significant byte at the highest numbered byte. Byte 0 of the memory system is therefore connected to data lines 31 through 24.

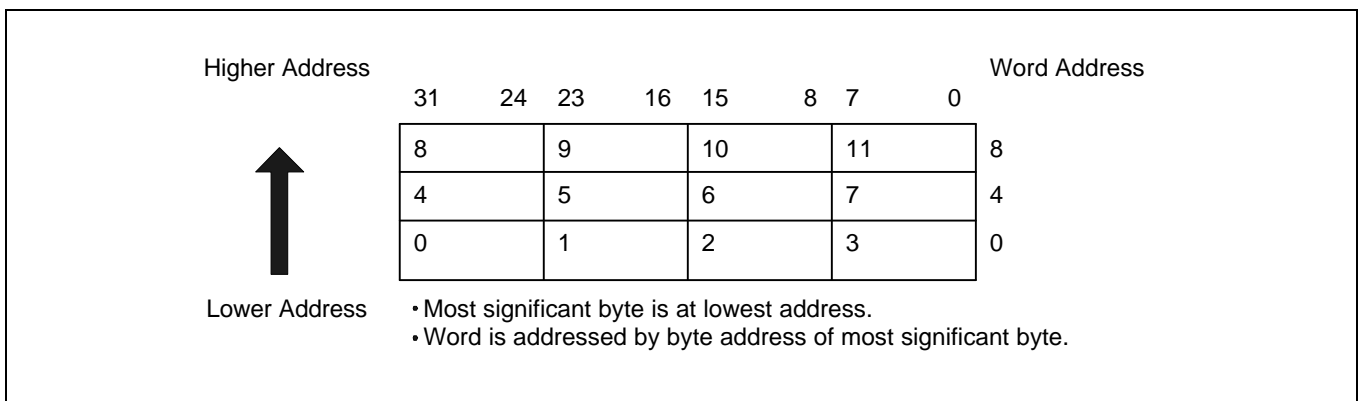

Figure 2-1. Big-Endian Addresses of Bytes within Words

LITTLE-ENDIAN FORMAT

In Little-Endian format, the lowest numbered byte in a word is considered the word's least significant byte, and the highest numbered byte the most significant. Byte 0 of the memory system is therefore connected to data lines 7 through 0. (**NOTE:** S3F443FX does not support Little-Endian)

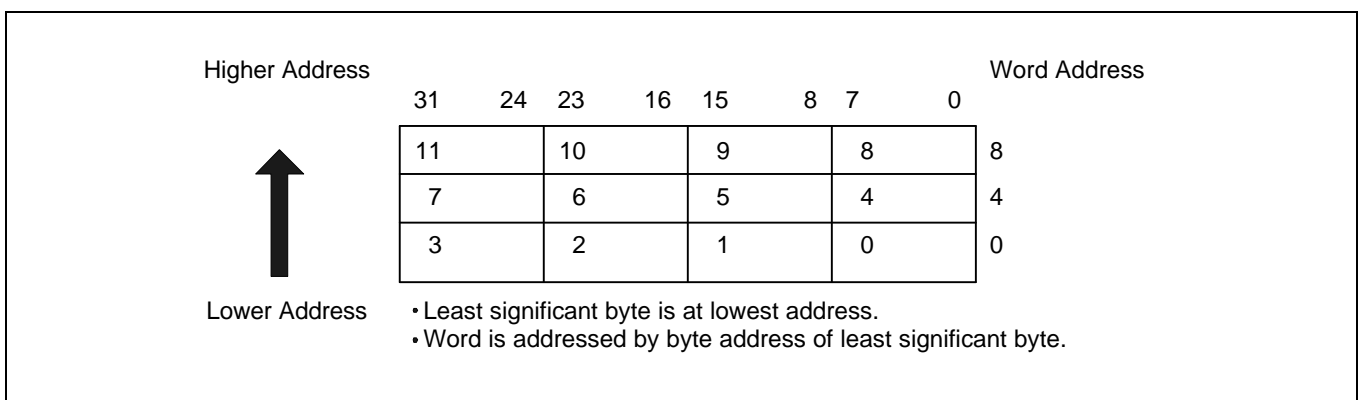

Figure 2-2. Little-Endian Addresses of Bytes within Words

INSTRUCTION LENGTH

Instructions are either 32 bits long (in ARM state) or 16 bits long (in THUMB state).

Data Types

ARM7TDMI supports byte (8-bit), half-word (16-bit) and word (32-bit) data types. Words must be aligned to four-byte boundaries and half words to two-byte boundaries.

OPERATING MODES

ARM7TDMI supports seven modes of operation:

- User (usr): The normal ARM program execution state
- FIQ (fiq): Designed to support a data transfer or channel process
- IRQ (irq): Used for general-purpose interrupt handling
- Supervisor (svc): Protected mode for the operating system
- Abort mode (abt): Entered after a data or instruction pre-fetch abort
- System (sys): A privileged user mode for the operating system
- Undefined (und): Entered when an undefined instruction is executed

Mode changes may be made under software control, or may be brought about by external interrupts or exception processing. Most application programs will execute in User mode. The non-user modes' known as privileged modes-are entered in order to service interrupts or exceptions, or to access protected resources.

REGISTERS

ARM7TDMI has a total of 37 registers - 31 general-purpose 32-bit registers and six status registers - but these cannot all be seen at once. The processor state and operating mode dictate which registers are available to the programmer.

The ARM State Register Set

In ARM state, 16 general registers and one or two status registers are visible at any one time. In privileged (non-User) modes, mode-specific banked registers are switched in. Figure 2-3 shows which registers are available in each mode: the banked registers are marked with a shaded triangle.

The ARM state register set contains 16 directly accessible registers: R0 to R15. All of these except R15 are general-purpose, and may be used to hold either data or address values. In addition to these, there is a seventeenth register used to store status information.

Register 14	is used as the subroutine link register. This receives a copy of R15 when a Branch and Link (BL) instruction is executed. At all other times it may be treated as a general-purpose register. The corresponding banked registers R14_svc, R14_irq, R14_fiq, R14_abt and R14_und are similarly used to hold the return values of R15 when interrupts and exceptions arise, or when Branch and Link instructions are executed within interrupt or exception routines.
Register 15	holds the Program Counter (PC). In ARM state, bits [1:0] of R15 are zero and bits [31:2] contain the PC. In THUMB state, bit [0] is zero and bits [31:1] contain the PC.
Register 16	is the CPSR (Current Program Status Register). This contains condition code flags and the current mode bits.

FIQ mode has seven banked registers mapped to R8-14 (R8_fiq-R14_fiq). In ARM state, many FIQ handlers do not need to save any registers. User, IRQ, Supervisor, Abort and Undefined each have two banked registers mapped to R13 and R14, allowing each of these modes to have a private stack pointer and link registers.

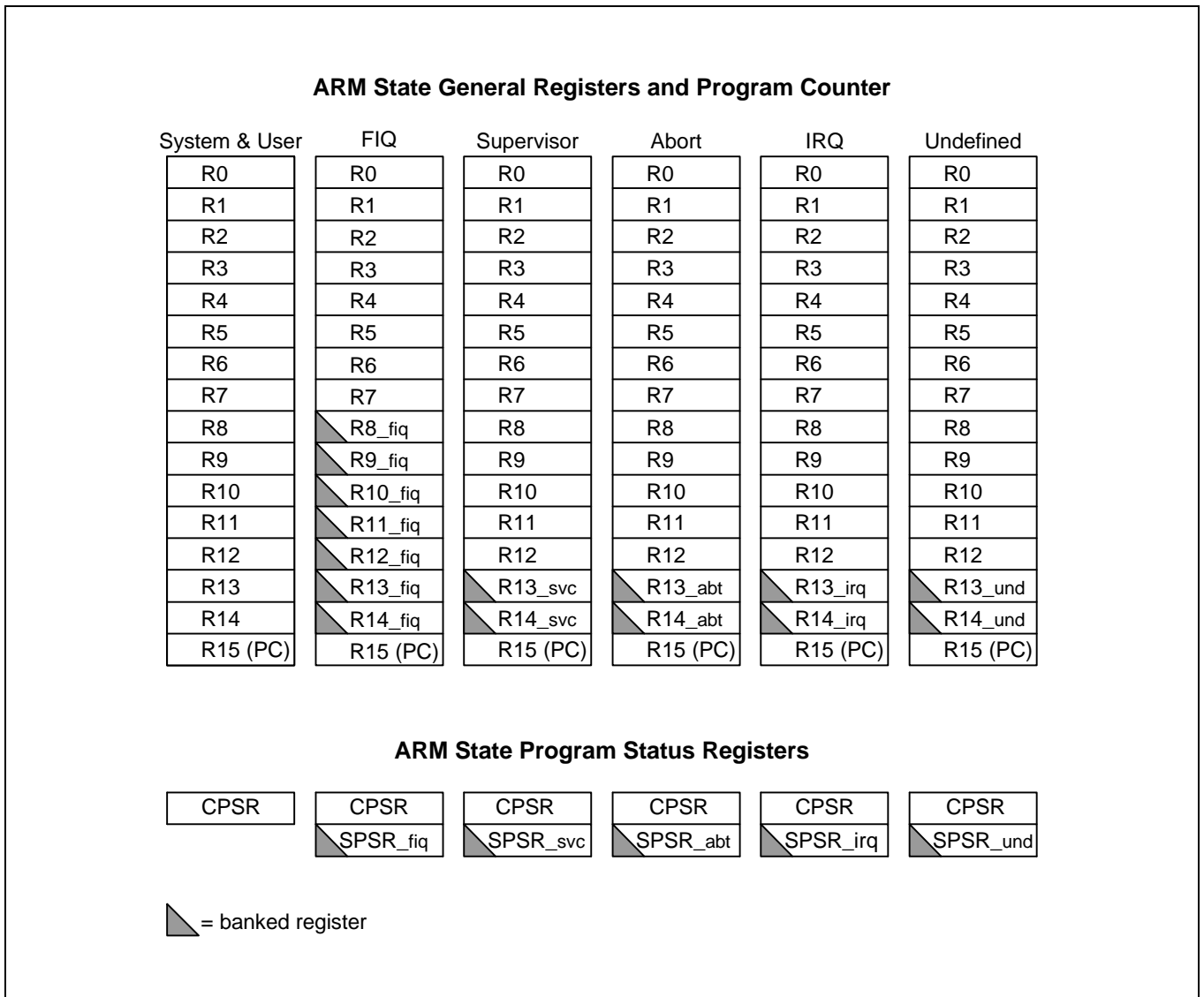

Figure 2-3. Register Organization in ARM State

The THUMB State Register Set

The THUMB state register set is a subset of the ARM state set. The programmer has direct access to eight general registers, R0-R7, as well as the Program Counter (PC), a stack pointer register (SP), a link register (LR), and the CPSR. There are banked Stack Pointers, Link Registers and Saved Process Status Registers (SPSRs) for each privileged mode. This is shown in Figure 2-4.

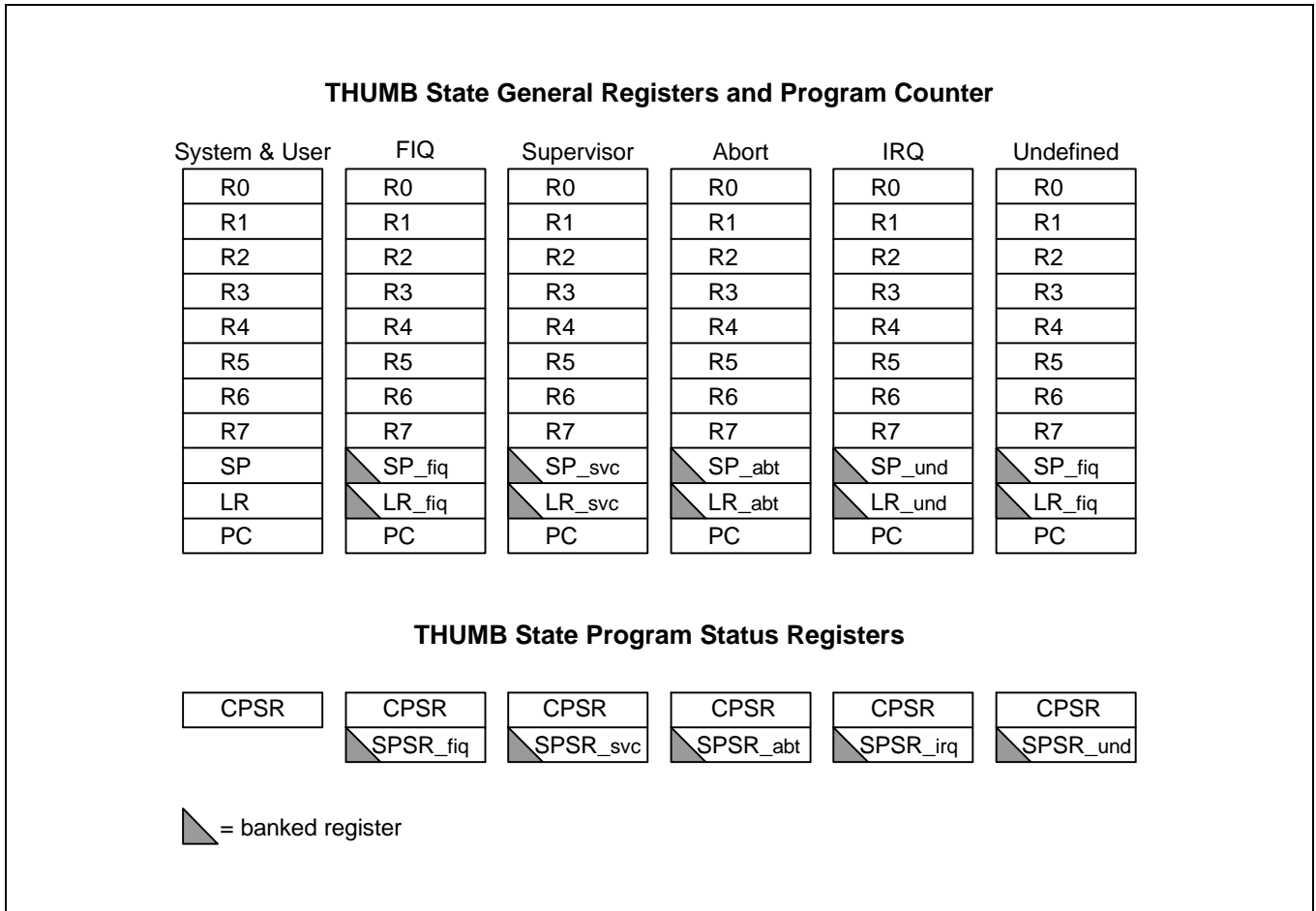

Figure 2-4. Register Organization in THUMB state

The relationship between ARM and THUMB state registers

The THUMB state registers relate to the ARM state registers in the following way:

- THUMB state R0-R7 and ARM state R0-R7 are identical
- THUMB state CPSR and SPSRs and ARM state CPSR and SPSRs are identical
- THUMB state SP maps onto ARM state R13
- THUMB state LR maps onto ARM state R14
- The THUMB state Program Counter maps onto the ARM state Program Counter (R15)

This relationship is shown in Figure 2-5.

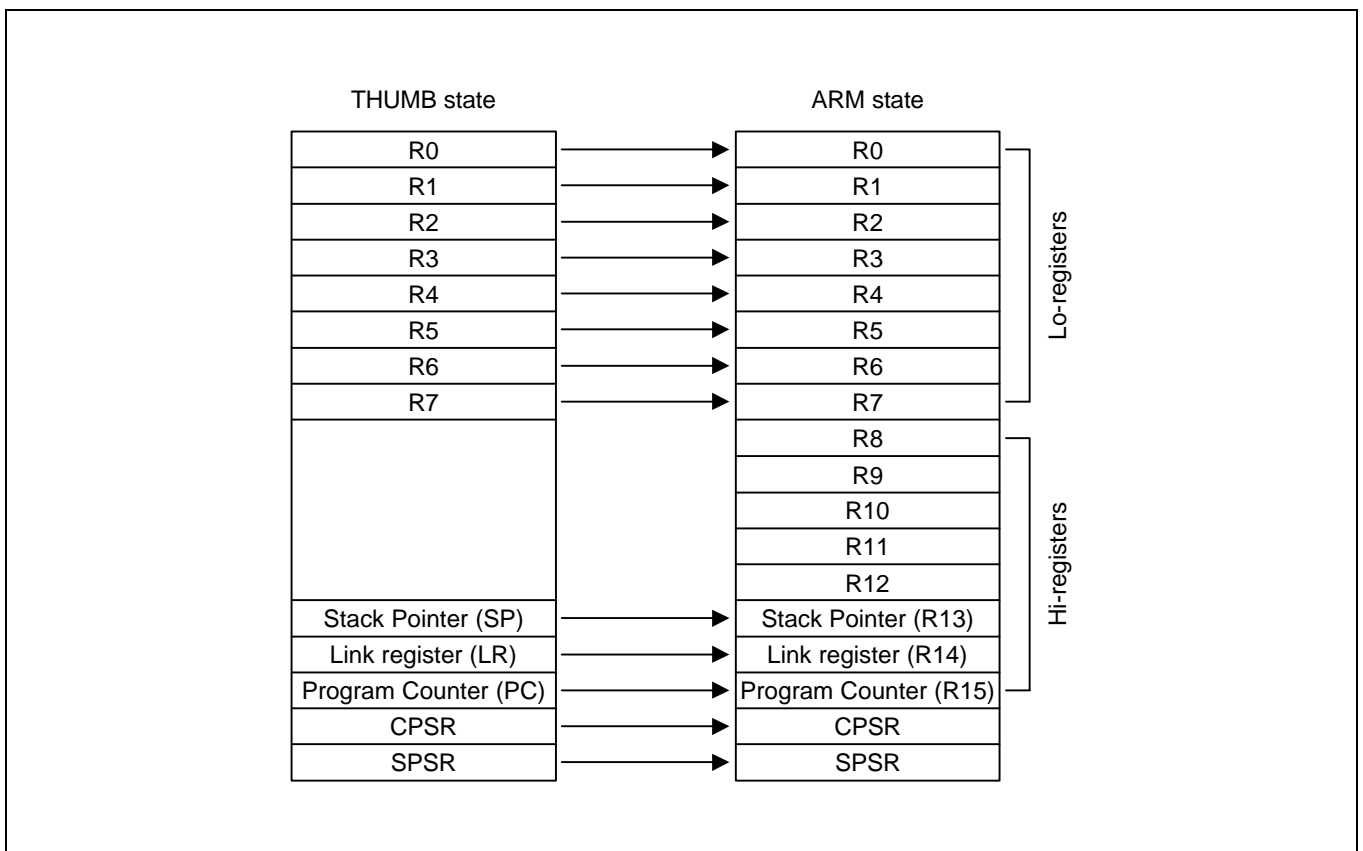

Figure 2-5. Mapping of THUMB State Registers onto ARM State Registers

Accessing Hi-Registers in THUMB State

In THUMB state, registers R8-R15 (the Hi registers) are not part of the standard register set. However, the assembly language programmer has limited access to them, and can use them for fast temporary storage.

A value may be transferred from a register in the range R0-R7 (a Lo register) to a Hi register, and from a Hi register to a Lo register, using special variants of the MOV instruction. Hi register values can also be compared against or added to Lo register values with the CMP and ADD instructions. For more information, refer to Figure 3-34.

THE PROGRAM STATUS REGISTERS

The ARM7TDMI contains a Current Program Status Register (CPSR), plus five Saved Program Status Registers (SPSRs) for use by exception handlers. These registers' functions are:

- Hold information about the most recently performed ALU operation
- Control the enabling and disabling of interrupts
- Set the processor operating mode

The arrangement of bits is shown in Figure 2-6.

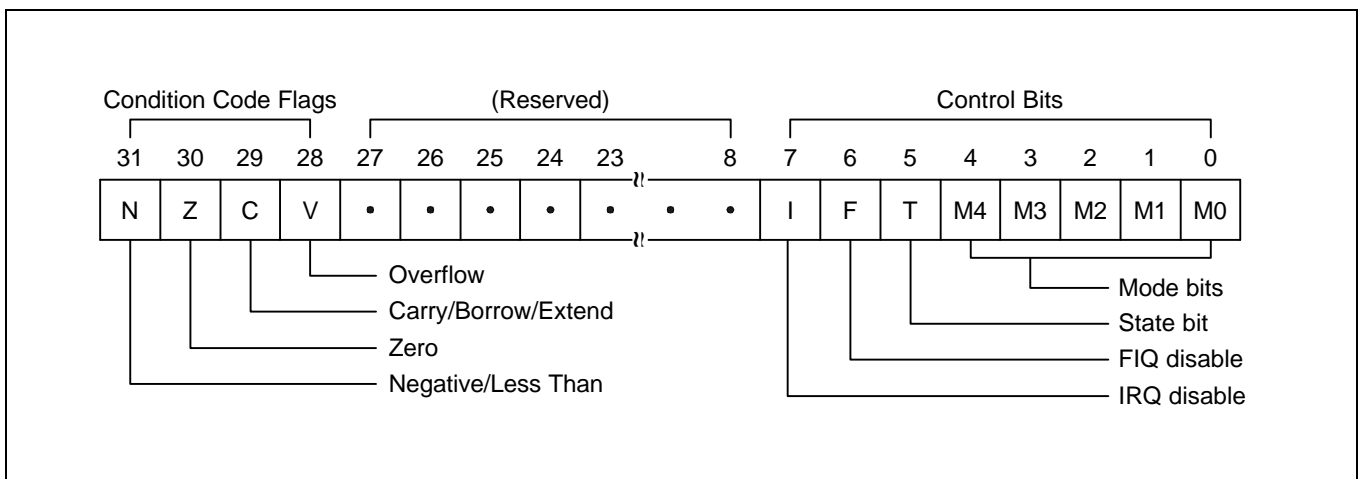

Figure 2-6. Program Status Register Format

The Condition Code Flags

The N, Z, C and V bits are the condition code flags. These may be changed as a result of arithmetic and logical operations, and may be tested to determine whether an instruction should be executed.

In ARM state, all instructions may be executed conditionally: see Table 3-2 for details.

In THUMB state, only the Branch instruction is capable of conditional execution: see Figure 3-46 for details.

The Control Bits

The bottom 8 bits of a PSR (incorporating I, F, T and M[4:0]) are known collectively as the control bits. These will be changed when an exception arises. If the processor is operating in a privileged mode, they can also be manipulated by software.

The T bit	This reflects the operating state. When this bit is set, the processor is executing in THUMB state, otherwise it is executing in ARM state. This is reflected on the TBIT external signal. Note that the software must never change the state of the TBIT in the CPSR. If this happens, the processor will enter an unpredictable state.
Interrupt disable bits	The I and F bits are the interrupt disable bits. When set, these disable the IRQ and FIQ interrupts respectively.
The mode bits	The M4, M3, M2, M1 and M0 bits (M[4:0]) are the mode bits. These determine the processor's operating mode, as shown in Table 2-1. Not all combinations of the mode bits define a valid processor mode. Only those explicitly described shall be used. The user should be aware that if any illegal value is programmed into the mode bits, M[4:0], then the processor will enter an unrecoverable state. If this occurs, reset should be applied.
Reserved bits	The remaining bits in the PSRs are reserved. When changing a PSR's flag or control bits, you must ensure that these unused bits are not altered. Also, your program should not rely on them containing specific values, since in future processors they may read as one or zero.

Table 2-1. PSR Mode Bit Values

M[4:0]	Mode	Visible THUMB State Registers	Visible ARM State Registers
10000	User	R7..R0, LR, SP PC, CPSR	R14..R0, PC, CPSR
10001	FIQ	R7..R0, LR_fiq, SP_fiq PC, CPSR, SPSR_fiq	R7..R0, R14_fiq..R8_fiq, PC, CPSR, SPSR_fiq
10010	IRQ	R7..R0, LR_irq, SP_irq PC, CPSR, SPSR_irq	R12..R0, R14_irq, R13_irq, PC, CPSR, SPSR_irq
10011	Supervisor	R7..R0, LR_svc, SP_svc, PC, CPSR, SPSR_svc	R12..R0, R14_svc, R13_svc, PC, CPSR, SPSR_svc
10111	Abort	R7..R0, LR_abt, SP_abt, PC, CPSR, SPSR_abt	R12..R0, R14_abt, R13_abt, PC, CPSR, SPSR_abt
11011	Undefined	R7..R0 LR_und, SP_und, PC, CPSR, SPSR_und	R12..R0, R14_und, R13_und, PC, CPSR
11111	System	R7..R0, LR, SP PC, CPSR	R14..R0, PC, CPSR

Reserved bits

The remaining bits in the PSR's are reserved. When changing a PSR's flag or control bits, you must ensure that these unused bits are not altered. Also, your program should not rely on them containing specific values, since in future processors they may read as one or zero.

EXCEPTIONS

Exceptions arise whenever the normal flow of a program has to be halted temporarily, for example to service an interrupt from a peripheral. Before an exception can be handled, the current processor state must be preserved so that the original program can resume when the handler routine has finished.

It is possible for several exceptions to arise at the same time. If this happens, they are dealt with in a fixed order. See Exception Priorities on page 2-14.

Action on Entering an Exception

When handling an exception, the ARM7TDMI:

1. Preserves the address of the next instruction in the appropriate Link Register. If the exception has been entered from ARM state, then the address of the next instruction is copied into the Link Register (that is, current PC + 4 or PC + 8 depending on the exception. See Table 2-2 on for details). If the exception has been entered from THUMB state, then the value written into the Link Register is the current PC offset by a value such that the program resumes from the correct place on return from the exception. This means that the exception handler need not determine which state the exception was entered from. For example, in the case of SWI, MOV_S PC, R14_svc will always return to the next instruction regardless of whether the SWI was executed in ARM or THUMB state.
2. Copies the CPSR into the appropriate SPSR
3. Forces the CPSR mode bits to a value which depends on the exception
4. Forces the PC to fetch the next instruction from the relevant exception vector

It may also set the interrupt disable flags to prevent otherwise unmanageable nesting of exceptions.

If the processor is in THUMB state when an exception occurs, it will automatically switch into ARM state when the PC is loaded with the exception vector address.

Action on Leaving an Exception

On completion, the exception handler:

1. Moves the Link Register, minus an offset where appropriate, to the PC. (The offset will vary depending on the type of exception.)
2. Copies the SPSR back to the CPSR
3. Clears the interrupt disable flags, if they were set on entry

NOTE

An explicit switch back to THUMB state is never needed, since restoring the CPSR from the SPSR automatically sets the T bit to the value it held immediately prior to the exception.

Exception Entry/Exit Summary

Table 2-2 summarizes the PC value preserved in the relevant R14 on exception entry, and the recommended instruction for exiting the exception handler.

Table 2-2. Exception Entry/Exit

	Return Instruction	Previous State		Notes
		ARM R14_x	THUMB R14_x	
BL	MOV PC, R14	PC + 4	PC + 2	1
SWI	MOVS PC, R14_svc	PC + 4	PC + 2	1
UDEF	MOVS PC, R14_und	PC + 4	PC + 2	1
FIQ	SUBS PC, R14_fiq, #4	PC + 4	PC + 4	2
IRQ	SUBS PC, R14_irq, #4	PC + 4	PC + 4	2
PABT	SUBS PC, R14_abt, #4	PC + 4	PC + 4	1
DABT	SUBS PC, R14_abt, #8	PC + 8	PC + 8	3
RESET	NA	–	–	4

NOTES:

1. Where PC is the address of the BL/SWI/Undefined Instruction fetch which had the prefetch abort.
2. Where PC is the address of the instruction which did not get executed since the FIQ or IRQ took priority.
3. Where PC is the address of the Load or Store instruction which generated the data abort.
4. The value saved in R14_svc upon reset is unpredictable.

FIQ

The FIQ (Fast Interrupt Request) exception is designed to support a data transfer or channel process, and in ARM state has sufficient private registers to remove the need for register saving (thus minimizing the overhead of context switching).

FIQ is externally generated by taking the **nFIQ** input LOW. This input can except either synchronous or asynchronous transitions, depending on the state of the **ISYNC** input signal. When **ISYNC** is LOW, **nFIQ** and **nIRQ** are considered asynchronous, and a cycle delay for synchronization is incurred before the interrupt can affect the processor flow.

Irrespective of whether the exception was entered from ARM or Thumb state, a FIQ handler should leave the interrupt by executing

```
SUBS    PC,R14_fiq,#4
```

FIQ may be disabled by setting the CPSR's F flag (but note that this is not possible from User mode). If the F flag is clear, ARM7TDMI checks for a LOW level on the output of the FIQ synchroniser at the end of each instruction.

IRQ

The IRQ (Interrupt Request) exception is a normal interrupt caused by a LOW level on the **nIRQ** input. IRQ has a lower priority than FIQ and is masked out when a FIQ sequence is entered. It may be disabled at any time by setting the I bit in the CPSR, though this can only be done from a privileged (non-User) mode.

Irrespective of whether the exception was entered from ARM or Thumb state, an IRQ handler should return from the interrupt by executing

```
SUBS    PC,R14_irq,#4
```

Abort

An abort indicates that the current memory access cannot be completed. It can be signaled by the external **ABORT** input. ARM7TDMI checks for the abort exception during memory access cycles.

There are two types of abort:

- Prefetch abort: occurs during an instruction prefetch.
- Data abort: occurs during a data access.

If a prefetch abort occurs, the prefetched instruction is marked as invalid, but the exception will not be taken until the instruction reaches the head of the pipeline. If the instruction is not executed - for example because a branch occurs while it is in the pipeline - the abort does not take place.

If a data abort occurs, the action taken depends on the instruction type:

- Single data transfer instructions (LDR, STR) write back modified base registers: the Abort handler must be aware of this.
- The swap instruction (SWP) is aborted as though it had not been executed.
- Block data transfer instructions (LDM, STM) complete. If write-back is set, the base is updated. If the instruction would have overwritten the base with data (i.e. it has the base in the transfer list), the overwriting is prevented. All register overwriting is prevented after an abort is indicated, which means in particular that R15 (always the last register to be transferred) is preserved in an aborted LDM instruction.

The abort mechanism allows the implementation of a demand paged virtual memory system. In such a system the processor is allowed to generate arbitrary addresses. When the data at an address is unavailable, the Memory Management Unit (MMU) signals an abort. The abort handler must then work out the cause of the abort, make the requested data available, and retry the aborted instruction. The application program needs no knowledge of the amount of memory available to it, nor is its state in any way affected by the abort.

After fixing the reason for the abort, the handler should execute the following irrespective of the state (ARM or Thumb):

```
SUBS    PC,R14_abt,#4      ; for a prefetch abort, or
SUBS    PC,R14_abt,#8      ; for a data abort
```

This restores both the PC and the CPSR, and retries the aborted instruction.

Software Interrupt

The software interrupt instruction (SWI) is used for entering Supervisor mode, usually to request a particular supervisor function. A SWI handler should return by executing the following irrespective of the state (ARM or Thumb):

```
MOV    PC,R14_svc
```

This restores the PC and CPSR, and returns to the instruction following the SWI.

NOTE

nFIQ, nIRQ, ISYNC, LOCK, BIGEND, and ABORT pins exist only in the ARM7TDMI CPU core.

Undefined Instruction

When ARM7TDMI comes across an instruction which it cannot handle, it takes the undefined instruction trap. This mechanism may be used to extend either the THUMB or ARM instruction set by software emulation.

After emulating the failed instruction, the trap handler should execute the following irrespective of the state (ARM or Thumb):

```
MOVS  PC,R14_und
```

This restores the CPSR and returns to the instruction following the undefined instruction.

Exception Vectors

The following table shows the exception vector addresses.

Table 2-3. Exception Vectors

Address	Exception	Mode in Entry
0x00000000	Reset	Supervisor
0x00000004	Undefined instruction	Undefined
0x00000008	Software Interrupt	Supervisor
0x0000000C	Abort (prefetch)	Abort
0x00000010	Abort (data)	Abort
0x00000014	Reserved	Reserved
0x00000018	IRQ	IRQ
0x0000001C	FIQ	FIQ

Exception Priorities

When multiple exceptions arise at the same time, a fixed priority system determines the order in which they are handled:

Highest priority:

1. Reset
2. Data abort
3. FIQ
4. IRQ
5. Prefetch abort

Lowest priority:

6. Undefined Instruction, Software interrupt.

Not All Exceptions Can Occur at Once:

Undefined Instruction and Software Interrupt are mutually exclusive, since they each correspond to particular (non-overlapping) decoding of the current instruction.

If a data abort occurs at the same time as a FIQ, and FIQs are enabled (i.e. the CPSR's F flag is clear), ARM7TDMI enters the data abort handler and then immediately proceeds to the FIQ vector. A normal return from FIQ will cause the data abort handler to resume execution. Placing data abort at a higher priority than FIQ is necessary to ensure that the transfer error does not escape detection. The time for this exception entry should be added to worst-case FIQ latency calculations.

INTERRUPT LATENCIES

The worst case latency for FIQ, assuming that it is enabled, consists of the longest time the request can take to pass through the synchroniser ($T_{syncmax}$ if asynchronous), plus the time for the longest instruction to complete (T_{ldm} , the longest instruction is an LDM which loads all the registers including the PC), plus the time for the data abort entry (T_{exc}), plus the time for FIQ entry (T_{fiq}). At the end of this time ARM7TDMI will be executing the instruction at 0x1C.

$T_{syncmax}$ is 3 processor cycles, T_{ldm} is 20 cycles, T_{exc} is 3 cycles, and T_{fiq} is 2 cycles. The total time is therefore 28 processor cycles. This is just over 1.4 microseconds in a system which uses a continuous 20 MHz processor clock. The maximum IRQ latency calculation is similar, but must allow for the fact that FIQ has higher priority and could delay entry into the IRQ handling routine for an arbitrary length of time. The minimum latency for FIQ or IRQ consists of the shortest time the request can take through the synchroniser ($T_{syncmin}$) plus T_{fiq} . This is 4 processor cycles.

RESET

When the **nRESET** signal goes LOW, ARM7TDMI abandons the executing instruction and then continues to fetch instructions from incrementing word addresses.

When **nRESET** goes HIGH again, ARM7TDMI:

1. Overwrites R14_svc and SPSR_svc by copying the current values of the PC and CPSR into them. The value of the saved PC and SPSR is not defined.
2. Forces M[4:0] to 10011 (Supervisor mode), sets the I and F bits in the CPSR, and clears the CPSR's T bit.
3. Forces the PC to fetch the next instruction from address 0x00.
4. Execution resumes in ARM state.

3 INSTRUCTION SET

INSTRUCTION SET SUMMARY

This chapter describes the ARM instruction set and the THUMB instruction set in the ARM7TDMI core.

FORMAT SUMMARY

The ARM instruction set formats are shown below.

31 30 29 28 27 26 25 24 23 22 21 20 19 18 17 16 15 14 13 12 11 10 9 8 7 6 5 4 3 2 1 0																															
Cond	0	0	I	Opcode				S	Rn	Rd	Operand2											Data Processing/ PSR Transfer									
Cond	0	0	0	0	0	0	0	A	S	Rd	Rn	Rs	1	0	0	1	Rm	Multiply													
Cond	0	0	0	0	1	U	A	S	RdHi	RdLo	Rn	1	0	0	1	Rm	Multiply Long														
Cond	0	0	0	1	0	B	0	0	Rn	Rd	0	0	0	0	1	0	0	1	Rm	Single Data Swap											
Cond	0	0	0	1	0	0	1	0	1	1	1	1	1	1	1	1	1	1	0	0	0	1	Rn	Branch and Exchange							
Cond	0	0	0	P	U	0	W	L	Rn	Rd	0	0	0	0	1	S	H	1	Rm	Halfword Data Transfer: register offset											
Cond	0	0	0	P	U	1	W	L	Rn	Rd	Offset				1	S	H	1	Offset	Halfword Data Transfer: immediate offset											
Cond	0	1	I	P	U	B	W	L	Rn	Rd	Offset											Single Data Transfer									
Cond	0	1	I																	1		Undefined									
Cond	1	0	0	P	U	B	W	L	Rn	Register List											Block Data Transfer										
Cond	1	0	1	L	Offset																Branch										
Cond	1	1	0	P	U	B	W	L	Rn	CRd	CP#	Offset									Coprocessor Data Transfer										
Cond	1	1	1	0	CP Opc			CRn	CRd	CP#	CP	0	CRm									Coprocessor Data Operation									
Cond	1	1	1	0	CP Opc		L	CRn	Rd	CP#	CP	1	CRm									Coprocessor Register Transfer									
Cond	1	1	1	1	Ignored by processor																Software Interrupt										
31 30 29 28 27 26 25 24 23 22 21 20 19 18 17 16 15 14 13 12 11 10 9 8 7 6 5 4 3 2 1 0																															

Figure 3-1. ARM Instruction Set Format

NOTE

Some instruction codes are not defined but do not cause the Undefined instruction trap to be taken, for instance a Multiply instruction with bit 6 changed to a 1. These instructions should not be used, as their action may change in future ARM implementations.

INSTRUCTION SUMMARY**Table 3-1. The ARM Instruction Set**

Mnemonic	Instruction	Action
ADC	Add with carry	Rd: = Rn + Op2 + Carry
ADD	Add	Rd: = Rn + Op2
AND	AND	Rd: = Rn AND Op2
B	Branch	R15: = address
BIC	Bit Clear	Rd: = Rn AND NOT Op2
BL	Branch with Link	R14: = R15, R15: = address
BX	Branch and Exchange	R15: = Rn, T bit: = Rn[0]
CDP	Coprocessor Data Processing	(Coprocessor-specific)
CMN	Compare Negative	CPSR flags: = Rn + Op2
CMP	Compare	CPSR flags: = Rn - Op2
EOR	Exclusive OR	Rd: = (Rn AND NOT Op2) OR (Op2 AND NOT Rn)
LDC	Load coprocessor from memory	Coprocessor load
LDM	Load multiple registers	Stack manipulation (Pop)
LDR	Load register from memory	Rd: = (address)
MCR	Move CPU register to coprocessor register	cRn: = rRn {<op>cRm}
MLA	Multiply Accumulate	Rd: = (Rm × Rs) + Rn
MOV	Move register or constant	Rd: = Op2

Table 3-1. The ARM Instruction Set (Continued)

Mnemonic	Instruction	Action
MRC	Move from coprocessor register to CPU register	Rd: = cRn {<op>cRm}
MRS	Move PSR status/flags to register	Rd: = PSR
MSR	Move register to PSR status/flags	PSR: = Rm
MUL	Multiply	Rd: = Rm × Rs
MVN	Move negative register	Rd: = Not Op2
ORR	OR	Rd: = Rn OR Op2
RSB	Reverse Subtract	Rd: = Op2 - Rn
RSC	Reverse Subtract with Carry	Rd: = Op2 - Rn - Not Carry Flag
SBC	Subtract with Carry	Rd: = Rn - Op2 - Not Carry Flag
STC	Store coprocessor register to memory	address: = CRn
STM	Store Multiple	Stack manipulation (Push)
STR	Store register to memory	<address>: = Rd
SUB	Subtract	Rd: = Rn - Op2
SWI	Software Interrupt	OS call
SWP	Swap register with memory	Rd: = [Rn], [Rn] := Rm
TEQ	Test bitwise equality	CPSR flags: = Rn EOR Op2
TST	Test bits	CPSR flags: = Rn AND Op2

THE CONDITION FIELD

In ARM state, all instructions are conditionally executed according to the state of the CPSR condition codes and the instruction's condition field. This field (bits 31:28) determines the circumstances under which an instruction is to be executed. If the state of the C, N, Z and V flags fulfils the conditions encoded by the field, the instruction is executed, otherwise it is ignored.

There are sixteen possible conditions, each represented by a two-character suffix that can be appended to the instruction's mnemonic. For example, a Branch (B in assembly language) becomes BEQ for "Branch if Equal", which means the Branch will only be taken if the Z flag is set.

In practice, fifteen different conditions may be used: these are listed in Table 3-2. The sixteenth (1111) is reserved, and must not be used.

In the absence of a suffix, the condition field of most instructions is set to "Always" (suffix AL). This means the instruction will always be executed regardless of the CPSR condition codes.

Table 3-2. Condition Code Summary

Code	Suffix	Flags	Meaning
0000	EQ	Z set	equal
0001	NE	Z clear	not equal
0010	CS	C set	unsigned higher or same
0011	CC	C clear	unsigned lower
0100	MI	N set	negative
0101	PL	N clear	positive or zero
0110	VS	V set	overflow
0111	VC	V clear	no overflow
1000	HI	C set and Z clear	unsigned higher
1001	LS	C clear or Z set	unsigned lower or same
1010	GE	N equals V	greater or equal
1011	LT	N not equal to V	less than
1100	GT	Z clear AND (N equals V)	greater than
1101	LE	Z set OR (N not equal to V)	less than or equal
1110	AL	(ignored)	always

BRANCH AND EXCHANGE (BX)

This instruction is only executed if the condition is true. The various conditions are defined in Table 3-2.

This instruction performs a branch by copying the contents of a general register, Rn, into the program counter, PC. The branch causes a pipeline flush and refill from the address specified by Rn. This instruction also permits the instruction set to be exchanged. When the instruction is executed, the value of Rn[0] determines whether the instruction stream will be decoded as ARM or THUMB instructions.

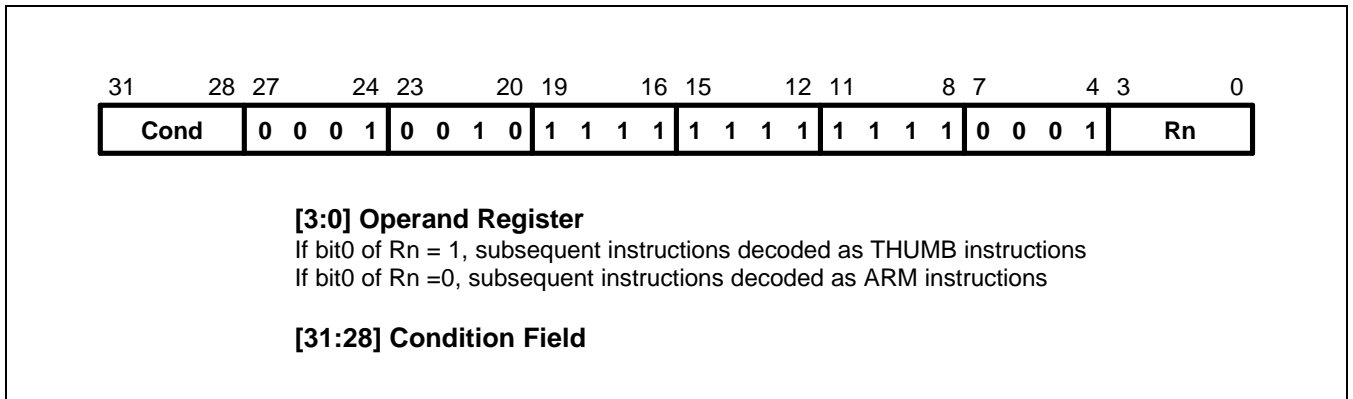

Figure 3-2. Branch and Exchange Instructions

INSTRUCTION CYCLE TIMES

The BX instruction takes 2S + 1N cycles to execute, where S and N are defined as sequential (S-cycle) and non-sequential (N-cycle), respectively.

ASSEMBLER SYNTAX

BX - branch and exchange.

BX {cond} Rn

{cond} Two character condition mnemonic. See Table 3-2.

Rn is an expression evaluating to a valid register number.

USING R15 AS AN OPERAND

If R15 is used as an operand, the behavior is undefined.

EXAMPLES

```
ADR      R0, Into_THUMB + 1      ; Generate branch target address
                                     ; and set bit 0 high - hence
                                     ; arrive in THUMB state.
BX       R0                       ; Branch and change to THUMB
                                     ; state.
CODE16   ; Assemble subsequent code as
Into_THUMB ; THUMB instructions
•
•
•
ADR R5, Back_to_ARM              ; Generate branch target to word aligned address
                                     ; - hence bit 0 is low and so change back to ARM state.
BX R5                             ; Branch and change back to ARM state.
•
•
•
ALIGN   ; Word align
CODE32  ; Assemble subsequent code as ARM instructions
Back_to_ARM
```

BRANCH AND BRANCH WITH LINK (B, BL)

The instruction is only executed if the condition is true. The various conditions are defined Table 3-2. The instruction encoding is shown in Figure 3-3, below.

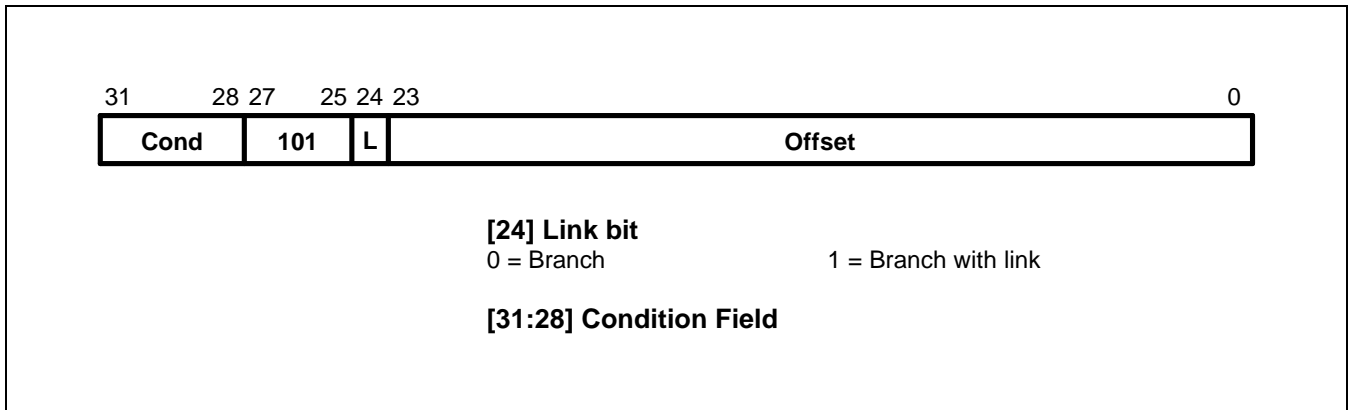

Figure 3-3. Branch Instructions

Branch instructions contain a signed 2's complement 24 bit offset. This is shifted left two bits, sign extended to 32 bits, and added to the PC. The instruction can therefore specify a branch of +/- 32Mbytes. The branch offset must take account of the prefetch operation, which causes the PC to be 2 words (8 bytes) ahead of the current instruction.

Branches beyond +/- 32Mbytes must use an offset or absolute destination which has been previously loaded into a register. In this case the PC should be manually saved in R14 if a Branch with Link type operation is required.

THE LINK BIT

Branch with Link (BL) writes the old PC into the link register (R14) of the current bank. The PC value written into R14 is adjusted to allow for the prefetch, and contains the address of the instruction following the branch and link instruction. Note that the CPSR is not saved with the PC and R14[1:0] are always cleared.

To return from a routine called by Branch with Link use MOV PC,R14 if the link register is still valid or LDM Rn!,{..PC} if the link register has been saved onto a stack pointed to by Rn.

INSTRUCTION CYCLE TIMES

Branch and Branch with Link instructions take $2S + 1N$ incremental cycles, where S and N are defined as sequential (S-cycle) and internal (I-cycle).

ASSEMBLER SYNTAX

Items in {} are optional. Items in <> must be present.

B{L}{cond} <expression>

{L} Used to request the Branch with Link form of the instruction. If absent, R14 will not be affected by the instruction.

{cond} A two-character mnemonic as shown in Table 3-2. If absent then AL (ALways) will be used.

<expression> The destination. The assembler calculates the offset.

EXAMPLES

here	BAL	here	; Assembles to 0xEAFFFFF0 (note effect of PC offset).
	B	there	; Always condition used as default.
	CMP	R1,#0	; Compare R1 with zero and branch to fred
			; if R1 was zero, otherwise continue.
	BEQ	fred	; Continue to next instruction.
	BL	sub+ROM	; Call subroutine at computed address.
	ADDS	R1,#1	; Add 1 to register 1, setting CPSR flags
			; on the result then call subroutine if
	BLCC	sub	; the C flag is clear, which will be the
			; case unless R1 held 0xFFFFFFFF.

DATA PROCESSING

The data processing instruction is only executed if the condition is true. The conditions are defined in Table 3-2. The instruction encoding is shown in Figure 3-4.

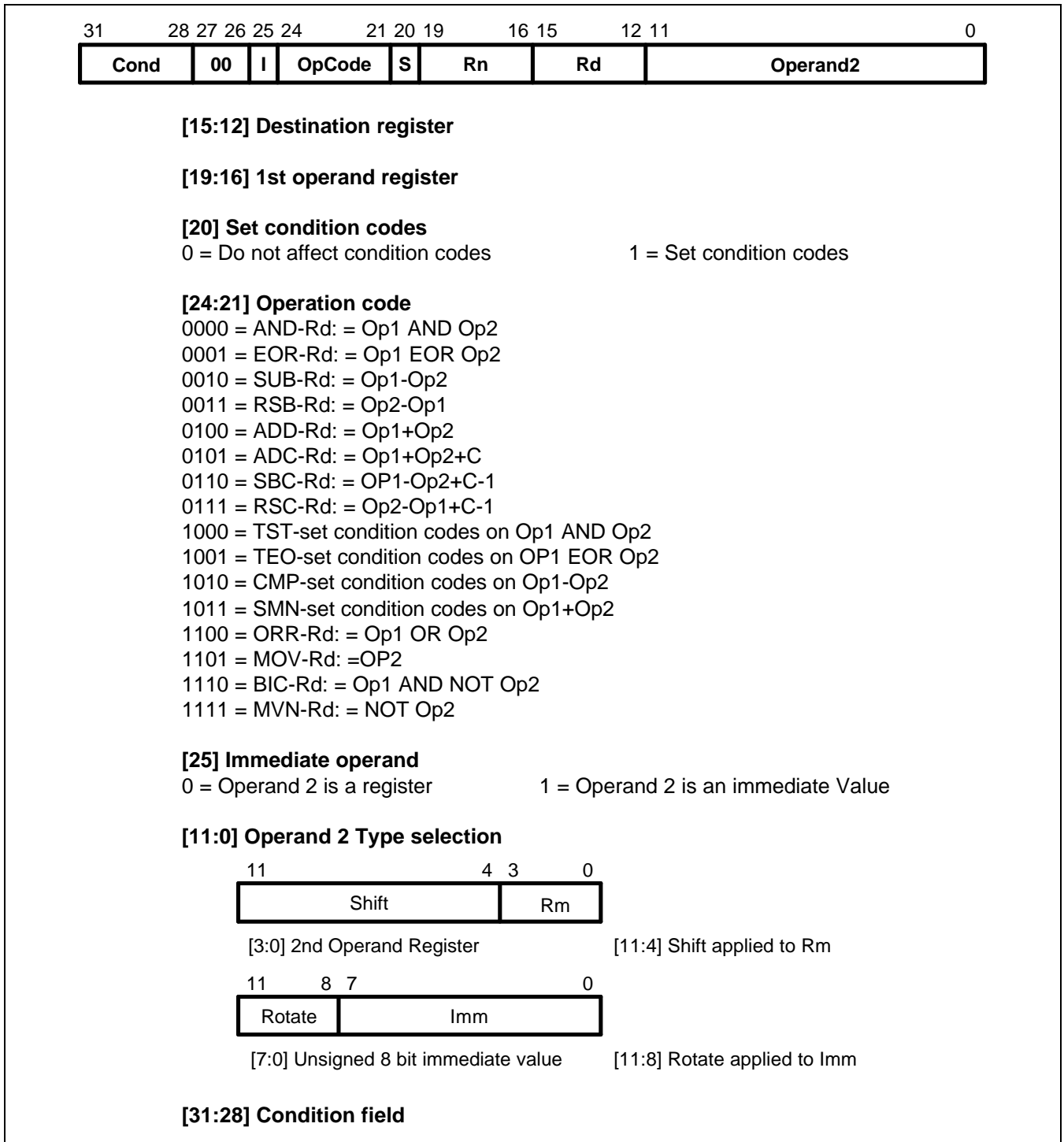

Figure 3-4. Data Processing Instructions

The instruction produces a result by performing a specified arithmetic or logical operation on one or two operands. The first operand is always a register (Rn).

The second operand may be a shifted register (Rm) or a rotated 8 bit immediate value (Imm) according to the value of the I bit in the instruction. The condition codes in the CPSR may be preserved or updated as a result of this instruction, according to the value of the S bit in the instruction.

Certain operations (TST, TEQ, CMP, CMN) do not write the result to Rd. They are used only to perform tests and to set the condition codes on the result and always have the S bit set. The instructions and their effects are listed in Table 3-3.

CPSR FLAGS

The data processing operations may be classified as logical or arithmetic. The logical operations (AND, EOR, TST, TEQ, ORR, MOV, BIC, MVN) perform the logical action on all corresponding bits of the operand or operands to produce the result. If the S bit is set (and Rd is not R15, see below) the V flag in the CPSR will be unaffected, the C flag will be set to the carry out from the barrel shifter (or preserved when the shift operation is LSL #0), the Z flag will be set if and only if the result is all zeros, and the N flag will be set to the logical value of bit 31 of the result.

Table 3-3. ARM Data Processing Instructions

Assembler Mnemonic	OP Code	Action
AND	0000	Operand1 AND operand2
EOR	0001	Operand1 EOR operand2
SUB	0010	Operand1 - operand2
RSB	0011	Operand2 operand1
ADD	0100	Operand1 + operand2
ADC	0101	Operand1 + operand2 + carry
SBC	0110	Operand1 - operand2 -Not carry flag
RSC	0111	Operand2 - operand1 Not carry flag
TST	1000	As AND, but result is not written
TEQ	1001	As EOR, but result is not written
CMP	1010	As SUB, but result is not written
CMN	1011	As ADD, but result is not written
ORR	1100	Operand1 OR operand2
MOV	1101	Operand2 (operand1 is ignored)
BIC	1110	Operand1 AND NOT operand2 (Bit clear)
MVN	1111	NOT operand2 (operand1 is ignored)

The arithmetic operations (SUB, RSB, ADD, ADC, SBC, RSC, CMP, CMN) treat each operand as a 32 bit integer (either unsigned or 2's complement signed, the two are equivalent). If the S bit is set (and Rd is not R15) the V flag in the CPSR will be set if an overflow occurs into bit 31 of the result; this may be ignored if the operands were considered unsigned, but warns of a possible error if the operands were 2's complement signed. The C flag will be set to the carry out of bit 31 of the ALU, the Z flag will be set if and only if the result was zero, and the N flag will be set to the value of bit 31 of the result (indicating a negative result if the operands are considered to be 2's complement signed).

SHIFTS

When the second operand is specified to be a shifted register, the operation of the barrel shifter is controlled by the Shift field in the instruction. This field indicates the type of shift to be performed (logical left or right, arithmetic right or rotate right). The amount by which the register should be shifted may be contained in an immediate field in the instruction, or in the least-significant byte of another register (other than R15). The encoding for the different shift types is shown in Figure 3-5.

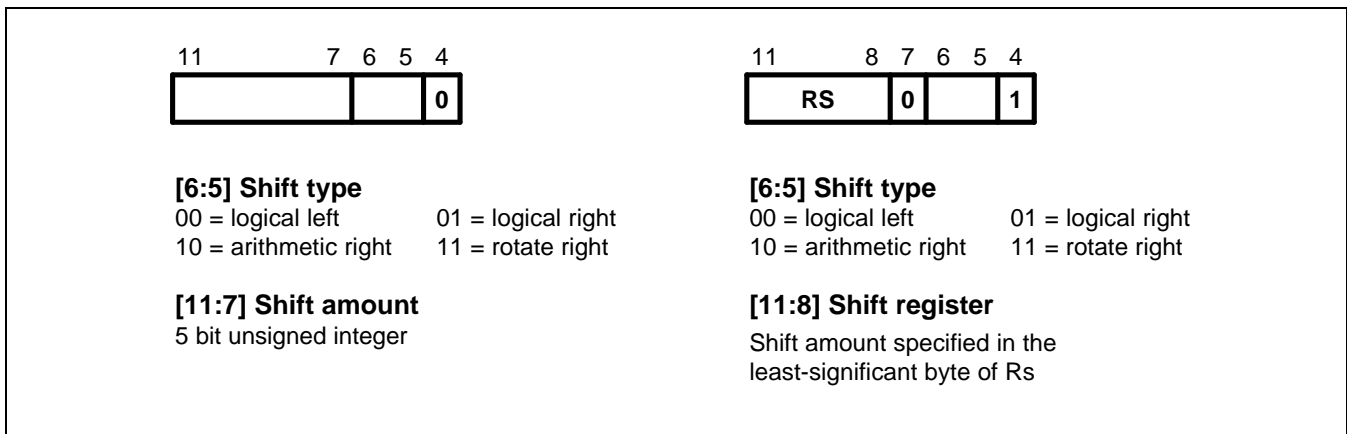

Figure 3-5. ARM Shift Operations

Instruction specified shift amount

When the shift amount is specified in the instruction, it is contained in a 5 bit field which may take any value from 0 to 31. A logical shift left (LSL) takes the contents of Rm and moves each bit by the specified amount to a more significant position. The least significant bits of the result are filled with zeros, and the high bits of Rm which do not map into the result are discarded, except that the least significant discarded bit becomes the shifter carry output which may be latched into the C bit of the CPSR when the ALU operation is in the logical class (see above). For example, the effect of LSL #5 is shown in Figure 3-6.

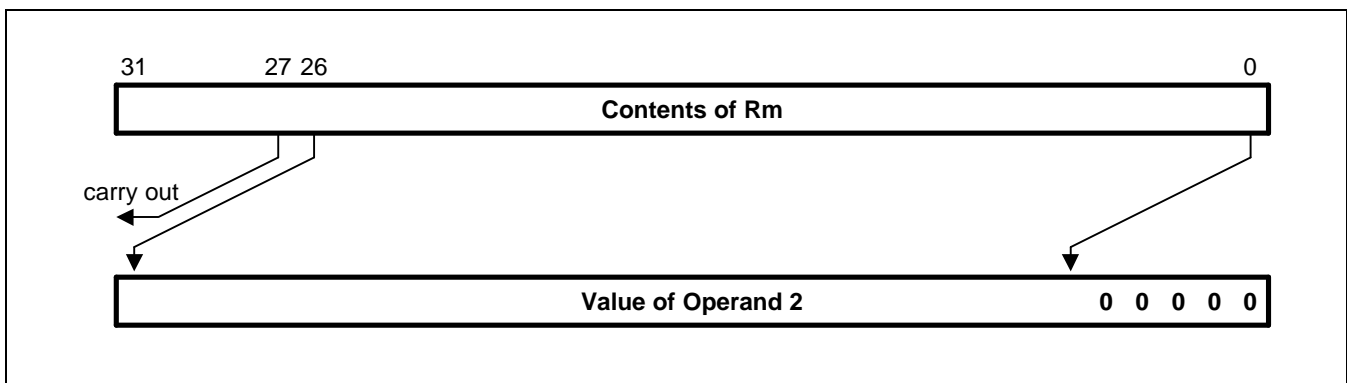

Figure 3-6. Logical Shift Left

NOTE

LSL #0 is a special case, where the shifter carry out is the old value of the CPSR C flag. The contents of Rm are used directly as the second operand. A logical shift right (LSR) is similar, but the contents of Rm are moved to less significant positions in the result. LSR #5 has the effect shown in Figure 3-7.

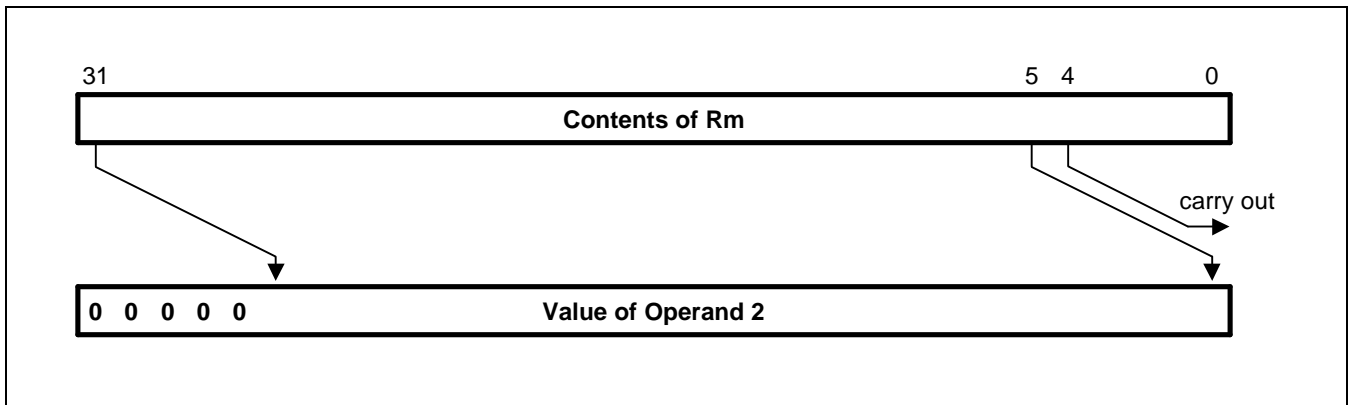

Figure 3-7. Logical Shift Right

The form of the shift field which might be expected to correspond to LSR #0 is used to encode LSR #32, which has a zero result with bit 31 of Rm as the carry output. Logical shift right zero is redundant as it is the same as logical shift left zero, so the assembler will convert LSR #0 (and ASR #0 and ROR #0) into LSL #0, and allow LSR #32 to be specified.

An arithmetic shift right (ASR) is similar to logical shift right, except that the high bits are filled with bit 31 of Rm instead of zeros. This preserves the sign in 2's complement notation. For example, ASR #5 is shown in Figure 3-8.

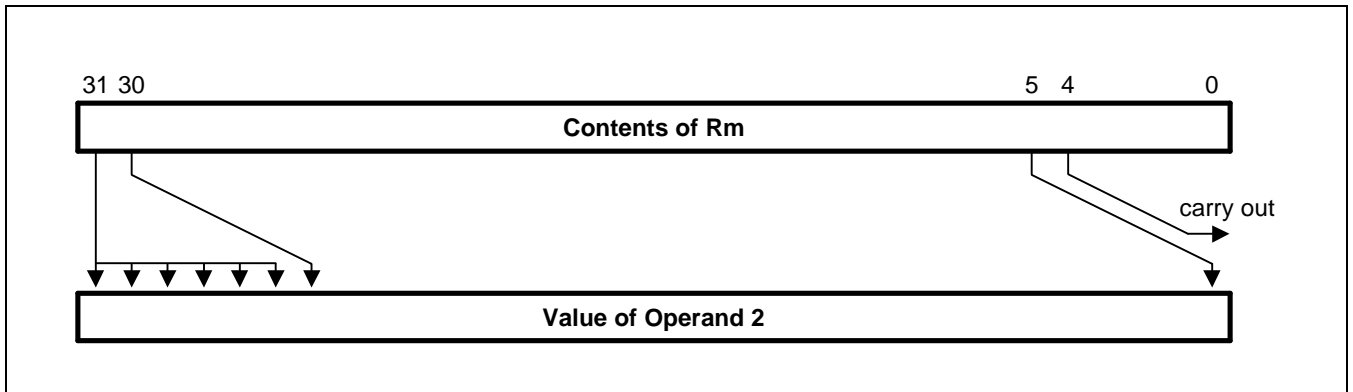

Figure 3-8. Arithmetic Shift Right

The form of the shift field which might be expected to give ASR #0 is used to encode ASR #32. Bit 31 of Rm is again used as the carry output, and each bit of operand 2 is also equal to bit 31 of Rm. The result is therefore all ones or all zeros, according to the value of bit 31 of Rm.

Rotate right (ROR) operations reuse the bits which "overshoot" in a logical shift right operation by reintroducing them at the high end of the result, in place of the zeros used to fill the high end in logical right operations. For example, ROR #5 is shown in Figure 3-9.

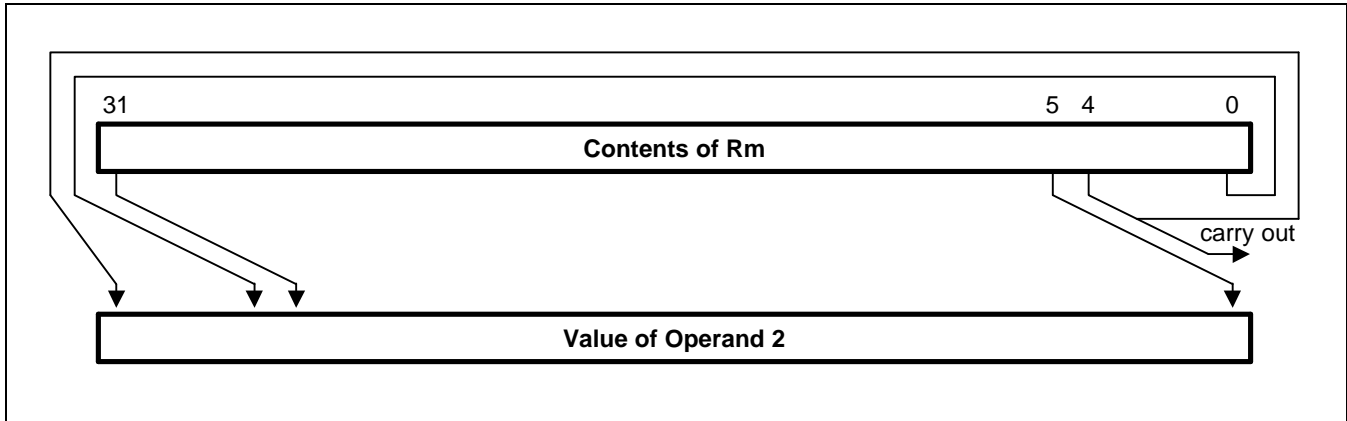

Figure 3-9. Rotate Right

The form of the shift field which might be expected to give ROR #0 is used to encode a special function of the barrel shifter, rotate right extended (RRX). This is a rotate right by one bit position of the 33 bit quantity formed by appending the CPSR C flag to the most significant end of the contents of Rm as shown in Figure 3-10.

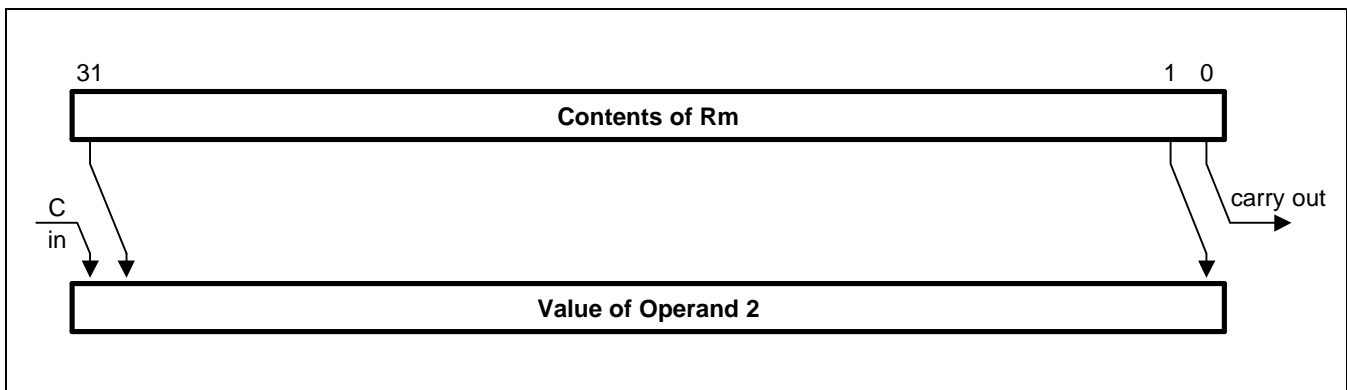

Figure 3-10. Rotate Right Extended

Register specified shift amount

Only the least significant byte of the contents of Rs is used to determine the shift amount. Rs can be any general register other than R15.

If this byte is zero, the unchanged contents of Rm will be used as the second operand, and the old value of the CPSR C flag will be passed on as the shifter carry output.

If the byte has a value between 1 and 31, the shifted result will exactly match that of an instruction specified shift with the same value and shift operation.

If the value in the byte is 32 or more, the result will be a logical extension of the shift described above:

1. LSL by 32 has result zero, carry out equal to bit 0 of Rm.
2. LSL by more than 32 has result zero, carry out zero.
3. LSR by 32 has result zero, carry out equal to bit 31 of Rm.
4. LSR by more than 32 has result zero, carry out zero.
5. ASR by 32 or more has result filled with the value of bit 31 of Rm, carry out equal to bit 31 of Rm.
6. ROR by 32 has result equal to Rm, carry out equal to bit 31 of Rm.
7. ROR by n where n is greater than 32 will give the same result and carry out as ROR by n-32; therefore repeatedly subtract 32 from n until the amount is in the range 1 to 32 and see above.

NOTE

The zero in bit 7 of an instruction with a register controlled shift is compulsory; a one in this bit will cause the instruction to be a multiply or undefined instruction.

IMMEDIATE OPERAND ROTATES

The immediate operand rotate field is a 4 bit unsigned integer which specifies a shift operation on the 8 bit immediate value. This value is zero extended to 32 bits, and then subject to a rotate right by twice the value in the rotate field. This enables many common constants to be generated, for example all powers of 2.

WRITING TO R15

When Rd is a register other than R15, the condition code flags in the CPSR may be updated from the ALU flags as described above.

When Rd is R15 and the S flag in the instruction is not set the result of the operation is placed in R15 and the CPSR is unaffected.

When Rd is R15 and the S flag is set the result of the operation is placed in R15 and the SPSR corresponding to the current mode is moved to the CPSR. This allows state changes which automatically restore both PC and CPSR. This form of instruction should not be used in User mode.

USING R15 AS AN OPERAND

If R15 (the PC) is used as an operand in a data processing instruction the register is used directly.

The PC value will be the address of the instruction, plus 8 or 12 bytes due to instruction pre-fetching. If the shift amount is specified in the instruction, the PC will be 8 bytes ahead. If a register is used to specify the shift amount the PC will be 12 bytes ahead.

TEQ, TST, CMP AND CMN OPCODES

NOTE

TEQ, TST, CMP and CMN do not write the result of their operation but do set flags in the CPSR. An assembler should always set the S flag for these instructions even if this is not specified in the mnemonic.

The TEQP form of the TEQ instruction used in earlier ARM processors must not be used: the PSR transfer operations should be used instead.

The action of TEQP in the ARM7TDMI is to move SPSR_<mode> to the CPSR if the processor is in a privileged mode and to do nothing if in User mode.

INSTRUCTION CYCLE TIMES

Data Processing instructions vary in the number of incremental cycles taken as follows:

Table 3-4. Incremental Cycle Times

Processing Type	Cycles
Normal data processing	1S
Data processing with register specified shift	1S + 1I
Data processing with PC written	2S + 1N
Data processing with register specified shift and PC written	2S + 1N + 1I

NOTE: S, N and I are as defined sequential (S-cycle), non-sequential (N-cycle), and internal (I-cycle) respectively.

ASSEMBLER SYNTAX

- MOV,MVN (single operand instructions).
<opcode>{cond}{S} Rd,<Op2>
- CMP,CMN,TEQ,TST (instructions which do not produce a result).
<opcode>{cond} Rn,<Op2>
- AND,EOR,SUB,RSB,ADD,ADC,SBC,RSC,ORR,BIC
<opcode>{cond}{S} Rd,Rn,<Op2>

where:

<Op2>	Rm{,<shift>} or,<#expression>
{cond}	A two-character condition mnemonic. See Table 3-2.
{S}	Set condition codes if S present (implied for CMP, CMN, TEQ, TST).
Rd, Rn and Rm	Expressions evaluating to a register number.
<#expression>	If this is used, the assembler will attempt to generate a shifted immediate 8-bit field to match the expression. If this is impossible, it will give an error.
<shift>	<Shiftname> <register> or <shiftname> #expression, or RRX (rotate right one bit with extend).
<shiftname>s	ASL, LSL, LSR, ASR, ROR. (ASL is a synonym for LSL, they assemble to the same code.)

EXAMPLES

ADDEQ	R2,R4,R5	; If the Z flag is set make R2:=R4+R5
TEQS	R4,#3	; Test R4 for equality with 3.
		; (The S is in fact redundant as the
		; assembler inserts it automatically.)
SUB	R4,R5,R7,LSR R2	; Logical right shift R7 by the number in
		; the bottom byte of R2, subtract result
		; from R5, and put the answer into R4.
MOV	PC,R14	; Return from subroutine.
MOVS	PC,R14	; Return from exception and restore CPSR
		; from SPSR_mode.

PSR TRANSFER (MRS, MSR)

The instruction is only executed if the condition is true. The various conditions are defined in Table 3-2.

The MRS and MSR instructions are formed from a subset of the Data Processing operations and are implemented using the TEQ, TST, CMN and CMP instructions without the S flag set. The encoding is shown in Figure 3-11.

These instructions allow access to the CPSR and SPSR registers. The MRS instruction allows the contents of the CPSR or SPSR_<mode> to be moved to a general register. The MSR instruction allows the contents of a general register to be moved to the CPSR or SPSR_<mode> register.

The MSR instruction also allows an immediate value or register contents to be transferred to the condition code flags (N,Z,C and V) of CPSR or SPSR_<mode> without affecting the control bits. In this case, the top four bits of the specified register contents or 32 bit immediate value are written to the top four bits of the relevant PSR.

OPERAND RESTRICTIONS

- In user mode, the control bits of the CPSR are protected from change, so only the condition code flags of the CPSR can be changed. In other (privileged) modes the entire CPSR can be changed.
- Note that the software must never change the state of the T bit in the CPSR. If this happens, the processor will enter an unpredictable state.
- The SPSR register which is accessed depends on the mode at the time of execution. For example, only SPSR_fiq is accessible when the processor is in FIQ mode.
- You must not specify R15 as the source or destination register.
- Also, do not attempt to access an SPSR in User mode, since no such register exists.

RESERVED BITS

Only twelve bits of the PSR are defined in ARM7TDMI (N,Z,C,V,I,F, T & M[4:0]); the remaining bits are reserved for use in future versions of the processor. Refer to Figure 2-6 for a full description of the PSR bits.

To ensure the maximum compatibility between ARM7TDMI programs and future processors, the following rules should be observed:

- The reserved bits should be preserved when changing the value in a PSR.
- Programs should not rely on specific values from the reserved bits when checking the PSR status, since they may read as one or zero in future processors.

A read-modify-write strategy should therefore be used when altering the control bits of any PSR register; this involves transferring the appropriate PSR register to a general register using the MRS instruction, changing only the relevant bits and then transferring the modified value back to the PSR register using the MSR instruction.

Examples

The following sequence performs a mode change:

```

MRS      R0,CPSR           ; Take a copy of the CPSR.
BIC      R0,R0,#0x1F      ; Clear the mode bits.
ORR      R0,R0,#new_mode  ; Select new mode
MSR      CPSR,R0          ; Write back the modified CPSR.

```

When the aim is simply to change the condition code flags in a PSR, a value can be written directly to the flag bits without disturbing the control bits. The following instruction sets the N,Z,C and V flags:

```

MSR      CPSR_flg,#0xF0000000 ; Set all the flags regardless of their previous state
                                           ; (does not affect any control bits).

```

No attempt should be made to write an 8 bit immediate value into the whole PSR since such an operation cannot preserve the reserved bits.

INSTRUCTION CYCLE TIMES

PSR transfers take 1S incremental cycles, where S is defined as Sequential (S-cycle).

ASSEMBLY SYNTAX

- MRS - transfer PSR contents to a register
MRS{cond} Rd,<psr>
- MSR - transfer register contents to PSR
MSR{cond} <psr>,Rm
- MSR - transfer register contents to PSR flag bits only
MSR{cond} <psrf>,Rm

The most significant four bits of the register contents are written to the N,Z,C & V flags respectively.

- MSR - transfer immediate value to PSR flag bits only
MSR{cond} <psrf>,<#expression>

The expression should symbolise a 32 bit value of which the most significant four bits are written to the N,Z,C and V flags respectively.

Key:

{cond}	Two-character condition mnemonic. See Table 3-2..
Rd and Rm	Expressions evaluating to a register number other than R15
<psr>	CPSR, CPSR_all, SPSR or SPSR_all. (CPSR and CPSR_all are synonyms as are SPSR and SPSR_all)
<psrf>	CPSR_flg or SPSR_flg
<#expression>	Where this is used, the assembler will attempt to generate a shifted immediate 8-bit field to match the expression. If this is impossible, it will give an error.

EXAMPLES

In User mode the instructions behave as follows:

```

MSR    CPSR_all,Rm          ; CPSR[31:28] ← Rm[31:28]
MSR    CPSR_flg,Rm         ; CPSR[31:28] ← Rm[31:28]
MSR    CPSR_flg,#0xA0000000 ; CPSR[31:28] ← 0xA (set N,C; clear Z,V)
MRS    Rd,CPSR             ; Rd[31:0] ← CPSR[31:0]

```

In privileged modes the instructions behave as follows:

```

MSR    CPSR_all,Rm          ; CPSR[31:0] ← Rm[31:0]
MSR    CPSR_flg,Rm         ; CPSR[31:28] ← Rm[31:28]
MSR    CPSR_flg,#0x50000000 ; CPSR[31:28] ← 0x5 (set Z,V; clear N,C)
MSR    SPSR_all,Rm         ; SPSR_<mode>[31:0] ← Rm[31:0]
MSR    SPSR_flg,Rm        ; SPSR_<mode>[31:28] ← Rm[31:28]
MSR    SPSR_flg,#0xC0000000 ; SPSR_<mode>[31:28] ← 0xC (set N,Z; clear C,V)
MRS    Rd,SPSR             ; Rd[31:0] ← SPSR_<mode>[31:0]

```

MULTIPLY AND MULTIPLY-ACCUMULATE (MUL, MLA)

The instruction is only executed if the condition is true. The various conditions are defined in Table 3-2. The instruction encoding is shown in Figure 3-12.

The multiply and multiply-accumulate instructions use an 8 bit Booth's algorithm to perform integer multiplication.

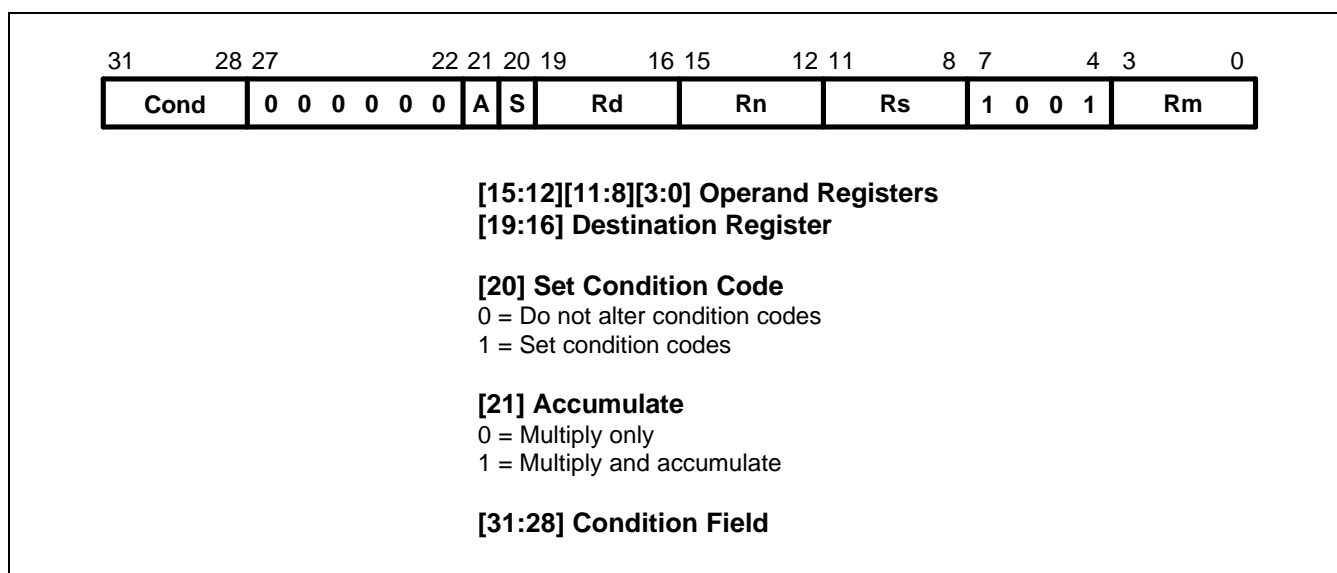

Figure 3-12. Multiply Instructions

The multiply form of the instruction gives $Rd=Rm \times Rs$. Rn is ignored, and should be set to zero for compatibility with possible future upgrades to the instruction set. The multiply-accumulate form gives $Rd=Rm \times Rs + Rn$, which can save an explicit ADD instruction in some circumstances. Both forms of the instruction work on operands which may be considered as signed (2's complement) or unsigned integers.

The results of a signed multiply and of an unsigned multiply of 32 bit operands differ only in the upper 32 bits - the low 32 bits of the signed and unsigned results are identical. As these instructions only produce the low 32 bits of a multiply, they can be used for both signed and unsigned multiplies.

For example consider the multiplication of the operands:

Operand A	Operand B	Result
0xFFFFFFFF6	0x0000001	0xFFFFFFFF38

If the Operands Are Interpreted as Signed

Operand A has the value -10, operand B has the value 20, and the result is -200 which is correctly represented as 0xFFFFFFFF38.

If the Operands Are Interpreted as Unsigned

Operand A has the value 4294967286, operand B has the value 20 and the result is 85899345720, which is represented as 0x13FFFFFF38, so the least significant 32 bits are 0xFFFFFFFF38.

Operand Restrictions

The destination register Rd must not be the same as the operand register Rm. R15 must not be used as an operand or as the destination register.

All other register combinations will give correct results, and Rd, Rn and Rs may use the same register when required.

CPSR FLAGS

Setting the CPSR flags is optional, and is controlled by the S bit in the instruction. The N (Negative) and Z (Zero) flags are set correctly on the result (N is made equal to bit 31 of the result, and Z is set if and only if the result is zero). The C (Carry) flag is set to a meaningless value and the V (oVerflow) flag is unaffected.

INSTRUCTION CYCLE TIMES

MUL takes $1S + mI$ and MLA $1S + (m+1)I$ cycles to execute, where S and I are defined as sequential (S-cycle) and internal (I-cycle), respectively.

m	The number of 8 bit multiplier array cycles is required to complete the multiply, which is controlled by the value of the multiplier operand specified by Rs. Its possible values are as follows
1	If bits [32:8] of the multiplier operand are all zero or all one.
2	If bits [32:16] of the multiplier operand are all zero or all one.
3	If bits [32:24] of the multiplier operand are all zero or all one.
4	In all other cases.

ASSEMBLER SYNTAX

MUL{cond}{S} Rd,Rm,Rs

MLA{cond}{S} Rd,Rm,Rs,Rn

{cond} Two-character condition mnemonic. See Table 3-2..

{S} Set condition codes if S present

Rd, Rm, Rs and Rn Expressions evaluating to a register number other than R15.

EXAMPLES

```
MUL      R1,R2,R3      ; R1:=R2*R3
MLAEQS   R1,R2,R3,R4  ; Conditionally R1:=R2*R3+R4, Setting condition codes.
```

MULTIPLY LONG AND MULTIPLY-ACCUMULATE LONG (MULL, MLAL)

The instruction is only executed if the condition is true. The various conditions are defined in Table 3-2. The instruction encoding is shown in Figure 3-13.

The multiply long instructions perform integer multiplication on two 32 bit operands and produce 64 bit results. Signed and unsigned multiplication each with optional accumulate give rise to four variations.

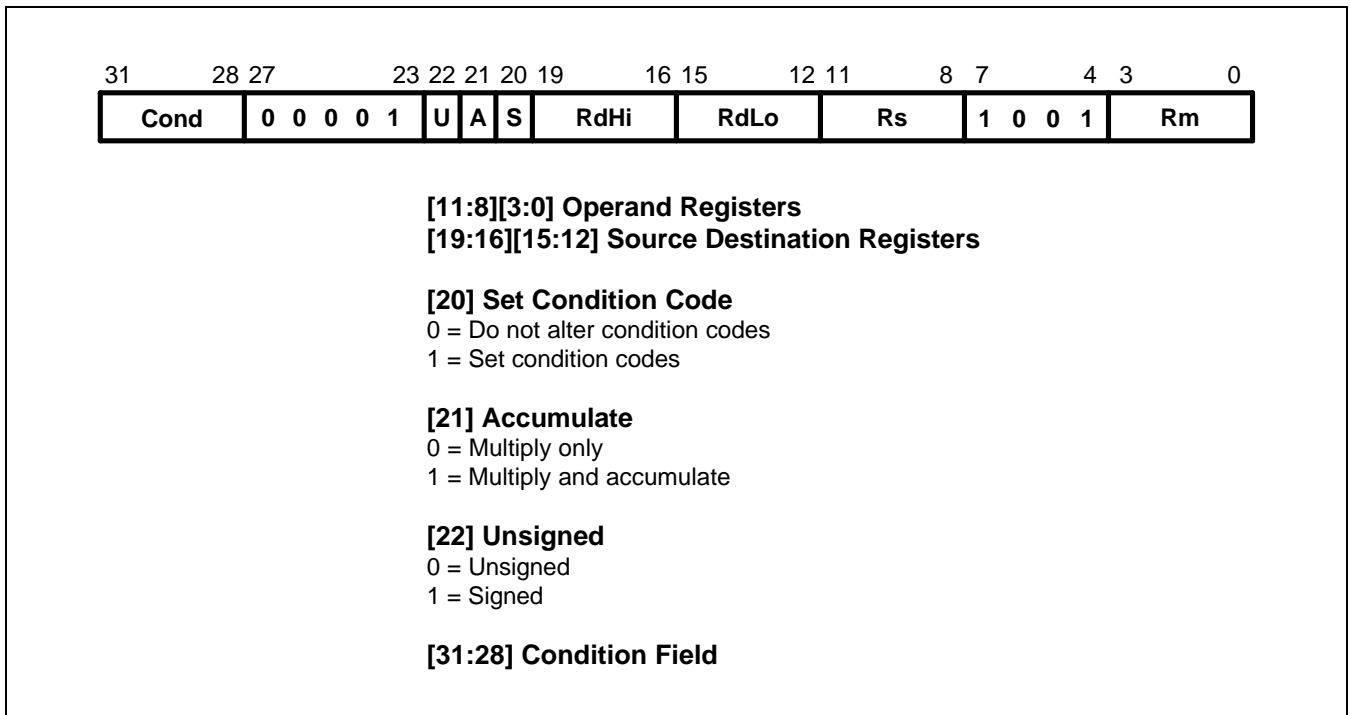

Figure 3-13. Multiply Long Instructions

The multiply forms (UMULL and SMULL) take two 32 bit numbers and multiply them to produce a 64 bit result of the form $RdHi, RdLo := Rm * Rs$. The lower 32 bits of the 64 bit result are written to RdLo, the upper 32 bits of the result are written to RdHi.

The multiply-accumulate forms (UMLAL and SMLAL) take two 32 bit numbers, multiply them and add a 64 bit number to produce a 64 bit result of the form $RdHi, RdLo := Rm * Rs + RdHi, RdLo$. The lower 32 bits of the 64 bit number to add is read from RdLo. The upper 32 bits of the 64 bit number to add is read from RdHi. The lower 32 bits of the 64 bit result are written to RdLo. The upper 32 bits of the 64 bit result are written to RdHi.

The UMULL and UMLAL instructions treat all of their operands as unsigned binary numbers and write an unsigned 64 bit result. The SMULL and SMLAL instructions treat all of their operands as two's-complement signed numbers and write a two's-complement signed 64 bit result.

OPERAND RESTRICTIONS

- R15 must not be used as an operand or as a destination register.
- RdHi, RdLo, and Rm must all specify different registers.

CPSR FLAGS

Setting the CPSR flags is optional, and is controlled by the S bit in the instruction. The N and Z flags are set correctly on the result (N is equal to bit 63 of the result, Z is set if and only if all 64 bits of the result are zero). Both the C and V flags are set to meaningless values.

INSTRUCTION CYCLE TIMES

MULL takes $1S + (m+1)I$ and MLAL $1S + (m+2)I$ cycles to execute, where m is the number of 8 bit multiplier array cycles required to complete the multiply, which is controlled by the value of the multiplier operand specified by Rs.

Its possible values are as follows:

For Signed INSTRUCTIONS SMULL, SMLAL:

- If bits [31:8] of the multiplier operand are all zero or all one.
- If bits [31:16] of the multiplier operand are all zero or all one.
- If bits [31:24] of the multiplier operand are all zero or all one.
- In all other cases.

For Unsigned Instructions UMULL, UMLAL:

- If bits [31:8] of the multiplier operand are all zero.
- If bits [31:16] of the multiplier operand are all zero.
- If bits [31:24] of the multiplier operand are all zero.
- In all other cases.

S and I are defined as sequential (S-cycle) and internal (I-cycle), respectively.

ASSEMBLER SYNTAX

Table 3-5. Assembler Syntax Descriptions

Mnemonic	Description	Purpose
UMULL{cond}{S} RdLo,RdHi,Rm,Rs	Unsigned Multiply Long	$32 \times 32 = 64$
UMLAL{cond}{S} RdLo,RdHi,Rm,Rs	Unsigned Multiply & Accumulate Long	$32 \times 32 + 64 = 64$
SMULL{cond}{S} RdLo,RdHi,Rm,Rs	Signed Multiply Long	$32 \times 32 = 64$
SMLAL{cond}{S} RdLo,RdHi,Rm,Rs	Signed Multiply & Accumulate Long	$32 \times 32 + 64 = 64$

where:

- {cond} Two-character condition mnemonic. See Table 3-2.
 {S} Set condition codes if S present
 RdLo, RdHi, Rm, Rs Expressions evaluating to a register number other than R15.

EXAMPLES

```
UMULL    R1,R4,R2,R3    ; R4,R1:=R2*R3
UMLALS   R1,R5,R2,R3    ; R5,R1:=R2*R3+R5,R1 also setting condition codes
```

OFFSETS AND AUTO-INDEXING

The offset from the base may be either a 12 bit unsigned binary immediate value in the instruction, or a second register (possibly shifted in some way). The offset may be added to (U=1) or subtracted from (U=0) the base register Rn. The offset modification may be performed either before (pre-indexed, P=1) or after (post-indexed, P=0) the base is used as the transfer address.

The W bit gives optional auto increment and decrement addressing modes. The modified base value may be written back into the base (W=1), or the old base value may be kept (W=0). In the case of post-indexed addressing, the write back bit is redundant and is always set to zero, since the old base value can be retained by setting the offset to zero. Therefore post-indexed data transfers always write back the modified base. The only use of the W bit in a post-indexed data transfer is in privileged mode code, where setting the W bit forces non-privileged mode for the transfer, allowing the operating system to generate a user address in a system where the memory management hardware makes suitable use of this hardware.

SHIFTED REGISTER OFFSET

The 8 shift control bits are described in the data processing instructions section. However, the register specified shift amounts are not available in this instruction class. See Figure 3-5.

BYTES AND WORDS

This instruction class may be used to transfer a byte (B=1) or a word (B=0) between an ARM7TDMI register and memory.

The action of LDR(B) and STR(B) instructions is influenced by the **BIGEND** control signal of ARM7TDMI core. The two possible configurations are described below.

Little-Endian Configuration

A byte load (LDRB) expects the data on data bus inputs 7 through 0 if the supplied address is on a word boundary, on data bus inputs 15 through 8 if it is a word address plus one byte, and so on. The selected byte is placed in the least significant 8 bits of the destination register, and the remaining bits of the register are filled with zeros. Please see Figure 2-2.

A byte store (STRB) repeats the least significant 8 bits of the source register four times across data bus outputs 31 through 0. The external memory system should activate the appropriate byte subsystem to store the data.

A word load (LDR) will normally use a word aligned address. However, an address offset from a word boundary will cause the data to be rotated into the register so that the addressed byte occupies bits 0 to 7. This means that half-words accessed at offsets 0 and 2 from the word boundary will be correctly loaded into bits 0 through 15 of the register. Two shift operations are then required to clear or to sign extend the upper 16 bits.

A word store (STR) should generate a word aligned address. The word presented to the data bus is not affected if the address is not word aligned. That is, bit 31 of the register being stored always appears on data bus output 31.

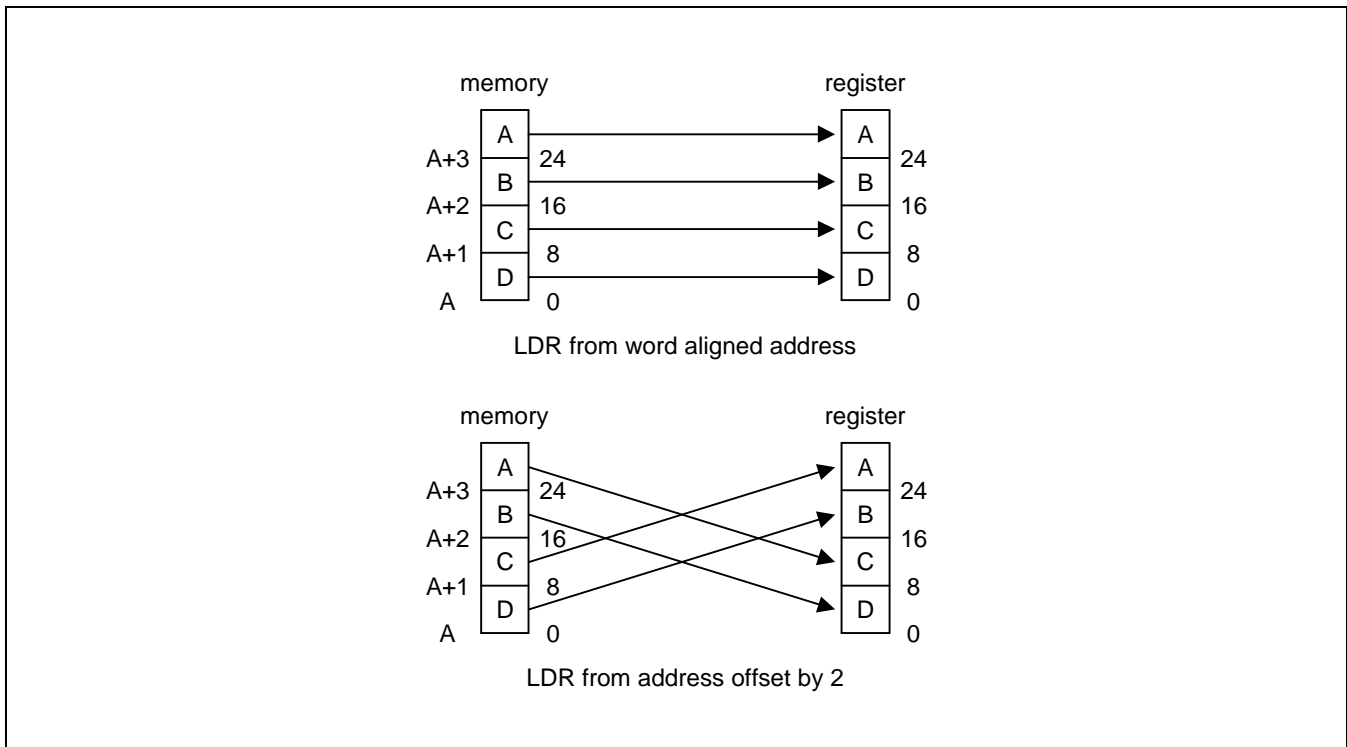

Figure 3-15. Little-Endian Offset Addressing

Big-Endian Configuration

A byte load (LDRB) expects the data on data bus inputs 31 through 24 if the supplied address is on a word boundary, on data bus inputs 23 through 16 if it is a word address plus one byte, and so on. The selected byte is placed in the least significant 8 bits of the destination register and the remaining bits of the register are filled with zeros. Please see Figure 2-1.

A byte store (STRB) repeats the least significant 8 bits of the source register four times across data bus outputs 31 through 0. The external memory system should activate the appropriate byte subsystem to store the data.

A word load (LDR) should generate a word aligned address. An address offset of 0 or 2 from a word boundary will cause the data to be rotated into the register so that the addressed byte occupies bits 31 through 24. This means that half-words accessed at these offsets will be correctly loaded into bits 16 through 31 of the register. A shift operation is then required to move (and optionally sign extend) the data into the bottom 16 bits. An address offset of 1 or 3 from a word boundary will cause the data to be rotated into the register so that the addressed byte occupies bits 15 through 8.

A word store (STR) should generate a word aligned address. The word presented to the data bus is not affected if the address is not word aligned. That is, bit 31 of the register being stored always appears on data bus output 31.

USE OF R15

Write-back must not be specified if R15 is specified as the base register (Rn). When using R15 as the base register you must remember it contains an address 8 bytes on from the address of the current instruction.

R15 must not be specified as the register offset (Rm).

When R15 is the source register (Rd) of a register store (STR) instruction, the stored value will be address of the instruction plus 12.

RESTRICTION ON THE USE OF BASE REGISTER

When configured for late aborts, the following example code is difficult to unwind as the base register, Rn, gets updated before the abort handler starts. Sometimes it may be impossible to calculate the initial value.

After an abort, the following example code is difficult to unwind as the base register, Rn, gets updated before the abort handler starts. Sometimes it may be impossible to calculate the initial value.

Example:

```
LDR    R0,[R1],R1
```

Therefore a post-indexed LDR or STR where Rm is the same register as Rn should not be used.

DATA ABORTS

A transfer to or from a legal address may cause problems for a memory management system. For instance, in a system which uses virtual memory the required data may be absent from main memory. The memory manager can signal a problem by taking the processor ABORT input HIGH whereupon the Data Abort trap will be taken. It is up to the system software to resolve the cause of the problem, then the instruction can be restarted and the original program continued.

INSTRUCTION CYCLE TIMES

Normal LDR instructions take $1S + 1N + 1I$ and LDR PC take $2S + 2N + 1I$ incremental cycles, where S,N and I are defined as sequential (S-cycle), non-sequential (N-cycle), and internal (I-cycle), respectively. STR instructions take $2N$ incremental cycles to execute.

ASSEMBLER SYNTAX

<LDR|STR>{cond}{B}{T} Rd,<Address>

where:

LDR	Load from memory into a register
STR	Store from a register into memory
{cond}	Two-character condition mnemonic. See Table 3-2.
{B}	If B is present then byte transfer, otherwise word transfer
{T}	If T is present the W bit will be set in a post-indexed instruction, forcing non-privileged mode for the transfer cycle. T is not allowed when a pre-indexed addressing mode is specified or implied.
Rd	An expression evaluating to a valid register number.
Rn and Rm	Expressions evaluating to a register number. If Rn is R15 then the assembler will subtract 8 from the offset value to allow for ARM7TDMI pipelining. In this case base write-back should not be specified.

<Address>can be:

1	An expression which generates an address: The assembler will attempt to generate an instruction using the PC as a base and a corrected immediate offset to address the location given by evaluating the expression. This will be a PC relative, pre-indexed address. If the address is out of range, an error will be generated.
2	A pre-indexed addressing specification: [Rn] offset of zero [Rn,<#expression>]{!} offset of <expression> bytes [Rn,{+/-}Rm{,<shift>}]!} offset of +/- contents of index register, shifted by <shift>
3	A post-indexed addressing specification: [Rn],<#expression> offset of <expression> bytes [Rn,{+/-}Rm{,<shift>} offset of +/- contents of index register, shifted as by <shift>.
<shift>	General shift operation (see data processing instructions) but you cannot specify the shift amount by a register.
{!}	Writes back the base register (set the W bit) if! is present.

EXAMPLES

STR	R1,[R2,R4]!	; Store R1 at R2+R4 (both of which are registers) ; and write back address to R2.
STR	R1,[R2],R4	; Store R1 at R2 and write back R2+R4 to R2.
LDR	R1,[R2,#16]	; Load R1 from contents of R2+16, but don't write back.
LDR	R1,[R2,R3,LSL#2]	; Load R1 from contents of R2+R3*4.
LDREQB	R1,[R6,#5]	; Conditionally load byte at R6+5 into ; R1 bits 0 to 7, filling bits 8 to 31 with zeros.
STR	R1,PLACE	; Generate PC relative offset to address PLACE.
PLACE		

HALFWORD AND SIGNED BYTE DATA TRANSFER (LDRH/STRH/LDRSB/LDRSH)

The instruction is only executed if the condition is true. The various conditions are defined in Table 3-2. The instruction encoding is shown in Figure 3-16.

These instructions are used to load or store half-words of data and also load sign-extended bytes. The memory address used in the transfer is calculated by adding an offset to or subtracting an offset from a base register. The result of this calculation may be written back into the base register if auto-indexing is required.

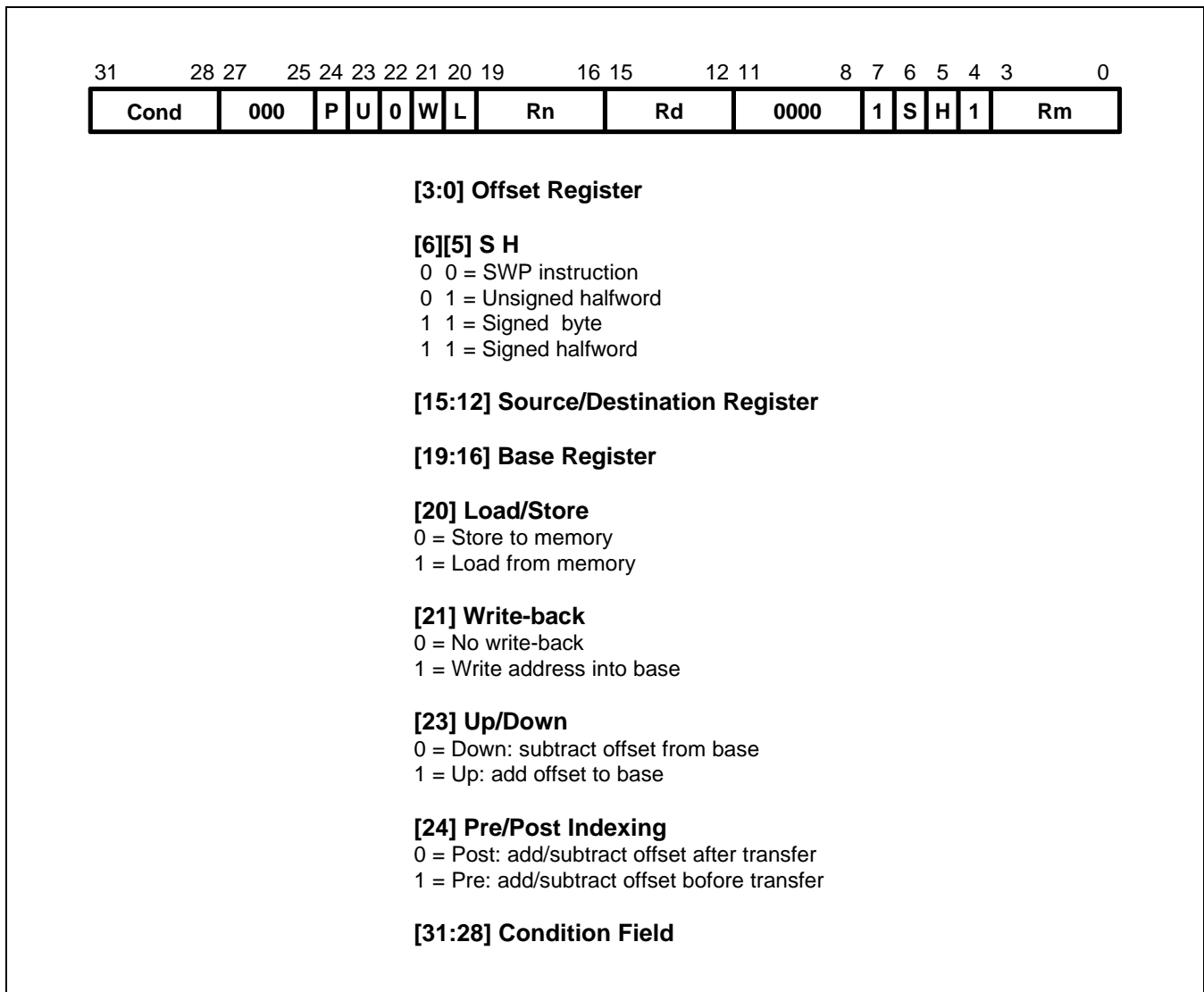

Figure 3-16. Half-word and Signed Byte Data Transfer with Register Offset

HALF-WORD LOAD AND STORES

Setting S=0 and H=1 may be used to transfer unsigned Half-words between an ARM7TDMI register and memory.

The action of LDRH and STRH instructions is influenced by the BIGEND control signal. The two possible configurations are described in the section below.

SIGNED BYTE AND HALF-WORD LOADS

The S bit controls the loading of sign-extended data. When S=1 the H bit selects between Bytes (H=0) and Half-words (H=1). The L bit should not be set low (Store) when Signed (S=1) operations have been selected.

The LDRSB instruction loads the selected Byte into bits 7 to 0 of the destination register and bits 31 to 8 of the destination register are set to the value of bit 7, the sign bit.

The LDRSH instruction loads the selected Half-word into bits 15 to 0 of the destination register and bits 31 to 16 of the destination register are set to the value of bit 15, the sign bit.

The action of the LDRSB and LDRSH instructions is influenced by the BIGEND control signal. The two possible configurations are described in the following section.

ENDIANNESS AND BYTE/HALF-WORD SELECTION

Little-Endian Configuration

A signed byte load (LDRSB) expects data on data bus inputs 7 through to 0 if the supplied address is on a word boundary, on data bus inputs 15 through to 8 if it is a word address plus one byte, and so on. The selected byte is placed in the bottom 8 bit of the destination register, and the remaining bits of the register are filled with the sign bit, bit 7 of the byte. Please see Figure 2-2.

A half-word load (LDRSH or LDRH) expects data on data bus inputs 15 through to 0 if the supplied address is on a word boundary and on data bus inputs 31 through to 16 if it is a half-word boundary, (A[1]=1). The supplied address should always be on a half-word boundary. If bit 0 of the supplied address is HIGH then the ARM7TDMI will load an unpredictable value. The selected half-word is placed in the bottom 16 bits of the destination register. For unsigned half-words (LDRH), the top 16 bits of the register are filled with zeros and for signed half-words (LDRSH) the top 16 bits are filled with the sign bit, bit 15 of the half-word.

A half-word store (STRH) repeats the bottom 16 bits of the source register twice across the data bus outputs 31 through to 0. The external memory system should activate the appropriate half-word subsystem to store the data. Note that the address must be half-word aligned, if bit 0 of the address is HIGH this will cause unpredictable behavior.

Big-Endian Configuration

A signed byte load (LDRSB) expects data on data bus inputs 31 through to 24 if the supplied address is on a word boundary, on data bus inputs 23 through to 16 if it is a word address plus one byte, and so on. The selected byte is placed in the bottom 8 bit of the destination register, and the remaining bits of the register are filled with the sign bit, bit 7 of the byte. Please see Figure 2-1.

A half-word load (LDRSH or LDRH) expects data on data bus inputs 31 through to 16 if the supplied address is on a word boundary and on data bus inputs 15 through to 0 if it is a half-word boundary, (A[1]=1). The supplied address should always be on a half-word boundary. If bit 0 of the supplied address is HIGH then the ARM7TDMI will load an unpredictable value. The selected half-word is placed in the bottom 16 bits of the destination register. For unsigned half-words (LDRH), the top 16 bits of the register are filled with zeros and for signed half-words (LDRSH) the top 16 bits are filled with the sign bit, bit 15 of the half-word.

A half-word store (STRH) repeats the bottom 16 bits of the source register twice across the data bus outputs 31 through to 0. The external memory system should activate the appropriate half-word subsystem to store the data. Note that the address must be half-word aligned, if bit 0 of the address is HIGH this will cause unpredictable behavior.

USE OF R15

Write-back should not be specified if R15 is specified as the base register (Rn). When using R15 as the base register you must remember it contains an address 8 bytes on from the address of the current instruction.

R15 should not be specified as the register offset (Rm).

When R15 is the source register (Rd) of a Half-word store (STRH) instruction, the stored address will be address of the instruction plus 12.

DATA ABORTS

A transfer to or from a legal address may cause problems for a memory management system. For instance, in a system which uses virtual memory the required data may be absent from the main memory. The memory manager can signal a problem by taking the processor ABORT input HIGH whereupon the Data Abort trap will be taken. It is up to the system software to resolve the cause of the problem, then the instruction can be restarted and the original program continued.

INSTRUCTION CYCLE TIMES

Normal LDR(H,SH,SB) instructions take $1S + 1N + 1I$. LDR(H,SH,SB) PC take $2S + 2N + 1I$ incremental cycles. S,N and I are defined as sequential (S-cycle), non-sequential (N-cycle), and internal (I-cycle), respectively. STRH instructions take $2N$ incremental cycles to execute.

ASSEMBLER SYNTAX

<LDR|STR>{cond}<H|SH|SB> Rd,<address>

LDR	Load from memory into a register
STR	Store from a register into memory
{cond}	Two-character condition mnemonic. See Table 3-2..
H	Transfer half-word quantity
SB	Load sign extended byte (Only valid for LDR)
SH	Load sign extended half-word (Only valid for LDR)
Rd	An expression evaluating to a valid register number.

<address> can be:

- 1 An expression which generates an address:
The assembler will attempt to generate an instruction using the PC as a base and a corrected immediate offset to address the location given by evaluating the expression. This will be a PC relative, pre-indexed address. If the address is out of range, an error will be generated.
 - 2 A pre-indexed addressing specification:

[Rn]	offset of zero
[Rn,<#expression>]{!}	offset of <expression> bytes
[Rn,{+/-}Rm]{!}	offset of +/- contents of index register
 - 3 A post-indexed addressing specification:

[Rn,<#expression>	offset of <expression> bytes
[Rn,{+/-}Rm	offset of +/- contents of index register.
 - 4 Rn and Rm are expressions evaluating to a register number. If Rn is R15 then the assembler will subtract 8 from the offset value to allow for ARM7TDMI pipelining. In this case base write-back should not be specified.
- {!} Writes back the base register (set the W bit) if ! is present.

EXAMPLES

LDRH	R1,[R2,-R3]!	; Load R1 from the contents of the half-word address ; contained in R2-R3 (both of which are registers) ; and write back address to R2
STRH	R3,[R4,#14]	; Store the half-word in R3 at R14+14 but don't write back.
LDRSB	R8,[R2],#-223	; Load R8 with the sign extended contents of the byte ; address contained in R2 and write back R2-223 to R2.
LDRNESH	R11,[R0]	; Conditionally load R11 with the sign extended contents ; of the half-word address contained in R0.
HERE		; Generate PC relative offset to address FRED.
STRH	R5, [PC,#(FRED-HERE-8)];	Store the half-word in R5 at address FRED
FRED		

ADDRESSING MODES

The transfer addresses are determined by the contents of the base register (Rn), the pre/post bit (P) and the up/down bit (U). The registers are transferred in the order lowest to highest, so R15 (if in the list) will always be transferred last. The lowest register also gets transferred to/from the lowest memory address. By way of illustration, consider the transfer of R1, R5 and R7 in the case where Rn=0x1000 and write back of the modified base is required (W=1). Figure 3.19-22 show the sequence of register transfers, the addresses used, and the value of Rn after the instruction has completed.

In all cases, had write back of the modified base not been required (W=0), Rn would have retained its initial value of 0x1000 unless it was also in the transfer list of a load multiple register instruction, when it would have been overwritten with the loaded value.

ADDRESS ALIGNMENT

The address should normally be a word aligned quantity and non-word aligned addresses do not affect the instruction. However, the bottom 2 bits of the address will appear on **A[1:0]** and might be interpreted by the memory system.

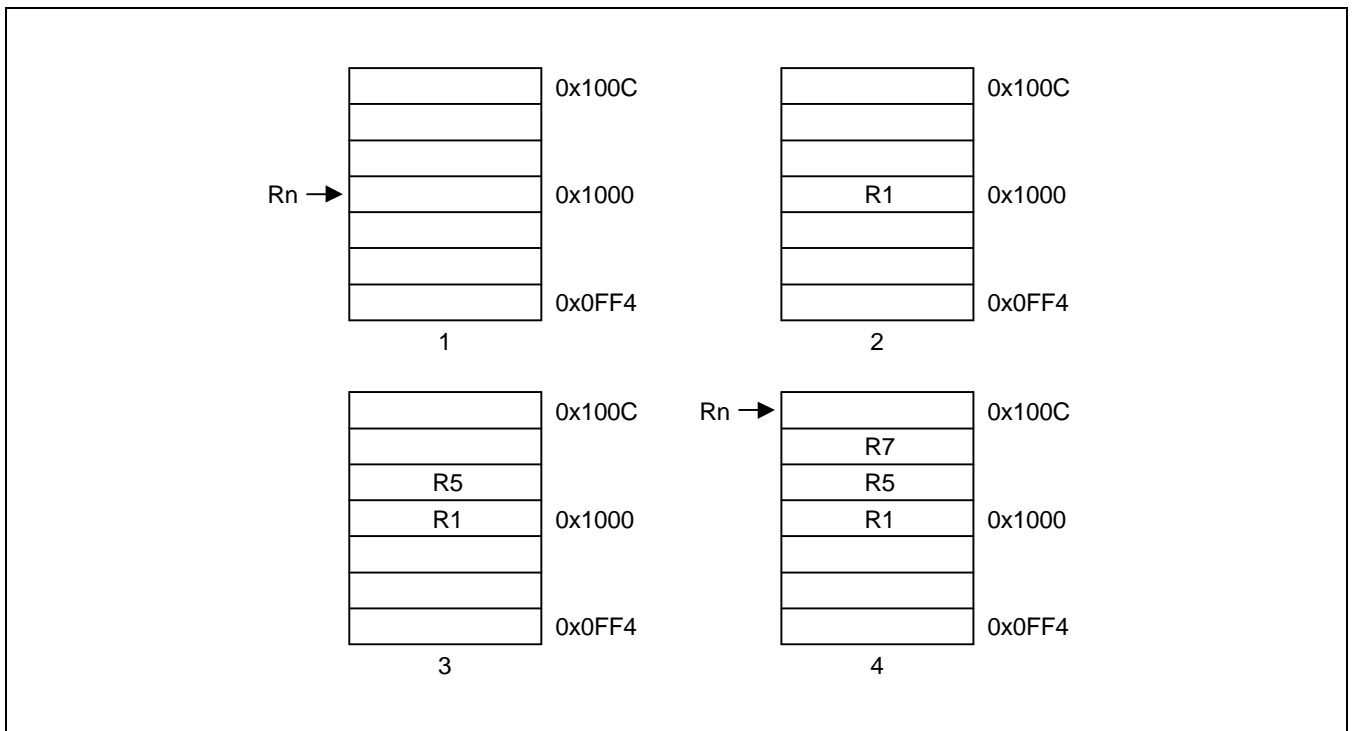

Figure 3-19. Post-Increment Addressing

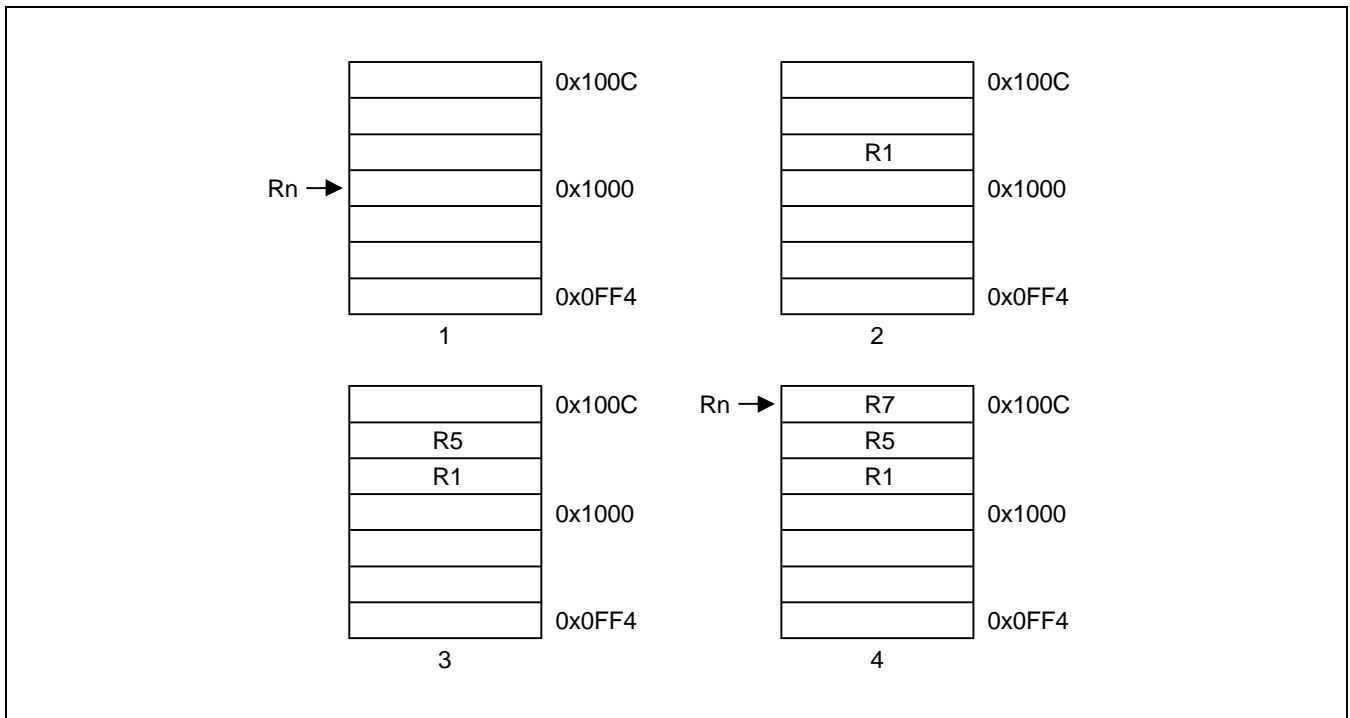

Figure 3-20. Pre-Increment Addressing

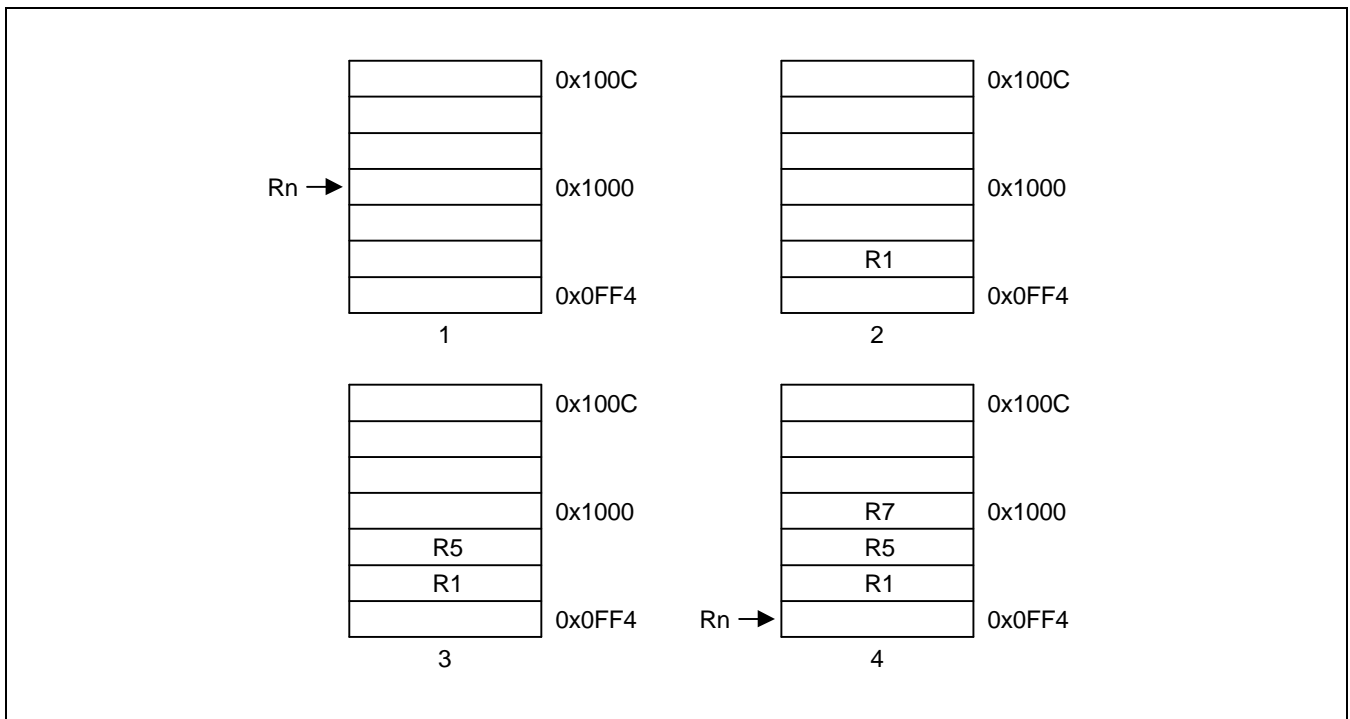

Figure 3-21. Post-Decrement Addressing

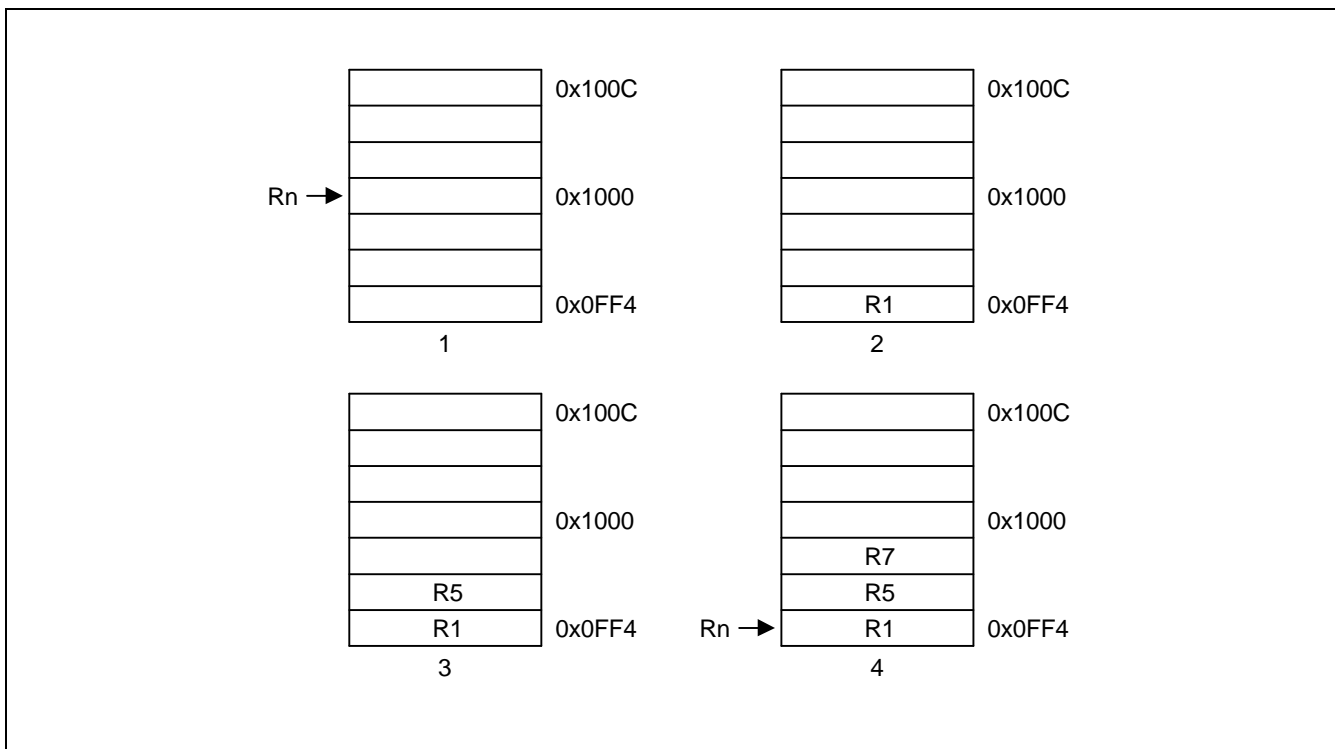

Figure 3-22. Pre-Decrement Addressing

USE OF THE S BIT

When the S bit is set in a LDM/STM instruction its meaning depends on whether or not R15 is in the transfer list and on the type of instruction. The S bit should only be set if the instruction is to execute in a privileged mode.

LDM with R15 in Transfer List and S Bit Set (Mode Changes)

If the instruction is a LDM then SPSR_<mode> is transferred to CPSR at the same time as R15 is loaded.

STM with R15 in Transfer List and S Bit Set (User Bank Transfer)

The registers transferred are taken from the User bank rather than the bank corresponding to the current mode. This is useful for saving the user state on process switches. Base write-back should not be used when this mechanism is employed.

R15 not in List and S Bit Set (User Bank Transfer)

For both LDM and STM instructions, the User bank registers are transferred rather than the register bank corresponding to the current mode. This is useful for saving the user state on process switches. Base write-back should not be used when this mechanism is employed.

When the instruction is LDM, care must be taken not to read from a banked register during the following cycle (inserting a dummy instruction such as MOV R0, R0 after the LDM will ensure safety).

USE OF R15 AS THE BASE

R15 should not be used as the base register in any LDM or STM instruction.

INCLUSION OF THE BASE IN THE REGISTER LIST

When write-back is specified, the base is written back at the end of the second cycle of the instruction. During a STM, the first register is written out at the start of the second cycle. A STM which includes storing the base, with the base as the first register to be stored, will therefore store the unchanged value, whereas with the base second or later in the transfer order, will store the modified value. A LDM will always overwrite the updated base if the base is in the list.

DATA ABORTS

Some legal addresses may be unacceptable to a memory management system, and the memory manager can indicate a problem with an address by taking the **ABORT** signal HIGH. This can happen on any transfer during a multiple register load or store, and must be recoverable if ARM7TDMI is to be used in a virtual memory system.

Abort during STM Instructions

If the abort occurs during a store multiple instruction, ARM7TDMI takes little action until the instruction completes, whereupon it enters the data abort trap. The memory manager is responsible for preventing erroneous writes to the memory. The only change to the internal state of the processor will be the modification of the base register if write-back was specified, and this must be reversed by software (and the cause of the abort resolved) before the instruction may be retried.

Aborts during LDM Instructions

When ARM7TDMI detects a data abort during a load multiple instruction, it modifies the operation of the instruction to ensure that recovery is possible.

- Overwriting of registers stops when the abort happens. The aborting load will not take place but earlier ones may have overwritten registers. The PC is always the last register to be written and so will always be preserved.
- The base register is restored, to its modified value if write-back was requested. This ensures recoverability in the case where the base register is also in the transfer list, and may have been overwritten before the abort occurred.

The data abort trap is taken when the load multiple has completed, and the system software must undo any base modification (and resolve the cause of the abort) before restarting the instruction.

INSTRUCTION CYCLE TIMES

Normal LDM instructions take $nS + 1N + 1I$ and LDM PC takes $(n+1)S + 2N + 1I$ incremental cycles, where S,N and I are defined as sequential (S-cycle), non-sequential (N-cycle), and internal (I-cycle), respectively. STM instructions take $(n-1)S + 2N$ incremental cycles to execute, where n is the number of words transferred.

ASSEMBLER SYNTAX

<LDM|STM>{cond}<FD|ED|FA|EA|IA|IB|DA|DB> Rn{!},<Rlist>{^}

where:

{cond}	Two character condition mnemonic. See Table 3-2.
Rn	An expression evaluating to a valid register number
<Rlist>	A list of registers and register ranges enclosed in {} (e.g. {R0,R2-R7,R10}).
{!}	If present requests write-back (W=1), otherwise W=0.
{^}	If present set S bit to load the CPSR along with the PC, or force transfer of user bank when in privileged mode.

Addressing Mode Names

There are different assembler mnemonics for each of the addressing modes, depending on whether the instruction is being used to support stacks or for other purposes. The equivalence between the names and the values of the bits in the instruction are shown in the following table 3-6.

Table 3-6. Addressing Mode Names

Name	Stack	Other	L bit	P bit	U bit
Pre-Increment Load	LDMED	LDMIB	1	1	1
Post-Increment Load	LDMFD	LDMIA	1	0	1
Pre-Decrement Load	LDMEA	LDMDB	1	1	0
Post-Decrement Load	LDMFA	LDMDA	1	0	0
Pre-Increment Store	STMFA	STMIB	0	1	1
Post-Increment Store	STMEA	STMIA	0	0	1
Pre-Decrement Store	STMFD	STMDB	0	1	0
Post-Decrement Store	STMED	STMDA	0	0	0

FD, ED, FA, EA define pre/post indexing and the up/down bit by reference to the form of stack required. The F and E refer to a "full" or "empty" stack, i.e. whether a pre-index has to be done (full) before storing to the stack. The A and D refer to whether the stack is ascending or descending. If ascending, a STM will go up and LDM down, if descending, vice-versa.

IA, IB, DA, DB allow control when LDM/STM are not being used for stacks and simply mean Increment After, Increment Before, Decrement After, Decrement Before.

EXAMPLES

```
LDMFD    SP!,{R0,R1,R2}    ; Unstack 3 registers.
STMIA    R0,{R0-R15}      ; Save all registers.
LDMFD    SP!,{R15}        ; R15 ← (SP), CPSR unchanged.
LDMFD    SP!,{R15}^       ; R15 ← (SP), CPSR ← SPSR_mode
                                     ; (allowed only in privileged modes).
STMFD    R13,{R0-R14}^    ; Save user mode regs on stack
                                     ; (allowed only in privileged modes).
```

These instructions may be used to save state on subroutine entry, and restore it efficiently on return to the calling routine:

```
STMED    SP!,{R0-R3,R14}  ; Save R0 to R3 to use as workspace
                                     ; and R14 for returning.
BL       somewhere        ; This nested call will overwrite R14
LDMED    SP!,{R0-R3,R15}  ; Restore workspace and return.
```

SINGLE DATA SWAP (SWP)

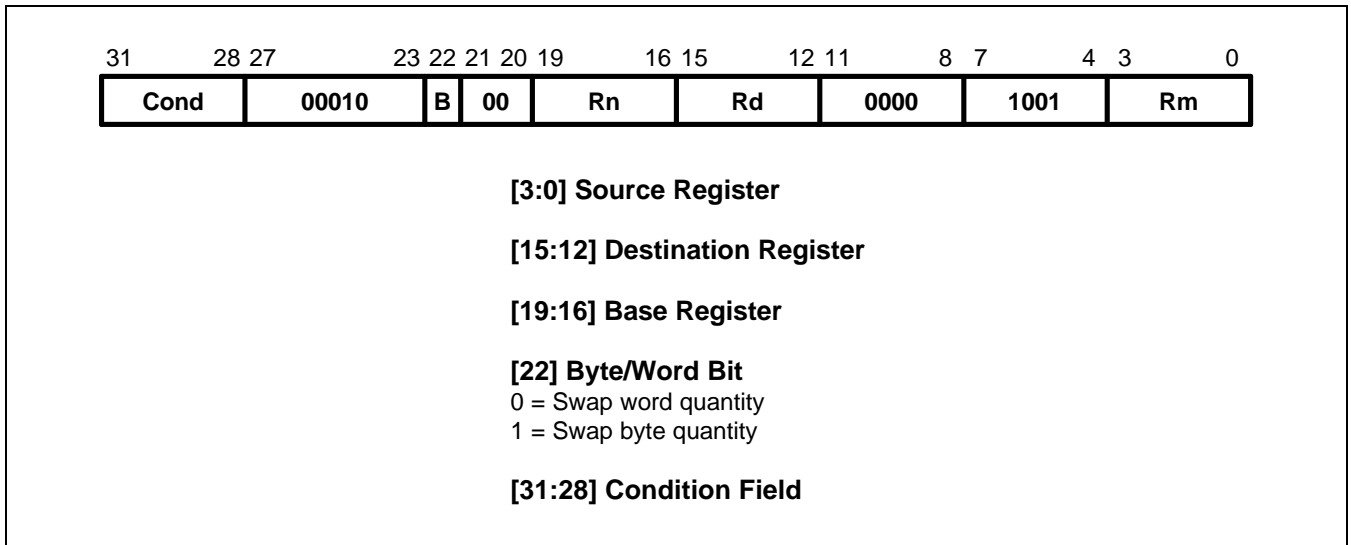

Figure 3-23. Swap Instruction

The instruction is only executed if the condition is true. The various conditions are defined in Table 3-2. The instruction encoding is shown in Figure 3-23.

The data swap instruction is used to swap a byte or word quantity between a register and external memory. This instruction is implemented as a memory read followed by a memory write which are “locked” together (the processor cannot be interrupted until both operations have completed, and the memory manager is warned to treat them as inseparable). This class of instruction is particularly useful for implementing software semaphores.

The swap address is determined by the contents of the base register (Rn). The processor first reads the contents of the swap address. Then it writes the contents of the source register (Rm) to the swap address, and stores the old memory contents in the destination register (Rd). The same register may be specified as both the source and destination.

The **LOCK** output goes HIGH for the duration of the read and write operations to signal to the external memory manager that they are locked together, and should be allowed to complete without interruption. This is important in multi-processor systems where the swap instruction is the only indivisible instruction which may be used to implement semaphores; control of the memory must not be removed from a processor while it is performing a locked operation.

BYTES AND WORDS

This instruction class may be used to swap a byte (B=1) or a word (B=0) between an ARM7TDMI register and memory. The SWP instruction is implemented as a LDR followed by a STR and the action of these is as described in the section on single data transfers. In particular, the description of Big and Little Endian configuration applies to the SWP instruction.

USE OF R15

Do not use R15 as an operand (Rd, Rn or Rs) in a SWP instruction.

DATA ABORTS

If the address used for the swap is unacceptable to a memory management system, the memory manager can flag the problem by driving ABORT HIGH. This can happen on either the read or the write cycle (or both), and in either case, the Data Abort trap will be taken. It is up to the system software to resolve the cause of the problem, then the instruction can be restarted and the original program continued.

INSTRUCTION CYCLE TIMES

Swap instructions take $1S + 2N + 1I$ incremental cycles to execute, where S,N and I are defined as sequential (S-cycle), non-sequential, and internal (I-cycle), respectively.

ASSEMBLER SYNTAX

<SWP>{cond}{B} Rd,Rm,[Rn]

{cond} Two-character condition mnemonic. See Table 3-2.
 {B} If B is present then byte transfer, otherwise word transfer
 Rd,Rm,Rn Expressions evaluating to valid register numbers

EXAMPLES

SWP	R0,R1,[R2]	; Load R0 with the word addressed by R2, and ; store R1 at R2.
SWPB	R2,R3,[R4]	; Load R2 with the byte addressed by R4, and ; store bits 0 to 7 of R3 at R4.
SWPEQ	R0,R0,[R1]	; Conditionally swap the contents of the ; word addressed by R1 with R0.

SOFTWARE INTERRUPT (SWI)

The instruction is only executed if the condition is true. The various conditions are defined in Table 3-2. The instruction encoding is shown in Figure 3-24, below.

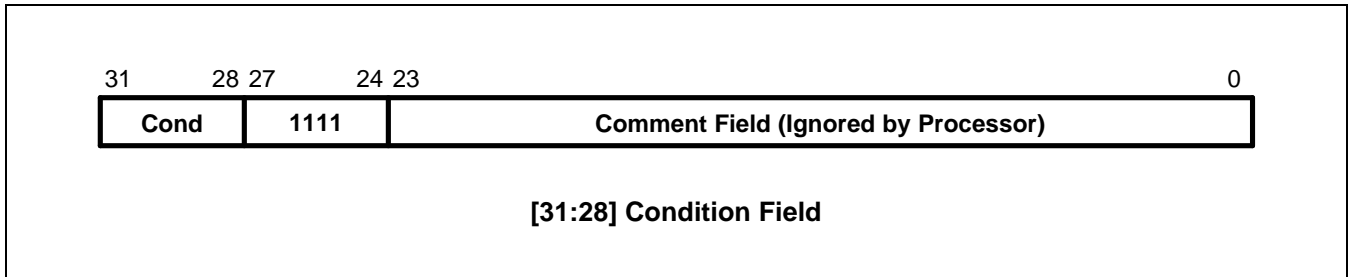

Figure 3-24. Software Interrupt Instruction

The software interrupt instruction is used to enter Supervisor mode in a controlled manner. The instruction causes the software interrupt trap to be taken, which effects the mode change. The PC is then forced to a fixed value (0x08) and the CPSR is saved in SPSR_svc. If the SWI vector address is suitably protected (by external memory management hardware) from modification by the user, a fully protected operating system may be constructed.

RETURN FROM THE SUPERVISOR

The PC is saved in R14_svc upon entering the software interrupt trap, with the PC adjusted to point to the word after the SWI instruction. MOVS PC,R14_svc will return to the calling program and restore the CPSR.

Note that the link mechanism is not re-entrant, so if the supervisor code wishes to use software interrupts within itself it must first save a copy of the return address and SPSR.

COMMENT FIELD

The bottom 24 bits of the instruction are ignored by the processor, and may be used to communicate information to the supervisor code. For instance, the supervisor may look at this field and use it to index into an array of entry points for routines which perform the various supervisor functions.

INSTRUCTION CYCLE TIMES

Software interrupt instructions take $2S + 1N$ incremental cycles to execute, where S and N are defined as sequential (S-cycle) and non-sequential (N-cycle).

ASSEMBLER SYNTAX

SWI{cond} <expression>

{cond} Two character condition mnemonic, Table 3-2.
 <expression> Evaluated and placed in the comment field (which is ignored by ARM7TDMI).

EXAMPLES

```

SWI      ReadC           ; Get next character from read stream.
SWI      Writel+"k"     ; Output a "k" to the write stream.
SWINE    0               ; Conditionally call supervisor with 0 in comment field.

```

Supervisor code

The previous examples assume that suitable supervisor code exists, for instance:

```

0x08 B Supervisor      ; SWI entry point
EntryTable             ; Addresses of supervisor routines
DCD ZeroRtn
DCD ReadCRtn
DCD WritelRtn
...
Zero      EQU 0
ReadC     EQU 256
Writel    EQU 512

Supervisor             ; SWI has routine required in bits 8-23 and data (if any) in
                       ; bits 0-7. Assumes R13_svc points to a suitable stack
STMFD     R13,{R0-R2,R14} ; Save work registers and return address.
LDR       R0,[R14,#-4]    ; Get SWI instruction.
BIC       R0,R0,#0xFF000000 ; Clear top 8 bits.
MOV       R1,R0,LSR#8     ; Get routine offset.
ADR       R2,EntryTable  ; Get start address of entry table.
LDR       R15,[R2,R1,LSL#2] ; Branch to appropriate routine.
WritelRtn ; Enter with character in R0 bits 0-7.
...
LDMFD     R13,{R0-R2,R15}^ ; Restore workspace and return,
                           ; restoring processor mode and flags.

```

COPROCESSOR DATA OPERATIONS (CDP)

The instruction is only executed if the condition is true. The various conditions are defined in Table 3-2. The instruction encoding is shown in Figure 3-25.

This class of instruction is used to tell a coprocessor to perform some internal operation. No result is communicated back to ARM7TDMI, and it will not wait for the operation to complete. The coprocessor could contain a queue of such instructions awaiting execution, and their execution can overlap other activity, allowing the coprocessor and ARM7TDMI to perform independent tasks in parallel.

COPROCESSOR INSTRUCTIONS

The S3F443FX, unlike some other ARM-based processors, does not have an external coprocessor interface. It does not have a on-chip coprocessor also.

So then all coprocessor instructions will cause the undefined instruction trap to be taken on the S3F443FX. These coprocessor instructions can be emulated by the undefined trap handler. Even though external coprocessor can not be connected to the S3F443FX, the coprocessor instructions are still described here in full for completeness. (Remember that any external coprocessor described in this section is a software emulation.)

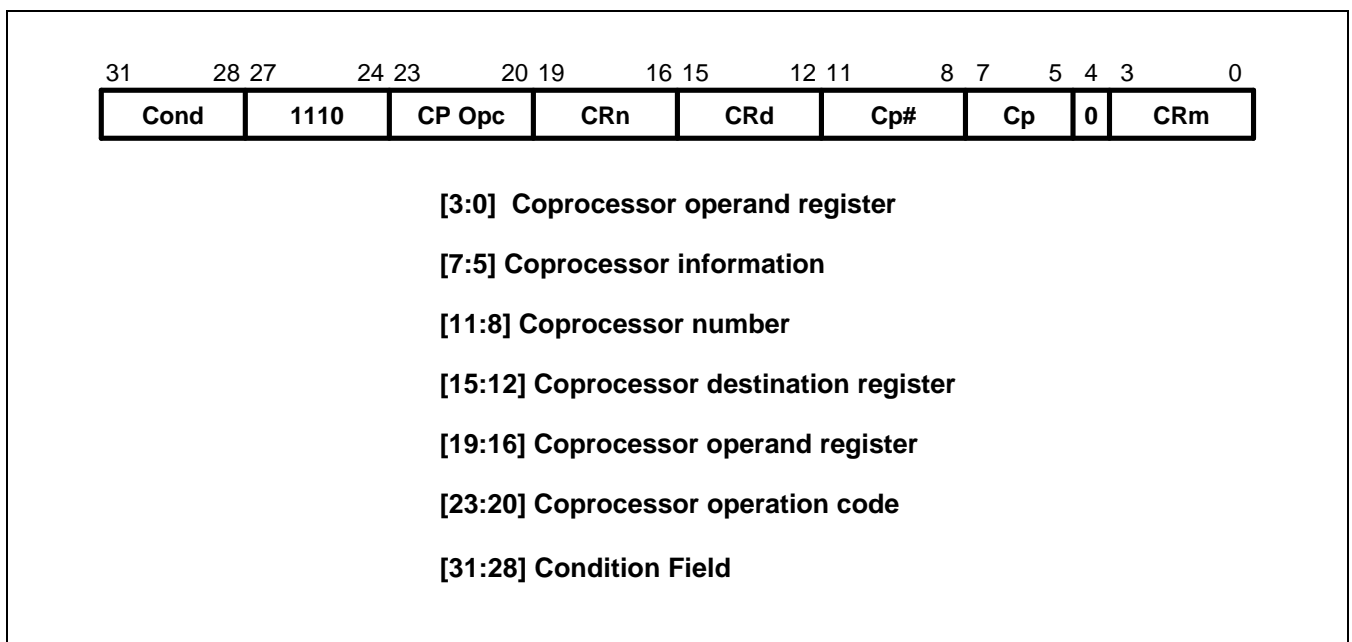

Figure 3-25. Coprocessor Data Operation Instruction

Only bit 4 and bits 24 to 31 The coprocessor fields are significant to ARM7TDMI. The remaining bits are used by coprocessors. The above field names are used by convention, and particular coprocessors may redefine the use of all fields except CP# as appropriate. The CP# field is used to contain an identifying number (in the range 0 to 15) for each coprocessor, and a coprocessor will ignore any instruction which does not contain its number in the CP# field.

The conventional interpretation of the instruction is that the coprocessor should perform an operation specified in the CP Opc field (and possibly in the CP field) on the contents of CRn and CRm, and place the result in CRd.

INSTRUCTION CYCLE TIMES

Coprocessor data operations take $1S + bI$ incremental cycles to execute, where b is the number of cycles spent in the coprocessor busy-wait loop.

S and I are defined as sequential (S-cycle) and internal (I-cycle).

ASSEMBLER SYNTAX

CDP{cond} p#,<expression1>,cd,cn,cm{,<expression2>}

{cond}	Two character condition mnemonic. See Table 3-2.
p#	The unique number of the required coprocessor
<expression1>	Evaluated to a constant and placed in the CP Opc field
cd, cn and cm	Evaluate to the valid coprocessor register numbers CRd, CRn and CRm respectively
<expression2>	Where present is evaluated to a constant and placed in the CP field

EXAMPLES

CDP	p1,10,c1,c2,c3	; Request coprocessor 1 to do operation 10
		; on CR2 and CR3, and put the result in CR1.
CDPEQ	p2,5,c1,c2,c3,2	; If Z flag is set request coprocessor 2 to do operation 5
		; (type 2)
		; on CR2 and CR3, and put the result in CR1.

COPROCESSOR DATA TRANSFERS (LDC, STC)

The instruction is only executed if the condition is true. The various conditions are defined in Table 3-2. The instruction encoding is shown in Figure 3-26.

This class of instruction is used to load (LDC) or store (STC) a subset of a coprocessor's registers directly to memory. ARM7TDMI is responsible for supplying the memory address, and the coprocessor supplies or accepts the data and controls the number of words transferred.

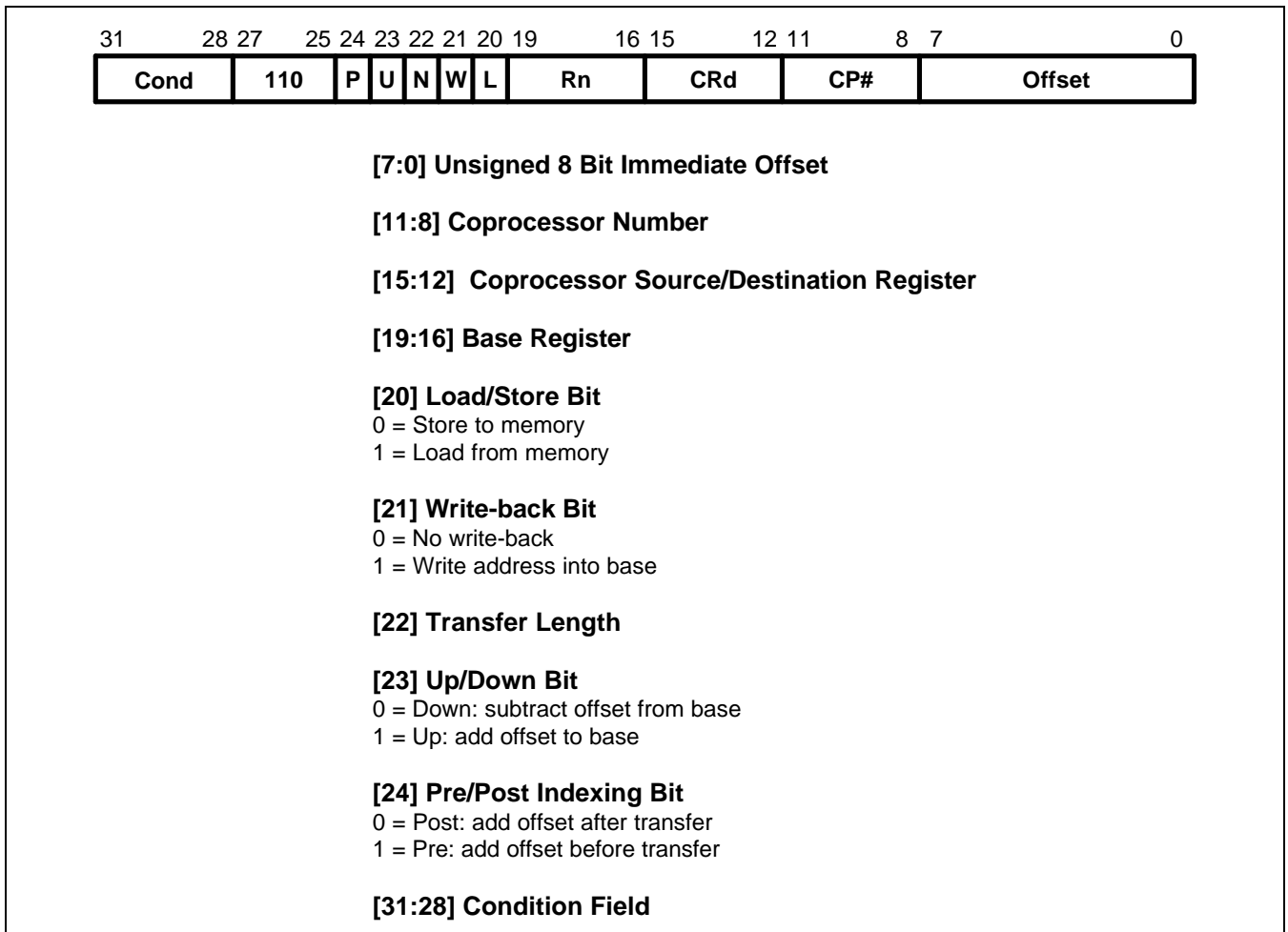

Figure 3-26. Coprocessor Data Transfer Instructions

THE COPROCESSOR FIELDS

The CP# field is used to identify the coprocessor which is required to supply or accept the data, and a coprocessor will only respond if its number matches the contents of this field.

The CRd field and the N bit contain information for the coprocessor which may be interpreted in different ways by different coprocessors, but by convention CRd is the register to be transferred (or the first register where more than one is to be transferred), and the N bit is used to choose one of two transfer length options. For instance N=0 could select the transfer of a single register, and N=1 could select the transfer of all the registers for context switching.

ADDRESSING MODES

ARM7TDMI is responsible for providing the address used by the memory system for the transfer, and the addressing modes available are a subset of those used in single data transfer instructions. Note, however, that the immediate offsets are 8 bits wide and specify word offsets for coprocessor data transfers, whereas they are 12 bits wide and specify byte offsets for single data transfers.

The 8 bit unsigned immediate offset is shifted left 2 bits and either added to (U=1) or subtracted from (U=0) the base register (Rn); this calculation may be performed either before (P=1) or after (P=0) the base is used as the transfer address. The modified base value may be overwritten back into the base register (if W=1), or the old value of the base may be preserved (W=0). Note that post-indexed addressing modes require explicit setting of the W bit, unlike LDR and STR which always write-back when post-indexed.

The value of the base register, modified by the offset in a pre-indexed instruction, is used as the address for the transfer of the first word. The second word (if more than one is transferred) will go to or come from an address one word (4 bytes) higher than the first transfer, and the address will be incremented by one word for each subsequent transfer.

ADDRESS ALIGNMENT

The base address should normally be a word aligned quantity. The bottom 2 bits of the address will appear on **A[1:0]** and might be interpreted by the memory system.

USE OF R15

If Rn is R15, the value used will be the address of the instruction plus 8 bytes. Base write-back to R15 must not be specified.

DATA ABORTS

If the address is legal but the memory manager generates an abort, the data trap will be taken. The write-back of the modified base will take place, but all other processor state will be preserved. The coprocessor is partly responsible for ensuring that the data transfer can be restarted after the cause of the abort has been resolved, and must ensure that any subsequent actions it undertakes can be repeated when the instruction is retried.

INSTRUCTION CYCLE TIMES

Coprocessor data transfer instructions take $(n-1)S + 2N + bI$ incremental cycles to execute, where:

- n The number of words transferred.
- b The number of cycles spent in the coprocessor busy-wait loop.

S, N and I are defined as sequential (S-cycle), non-sequential (N-cycle), and internal (I-cycle), respectively.

ASSEMBLER SYNTAX

<LDC|STC>{cond}{L} p#,cd,<Address>

LDC	Load from memory to coprocessor
STC	Store from coprocessor to memory
{L}	When present perform long transfer (N=1), otherwise perform short transfer (N=0)
{cond}	Two character condition mnemonic. See Table 3-2..
p#	The unique number of the required coprocessor
cd	An expression evaluating to a valid coprocessor register number that is placed in the CRd field
<Address>	can be:
1	An expression which generates an address: The assembler will attempt to generate an instruction using the PC as a base and a corrected immediate offset to address the location given by evaluating the expression. This will be a PC relative, pre-indexed address. If the address is out of range, an error will be generated
2	A pre-indexed addressing specification: [Rn] offset of zero [Rn,<#expression>]{!} offset of <expression> bytes
3	A post-indexed addressing specification: [Rn],<#expression> offset of <expression> bytes {!} write back the base register (set the W bit) if ! is present Rn is an expression evaluating to a valid ARM7TDMI register number.

NOTE

If Rn is R15, the assembler will subtract 8 from the offset value to allow for ARM7TDMI pipelining.

EXAMPLES

LDC	p1,c2,table	; Load c2 of coprocessor 1 from address
		; table, using a PC relative address.
STCEQL	p2,c3,[R5,#24]!	; Conditionally store c3 of coprocessor 2
		; into an address 24 bytes up from R5,
		; write this address back to R5, and use
		; long transfer option (probably to store multiple words).

NOTE

Although the address offset is expressed in bytes, the instruction offset field is in words. The assembler will adjust the offset appropriately.

COPROCESSOR REGISTER TRANSFERS (MRC, MCR)

The instruction is only executed if the condition is true. The various conditions are defined in Table 3-2. The instruction encoding is shown in Figure 3-27.

This class of instruction is used to communicate information directly between ARM7TDMI and a coprocessor. An example of a coprocessor to ARM7TDMI register transfer (MRC) instruction would be a FIX of a floating point value held in a coprocessor, where the floating point number is converted into a 32 bit integer within the coprocessor, and the result is then transferred to ARM7TDMI register. A FLOAT of a 32 bit value in ARM7TDMI register into a floating point value within the coprocessor illustrates the use of ARM7TDMI register to coprocessor transfer (MCR).

An important use of this instruction is to communicate control information directly from the coprocessor into the ARM7TDMI CPSR flags. As an example, the result of a comparison of two floating point values within a coprocessor can be moved to the CPSR to control the subsequent flow of execution.

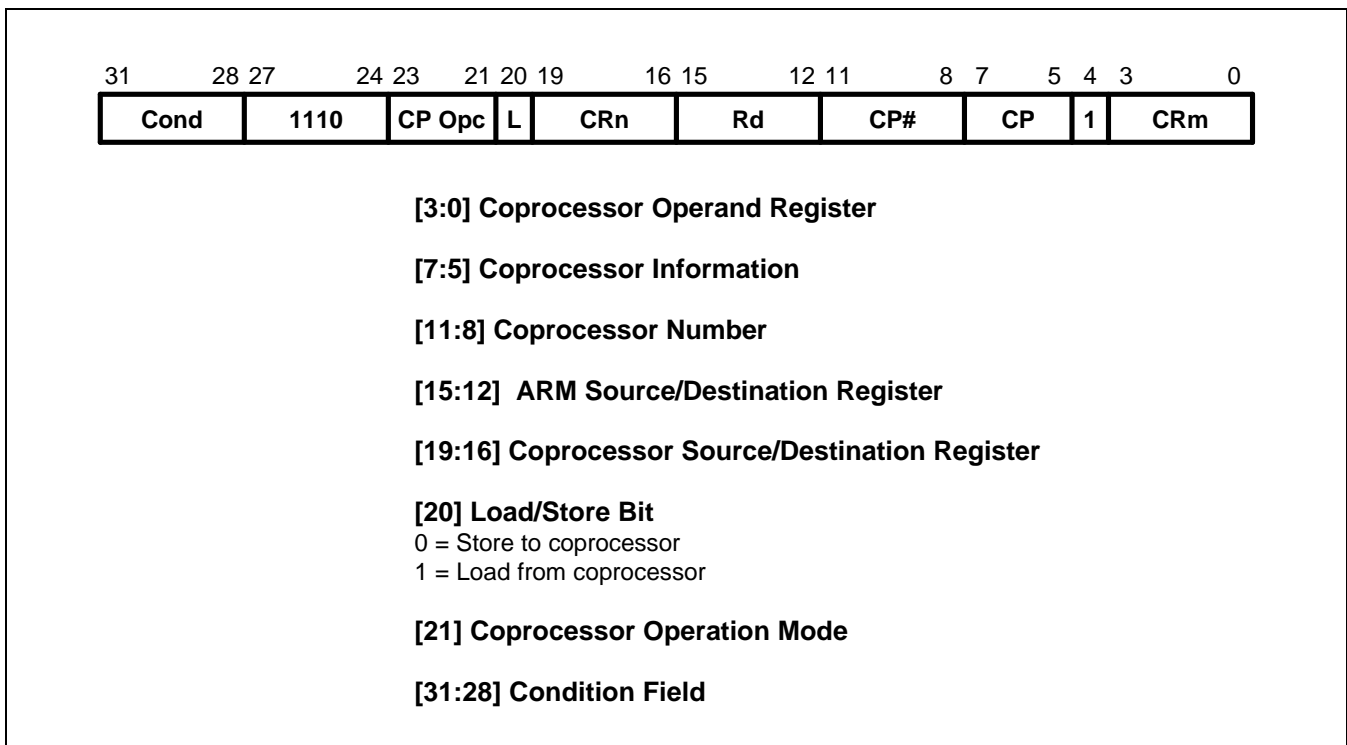

Figure 3-27. Coprocessor Register Transfer Instructions

THE COPROCESSOR FIELDS

The CP# field is used, as for all coprocessor instructions, to specify which coprocessor is being called upon.

The CP Opc, CRn, CP and CRm fields are used only by the coprocessor, and the interpretation presented here is derived from convention only. Other interpretations are allowed where the coprocessor functionality is incompatible with this one. The conventional interpretation is that the CP Opc and CP fields specify the operation the coprocessor is required to perform, CRn is the coprocessor register which is the source or destination of the transferred information, and CRm is a second coprocessor register which may be involved in some way which depends on the particular operation specified.

TRANSFERS TO R15

When a coprocessor register transfer to ARM7TDMI has R15 as the destination, bits 31, 30, 29 and 28 of the transferred word are copied into the N, Z, C and V flags respectively. The other bits of the transferred word are ignored, and the PC and other CPSR bits are unaffected by the transfer.

TRANSFERS FROM R15

A coprocessor register transfer from ARM7TDMI with R15 as the source register will store the PC+12.

INSTRUCTION CYCLE TIMES

MRC instructions take $1S + (b+1)I + 1C$ incremental cycles to execute, where S, I and C are defined as sequential (S-cycle), internal (I-cycle), and coprocessor register transfer (C-cycle), respectively. MCR instructions take $1S + bI + 1C$ incremental cycles to execute, where b is the number of cycles spent in the coprocessor busy-wait loop.

ASSEMBLER SYNTAX

<MCR|MRC>{cond} p#,<expression1>,Rd,cn,cm{,<expression2>}

MRC	Move from coprocessor to ARM7TDMI register (L=1)
MCR	Move from ARM7TDMI register to coprocessor (L=0)
{cond}	Two character condition mnemonic. See Table 3-2
p#	The unique number of the required coprocessor
<expression1>	Evaluated to a constant and placed in the CP Opc field
Rd	An expression evaluating to a valid ARM7TDMI register number
cn and cm	Expressions evaluating to the valid coprocessor register numbers CRn and CRm respectively
<expression2>	Where present is evaluated to a constant and placed in the CP field

EXAMPLES

MRC	p2,5,R3,c5,c6	; Request coprocessor 2 to perform operation 5 ; on c5 and c6, and transfer the (single ; 32-bit word) result back to R3.
MCR	p6,0,R4,c5,c6	; Request coprocessor 6 to perform operation 0 ; on R4 and place the result in c6.
MRCEQ	p3,9,R3,c5,c6,2	; Conditionally request coprocessor 3 to ; perform operation 9 (type 2) on c5 and ; c6, and transfer the result back to R3.

UNDEFINED INSTRUCTION

The instruction is only executed if the condition is true. The various conditions are defined in Table 3-2. The instruction format is shown in Figure 3-28.

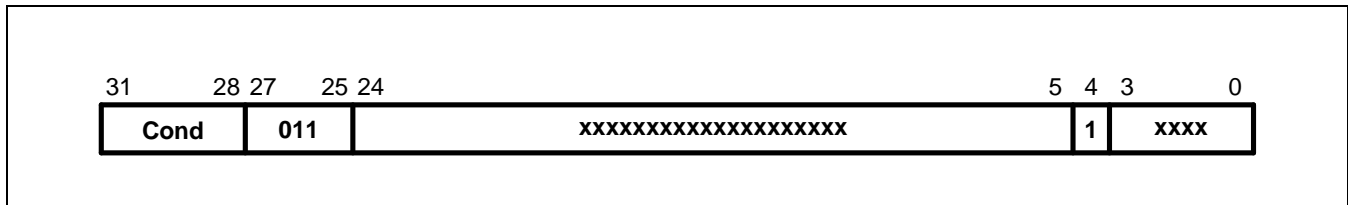

Figure 3-28. Undefined Instruction

If the condition is true, the undefined instruction trap will be taken.

Note that the undefined instruction mechanism involves offering this instruction to any coprocessors which may be present, and all coprocessors must refuse to accept it by driving **CPA** and **CPB** HIGH.

INSTRUCTION CYCLE TIMES

This instruction takes $2S + 1I + 1N$ cycles, where S, N and I are defined as sequential (S-cycle), non-sequential (N-cycle), and internal (I-cycle).

ASSEMBLER SYNTAX

The assembler has no mnemonics for generating this instruction. If it is adopted in the future for some specified use, suitable mnemonics will be added to the assembler. Until such time, this instruction must not be used.

INSTRUCTION SET EXAMPLES

The following examples show ways in which the basic ARM7TDMI instructions can combine to give efficient code. None of these methods saves a great deal of execution time (although they may save some), mostly they just save code.

USING THE CONDITIONAL INSTRUCTIONS

Using Conditionals for Logical OR

```

CMP      Rn,#p          ; If Rn=p OR Rm=q THEN GOTO Label.
BEQ      Label
CMP      Rm,#q
BEQ      Label

```

This can be replaced by

```

CMP      Rn,#p
CMPNE   Rm,#q          ; If condition not satisfied try other test.
BEQ      Label

```

Absolute Value

```

TEQ      Rn,#0          ; Test sign
RSBMI   Rn,Rn,#0       ; and 2's complement if necessary.

```

Multiplication by 4, 5 or 6 (Run Time)

```

MOV      Rc,Ra,LSL#2   ; Multiply by 4,
CMP      Rb,#5         ; Test value,
ADDCS   Rc,Rc,Ra       ; Complete multiply by 5,
ADDHI   Rc,Rc,Ra       ; Complete multiply by 6.

```

Combining Discrete and Range Tests

```

TEQ      Rc,#127       ; Discrete test,
CMPNE   Rc,#"-1       ; Range test
MOVLS   Rc,#"         ; IF Rc<=" OR Rc=ASCII(127)
                          ; THEN Rc="."

```

Division and Remainder

A number of divide routines for specific applications are provided in source form as part of the ANSI C library provided with the ARM Cross Development Toolkit, available from your supplier. A short general purpose divide routine follows.

			; Enter with numbers in Ra and Rb.
	MOV	Rcnt,#1	; Bit to control the division.
Div1	CMP	Rb,#0x80000000	; Move Rb until greater than Ra.
	CMPCC	Rb,Ra	
	MOVCC	Rb,Rb,ASL#1	
	MOVCC	Rcnt,Rcnt,ASL#1	
	BCC	Div1	
	MOV	Rc,#0	
Div2	CMP	Ra,Rb	; Test for possible subtraction.
	SUBCS	Ra,Ra,Rb	; Subtract if ok,
	ADDCS	Rc,Rc,Rcnt	; Put relevant bit into result
	MOVS	Rcnt,Rcnt,LSR#1	; Shift control bit
	MOVNE	Rb,Rb,LSR#1	; Halve unless finished.
	BNE	Div2	; Divide result in Rc, remainder in Ra.

Overflow Eetection in the ARM7TDMI

1. Overflow in unsigned multiply with a 32-bit result

	UMULL	Rd,Rt,Rm,Rn	; 3 to 6 cycles
	TEQ	Rt,#0	; +1 cycle and a register
	BNE	overflow	

2. Overflow in signed multiply with a 32-bit result

	SMULL	Rd,Rt,Rm,Rn	; 3 to 6 cycles
	TEQ	Rt,Rd ASR#31	; +1 cycle and a register
	BNE	overflow	

3. Overflow in unsigned multiply accumulate with a 32 bit result

	UMLAL	Rd,Rt,Rm,Rn	; 4 to 7 cycles
	TEQ	Rt,#0	; +1 cycle and a register
	BNE	overflow	

4. Overflow in signed multiply accumulate with a 32 bit result

	SMLAL	Rd,Rt,Rm,Rn	; 4 to 7 cycles
	TEQ	Rt,Rd, ASR#31	; +1 cycle and a register
	BNE	overflow	

5. Overflow in unsigned multiply accumulate with a 64 bit result

UMULL	RI,Rh,Rm,Rn	; 3 to 6 cycles
ADDS	RI,RI,Ra1	; Lower accumulate
ADC	Rh,Rh,Ra2	; Upper accumulate
BCS	overflow	; 1 cycle and 2 registers

6. Overflow in signed multiply accumulate with a 64 bit result

SMULL	RI,Rh,Rm,Rn	; 3 to 6 cycles
ADDS	RI,RI,Ra1	; Lower accumulate
ADC	Rh,Rh,Ra2	; Upper accumulate
BVS	overflow	; 1 cycle and 2 registers

NOTE

Overflow checking is not applicable to unsigned and signed multiplies with a 64-bit result, since overflow does not occur in such calculations.

PSEUDO-RANDOM BINARY SEQUENCE GENERATOR

It is often necessary to generate (pseudo-) random numbers and the most efficient algorithms are based on shift generators with exclusive-OR feedback rather like a cyclic redundancy check generator. Unfortunately the sequence of a 32 bit generator needs more than one feedback tap to be maximal length (i.e. $2^{32}-1$ cycles before repetition), so this example uses a 33 bit register with taps at bits 33 and 20. The basic algorithm is newbit:=bit 33 eor bit 20, shift left the 33 bit number and put in newbit at the bottom; this operation is performed for all the newbits needed (i.e. 32 bits). The entire operation can be done in 5 S cycles:

		; Enter with seed in Ra (32 bits),
		; Rb (1 bit in Rb lsb), uses Rc.
TST	Rb,Rb,LSR#1	; Top bit into carry
MOVS	Rc,Ra,RRX	; 33 bit rotate right
ADC	Rb,Rb,Rb	; Carry into lsb of Rb
EOR	Rc,Rc,Ra,LSL#12	; (involved!)
EOR	Ra,Rc,Rc,LSR#20	; (similarly involved!) new seed in Ra, Rb as before

MULTIPLICATION BY CONSTANT USING THE BARREL SHIFTER

Multiplication by 2^n (1,2,4,8,16,32..)

```
MOV    Ra, Rb, LSL #n
```

Multiplication by 2^{n+1} (3,5,9,17..)

```
ADD    Ra,Ra,Ra,LSL #n
```

Multiplication by 2^{n-1} (3,7,15..)

```
RSB    Ra,Ra,Ra,LSL #n
```

Multiplication by 6

```

ADD    Ra,Ra,Ra,LSL #1    ; Multiply by 3
MOV    Ra,Ra,LSL#1       ; and then by 2

```

Multiply by 10 and add in extra number

```

ADD    Ra,Ra,Ra,LSL#2    ; Multiply by 5
ADD    Ra,Rc,Ra,LSL#1    ; Multiply by 2 and add in next digit

```

General recursive method for $Rb := Ra * C$, C a constant:

1. If C even, say $C = 2^n * D$, D odd:

```

D=1:    MOV    Rb,Ra,LSL #n
D<>1:   {Rb := Ra*D}
MOV     Rb,Rb,LSL #n

```

2. If $C \text{ MOD } 4 = 1$, say $C = 2^n * D + 1$, D odd, $n > 1$:

```

D=1:    ADD    Rb,Ra,Ra,LSL #n
D<>1:   {Rb := Ra*D}
ADD     Rb,Ra,Rb,LSL #n

```

3. If $C \text{ MOD } 4 = 3$, say $C = 2^n * D - 1$, D odd, $n > 1$:

```

D=1:    RSB   Rb,Ra,Ra,LSL #n
D<>1:   {Rb := Ra*D}
RSB     Rb,Ra,Rb,LSL #n

```

This is not quite optimal, but close. An example of its non-optimality is multiply by 45 which is done by:

```

RSB    Rb,Ra,Ra,LSL#2    ; Multiply by 3
RSB    Rb,Ra,Rb,LSL#2    ; Multiply by  $4*3-1 = 11$ 
ADD    Rb,Ra,Rb,LSL# 2   ; Multiply by  $4*11+1 = 45$ 

```

rather than by:

```

ADD    Rb,Ra,Ra,LSL#3    ; Multiply by 9
ADD    Rb,Rb,Rb,LSL#2    ; Multiply by  $5*9 = 45$ 

```

LOADING A WORD FROM AN UNKNOWN ALIGNMENT

BIC	Rb,Ra,#3	; Enter with address in Ra (32 bits) uses
LDMIA	Rb,{Rd,Rc}	; Rb, Rc result in Rd. Note d must be less than c e.g. 0,1
AND	Rb,Ra,#3	; Get word aligned address
MOVS	Rb,Rb,LSL#3	; Get 64 bits containing answer
MOVNE	Rd,Rd,LSR Rb	; Correction factor in bytes
RSBNE	Rb,Rb,#32	; ...now in bits and test if aligned
ORRNE	Rd,Rd,Rc,LSL Rb	; Produce bottom of result word (if not aligned)
		; Get other shift amount
		; Combine two halves to get result

NOTES

THUMB INSTRUCTION SET FORMAT

The thumb instruction sets are 16-bit versions of ARM instruction sets (32-bit format). The ARM instructions are reduced to 16-bit versions, Thumb instructions, at the cost of versatile functions of the ARM instruction sets. The thumb instructions are decompressed to the ARM instructions by the Thumb decompressor inside the ARM7TDMI core.

As the Thumb instructions are compressed ARM instructions, the Thumb instructions have the 16-bit format instructions and have some restrictions. The restrictions by 16-bit format is fully notified for using the Thumb instructions.

FORMAT SUMMARY

The THUMB instruction set formats are shown in the following figure.

	15	14	13	12	11	10	9	8	7	6	5	4	3	2	1	0	
1	0	0	0	Op		Offset5					Rs	Rd					Move Shifted register
2	0	0	0	1	1	I	Op	Rn/offset3			Rs	Rd					Add/subtract
3	0	0	1	Op		Rd					Offset8					Move/compare/add/ subtract immediate	
4	0	1	0	0	0	0	Op				Rs	Rd					ALU operations
5	0	1	0	0	0	1	Op	H1	H2	Rs/Hs			Rd/Hd				Hi register operations /branch exchange
6	0	1	0	0	1	Rd					Word8					PC-relative load	
7	0	1	0	1	L	B	0	Ro			Rb	Rd					Load/store with register offset
8	0	1	0	1	H	S	1	Ro			Rb	Rd					Load/store sign-extended byte/halfword
9	0	1	1	B	L	Offset5					Rb	Rd					Load/store with immediate offset
10	1	0	0	0	L	Offset5					Rb	Rd					Load/store halfword
11	1	0	0	1	L	Rd					Word8					SP-relative load/store	
12	1	0	1	0	SP	Rd					Word8					Load address	
13	1	0	1	1	0	0	0	0	S	SWord7							Add offset to stack pointer
14	1	0	1	1	L	1	0	R	Rlist								Push/pop register
15	1	1	0	0	L	Rb					Rlist					Multiple load/store	
16	1	1	0	1	Cond					Softset8					Conditional branch		
17	1	1	0	1	1	1	1	1	Value8							Software interrupt	
18	1	1	1	0	0	Offset11										Unconditional branch	
19	1	1	1	1	H	Offset										Long branch with link	

Figure 3-29. THUMB Instruction Set Formats

OPCODE SUMMARY

The following table summarizes the THUMB instruction set. For further information about a particular instruction please refer to the sections listed in the right-most column.

Table 3-7. THUMB Instruction Set Opcodes

Mnemonic	Instruction	Lo-Register Operand	Hi-Register Operand	Condition Codes Set
ADC	Add with Carry	Y	–	Y
ADD	Add	Y	–	Y (1)
AND	AND	Y	–	Y
ASR	Arithmetic Shift Right	Y	–	Y
B	Unconditional branch	Y	–	–
Bxx	Conditional branch	Y	–	–
BIC	Bit Clear	Y	–	Y
BL	Branch and Link	–	–	–
BX	Branch and Exchange	Y	Y	–
CMN	Compare Negative	Y	–	Y
CMP	Compare	Y	Y	Y
EOR	EOR	Y	–	Y
LDMIA	Load multiple	Y	–	–
LDR	Load word	Y	–	–
LDRB	Load byte	Y	–	–
LDRH	Load half-word	Y	–	–
LSL	Logical Shift Left	Y	–	Y
LDSB	Load sign-extended byte	Y	–	–
LDSH	Load sign-extended half-word	Y	–	–
LSR	Logical Shift Right	Y	–	Y
MOV	Move register	Y	Y	Y (2)
MUL	Multiply	Y	–	Y
MVN	Move Negative register	Y	–	Y

Table 3-7. THUMB Instruction Set Opcodes (Continued)

Mnemonic	Instruction	Lo-Register Operand	Hi-Register Operand	Condition Codes Set
NEG	Negate	Y	–	Y
ORR	OR	Y	–	Y
POP	Pop register	Y	–	–
PUSH	Push register	Y	–	–
ROR	Rotate Right	Y	–	Y
SBC	Subtract with Carry	Y	–	Y
STMIA	Store Multiple	Y	–	–
STR	Store word	Y	–	–
STRB	Store byte	Y	–	–
STRH	Store half-word	Y	–	–
SWI	Software Interrupt	–	–	–
SUB	Subtract	Y	–	Y
TST	Test bits	Y	–	Y

NOTES:

1. The condition codes are unaffected by the format 5, 12 and 13 versions of this instruction.
2. The condition codes are unaffected by the format 5 version of this instruction.

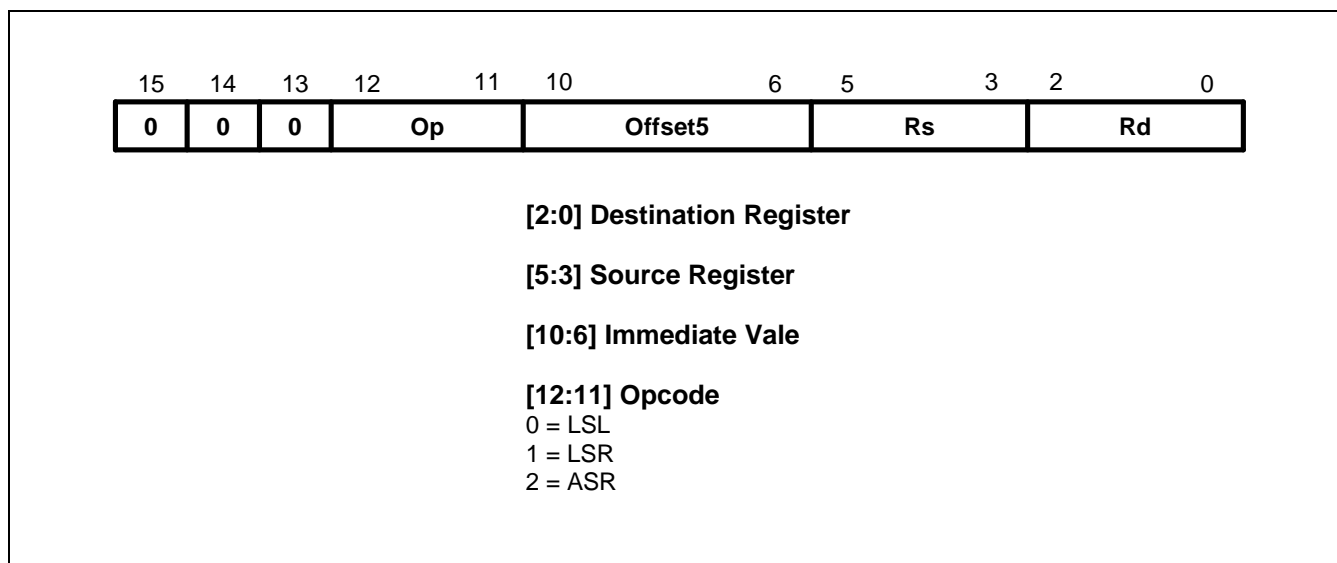
FORMAT 1: MOVE SHIFTED REGISTER**Figure 3-30. Format 1****OPERATION**

These instructions move a shifted value between Lo registers. The THUMB assembler syntax is shown in Table 3-8.

NOTE

All instructions in this group set the CPSR condition codes.

Table 3-8. Summary of Format 1 Instructions

OP	THUMB Assembler	ARM Equipment	Action
00	LSL Rd, Rs, #Offset5	MOVS Rd, Rs, LSL #Offset5	Shift Rs left by a 5-bit immediate value and store the result in Rd.
01	LSR Rd, Rs, #Offset5	MOVS Rd, Rs, LSR #Offset5	Perform logical shift right on Rs by a 5-bit immediate value and store the result in Rd.
10	ASR Rd, Rs, #Offset5	MOVS Rd, Rs, ASR #Offset5	Perform arithmetic shift right on Rs by a 5-bit immediate value and store the result in Rd.

INSTRUCTION CYCLE TIMES

All instructions in this format have an equivalent ARM instruction as shown in Table 3-8. The instruction cycle times for the THUMB instruction are identical to that of the equivalent ARM instruction.

EXAMPLES

LSR R2, R5, #27 ; Logical shift right the contents
 ; of R5 by 27 and store the result in R2.
 ; Set condition codes on the result.

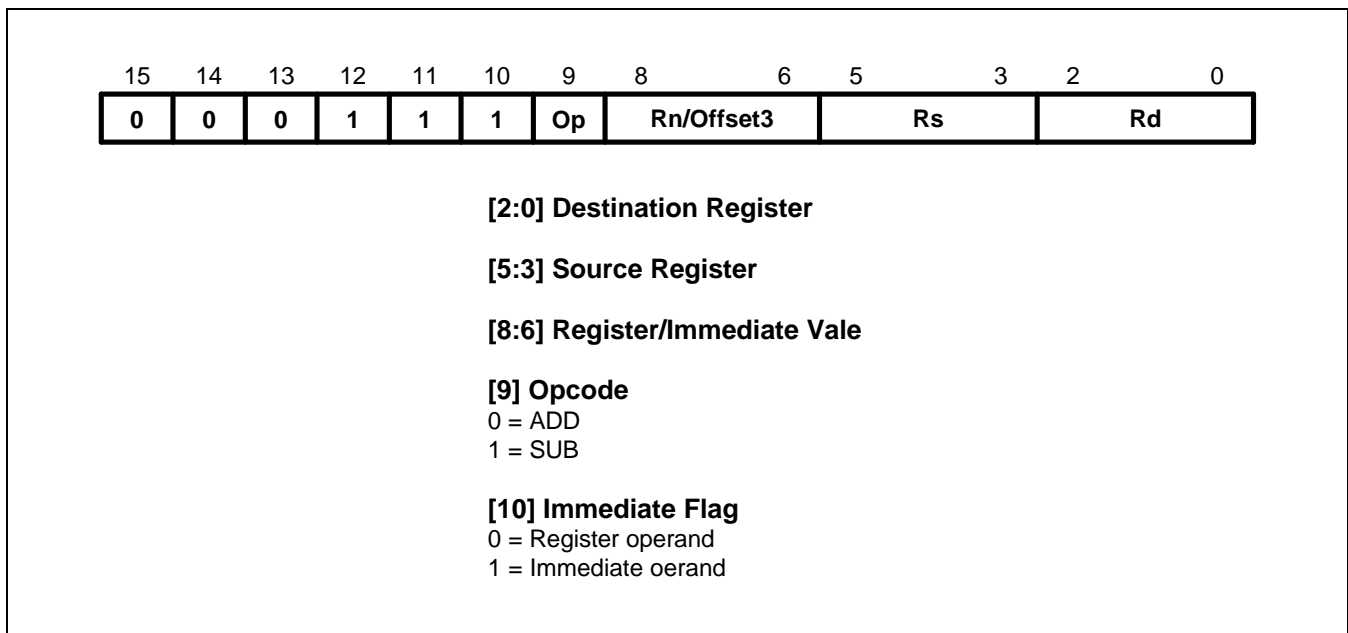
FORMAT 2: ADD/SUBTRACT**Figure 3-31. Format 2****OPERATION**

These instructions allow the contents of a Lo register or a 3-bit immediate value to be added to or subtracted from a Lo register. The THUMB assembler syntax is shown in Table 3-9.

NOTE

All instructions in this group set the CPSR condition codes.

Table 3-9. Summary of Format 2 Instructions

OP	I	THUMB Assembler	ARM Equipment	Action
0	0	ADD Rd, Rs, Rn	ADDS Rd, Rs, Rn	Add contents of Rn to contents of Rs. Place result in Rd.
0	1	ADD Rd, Rs, #Offset3	ADDS Rd, Rs, #Offset3	Add 3-bit immediate value to contents of Rs. Place result in Rd.
1	0	SUB Rd, Rs, Rn	SUBS Rd, Rs, Rn	Subtract contents of Rn from contents of Rs. Place result in Rd.
1	1	SUB Rd, Rs, #Offset3	SUBS Rd, Rs, #Offset3	Subtract 3-bit immediate value from contents of Rs. Place result in Rd.

INSTRUCTION CYCLE TIMES

All instructions in this format have an equivalent ARM instruction as shown in Table 3-9. The instruction cycle times for the THUMB instruction are identical to that of the equivalent ARM instruction.

EXAMPLES

ADD	R0, R3, R4	; R0 := R3 + R4 and set condition codes on the result.
SUB	R6, R2, #6	; R6 := R2 - 6 and set condition codes.

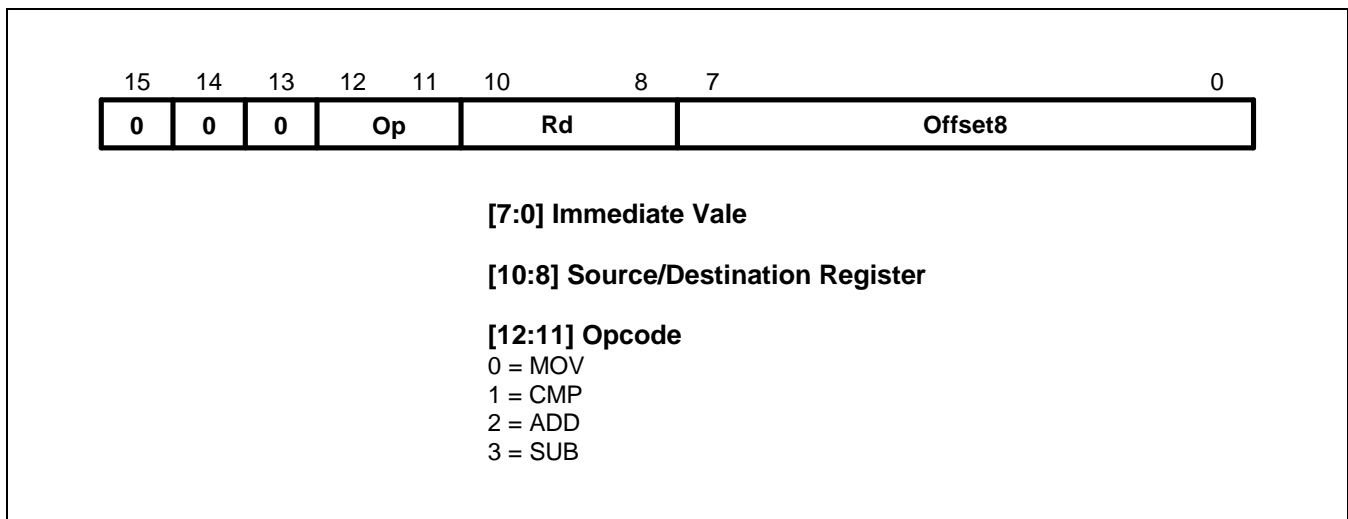
FORMAT 3: MOVE/COMPARE/ADD/SUBTRACT IMMEDIATE**Figure 3-32. Format 3****OPERATIONS**

The instructions in this group perform operations between a Lo register and an 8-bit immediate value. The THUMB assembler syntax is shown in Table 3-10.

NOTE

All instructions in this group set the CPSR condition codes.

Table 3-10. Summary of Format 3 Instructions

OP	THUMB Assembler	ARM Equipment	Action
00	MOV Rd, #Offset8	MOVS Rd, #Offset8	Move 8-bit immediate value into Rd.
01	CMP Rd, #Offset8	CMP Rd, #Offset8	Compare contents of Rd with 8-bit immediate value.
10	ADD Rd, #Offset8	ADDS Rd, Rd, #Offset8	Add 8-bit immediate value to contents of Rd and place the result in Rd.
11	SUB Rd, #Offset8	SUBS Rd, Rd, #Offset8	Subtract 8-bit immediate value from contents of Rd and place the result in Rd.

INSTRUCTION CYCLE TIMES

All instructions in this format have an equivalent ARM instruction as shown in Table 3-10. The instruction cycle times for the THUMB instruction are identical to that of the equivalent ARM instruction.

EXAMPLES

MOV	R0, #128	; R0 := 128 and set condition codes
CMP	R2, #62	; Set condition codes on R2 - 62
ADD	R1, #255	; R1 := R1 + 255 and set condition codes
SUB	R6, #145	; R6 := R6 - 145 and set condition codes

FORMAT 4: ALU OPERATIONS

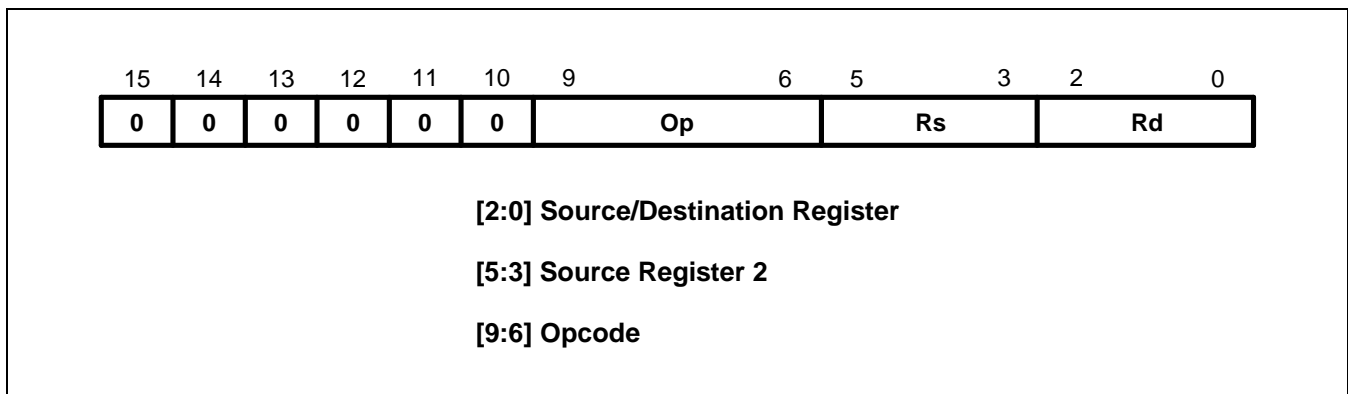

Figure 3-33. Format 4

OPERATION

The following instructions perform ALU operations on a Lo register pair.

NOTE

All instructions in this group set the CPSR condition codes.

Table 3-11. Summary of Format 4 Instructions

OP	THUMB Assembler	ARM Equipment	Action
0000	AND Rd, Rs	ANDS Rd, Rd, Rs	Rd := Rd AND Rs
0001	EOR Rd, Rs	EORS Rd, Rd, Rs	Rd := Rd EOR Rs
0010	LSL Rd, Rs	MOVS Rd, Rd, LSL Rs	Rd := Rd << Rs
0011	LSR Rd, Rs	MOVS Rd, Rd, LSR Rs	Rd := Rd >> Rs
0100	ASR Rd, Rs	MOVS Rd, Rd, ASR Rs	Rd := Rd ASR Rs
0101	ADC Rd, Rs	ADCS Rd, Rd, Rs	Rd := Rd + Rs + C-bit
0110	SBC Rd, Rs	SBCS Rd, Rd, Rs	Rd := Rd - Rs - NOT C-bit
0111	ROR Rd, Rs	MOVS Rd, Rd, ROR Rs	Rd := Rd ROR Rs
1000	TST Rd, Rs	TST Rd, Rs	Set condition codes on Rd AND Rs
1001	NEG Rd, Rs	RSBS Rd, Rs, #0	Rd = - Rs
1010	CMP Rd, Rs	CMP Rd, Rs	Set condition codes on Rd - Rs
1011	CMN Rd, Rs	CMN Rd, Rs	Set condition codes on Rd + Rs
1100	ORR Rd, Rs	ORRS Rd, Rd, Rs	Rd := Rd OR Rs
1101	MUL Rd, Rs	MULS Rd, Rs, Rd	Rd := Rs * Rd
1110	BIC Rd, Rs	BICS Rd, Rd, Rs	Rd := Rd AND NOT Rs
1111	MVN Rd, Rs	MVNS Rd, Rs	Rd := NOT Rs

INSTRUCTION CYCLE TIMES

All instructions in this format have an equivalent ARM instruction as shown in Table 3-11. The instruction cycle times for the THUMB instruction are identical to that of the equivalent ARM instruction.

EXAMPLES

EOR	R3, R4	; R3 := R3 EOR R4 and set condition codes
ROR	R1, R0	; Rotate Right R1 by the value in R0, store ; the result in R1 and set condition codes
NEG	R5, R3	; Subtract the contents of R3 from zero, ; Store the result in R5. Set condition codes ie R5 = - R3
CMP	R2, R6	; Set the condition codes on the result of R2 - R6
MUL	R0, R7	; R0 := R7 * R0 and set condition codes

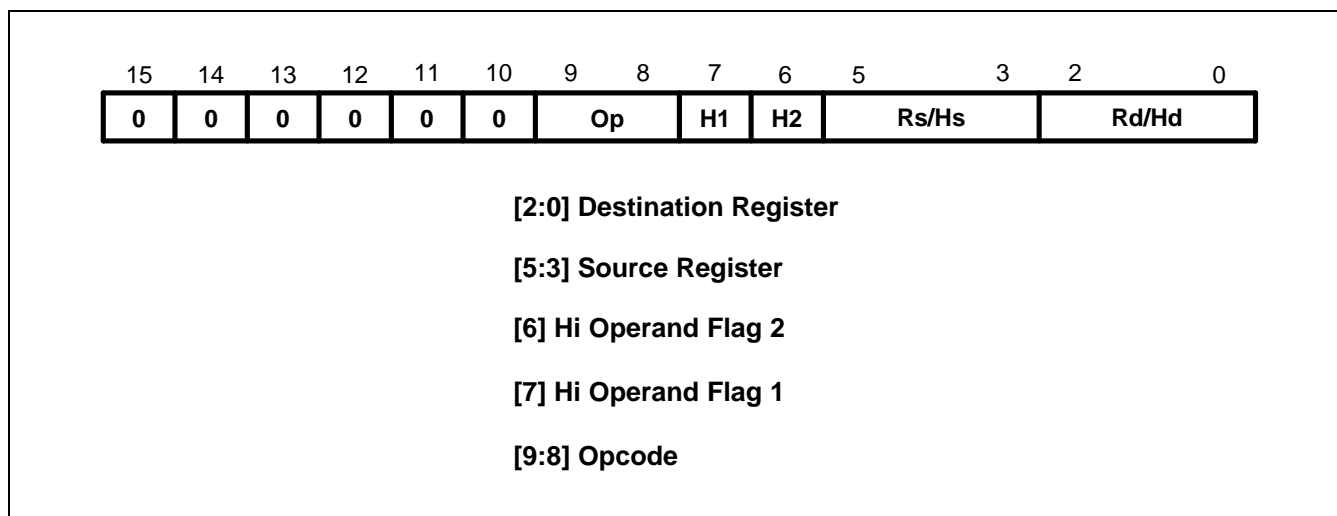
FORMAT 5: HI-REGISTER OPERATIONS/BRANCH EXCHANGE**Figure 3-34. Format 5****OPERATION**

There are four sets of instructions in this group. The first three allow ADD, CMP and MOV operations to be performed between Lo and Hi registers, or a pair of Hi registers. The fourth, BX, allows a Branch to be performed which may also be used to switch processor state. The THUMB assembler syntax is shown in Table 3-12.

NOTE

In this group only CMP (Op = 01) sets the CPSR condition codes.

The action of H1= 0, H2 = 0 for Op = 00 (ADD), Op =01 (CMP) and Op = 10 (MOV) is undefined, and should not be used.

Table 3-12. Summary of Format 5 Instructions

Op	H1	H2	THUMB assembler	ARM equivalent	Action
00	0	1	ADD Rd, Hs	ADD Rd, Rd, Hs	Add a register in the range 8-15 to a register in the range 0-7.
00	1	0	ADD Hd, Rs	ADD Hd, Hd, Rs	Add a register in the range 0-7 to a register in the range 8-15.
00	1	1	ADD Hd, Hs	ADD Hd, Hd, Hs	Add two registers in the range 8-15
01	0	1	CMP Rd, Hs	CMP Rd, Hs	Compare a register in the range 0-7 with a register in the range 8-15. Set the condition code flags on the result.
01	1	0	CMP Hd, Rs	CMP Hd, Rs	Compare a register in the range 8-15 with a register in the range 0-7. Set the condition code flags on the result.

Table 3-12. Summary of Format 5 Instructions (Continued)

Op	H1	H2	THUMB assembler	ARM equivalent	Action
01	1	1	CMP Hd, Hs	CMP Hd, Hs	Compare two registers in the range 8-15. Set the condition code flags on the result.
10	0	1	MOV Rd, Hs	MOV Rd, Hs	Move a value from a register in the range 8-15 to a register in the range 0-7.
10	1	0	MOV Hd, Rs	MOV Hd, Rs	Move a value from a register in the range 0-7 to a register in the range 8-15.
10	1	1	MOV Hd, Hs	MOV Hd, Hs	Move a value between two registers in the range 8-15.
11	0	0	BX Rs	BX Rs	Perform branch (plus optional state change) to address in a register in the range 0-7.
11	0	1	BX Hs	BX Hs	Perform branch (plus optional state change) to address in a register in the range 8-15.

INSTRUCTION CYCLE TIMES

All instructions in this format have an equivalent ARM instruction as shown in Table 3-12. The instruction cycle times for the THUMB instruction are identical to that of the equivalent ARM instruction.

THE BX INSTRUCTION

BX performs a Branch to a routine whose start address is specified in a Lo or Hi register.

Bit 0 of the address determines the processor state on entry to the routine:

- Bit 0 = 0 Causes the processor to enter ARM state.
- Bit 0 = 1 Causes the processor to enter THUMB state.

NOTE

The action of H1 = 1 for this instruction is undefined, and should not be used.

EXAMPLES

Hi-Register Operations

```

ADD    PC, R5           ; PC := PC + R5 but don't set the condition codes.
CMP    R4, R12          ; Set the condition codes on the result of R4 - R12.
MOV    R15, R14         ; Move R14 (LR) into R15 (PC)
                          ; but don't set the condition codes,
                          ; eg. return from subroutine.

```

Branch and Exchange

```

ADR    R1,outofTHUMB    ; Switch from THUMB to ARM state.
MOV    R11,R1           ; Load address of outofTHUMB into R1.
BX     R11              ; Transfer the contents of R11 into the PC.
                          ; Bit 0 of R11 determines whether
                          ; ARM or THUMB state is entered, ie. ARM state here.
•
•
ALIGN
CODE32
outofTHUMB              ; Now processing ARM instructions...

```

USING R15 AS AN OPERAND

If R15 is used as an operand, the value will be the address of the instruction + 4 with bit 0 cleared. Executing a BX PC in THUMB state from a non-word aligned address will result in unpredictable execution.

FORMAT 6: PC-RELATIVE LOAD

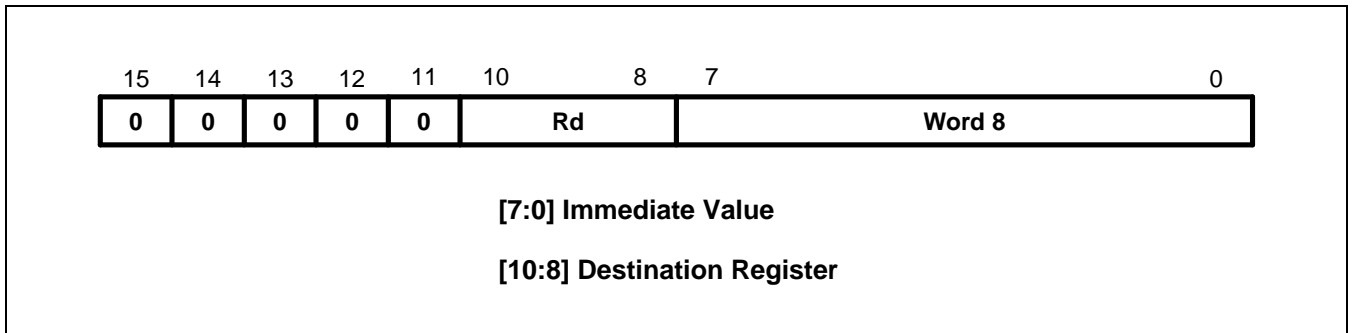

Figure 3-35. Format 6

OPERATION

This instruction loads a word from an address specified as a 10-bit immediate offset from the PC. The THUMB assembler syntax is shown below.

Table 3-13. Summary of PC-Relative Load Instruction

THUMB assembler	ARM equivalent	Action
LDR Rd, [PC, #Imm]	LDR Rd, [R15, #Imm]	Add unsigned offset (255 words, 1020 bytes) in Imm to the current value of the PC. Load the word from the resulting address into Rd.

NOTE: The value specified by #Imm is a full 10-bit address, but must always be word-aligned (ie with bits 1:0 set to 0), since the assembler places #Imm >> 2 in field Word 8. The value of the PC will be 4 bytes greater than the address of this instruction, but bit 1 of the PC is forced to 0 to ensure it is word aligned.

INSTRUCTION CYCLE TIMES

All instructions in this format have an equivalent ARM instruction. The instruction cycle times for the THUMB instruction are identical to that of the equivalent ARM instruction.

EXAMPLES

```
LDR R3,[PC,#844]           ; Load into R3 the word found at the
                           ; address formed by adding 844 to PC.
                           ; bit[1] of PC is forced to zero.
                           ; Note that the THUMB opcode will contain
                           ; 211 as the Word8 value.
```

FORMAT 7: LOAD/STORE WITH REGISTER OFFSET

Figure 3-36. Format 7

OPERATION

These instructions transfer byte or word values between registers and memory. Memory addresses are pre-indexed using an offset register in the range 0-7. The THUMB assembler syntax is shown in Table 3-14.

Table 3-14. Summary of Format 7 Instructions

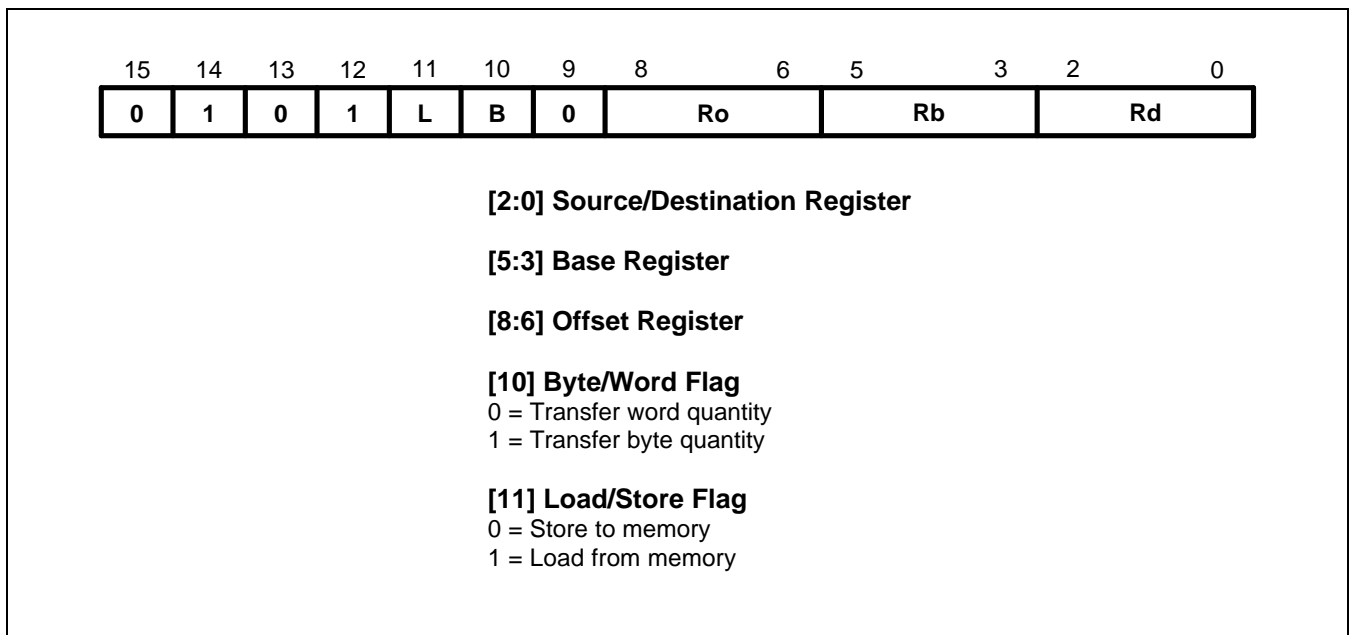
L	B	THUMB assembler	ARM equivalent	Action
0	0	STR Rd, [Rb, Ro]	STR Rd, [Rb, Ro]	Pre-indexed word store: Calculate the target address by adding together the value in Rb and the value in Ro. Store the contents of Rd at the address.
0	1	STRB Rd, [Rb, Ro]	STRB Rd, [Rb, Ro]	Pre-indexed byte store: Calculate the target address by adding together the value in Rb and the value in Ro. Store the byte value in Rd at the resulting address.
1	0	LDR Rd, [Rb, Ro]	LDR Rd, [Rb, Ro]	Pre-indexed word load: Calculate the source address by adding together the value in Rb and the value in Ro. Load the contents of the address into Rd.
1	1	LDRB Rd, [Rb, Ro]	LDRB Rd, [Rb, Ro]	Pre-indexed byte load: Calculate the source address by adding together the value in Rb and the value in Ro. Load the byte value at the resulting address.

INSTRUCTION CYCLE TIMES

All instructions in this format have an equivalent ARM instruction as shown in Table 3-14. The instruction cycle times for the THUMB instruction are identical to that of the equivalent ARM instruction.

EXAMPLES

```

STR      R3, [R2,R6]      ; Store word in R3 at the address
                          ; formed by adding R6 to R2.
LDRB    R2, [R0,R7]      ; Load into R2 the byte found at
                          ; the address formed by adding R7 to R0.

```

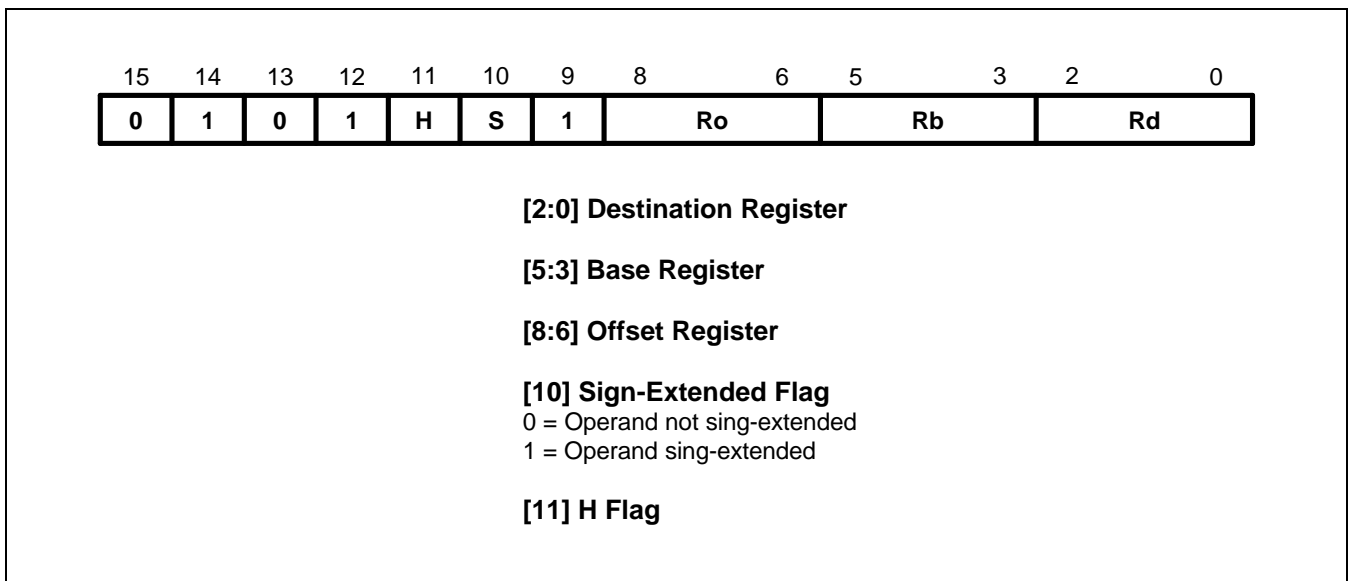
FORMAT 8: LOAD/STORE SIGN-EXTENDED BYTE/HALF-WORD**Figure 3-37. Format 8****OPERATION**

These instructions load optionally sign-extended bytes or half-words, and store half-words. The THUMB assembler syntax is shown below.

Table 3-15. Summary of format 8 instructions

L	B	THUMB assembler	ARM equivalent	Action
0	0	STRH Rd, [Rb, Ro]	STRH Rd, [Rb, Ro]	Store half-word: Add Ro to base address in Rb. Store bits 0-15 of Rd at the resulting address.
0	1	LDRH Rd, [Rb, Ro]	LDRH Rd, [Rb, Ro]	Load half-word: Add Ro to base address in Rb. Load bits 0-15 of Rd from the resulting address, and set bits 16-31 of Rd to 0.
1	0	LDSB Rd, [Rb, Ro]	LDRSB Rd, [Rb, Ro]	Load sign-extended byte: Add Ro to base address in Rb. Load bits 0-7 of Rd from the resulting address, and set bits 8-31 of Rd to bit 7.
1	1	LDSH Rd, [Rb, Ro]	LDRSH Rd, [Rb, Ro]	Load sign-extended half-word: Add Ro to base address in Rb. Load bits 0-15 of Rd from the resulting address, and set bits 16-31 of Rd to bit 15.

INSTRUCTION CYCLE TIMES

All instructions in this format have an equivalent ARM instruction as shown in Table 3-15. The instruction cycle times for the THUMB instruction are identical to that of the equivalent ARM instruction.

EXAMPLES

STRH	R4, [R3, R0]	; Store the lower 16 bits of R4 at the
		; address formed by adding R0 to R3.
LDSB	R2, [R7, R1]	; Load into R2 the sign extended byte
		; found at the address formed by adding R1 to R7.
LDSH	R3, [R4, R2]	; Load into R3 the sign extended half-word
		; found at the address formed by adding R2 to R4.

FORMAT 9: LOAD/STORE WITH IMMEDIATE OFFSET

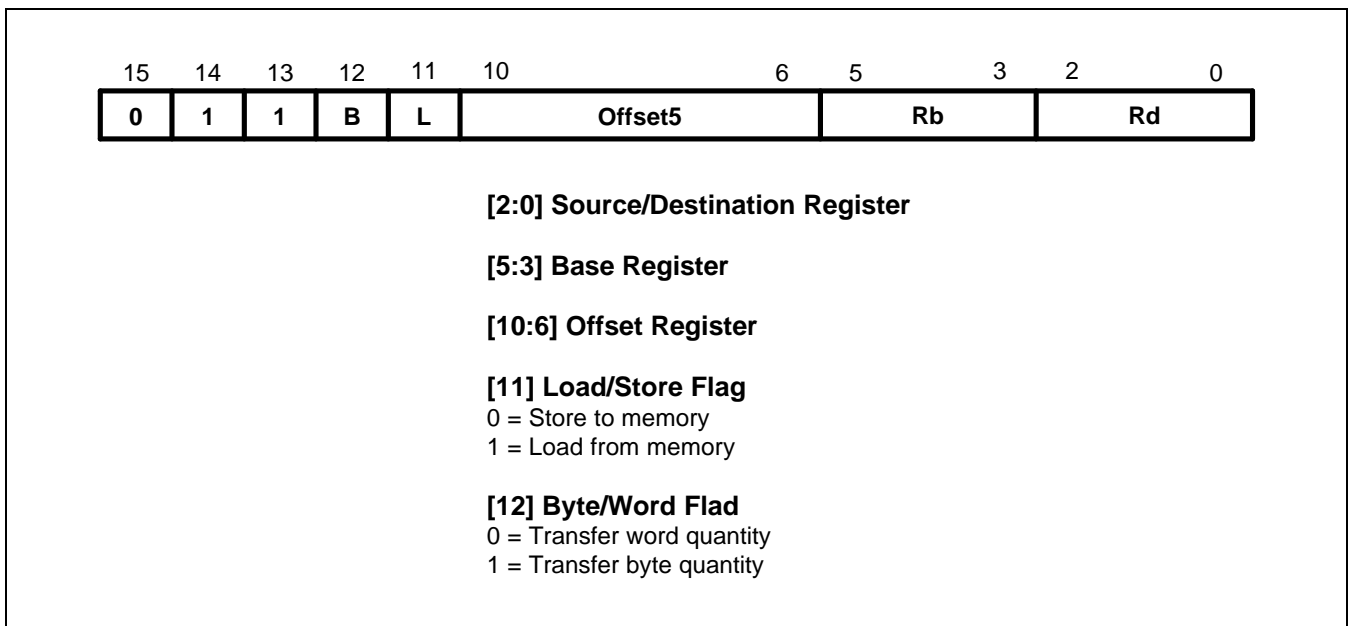

Figure 3-38. Format 9

OPERATION

These instructions transfer byte or word values between registers and memory using an immediate 5 or 7-bit offset. The THUMB assembler syntax is shown in Table 3-16.

Table 3-16. Summary of Format 9 Instructions

L	B	THUMB assembler	ARM equivalent	Action
0	0	STR Rd, [Rb, #Imm]	STR Rd, [Rb, #Imm]	Calculate the target address by adding together the value in Rb and Imm. Store the contents of Rd at the address.
1	0	LDR Rd, [Rb, #Imm]	LDR Rd, [Rb, #Imm]	Calculate the source address by adding together the value in Rb and Imm. Load Rd from the address.
0	1	STRB Rd, [Rb, #Imm]	STRB Rd, [Rb, #Imm]	Calculate the target address by adding together the value in Rb and Imm. Store the byte value in Rd at the address.
1	1	LDRB Rd, [Rb, #Imm]	LDRB Rd, [Rb, #Imm]	Calculate source address by adding together the value in Rb and Imm. Load the byte value at the address into Rd.

NOTE: For word accesses (B = 0), the value specified by #Imm is a full 7-bit address, but must be word-aligned (ie with bits 1:0 set to 0), since the assembler places #Imm >> 2 in the Offset5 field.

INSTRUCTION CYCLE TIMES

All instructions in this format have an equivalent ARM instruction as shown in Table 3-16. The instruction cycle times for the THUMB instruction are identical to that of the equivalent ARM instruction.

EXAMPLES

LDR	R2, [R5,#116]	; Load into R2 the word found at the ; address formed by adding 116 to R5. ; Note that the THUMB opcode will ; contain 29 as the Offset5 value.
STRB	R1, [R0,#13]	; Store the lower 8 bits of R1 at the ; address formed by adding 13 to R0. ; Note that the THUMB opcode will ; contain 13 as the Offset5 value.

FORMAT 10: LOAD/STORE HALF-WORD

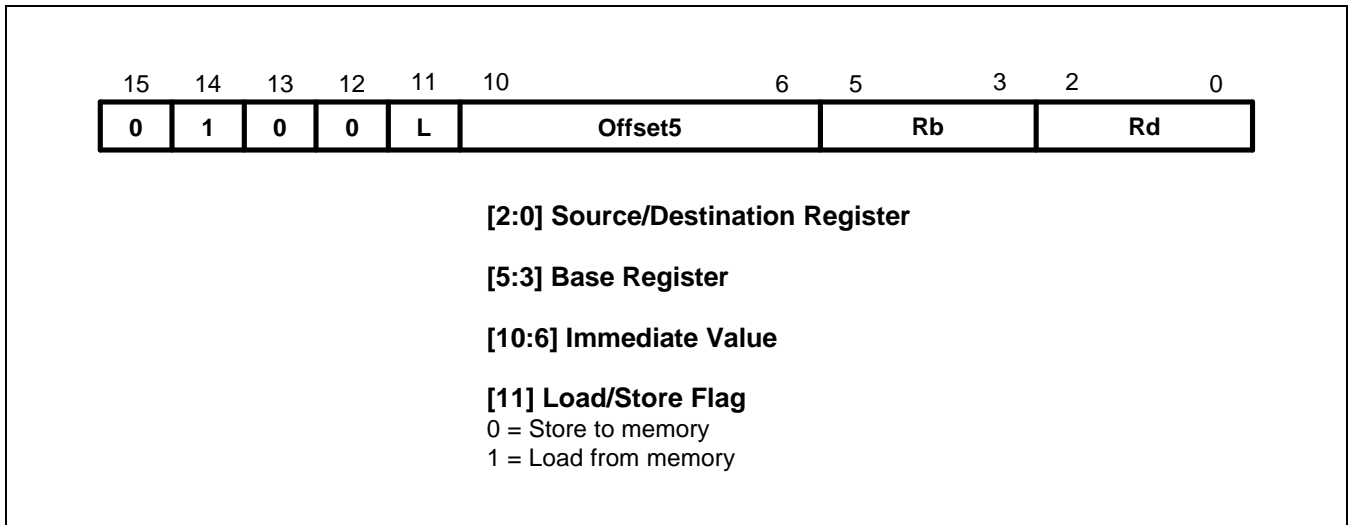

Figure 3-39. Format 10

OPERATION

These instructions transfer half-word values between a Lo register and memory. Addresses are pre-indexed, using a 6-bit immediate value. The THUMB assembler syntax is shown in Table 3-17.

Table 3-17. Half-word Data Transfer Instructions

L	THUMB assembler	ARM equivalent	Action
0	STRH Rd, [Rb, #Imm]	STRH Rd, [Rb, #Imm]	Add #Imm to base address in Rb and store bits 0 - 15 of Rd at the resulting address.
1	LDRH Rd, [Rb, #Imm]	LDRH Rd, [Rb, #Imm]	Add #Imm to base address in Rb. Load bits 0-15 from the resulting address into Rd and set bits 16-31 to zero.

NOTE: #Imm is a full 6-bit address but must be half-word-aligned (ie with bit 0 set to 0) since the assembler places #Imm >> 1 in the Offset5 field.

INSTRUCTION CYCLE TIMES

All instructions in this format have an equivalent ARM instruction as shown in Table 3-17. The instruction cycle times for the THUMB instruction are identical to that of the equivalent ARM instruction.

EXAMPLES

STRH	R6, [R1, #56]	; Store the lower 16 bits of R4 at the address formed by ; adding 56 R1. Note that the THUMB opcode will contain ; 28 as the Offset5 value.
LDRH	R4, [R7, #4]	; Load into R4 the half-word found at the address formed by ; adding 4 to R7. Note that the THUMB opcode will contain ; 2 as the Offset5 value.

FORMAT 12: LOAD ADDRESS

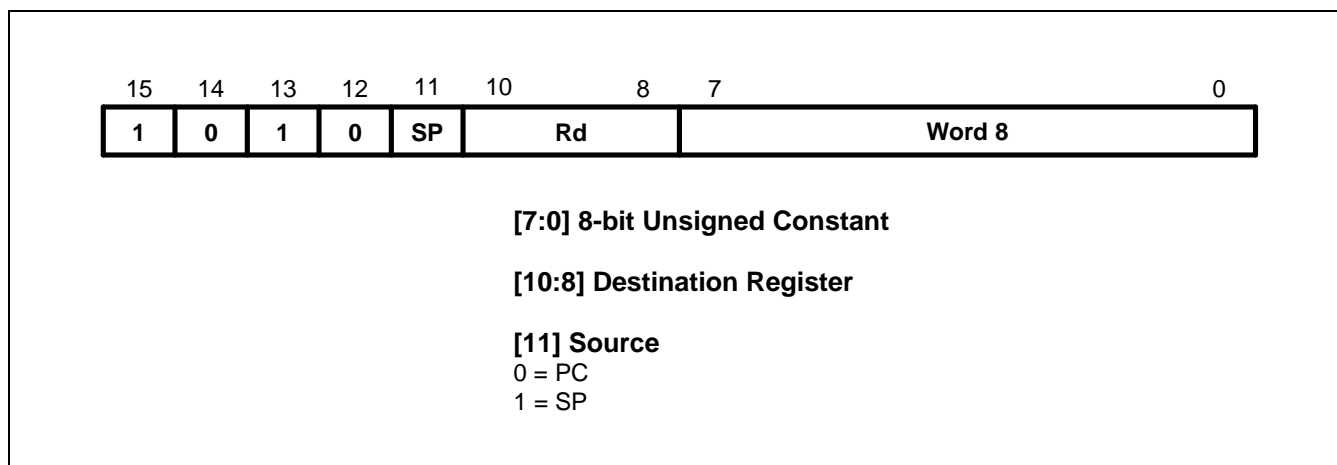

Figure 3-41. Format 12

OPERATION

These instructions calculate an address by adding an 10-bit constant to either the PC or the SP, and load the resulting address into a register. The THUMB assembler syntax is shown in the following table.

Table 3-19. Load Address

L	THUMB assembler	ARM equivalent	Action
0	ADD Rd, PC, #Imm	ADD Rd, R15, #Imm	Add #Imm to the current value of the program counter (PC) and load the result into Rd.
1	ADD Rd, SP, #Imm	ADD Rd, R13, #Imm	Add #Imm to the current value of the stack pointer (SP) and load the result into Rd.

NOTE: The value specified by #Imm is a full 10-bit value, but this must be word-aligned (ie with bits 1:0 set to 0) since the assembler places #Imm >> 2 in field Word 8.

Where the PC is used as the source register (SP = 0), bit 1 of the PC is always read as 0. The value of the PC will be 4 bytes greater than the address of the instruction before bit 1 is forced to 0.

The CPSR condition codes are unaffected by these instructions.

INSTRUCTION CYCLE TIMES

All instructions in this format have an equivalent ARM instruction as shown in Table 3-19. The instruction cycle times for the THUMB instruction are identical to that of the equivalent ARM instruction.

EXAMPLES

ADD	R2, PC, #572	; R2 := PC + 572, but don't set the ; condition codes. bit[1] of PC is forced to zero. ; Note that the THUMB opcode will ; contain 143 as the Word8 value.
ADD	R6, SP, #212	; R6 := SP (R13) + 212, but don't ; set the condition codes. ; Note that the THUMB opcode will ; contain 53 as the Word 8 value.

FORMAT 14: PUSH/POP REGISTERS

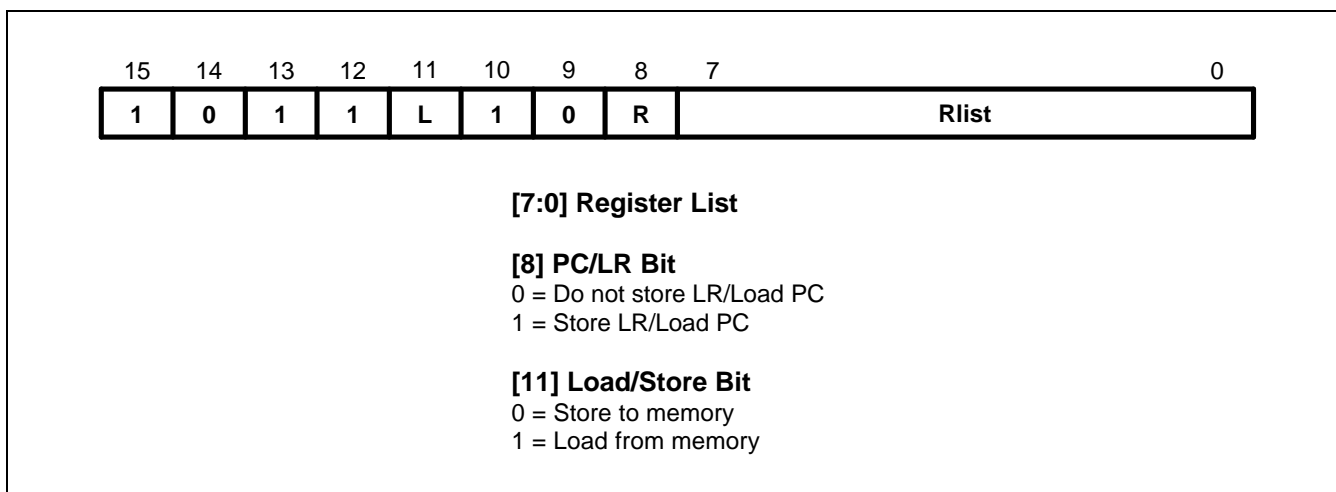

Figure 3-43. Format 14

OPERATION

The instructions in this group allow registers 0-7 and optionally LR to be pushed onto the stack, and registers 0-7 and optionally PC to be popped off the stack. The THUMB assembler syntax is shown in Table 3-21.

NOTE

The stack is always assumed to be Full Descending.

Table 3-21. PUSH and POP Instructions

L	B	THUMB assembler	ARM equivalent	Action
0	0	PUSH { Rlist }	STMDB R13!, { Rlist }	Push the registers specified by Rlist onto the stack. Update the stack pointer.
0	1	PUSH { Rlist, LR }	STMDB R13!, { Rlist, R14 }	Push the Link Register and the registers specified by Rlist (if any) onto the stack. Update the stack pointer.
1	0	POP { Rlist }	LDMIA R13!, { Rlist }	Pop values off the stack into the registers specified by Rlist. Update the stack pointer.
1	1	POP { Rlist, PC }	LDMIA R13!, {Rlist, R15}	Pop values off the stack and load into the registers specified by Rlist. Pop the PC off the stack. Update the stack pointer.

INSTRUCTION CYCLE TIMES

All instructions in this format have an equivalent ARM instruction as shown in Table 3-21. The instruction cycle times for the THUMB instruction are identical to that of the equivalent ARM instruction.

EXAMPLES

PUSH	{R0-R4,LR}	; Store R0,R1,R2,R3,R4 and R14 (LR) at ; the stack pointed to by R13 (SP) and update R13. ; Useful at start of a sub-routine to ; save workspace and return address.
POP	{R2,R6,PC}	; Load R2,R6 and R15 (PC) from the stack ; pointed to by R13 (SP) and update R13. ; Useful to restore workspace and return from sub-routine.

FORMAT 15: MULTIPLE LOAD/STORE

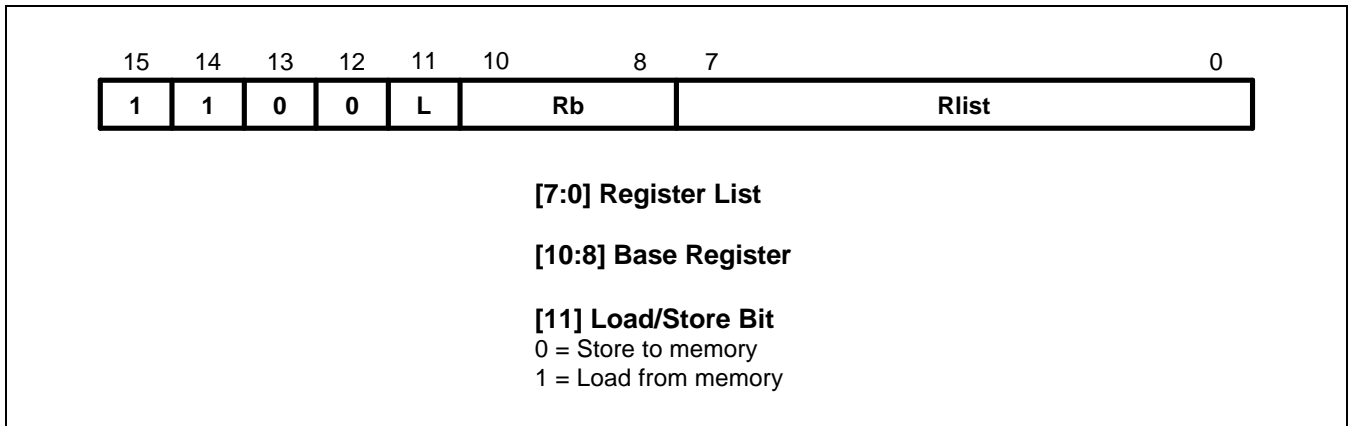

Figure 3-44. Format 15

OPERATION

These instructions allow multiple loading and storing of Lo registers. The THUMB assembler syntax is shown in the following table.

Table 3-22. The Multiple Load/Store Instructions

L	THUMB assembler	ARM equivalent	Action
0	STMIA Rb!, { Rlist }	STMIA Rb!, { Rlist }	Store the registers specified by Rlist, starting at the base address in Rb. Write back the new base address.
1	LDMIA Rb!, { Rlist }	LDMIA Rb!, { Rlist }	Load the registers specified by Rlist, starting at the base address in Rb. Write back the new base address.

INSTRUCTION CYCLE TIMES

All instructions in this format have an equivalent ARM instruction as shown in Table 3-22. The instruction cycle times for the THUMB instruction are identical to that of the equivalent ARM instruction.

EXAMPLES

```

STMIA    R0!, {R3-R7}           ; Store the contents of registers R3-R7
                                     ; starting at the address specified in
                                     ; R0, incrementing the addresses for each word.
                                     ; Write back the updated value of R0.
    
```

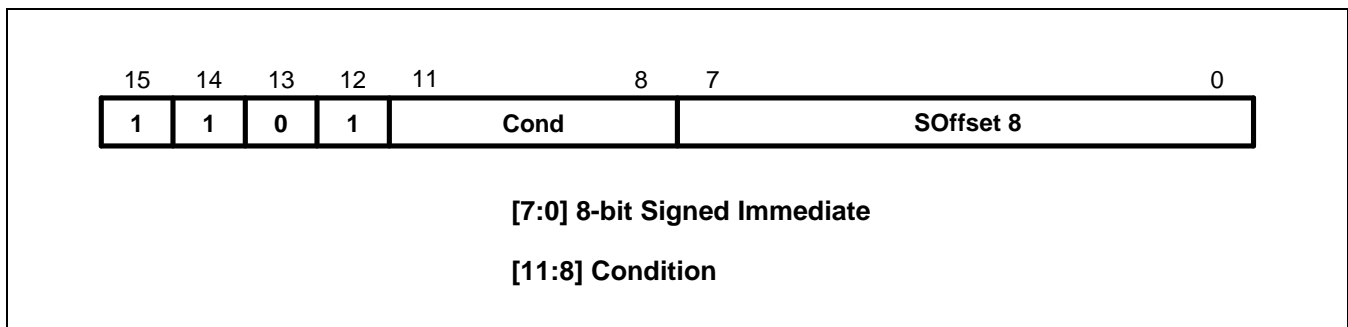
FORMAT 16: CONDITIONAL BRANCH**Figure 3-45. Format 16****OPERATION**

The instructions in this group all perform a conditional Branch depending on the state of the CPSR condition codes. The branch offset must take account of the prefetch operation, which causes the PC to be 1 word (4 bytes) ahead of the current instruction.

The THUMB assembler syntax is shown in the following table.

Table 3-23. The Conditional Branch Instructions

L	THUMB assembler	ARM equivalent	Action
0000	BEQ label	BEQ label	Branch if Z set (equal)
0001	BNE label	BNE label	Branch if Z clear (not equal)
0010	BCS label	BCS label	Branch if C set (unsigned higher or same)
0011	BCC label	BCC label	Branch if C clear (unsigned lower)
0100	BMI label	BMI label	Branch if N set (negative)
0101	BPL label	BPL label	Branch if N clear (positive or zero)
0110	BVS label	BVS label	Branch if V set (overflow)
0111	BVC label	BVC label	Branch if V clear (no overflow)
1000	BHI label	BHI label	Branch if C set and Z clear (unsigned higher)
1001	BLS label	BLS label	Branch if C clear or Z set (unsigned lower or same)

Table 3-23. The Conditional Branch Instructions (Continued)

L	THUMB assembler	ARM equivalent	Action
1001	BLS label	BLS label	Branch if C clear or Z set (unsigned lower or same)
1010	BGE label	BGE label	Branch if N set and V set, or N clear and V clear (greater or equal)
1011	BLT label	BLT label	Branch if N set and V clear, or N clear and V set (less than)
1100	BGT label	BGT label	Branch if Z clear, and either N set and V set or N clear and V clear (greater than)
1101	BLE label	BLE label	Branch if Z set, or N set and V clear, or N clear and V set (less than or equal)

NOTES:

1. While label specifies a full 9-bit two's complement address, this must always be half-word-aligned (ie with bit 0 set to 0) since the assembler actually places label >> 1 in field SOffset8.
2. Cond = 1110 is undefined, and should not be used.
Cond = 1111 creates the SWI instruction: see .

INSTRUCTION CYCLE TIMES

All instructions in this format have an equivalent ARM instruction as shown in Table 3-23. The instruction cycle times for the THUMB instruction are identical to that of the equivalent ARM instruction.

EXAMPLES

```

        CMP R0, #45           ; Branch to over-if R0 > 45.
        BGT over             ; Note that the THUMB opcode will contain
        .                   ; the number of half-words to offset.
        .
        over                 ; Must be half-word aligned.

```

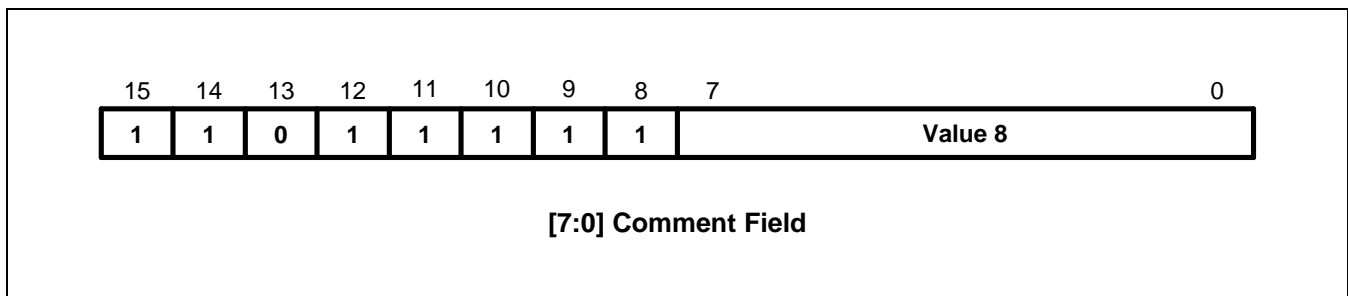
FORMAT 17: SOFTWARE INTERRUPT**Figure 3-46. Format 17****OPERATION**

The SWI instruction performs a software interrupt. On taking the SWI, the processor switches into ARM state and enters Supervisor (SVC) mode.

The THUMB assembler syntax for this instruction is shown below.

Table 3-24. The SWI Instruction

THUMB assembler	ARM equivalent	Action
SWI Value 8	SWI Value 8	Perform Software Interrupt: Move the address of the next instruction into LR, move CPSR to SPSR, load the SWI vector address (0x8) into the PC. Switch to ARM state and enter SVC mode.

NOTE: Value8 is used solely by the SWI handler; it is ignored by the processor.

INSTRUCTION CYCLE TIMES

All instructions in this format have an equivalent ARM instruction as shown in Table 3-24. The instruction cycle times for the THUMB instruction are identical to that of the equivalent ARM instruction.

EXAMPLES

```
SWI 18 ; Take the software interrupt exception.
        ; Enter Supervisor mode with 18 as the
        ; requested SWI number.
```

FORMAT 18: UNCONDITIONAL BRANCH

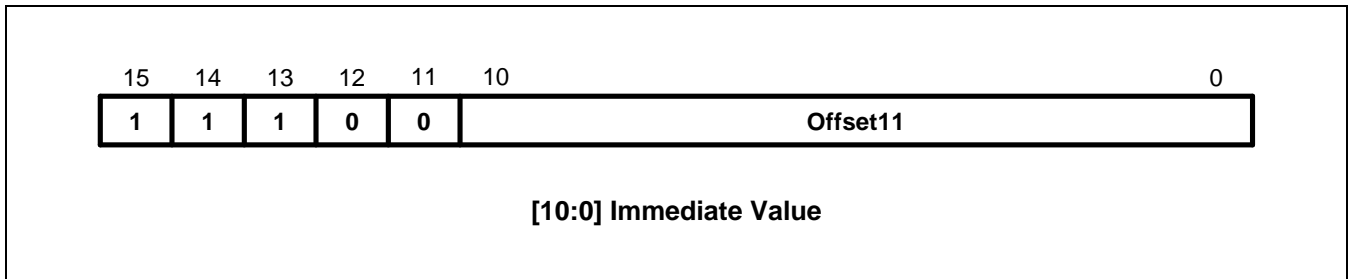

Figure 3-47. Format 18

OPERATION

This instruction performs a PC-relative Branch. The THUMB assembler syntax is shown below. The branch offset must take account of the prefetch operation, which causes the PC to be 1 word (4 bytes) ahead of the current instruction.

Table 3-25. Summary of Branch Instruction

THUMB assembler	ARM equivalent	Action
B label	BAL label (half-word offset)	Branch PC relative +/- Offset11 << 1, where label is PC +/- 2048 bytes.

NOTE: The address specified by label is a full 12-bit two's complement address, but must always be half-word aligned (ie bit 0 set to 0), since the assembler places label >> 1 in the Offset11 field.

EXAMPLES

```

here      B here          ; Branch onto itself. Assembles to 0xE7FE.
          ; (Note effect of PC offset).
          B jimmy        ; Branch to 'jimmy'.
          •              ; Note that the THUMB opcode will contain the number of
          •              ; half-words to offset.
          •              ; Must be half-word aligned.
jimmy     •
    
```

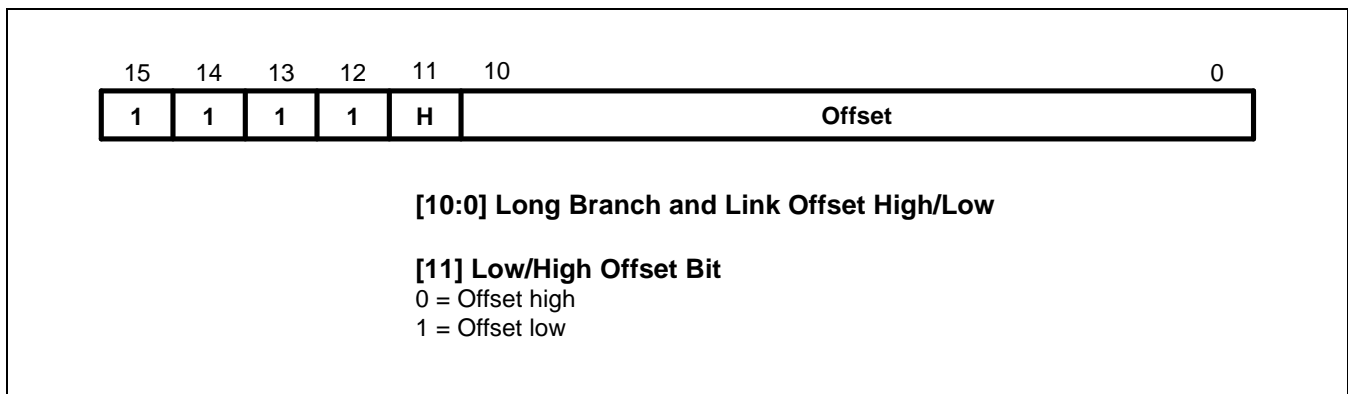
FORMAT 19: LONG BRANCH WITH LINK**Figure 3-48. Format 19****OPERATION**

This format specifies a long branch with link.

The assembler splits the 23-bit two's complement half-word offset specified by the label into two 11-bit halves, ignoring bit 0 (which must be 0), and creates two THUMB instructions.

Instruction 1 (H = 0)

In the first instruction the Offset field contains the upper 11 bits of the target address. This is shifted left by 12 bits and added to the current PC address. The resulting address is placed in LR.

Instruction 2 (H =1)

In the second instruction the Offset field contains an 11-bit representation lower half of the target address. This is shifted left by 1 bit and added to LR. LR, which now contains the full 23-bit address, is placed in PC, the address of the instruction following the BL is placed in LR and bit 0 of LR is set.

The branch offset must take account of the prefetch operation, which causes the PC to be 1 word (4 bytes) ahead of the current instruction

INSTRUCTION CYCLE TIMES

This instruction format does not have an equivalent ARM instruction.

Table 3-26. The BL Instruction

L	THUMB assembler	ARM equivalent	Action
0	BL label	none	LR := PC + OffsetHigh << 12
1			temp := next instruction address PC := LR + OffsetLow << 1 LR := temp 1

EXAMPLES

```

next      BL faraway          ; Unconditionally Branch to 'faraway'
          •                  ; and place following instruction
          •                  ; address, ie "next", in R14,the Link
                                     ; register and set bit 0 of LR high.
                                     ; Note that the THUMB opcodes will
faraway   •                  ; contain the number of half-words to offset.
          •                  ; Must be Half-word aligned.

```

INSTRUCTION SET EXAMPLES

The following examples show ways in which the THUMB instructions may be used to generate small and efficient code. Each example also shows the ARM equivalent so these may be compared.

MULTIPLICATION BY A CONSTANT USING SHIFTS AND ADDS

The following shows code to multiply by various constants using 1, 2 or 3 Thumb instructions alongside the ARM equivalents. For other constants it is generally better to use the built-in MUL instruction rather than using a sequence of 4 or more instructions.

Thumb	ARM	
1. Multiplication by 2^n (1,2,4,8,...)		
LSL	Ra, Rb, LSL #n	; MOV Ra, Rb, LSL #n
2. Multiplication by 2^{n+1} (3,5,9,17,...)		
LSL	Rt, Rb, #n	; ADD Ra, Rb, Rb, LSL #n
ADD	Ra, Rt, Rb	
3. Multiplication by 2^{n-1} (3,7,15,...)		
LSL	Rt, Rb, #n	; RSB Ra, Rb, Rb, LSL #n
SUB	Ra, Rt, Rb	
4. Multiplication by -2^n (-2, -4, -8, ...)		
LSL	Ra, Rb, #n	; MOV Ra, Rb, LSL #n
MVN	Ra, Ra	; RSB Ra, Ra, #0
5. Multiplication by -2^{n-1} (-3, -7, -15, ...)		
LSL	Rt, Rb, #n	; SUB Ra, Rb, Rb, LSL #n
SUB	Ra, Rb, Rt	

Multiplication by any $C = \{2^{n+1}, 2^{n-1}, -2^n \text{ or } -2^{n-1}\} * 2^n$

Effectively this is any of the multiplications in 2 to 5 followed by a final shift. This allows the following additional constants to be multiplied. 6, 10, 12, 14, 18, 20, 24, 28, 30, 34, 36, 40, 48, 56, 60, 62

(2..5)		; (2..5)
LSL	Ra, Ra, #n	; MOV Ra, Ra, LSL #n

GENERAL PURPOSE SIGNED DIVIDE

This example shows a general purpose signed divide and remainder routine in both Thumb and ARM code.

Thumb code

```

;signed_divide                                ; Signed divide of R1 by R0: returns quotient in R0,
                                                ; remainder in R1

;Get abs value of R0 into R3
    ASR    R2, R0, #31                        ; Get 0 or -1 in R2 depending on sign of R0
    EOR    R0, R2                             ; EOR with -1 (0xFFFFFFFF) if negative
    SUB    R3, R0, R2                         ; and ADD 1 (SUB -1) to get abs value

;SUB always sets flag so go & report division by 0 if necessary
    BEQ    divide_by_zero

;Get abs value of R1 by xoring with 0xFFFFFFFF and adding 1 if negative
    ASR    R0, R1, #31                        ; Get 0 or -1 in R3 depending on sign of R1
    EOR    R1, R0                             ; EOR with -1 (0xFFFFFFFF) if negative
    SUB    R1, R0                             ; and ADD 1 (SUB -1) to get abs value

;Save signs (0 or -1 in R0 & R2) for later use in determining ; sign of quotient & remainder.
    PUSH    {R0, R2}

;Justification, shift 1 bit at a time until divisor (R0 value) ; is just <= than dividend (R1 value). To do this shift
;dividend ; right by 1 and stop as soon as shifted value becomes >.
    LSR    R0, R1, #1
    MOV    R2, R3
    B      %FT0
just_l   LSL    R2, #1
0        CMP    R2, R0
        BLS    just_l
        MOV    R0, #0                            ; Set accumulator to 0
        B      %FT0                            ; Branch into division loop

div_l    LSR    R2, #1
0        CMP    R1, R2                            ; Test subtract
        BCC    %FT0
        SUB    R1, R2                            ; If successful do a real subtract
0        ADC    R0, R0                            ; Shift result and add 1 if subtract succeeded

        CMP    R2, R3                            ; Terminate when R2 == R3 (ie we have just
        BNE    div_l                            ; tested subtracting the 'ones' value).

```

Now fixup the signs of the quotient (R0) and remainder (R1)

```

POP      {R2, R3}          ; Get dividend/divisor signs back
EOR      R3, R2            ; Result sign
EOR      R0, R3           ; Negate if result sign = - 1
SUB      R0, R3
EOR      R1, R2           ; Negate remainder if dividend sign = - 1
SUB      R1, R2
MOV      pc, lr

```

ARM Code

signed_divide ; Effectively zero a4 as top bit will be shifted out later

```

ANDS     a4, a1, #&80000000
RSBMI   a1, a1, #0
EORS     ip, a4, a2, ASR #32

```

;ip bit 31 = sign of result

;ip bit 30 = sign of a2

```

RSBCS   a2, a2, #0

```

;Central part is identical code to udiv (without MOV a4, #0 which comes for free as part of signed entry sequence)

```

MOVS     a3, a1
BEQ      divide_by_zero

```

just_l

```

CMP      a3, a2, LSR #1
MOVLS   a3, a3, LSL #1
BLO     s_loop

```

; Justification stage shifts 1 bit at a time

; NB: LSL #1 is always OK if LS succeeds

div_l

```

CMP      a2, a3
ADC      a4, a4, a4
SUBCS   a2, a2, a3
TEQ     a3, a1
MOVNE   a3, a3, LSR #1
BNE     s_loop2
MOV     a1, a4
MOVS    ip, ip, ASL #1
RSBCS   a1, a1, #0
RSBMI   a2, a2, #0
MOV     pc, lr

```

DIVISION BY A CONSTANT

Division by a constant can often be performed by a short fixed sequence of shifts, adds and subtracts.

Here is an example of a divide by 10 routine based on the algorithm in the ARM Cookbook in both Thumb and ARM code.

Thumb Code

```

udiv10                                ; Take argument in a1 returns quotient in a1,
                                        ; remainder in a2
    MOV     a2, a1
    LSR     a3, a1, #2
    SUB     a1, a3
    LSR     a3, a1, #4
    ADD     a1, a3
    LSR     a3, a1, #8
    ADD     a1, a3
    LSR     a3, a1, #16
    ADD     a1, a3
    LSR     a1, #3
    ASL     a3, a1, #2
    ADD     a3, a1
    ASL     a3, #1
    SUB     a2, a3
    CMP     a2, #10
    BLT     %FT0
    ADD     a1, #1
    SUB     a2, #10
0
    MOV     pc, lr

```

ARM Code

```

udiv10                                ; Take argument in a1 returns quotient in a1,
                                        ; remainder in a2
    SUB     a2, a1, #10
    SUB     a1, a1, a1, lsr #2
    ADD     a1, a1, a1, lsr #4
    ADD     a1, a1, a1, lsr #8
    ADD     a1, a1, a1, lsr #16
    MOV     a1, a1, lsr #3
    ADD     a3, a1, a1, asl #2
    SUBS    a2, a2, a3, asl #1
    ADDPL   a1, a1, #1
    ADDMI   a2, a2, #10
    MOV     pc, lr

```

NOTES

4 I/O PORTS

OVERVIEW

S3F443FX has 16 general input/output ports.

- Seven ports are dedicated to being I/O ports only(GPIO[6:0])
- Nine ports are shared with other functional pins (Multiplexed I/O ports :GPIO[15:7])
- Three external interrupt input or output pins

Each port can be easily configured by the software to meet various system configuration and design requirements. The CPU accesses I/O ports by directly writing or reading port register addresses. For this reason, special I/O instructions are not needed.

Table 4-1. S3F443FX Port Configuration Overview

Port	Configuration Options	Programmability
0	General C-MOS push-pull I/O port with pull-up resistor Port 0 consists of GPIO[7:0]. GPIO7 is multiplexed with TIN.	Bit programmable
1	General C-MOS push-pull I/O port with pull-up resistor or pull-down resistor. Port 1 consists of GPIO[15:8]. GPIO[15:8] are multiplexed with RXD, TXD and A[17:12].	Bit programmable
2	External interrupt input or output port	Bit programmable

PORT DATA REGISTERS

Table 4-2. Port Data Register Summary

Register Name	Mnemonic	Offset	Reset Value	R/W
Port 0 Data Register	P0[7:0]	0xb000	xxh	R/W
Port 1 Data Register	P1[7:0]	0xb001	xxh	R/W
Port 2 Data Register	P2[7:0]	0xb002	xxh	R/W

PORT CONTROL REGISTERS TABLE

Table 4-3. Port Control Register Summary

Register Name	Mnemonic	ADDR	Reset Value	R/W
Port 0 Control Register	P0CON	0xb010	00h	R/W
Port 0 Pull-up Register	P0PUR	0xb015	ffh	R/W
Port 1 Control Register	P1CON	0xb012	0000h	R/W
Port 1 Pull-up/down Register	P1PUDR	0xb016	ffh	R/W
Port 2 Control Register	P2CON	0xb014	0h	R/W
Port 2 Pull-up Register	P2PUR	0xb017	7h	R/W
Port 2 External Interrupt Control Register	EINTCON	0xb018	0h	R/W
Port 2 External Interrupt Mode Register	EINTMOD	0xb01a	00h	R/W

Table 4-4. Port 0 Control Register

Name	Bit	Description
P0CON	0	Setting the GPIO[0] bit of Port 0. 0: C-MOS input mode 1: C-MOS push-pull output mode
	1	Setting the GPIO[1] bit of Port 0. 0: C-MOS input mode 1: C-MOS push-pull output mode
	2	Setting the GPIO[2] bit of Port 0. 0: C-MOS input mode 1: C-MOS push-pull output mode
	3	Setting the GPIO[3] bit of Port 0. 0: C-MOS input mode 1: C-MOS push-pull output mode
	4	Setting the GPIO[4] bit of Port 0. 0: C-MOS input mode 1: C-MOS push-pull output mode
	5	Setting the GPIO[5] bit of Port 0. 0: C-MOS input mode 1: C-MOS push-pull output mode
	6	Setting the GPIO[6] bit of Port 0. 0: C-MOS input mode 1: C-MOS push-pull output mode
	7	Setting the GPIO[7] bit of Port 0. 0: TIN / C-MOS input mode 1: C-MOS push-pull output mode
P0PUR	7-0	Setting the GPIO[7:0] pull-up resistor of Port 0. 0: Disable pull-up resistor 1: Enable pull-up resistor

Table 4-5. Port 1 Control Register

Name	Bit	Description
P1CON	1:0	Setting the GPIO[8] bit of Port 1. 00: C-MOS input mode 01: C-MOS push-pull output mode 10: A12
	3:2	Setting the GPIO[9] bit of Port 1. 00: C-MOS input mode 01: C-MOS push-pull output mode 10: A13
	5:4	Setting the GPIO[10] bit of Port 1. 00: C-MOS input mode 01: C-MOS push-pull output mode 10: A14 11: PWM Signal Out
	7:6	Setting the GPIO[11] bit of Port 1. 00: C-MOS input mode 01: C-MOS push-pull output mode 10: A15
	9:8	Setting the GPIO[12] bit of Port 1. 00: C-MOS input mode 01: C-MOS push-pull output mode 10: A16
	11:10	Setting the GPIO[13] bit of Port 1. 00: C-MOS input mode 01: C-MOS push-pull output mode 10: A17
	13:12	Setting the GPIO[14] bit of Port 1. 00: C-MOS input mode 01: C-MOS push-pull output mode 10: TXD
	15:14	Setting the GPIO[15] bit of Port 1. 00: RXD / C-MOS input mode 01: C-MOS push-pull output mode
P1PUDR	5-0	Setting the GPIO[13:8] pull-down resistor of Port 1. 0: Disable pull-down resistor 1: Enable pull-down resistor (When P1 is set as an address line, the pull-down resistor is automatically disabled.)
	7-6	Setting the GPIO[15:14] pull-up resistor of Port 1. 0: Disable pull-up resistor 1: Enable pull-up resistor

Table 4-6. Port2 Control Register

Name	Bit	Description
P2CON	2-0	Setting the EINT[2:0] bit of Port 2. 0: Input or external interrupt input(EINT2:0) 1: C-MOS push-pull output mode
P2PUR	2-0	Setting the EINT[2:0] pull-up resistor of Port 2. 0: Disable pull-up resistor 1: Enable pull-up resistor
EINTMOD	1,0	Setting the external interrupt mode of EINT0 00: Falling edge interrupt enable 01: Rising edge interrupt enable 10: High level interrupt enable 11: Low level interrupt enable
	3,2	Setting the external interrupt mode of EINT1 00: Falling edge interrupt enable 01: Rising edge interrupt enable 10: High level interrupt enable 11: Low level interrupt enable
	5,4	Setting the external interrupt mode of EINT2 00: Falling edge interrupt enable 01: Rising edge interrupt enable 10: High level interrupt enable 11: Low level interrupt enable
EINTCON	2-0	Setting the EINT[2:0] interrupt enable 0: Disable External Interrupt 1: Enable External Interrupt

NOTES

5

BASIC/WATCHDOG TIMER

OVERVIEW

The S3F443FX has an internal Basic Timer/Watch-Dog Timer. This timer can be used to resume controller operation when it has been disturbed due to noise or other kinds of system error or malfunctions. To configure the Watch-dog timer, the overflow signal from the 8-bit Basic timer should be fed to the clock input of the 3-bit Watch-dog timer, as shown in figure below. User can enable or disable the Watch-dog by software, i.e., by controlling the configuration in BTCON register. If the user does not want to configure the Watch-dog timer, the 8-bit Basic timer can be used as a normal interval timer to request interrupt services. It also can signal the end of the required oscillation interval after a reset or a Stop mode release. For example, the Basic timer can give the overflow signal to necessary logic blocks after a reset or release from Stop mode. In this case, the overflow signal from Basic timer may mean that there is a stable clock from an external oscillator circuit.

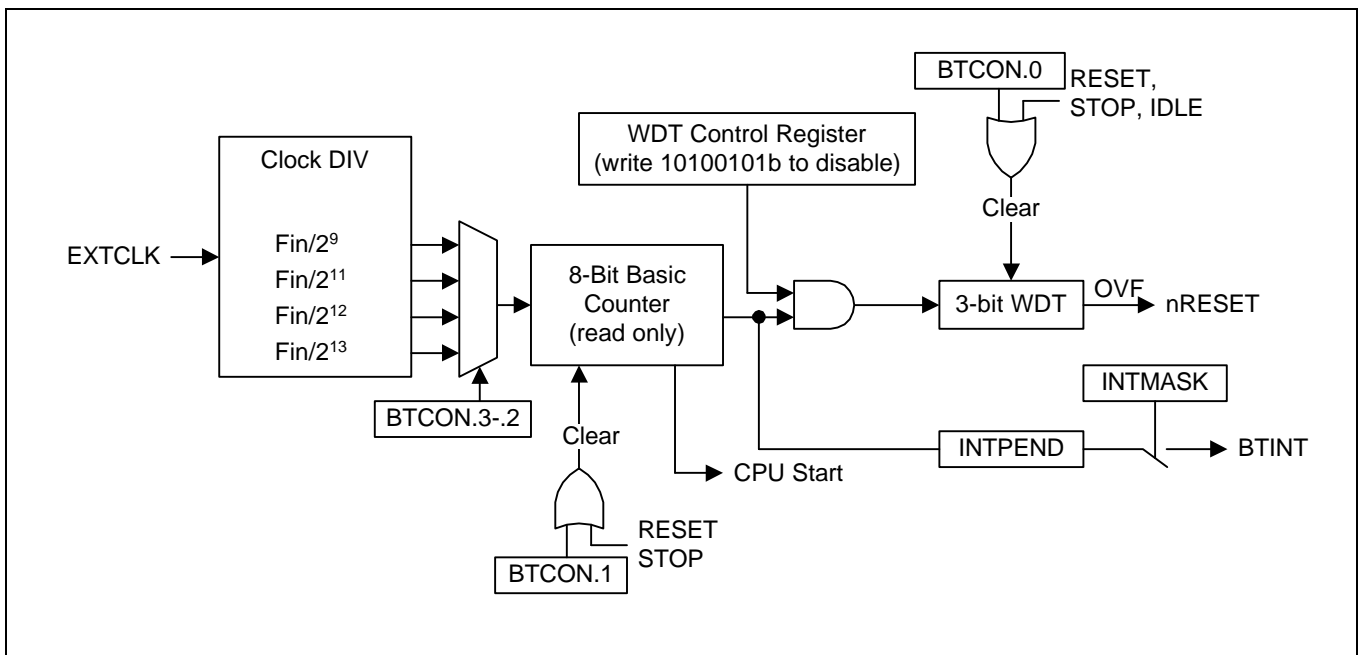

Figure 5-1. Watch-dog Timer Block Diagram

BASIC TIMER COUNTER REGISTER

The basic timer counter register, BTCNT(Offset address : 0xa007), is used to specify the time out duration, and is a free-running 8-bit counter. The table below should be kept as reference for determining the duration of timer. This is the case when the external clock is 20Mhz.

Register	Offset Address	R/W	Description	Reset Value
BTCNT	0xa007	R	Basic timer count register	00h

Table 5-1. Basic Timer Counter Setting (at EXTCLK = 20 MHz)

BTCON.3	BTCON.2	Clock Source	Resolution	Interval Time	Max. Interval
0	0	EXTCLK/2 ¹³	409.6 μs	2 ¹³ / EXTCLK × 2 ⁸	104.86 ms
0	1	EXTCLK /2 ¹²	204.8 μs	2 ¹² / EXTCLK × 2 ⁸	52.43 ms
1	0	EXTCLK /2 ¹¹	102.4 μs	2 ¹¹ / EXTCLK × 2 ⁸	26.21 ms
1	1	EXTCLK /2 ⁹	25.6 μs	2 ⁹ / EXTCLK × 2 ⁸	6.55 ms

EXTERNAL OSCILLATION STABILIZATION TIME AFTER STOP OR RESET

In Figure 5-1, the CPU Start signal after reset or STOP is activated just after the 8-bit basic timer bit 4 is set to 1. So, there is delay time before CPU is started after RESET or STOP is released. This delay time may be used for the oscillation time of an external clock source. This delay time is calculated as in Table 5-2.

Table 5-2. The Delay Time before CPU Time Start (at EXTCLK = 20 MHz)

BTCON.3	BTCON.2	Clock Source	WDT Interval	Delay Time
0	0	EXTCLK/2 ¹³	2 ¹³ / EXTCLK × 2 ⁴	6.55 ms
0	1	EXTCLK /2 ¹²	2 ¹² / EXTCLK × 2 ⁴	3.28 ms
1	0	EXTCLK /2 ¹¹	2 ¹¹ / EXTCLK × 2 ⁴	1.64 ms
1	1	EXTCLK /2 ⁹	2 ⁹ / EXTCLK × 2 ⁴	0.41 ms

WATCH DOG TIMER COUNTER

The watch dog timer counter register, WTCNT, is used to specify the time out duration and is a free-running 3-bit counter. To enable Watch-dog timer, user should write the data in BTCON[15:8] register except 0xA5, which will disable the Watch-dog timer. After writing a value in the BTCON[15:8] register the system will reset if there is an overflow.

Table 5-3. Watch Dog Timer Counter Setting (at EXTCLK = 20 MHz)

BTCON.3	BTCON.2	Clock Source	Resolution	WDT Interval	Interval Time
0	0	EXTCLK/2 ¹³	409.6 μs	2 ¹³ / EXTCLK × 2 ⁸ × 2 ³	838.86 ms
0	1	EXTCLK /2 ¹²	204.8 μs	2 ¹² / EXTCLK × 2 ⁸ × 2 ³	419.43 ms
1	0	EXTCLK /2 ¹¹	102.4 μs	2 ¹¹ / EXTCLK × 2 ⁸ × 2 ³	209.72 ms
1	1	EXTCLK /2 ⁹	25.6 μs	2 ⁹ / EXTCLK × 2 ⁸ × 2 ³	52.43 ms

BASIC TIMER CONTROL REGISTER

The basic timer control register, BTCON, contains watch-dog counter enable bits, clock input setting bits, and counter clear bit.

Register	Offset Address	R/W	Description	Reset Value
BTCON	0xa002	R/W	Basic Timer Control register	0000h

The basic timer control register has the following bits:

- | | | |
|--------|-------------------------|--|
| [0] | WDT Counter clear bit | This bit clears the watch dog counter. When this bit is set, the Watch-dog counter register will be cleared to zero.(synchronous reset) And this bit will be cleared automatically. |
| [1] | Basic Counter clear bit | This bit clears the basic counter. When this bit is set, the Basic timer counter register will be cleared to all zero.(synchronous reset) And this bit will be cleared automatically. |
| [3:2] | Clock source select | These bits select a clock source.
11b = EXTCLK / 2 ⁹
10b = EXTCLK / 2 ¹¹
01b = EXTCLK / 2 ¹²
00b = EXTCLK / 2 ¹³ |
| [15:8] | Watch dog timer enable | These bits enable or disable the watch-dog timer counting. When these bits are {10100101b}, watch dog timer counter is stopped. The other value enable watch-dog timer counting, and reset the system if there is an overflow. |

FUNCTION DESCRIPTION

INTERVAL TIMER FUNCTION

The primary function of a basic timer is to measure the elapsed time intervals. The standard time interval is equal to 256 basic timer clock pulses.

The content of the 8-bit counter register, BTCNT, increases every time a clock signal corresponding to the BTCON selected frequency is detected. The BTCNT continues its counting until an overflow occurs, i.e., the content reaches 255. An overflow set on the BT interrupt pending flag, which signals elapse of the designated time interval. Then, an interrupt request is generated; BTCNT is cleared to all zero; and the counting continues from 00H, again.

Watchdog Timer Function

The basic timer can also be used as a "watch-dog" timer to detect an unexpected program sequence, that is, a system or program operation error due to an external factor. For example, an external noise can create an this type of error in which the CPU is running an unexpected code sequence, i.e., malfunction of CPU. To recover the CPU from the unexpected sequence, the watch-dog timer should reset the CPU for malfunctions. But, during normal sequence, the instruction, which clears the watch-dog timer within a given period, should be executed at proper points in a program. If an instruction that clears the watch-dog timer is not executed within the specified period, meaning an overflow of the watch-dog timer, the reset signal should be generated and the system should be restarted with reset status. An operation of watch-dog timer is as follows:

- Each time BTCNT overflows, an overflow signal should be sent to the watch-dog timer counter, WDTCNT.
- If WDTCNT overflows, the system reset should be generated.

A reset signal clears the BTCON as #0000H. This value can enable the watch-dog timer because it is not 0xA5. During the normal operation, the application program should prevent the overflow. To do this, the WDTCNT value should be cleared (by writing a "1" to BTCON.0) at regular intervals before the overflow occurs.

NOTE

In order to save current consumption, Basic Timer counter is stop by register setting, which is SYSCON.bit6, default mode '0' is enable to run Basic Timer Counter. For stopping it, SYSCON.bit6 is to be set '1'.

6

TIMER MODULE 0,1,2,3,4,5 (16-BIT TIMERS)

OVERVIEW

The S3F443FX has Six 16-bit timers:T0,T1,T2,T3,T4 and T5. The timers T0-T5 can operate in interval mode, in capture mode, or in match & overflow mode. The clock source for the timers can be UTCLK or TIN. You can enable or disable the timers by setting the control bits in the corresponding timer mode register.

The timers 0,1,2,3,4, and 5 have three operating modes. The user can select the mode by having the appropriate TnCON setting:

- Interval timer mode
- Capture input mode with a rising or falling edge trigger at the input pin(TIN, which is shared by timer0/1/2/3/4/5)
- Match & Overflow mode

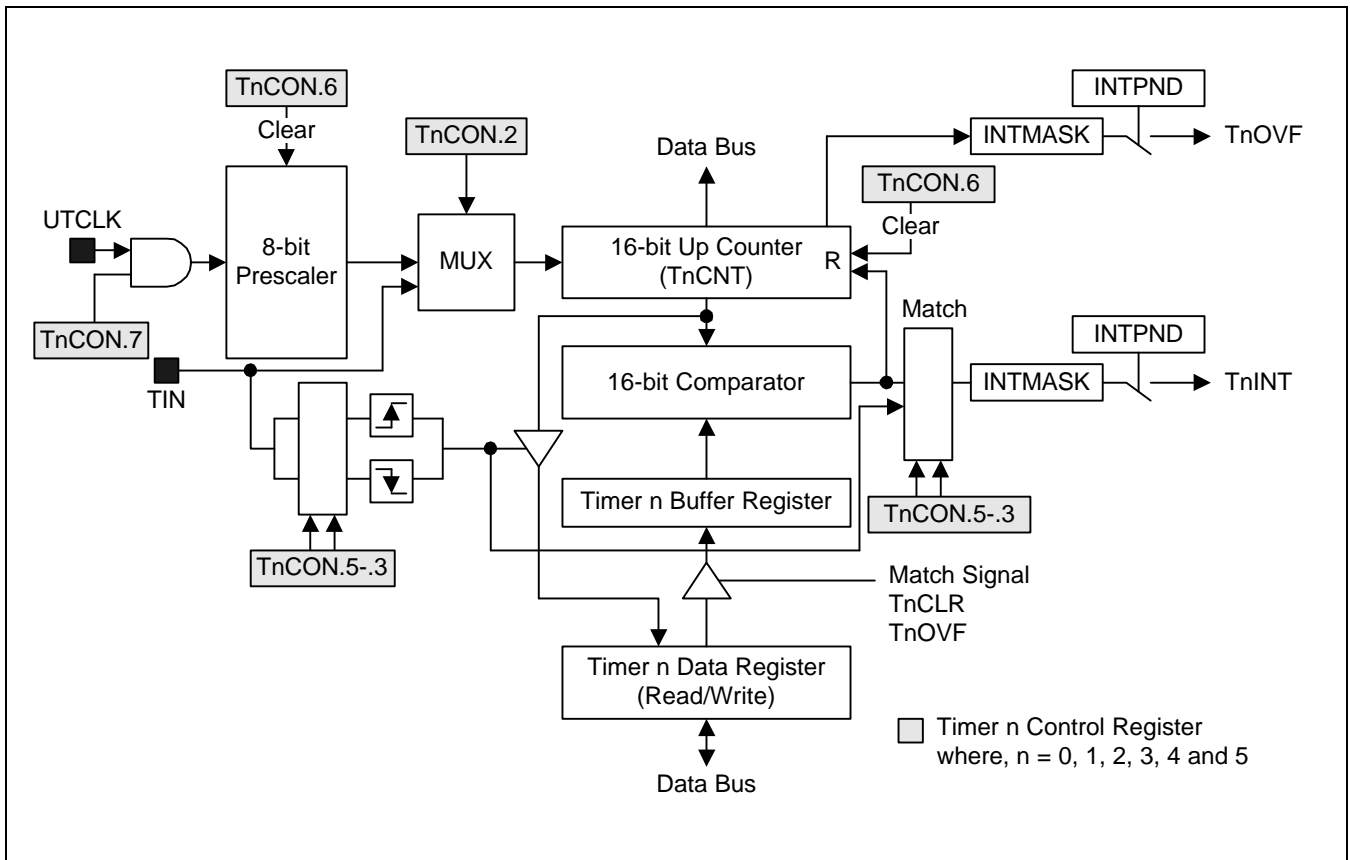

Figure 6-1. 16-Bit Timer Block Diagram

TIMER 0,1,2,3,4,5 CONTROL REGISTERS(T0CON,T1CON,T2CON,T3CON,T4CON,T5CON)

Users should have the configuration on the timer 0,1,2,3,4, and 5 control registers, i.e., TnCON, to determine the following:

- Select the timer n operating mode (interval timer mode, match & overflow mode, or capture mode)
- Select the timer n input clock (UTCLK or TIN)
- Clear the timer n counter, TnCON[6]
- Enable/Disable the timer clock, TnCON[7]

The INTMASK register can control whether the interrupt to CPU should be posted or not when the timer n reaches to the overflow point in the interval timer mode, match & overflow mode, or capture mode. The INTPEND register can store the interrupt pending bit if the corresponding interrupt is not serviced. After the service of interrupt, the S/W should clear the pending bit.

During the system reset, TnCON register is cleared to '00H', automatically, which is a default configuration on the timer. The default configuration is to have the interval timer mode and UTCLK as the timer input clock source. User can clear the timer n counter at any time during normal operation by writing a "1" to TnCON[6].

INTERVAL MODE OPERATION

In interval timer mode, a match signal is generated when the counter value reaches to the written value in the Tn reference data register, TnDATA. The match signal can generate a timer n match interrupt (TnINT) and clear the counter value.

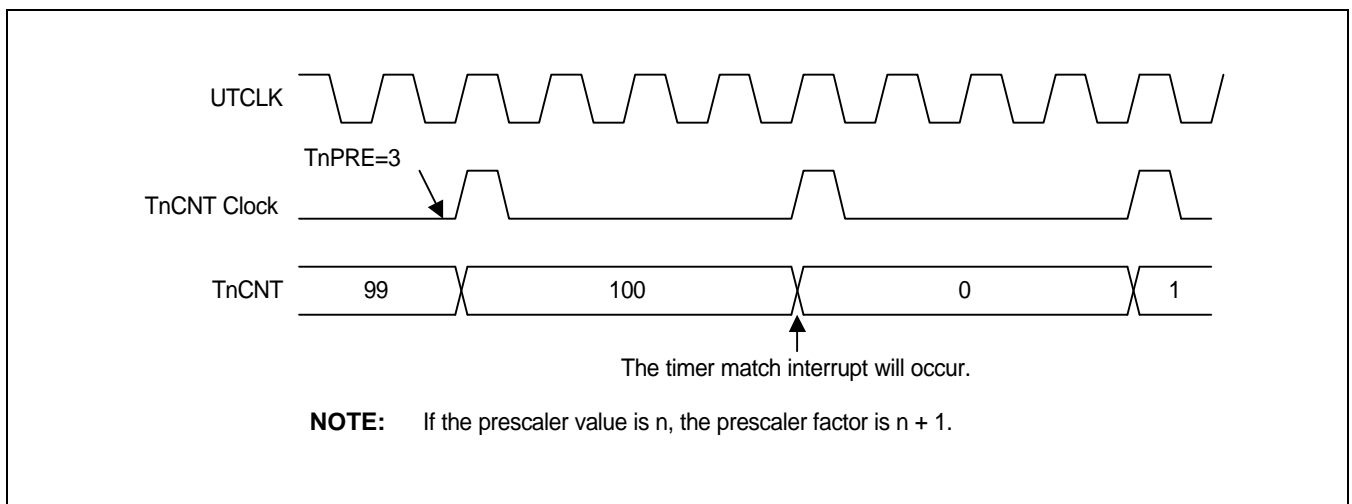

Figure 6-2. Interval Mode Example 1 (TnDATA=100, TnPRE=3, UTCLK is a Timer Source)

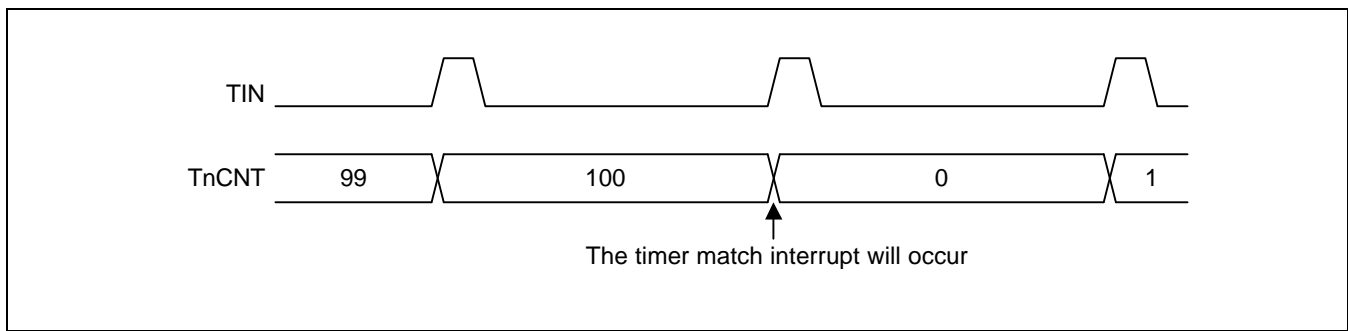

Figure 6-3. Interval Mode Example 2 (TnD ATA=100, TIN is a Timer Source)

CAPTURE MODE OPERATION

In capture mode, the timer performs the capturing operation, in which the current timer counter value in TnCNT register is latched to the timer n data register (TnDATA) in synchronization with an external trigger. For every external trigger signal, the current timer counter value in TnCNT register is latched to the timer n data register (TnDATA) and the capture interrupt is generated. By using this feature, the user can measure the time difference between the external trigger signals. If the TnCNT overflows, the overflow interrupt will be sent to the CPU core. A valid edge detected at the capture input pin is used as the external trigger. When this overflow happens, the timer counter starts its counting from 0000H.

MATCH & OVERFLOW MODE OPERATION

In match mode, the match signal is generated when the timer counter value (TnCNT) is identical to the value of the timer n data register (TnDATA), which was written by S/W. However, the match signal does not clear the counter and can generate a match interrupt, only. It runs continuously, overflowing at FFFFH, and then continues the increment from 0000H. When an overflow happens, an overflow interrupt is also generated.

TIMER SPECIAL REGISTERS

TIMER CONTROL REGISTERS

The timer control registers, T0CON, T1CON, T2CON, T3CON, T4CON, and T5CON are used to control the operations of the six 16-bit timers.

Register	Offset Address	R/W	Description	Reset Value
T0CON	0x9003	R/W	Timer 0 control register	00h
T1CON	0x9013	R/W	Timer 1 control register	00h
T2CON	0x9023	R/W	Timer 2 control register	00h
T3CON	0x9033	R/W	Timer 3 control register	00h
T4CON	0x9043	R/W	Timer 4 control register	00h
T5CON	0x9053	R/W	Timer 5 control register	00h

Three timer mode registers have the following control settings:

- | | | |
|-------|----------------------------|--|
| [2] | Clock source selection | This bit determines which clock source should be used as a timer input clock for the corresponding timer. When this bit is 0, UTCLK should be used as the timer clock source of the corresponding timer. When 1, TIN should be used. |
| [5:3] | Timer mode selection | This field determines the operation mode of the corresponding timer to be used(Interval, match & overflow mode, and capture mode) When the user sets TnCON[5:3] to 000b, the corresponding timer runs in the interval mode. When 001b, the corresponding timer runs in the match & overflow mode. When the user sets TnCON[5:3] to 1xx, the corresponding timer runs in the capture mode. When 100b, the corresponding timer runs in the capture and the capturing will happen at the falling edge of external triggering signal (TIN). When 101b, the corresponding timer runs in the capture mode with the capturing at the rising edge of external triggering signal (TIN). When 110b, the corresponding timer runs in the capture mode with the capturing at both edges of the external triggering signal(TIN). |
| [6] | Counter Clear bit | This bit can clear the counter register(TnCNT). When this bit is set the counter is cleared. Also, this bit is cleared automatically |
| [7] | Timer clock enable/disable | User can enable or disable the timer clock by setting or clearing this bit. When TnCON[7] is 1, the divided UTCLK will be asserted to the 16-bit up-counter through the MUX. Otherwise, the divided UTCLK will not be fed. However, TIN will not be controlled by this bit. Although TnCON[7] is 0, the TIN will make the counter count. |

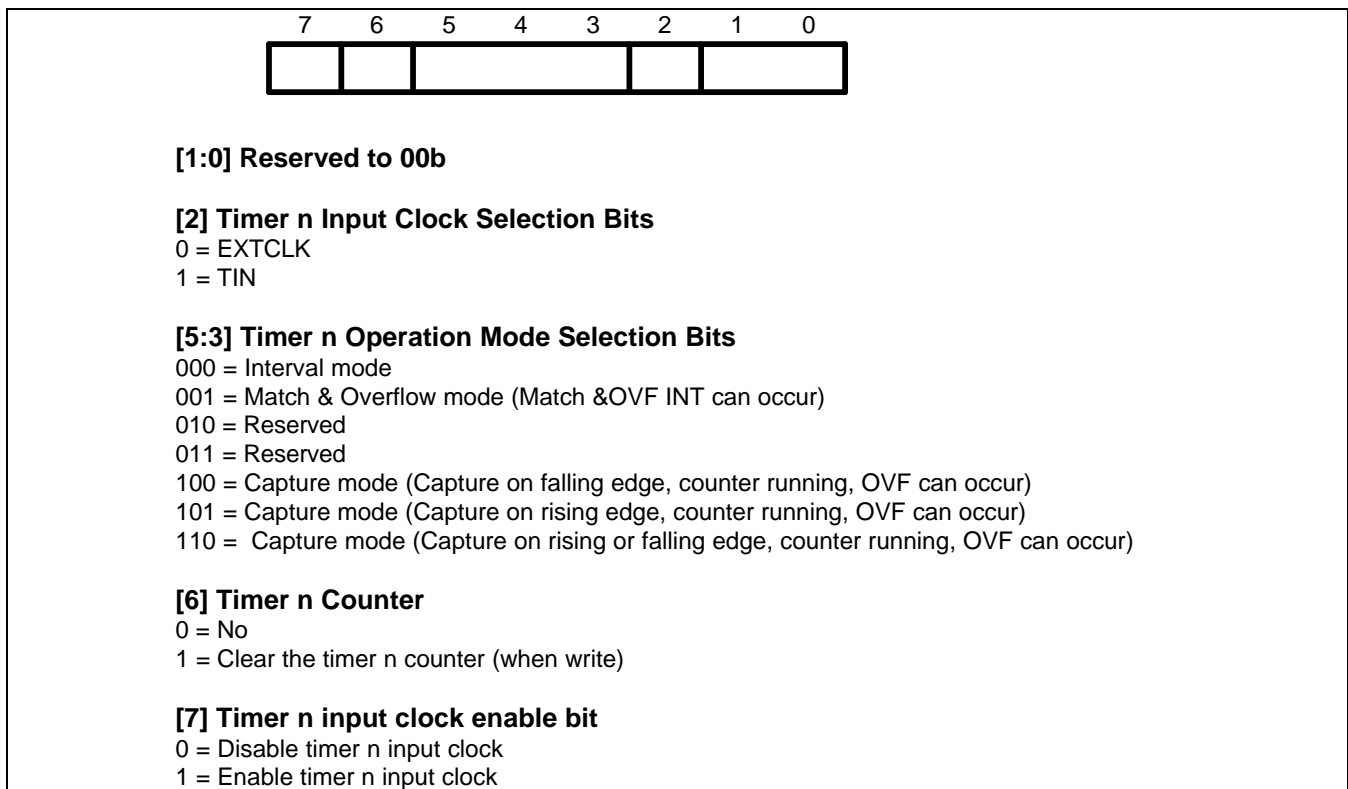

Figure 6-4. Timer 0,1,2,3,4,5 Control Registers

TIMER DATA REGISTERS

The timer data registers, T0DATA, T1DATA, T2DATA, T3DATA, T4DATA and T5DATA, contain values that specify the time-out duration for each timer. The formula for calculating time-out duration is (Timer data + 1) cycles. See Figure 6-5 below.

Register	Offset Address	R/W	Description	Reset Value
T0DATA	0x9000	R/W	Timer 0 data register	ffffh
T1DATA	0x9010	R/W	Timer 1 data register	ffffh
T2DATA	0x9020	R/W	Timer 2 data register	ffffh
T3DATA	0x9030	R/W	Timer 3 data register	ffffh
T4DATA	0x9040	R/W	Timer 4 data register	ffffh
T5DATA	0x9050	R/W	Timer 5 data register	ffffh

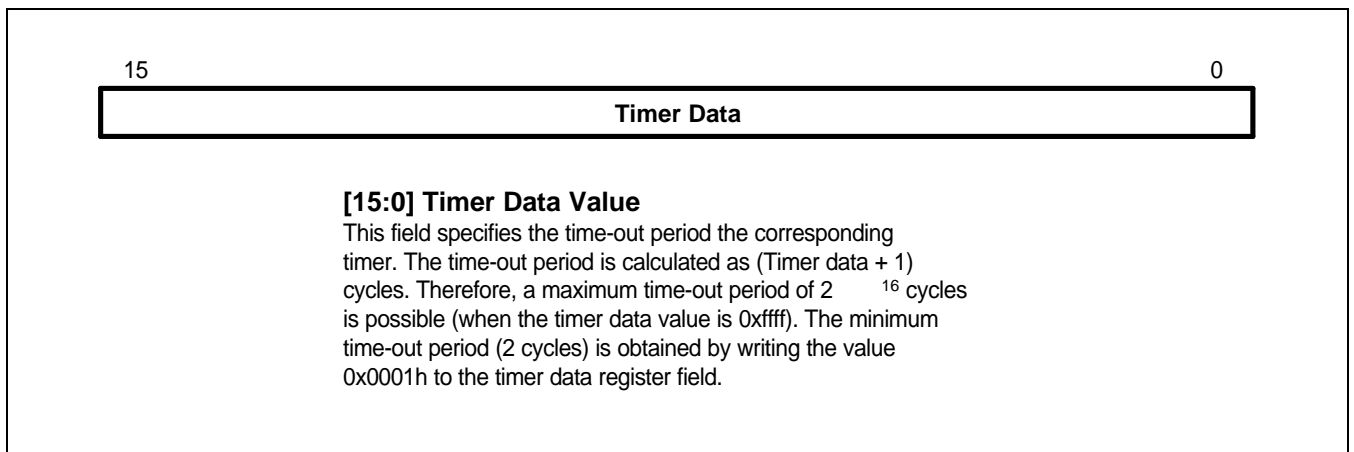

Figure 6-5. Timer Data Registers (TnDATA)

TIMER COUNT REGISTERS

The timer count registers, T0CNT, T1CNT, T2CNT, T3CNT, T4CNT and T5CNT, have values which provides the count value to the current timers 0,1,2,3,4, and 5 during normal operation, respectively (see Figure 6-6).

Register	Offset Address	R/W	Description	Reset Value
T0CNT	0x9006	R	Timer 0 count register	0000h
T1CNT	0x9016	R	Timer 1 count register	0000h
T2CNT	0x9026	R	Timer 2 count register	0000h
T3CNT	0x9036	R	Timer 3 count register	0000h
T4CNT	0x9046	R	Timer 4 count register	0000h
T5CNT	0x9056	R	Timer 5 count register	0000h

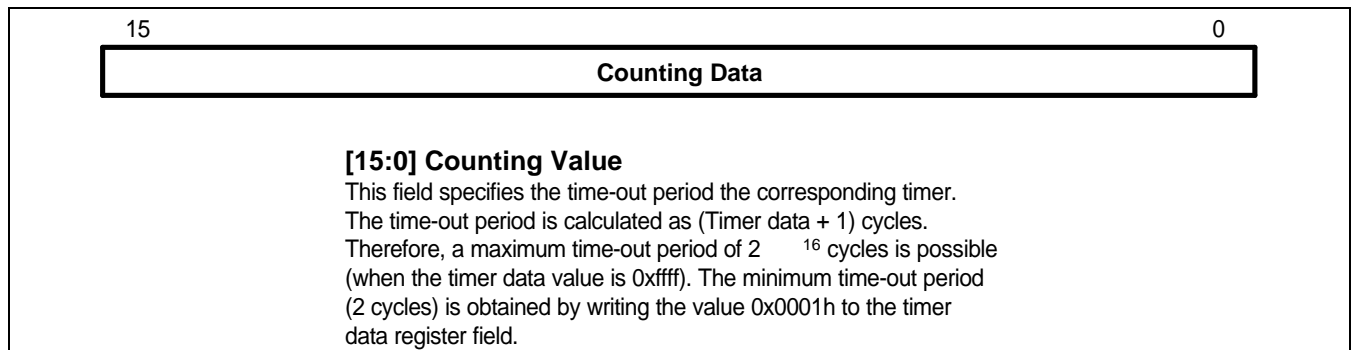

Figure 6-6. Timer Count Registers (TnCNT)

TIMER PRE-SCALER REGISTERS

The timer pre-scaler registers, T0PRE, T1PRE, T2PRE, T3PRE, T4PRE, and T5PRE, have values which provide the pre-scaler values (The main clock should be divided by the pre-scaler factor, which is the timer input clock) to current timers 0/1/2/3/4/5 during normal operation, respectively(see Figure 6-7).

Register	Offset Address	R/W	Description	Reset Value
T0PRE	0x9002	R/W	Timer 0 pre-scaler register	ffh
T1PRE	0x9012	R/W	Timer 1 pre-scaler register	ffh
T2PRE	0x9022	R/W	Timer 2 pre-scaler register	ffh
T3PRE	0x9032	R/W	Timer 3 pre-scaler register	ffh
T4PRE	0x9042	R/W	Timer 4 pre-scaler register	ffh
T5PRE	0x9052	R/W	Timer 5 pre-scaler register	ffh

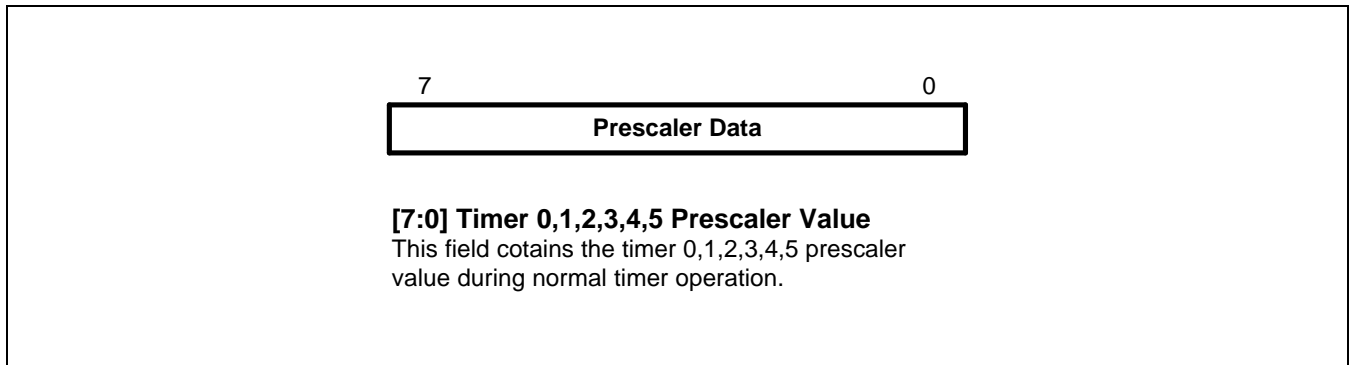

Figure 6-7. Timer Pre-scaler Registers (TnPRE)

A pre-scaler register has an 8-bit pre-scaler value. If the pre-scaler value is n, the prescaler factor is n+1.

NOTES

7

UART

OVERVIEW

The S3F443FX has an on-chip UART (Universal Asynchronous Receiver/Transmitter) block. The UART can be operated in the interrupt-based mode

A UART has a programmable baud rate generator with Rx and Tx ports for UART communication, Tx and Rx shift registers, Tx and Rx buffer registers, Tx and Rx control blocks and control registers. In other words the UART in S3F443FX supports the programmable baud rate, simultaneous transmit/receive(Full duplex mode), one or two stop bit insertion, 5-bit, 6-bit, 7-bit, or 8-bit data transmit/receive size, and parity checking capability.

The baud rate generator can generate the suitable bit rate by dividing EXTCLK. The bit rate is fully programmable by S/W with an appropriate clock division factor, the programmable baud generator can generate UART bit rates 1200, 2400, 4800, 9600, and so on. The transmitter and the receiver block have Tx and Rx data buffer registers, and a Tx and a Rx shift register, respectively. The transmission data should be written to the Tx buffer register, then copied to the Tx shift register, and shifted out through the transmit data pin(Tx). The data to be received should be shifted in through the receive data pin(Rx), and then copied from shift register to the Rx buffer register whenever one data byte is received. The control unit provides the selection on UART operation mode and shows the status/interrupt generation of UART during operation.

NOTE

In order to save current consumption, the operation of UART is stopped by register setting, which is SYSCON.bit7, default mode '0' is enabled to make UART work. For stopping it, SYSCON.bit7 is to be set '1'.

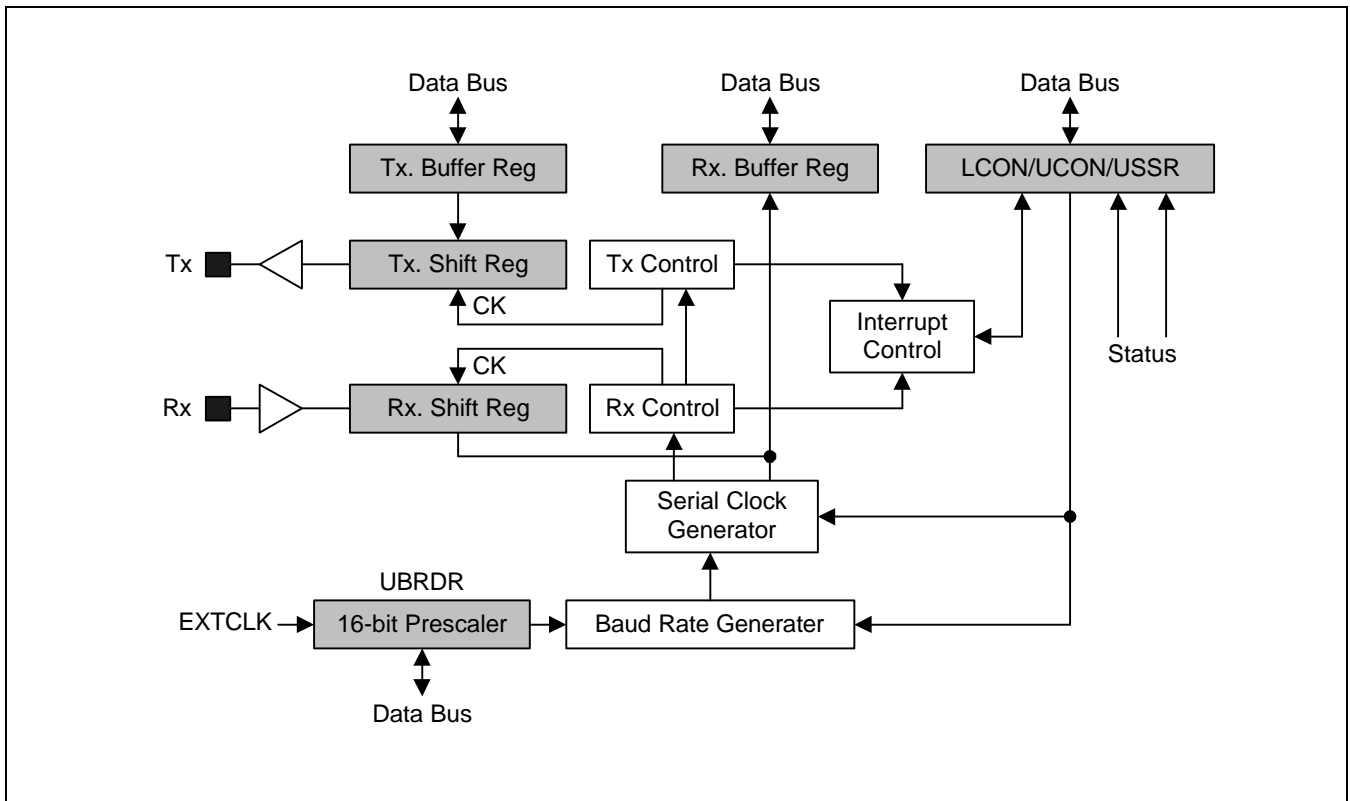

Figure 7-1. UART Block Diagram

INFRA-RED MODE

The S3F443FX UART block can support the infra-red (IR)-based transmit and receive (IrDA 1.0), which can be selected by setting the infra-red-mode bit in the line control register (LCON). The implementation of the mode is shown in Figure 7-2.

In IrDA mode, the transmitted bit data is slightly different from the normal transmitted bit data. In normal transmitted bit data, the high value (Logic 1) will be maintained during one bit time if the bit data is 1. Otherwise, the low value (Logic 0) will be maintained during one bit time if the bit data is 0. In IrDA mode, however, the high value (Logic 1) will be pulsed with the duty of 3/16 during one bit time if the bit data is 1. Otherwise, the low value (Logic 0) will be maintained during one bit time if the bit data is 0. Similarly with Tx case of IrDA mode, the bit data of Rx has same bit shape as Tx. In other words, the receiver should detect the 3/16 pulsed-duty signal when the bit data is 1. The normal operation of Rx is as same as the that of Tx in terms of bit shaping during one bit time.

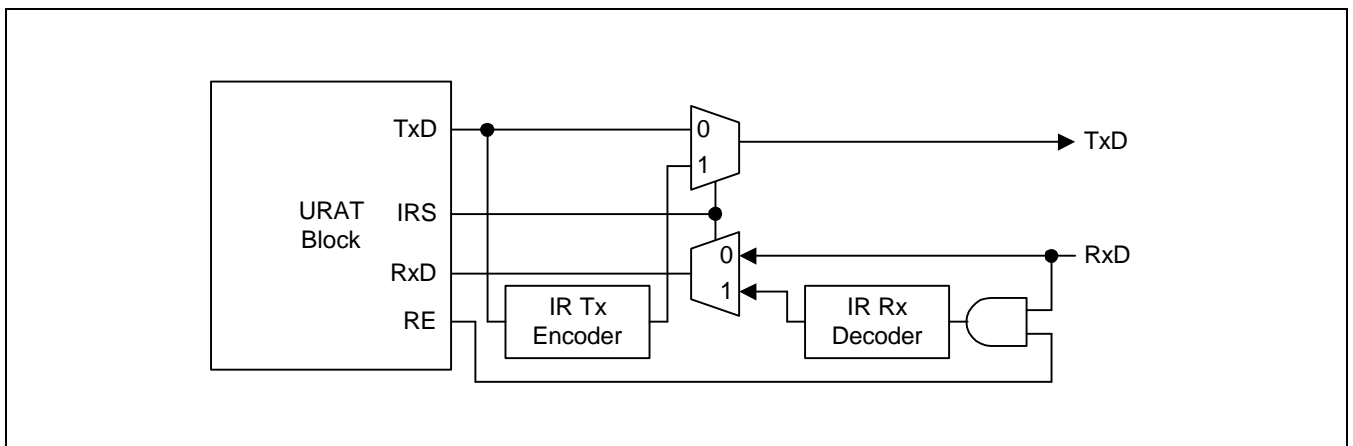

Figure 7-2. Infra-red Mode

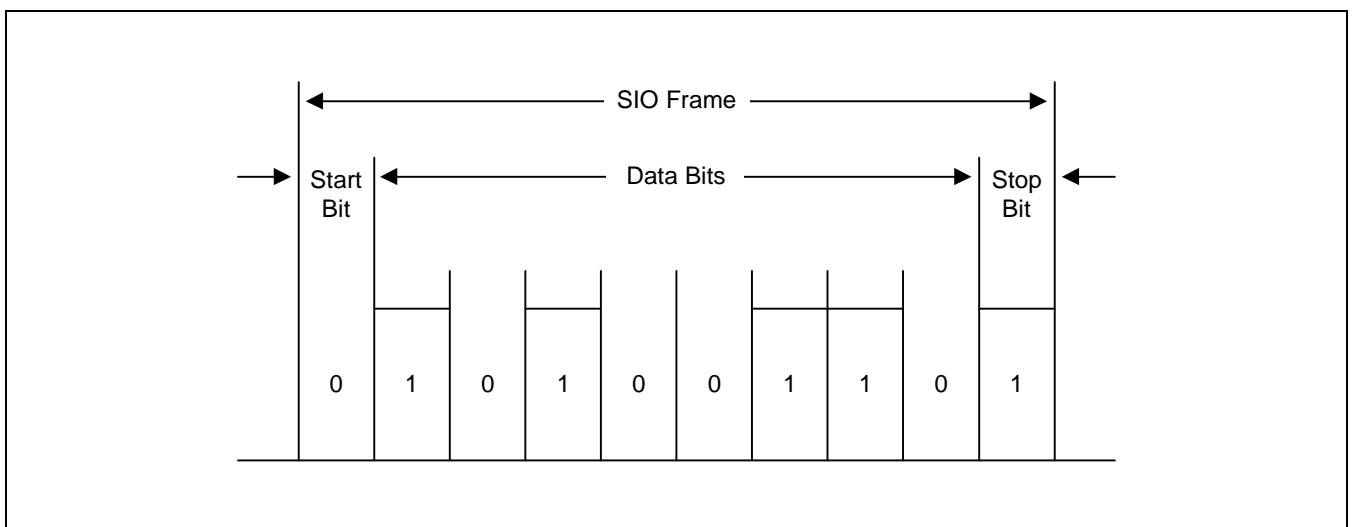

Figure 7-3. Serial I/O Frame Timing Diagram (Normal UART)

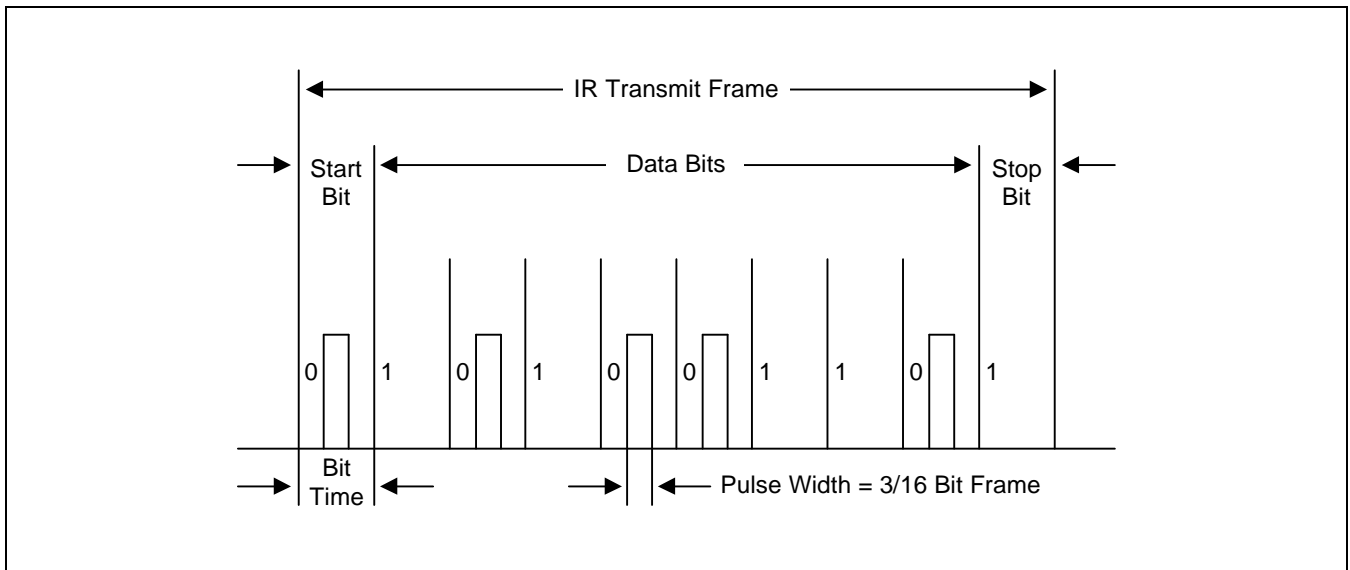

Figure 7-4. Infra-Red Transmit Mode Frame Timing Diagram

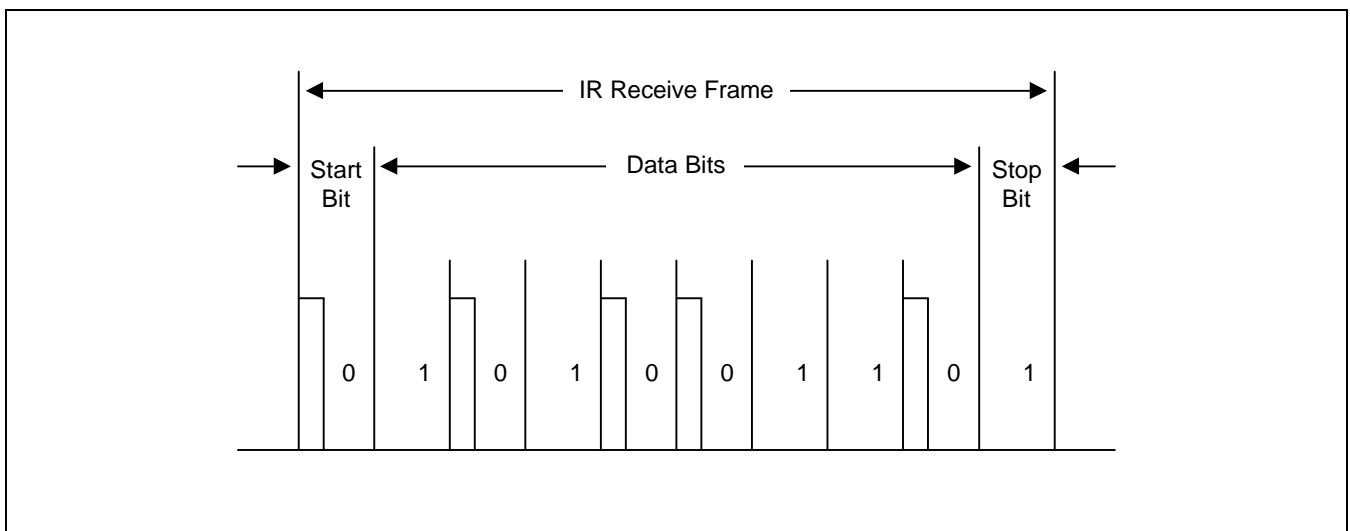

Figure 7-5. Infra-Red Receive Mode Frame Timing Diagram

UART SPECIAL REGISTERS

UART LINE CONTROL REGISTER

The UART Line control register, LCON, is used to control the UART.

Register	Offset Address	R/W	Description	Reset Value
LCON	0x5003	R/W	UART line control register	00h

[1:0]	Word length (WL)	The two-bit word length value indicates the number of data bits to be transmitted or received per frame. The options are 5-bit, 6-bit, 7-bit, and 8-bit.
[2]	Number of stop bits	LCON[2] specifies how many stop bits should be inserted to signal end-of-frame(EOF). When it is 0, one bit signals the EOF; when it is 1, two bits signal EOF.
[5:3]	Parity mode (PMD)	The 3-bit parity mode value specifies how the parity generation and checking should be performed during UART transmit and receive operations. There are five options (see Figure 7-3).
[6]	Reserved	
[7]	Infra-Red Mode	This bit determines whether or not to use infra-red mode 0 = Normal Mode operation 1 = Infra-red Tx/Rx mode

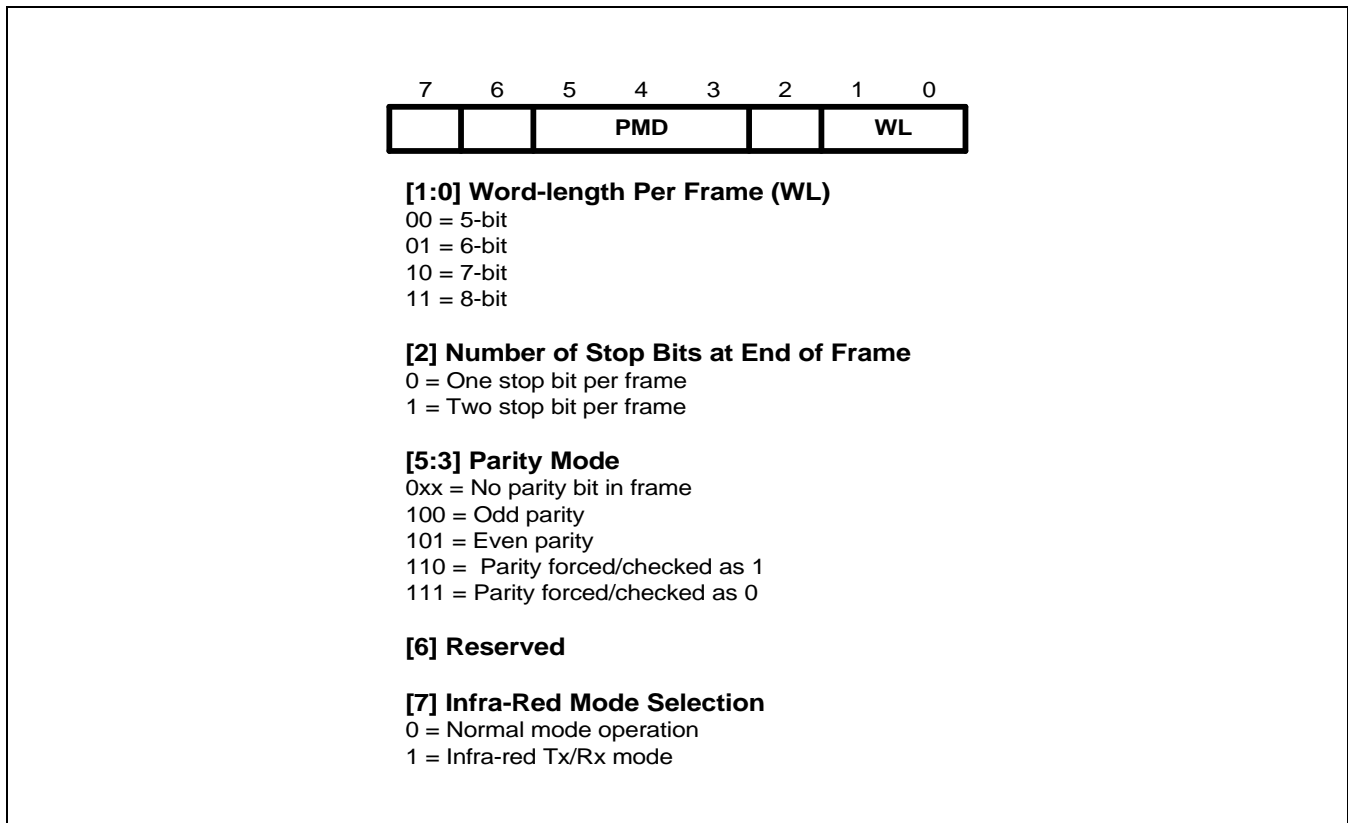

Figure 7-3. UART Line Control Register (LCON)

UART CONTROL REGISTER

The UART control register, UCON, is used to control the single-channel UART.

Register	Offset Address	R/W	Description	Reset Value
UCON	0x5007	R/W	UART control register	00h

[1:0]	Enable receive interrupt	These bits enable the UART to generate a receive interrupt. 00= Disable 01= Interrupt Request or falling mode 10= Reserved 11= Reserved
[2]	Rx status interrupt enable	This bit enables the UART to generate an interrupt if an exception (break, frame error, parity error, or overrun error) occurs during a receive operation. When UCON[2] is set to 1, a receive status interrupt will be generated each time a Rx exception occurs. When UCON[2] is 0, no receive status interrupt will be generated.
[4:3]	Enable transmit interrupt	These bits enable the UART to generate a transmit interrupt. 00= Disable 01= Interrupt Request or falling mode 10= Reserved 11= Reserved
[5]	Reserved	Unknown value will be read.
[6]	Send break	Setting UCON[6] causes the UART to send a break. The break is defined as giving the continuous low level signal on the transmit data output (Tx port) of more than one frame transmission time. When the transmitter is empty (transmitter empty bit, USSR[7] = 1), the exact one-frame time can be obtained by using TBR & USSR registers. When USSR[7] is 1, write dummy data to the transmit buffer register (TBR). Then poll the USSR[7] value. When it returns to 1, clear (reset) the send break bit, UCON[6].
[7]	Loop-back bit	Setting UCON[7] causes the UART to enter into the loop-back mode. In loop-back mode, the transmit buffer register (TBR) is internally connected to the receive buffer register (RBR). This mode is provided for test purposes only.

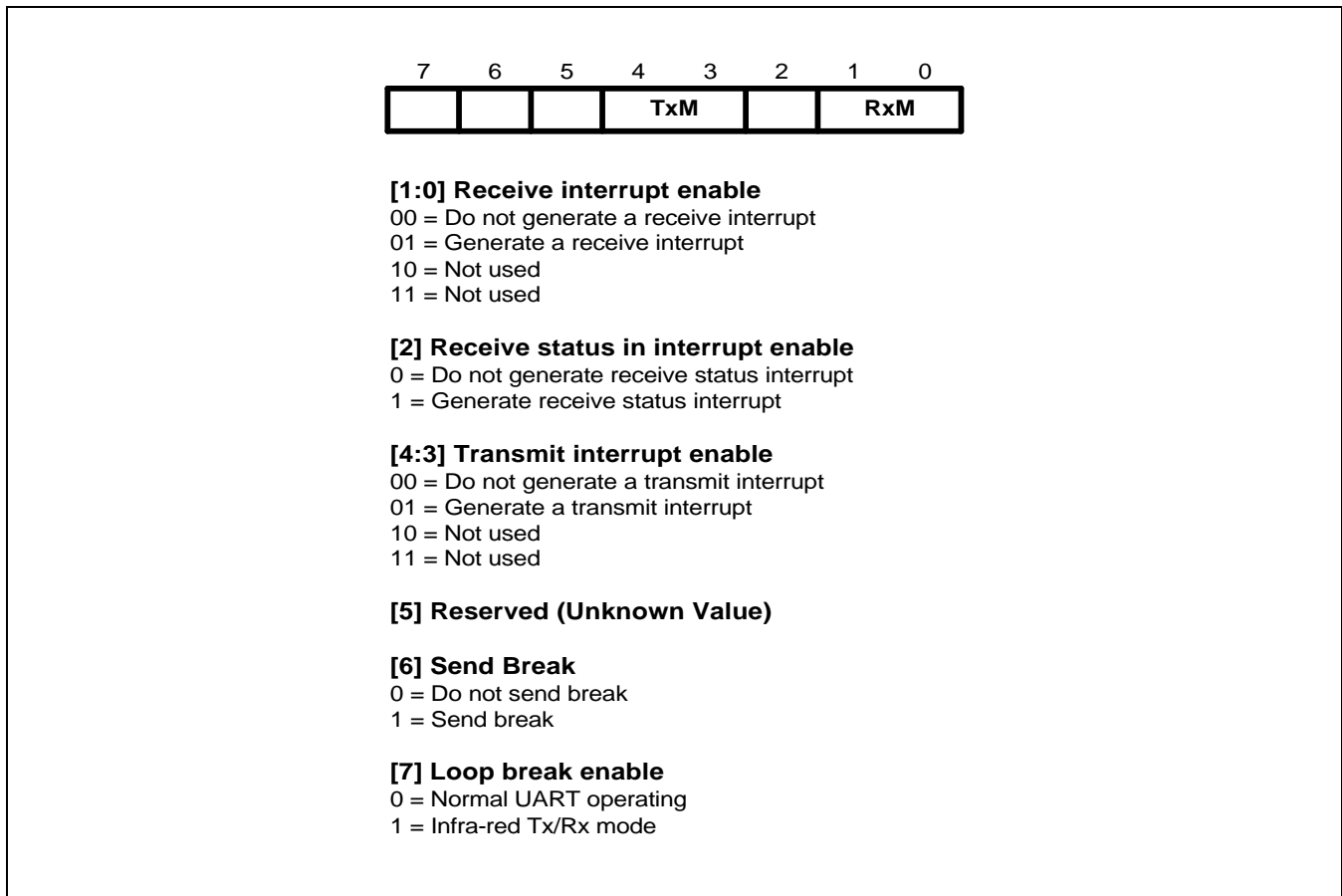

Figure 7-4. UART Control Register (UCON)

UART STATUS REGISTER

The UART status register, USSR, is a read-only register that is used to monitor the status of serial I/O operations in the single-channel UART.

Register	Offset Address	R/W	Description	Reset Value
USSR	0x500b	R	UART status register	c0h

[0]	Overrun error	USSR[0] is automatically set to 1 whenever an overrun error occurs during a serial data receive operation. If the receive status interrupt enable bit UCON[2] is 1, a receive status interrupt will be generated if an overrun error occurs. This bit is automatically cleared to 0 whenever the UART status register (USSR) is read.
[1]	Parity error	USSR[1] is automatically set to 1 whenever a parity error occurs during a serial data receive operation. If the receive status interrupt enable bit UCON[2] is 1, a receive status interrupt will be generated if a parity error occurs. This bit is automatically cleared to 0 whenever the UART status register (USSR) is read.
[2]	Frame error	USSR[2] is automatically set to 1 whenever a frame error occurs during a serial data receive operation. If the receive status interrupt enable bit UCON[2] is 1, a receive status interrupt will be generated if a frame error occurs. The frame error bit is automatically cleared to 0 whenever the UART status register (USSR) is read.
[3]	Break interrupt	USSR[3] is automatically set to 1 to indicate that a break signal has been received. If the receive status interrupt enable bit, UCON[2], is 1, a receive status interrupt will be generated if a break occurs. The break interrupt bit is automatically cleared to 0 when you read the UART status register.
[4]	–	–
[5]	Receive data ready	USSR[5] is automatically set to 1 whenever the receive data buffer register (RBR) contains the valid data received over the serial port. The receive data can then be read from the RBR. When this bit is 0, the RBR does not contain valid data.
[6]	Tx buffer register empty	USSR[6] is automatically set to 1 when the transmit buffer register (TBR) does not contain valid data. In this case, the TBR can be written with the data to be transmitted. When this bit is 0, the TBR contains valid Tx data that has not yet been copied to the transmit shift register. In this case, the TBR cannot be written with new Tx data.
[7]	Transmitter empty (T)	USSR[7] is automatically set to 1 when the transmit buffer register has no valid data to be transmitted and when the Tx shift register is empty. When the transmitter empty bit is 1, it indicates that it can now disable the transmitter function block if necessary.

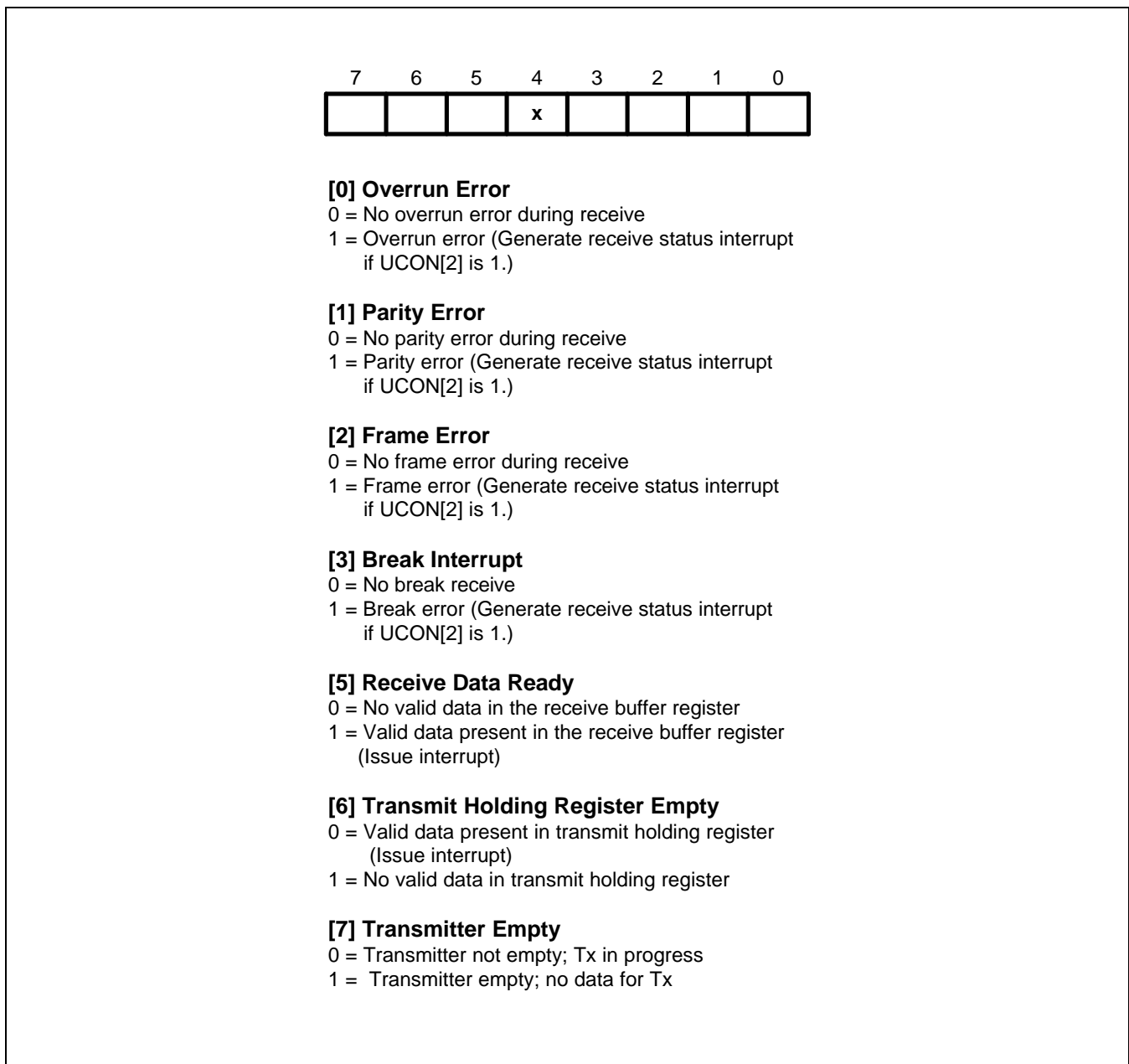

Figure 7-5. UART Status Register (USSR)

UART BAUD RATE PRESCALER REGISTERS

The value in the baud rate prescaler register, UBRDIV, can be used to determine the UART Tx/Rx clock rate(baud rate) as follows:

$$UBRDR = (\text{round_off}) \{ MCLK / (\text{transfer rate} \cdot 16) \} - 1$$

Where the divisor should be from 1 to $(2^{16} - 1)$. For example, if the baud-rate is 115200bps and MCLK is 40MHz, UBRDIV is:

$$\begin{aligned} UBRDR &= (\text{int}) \{ MCLK / (\text{Transfer rate} \cdot 16) + 0.5 \} - 1 \\ &= (\text{int}) \{ 40000000 / (115200 \cdot 16) + 0.5 \} - 1 = (\text{int}) (21.7 + 0.5) - 1 \\ &= 22 - 1 = 21 \end{aligned}$$

Register	Offset Address	R/W	Description	Reset Value
UBRDR	0x5016	R/W	Baud rate divisor register	0000h

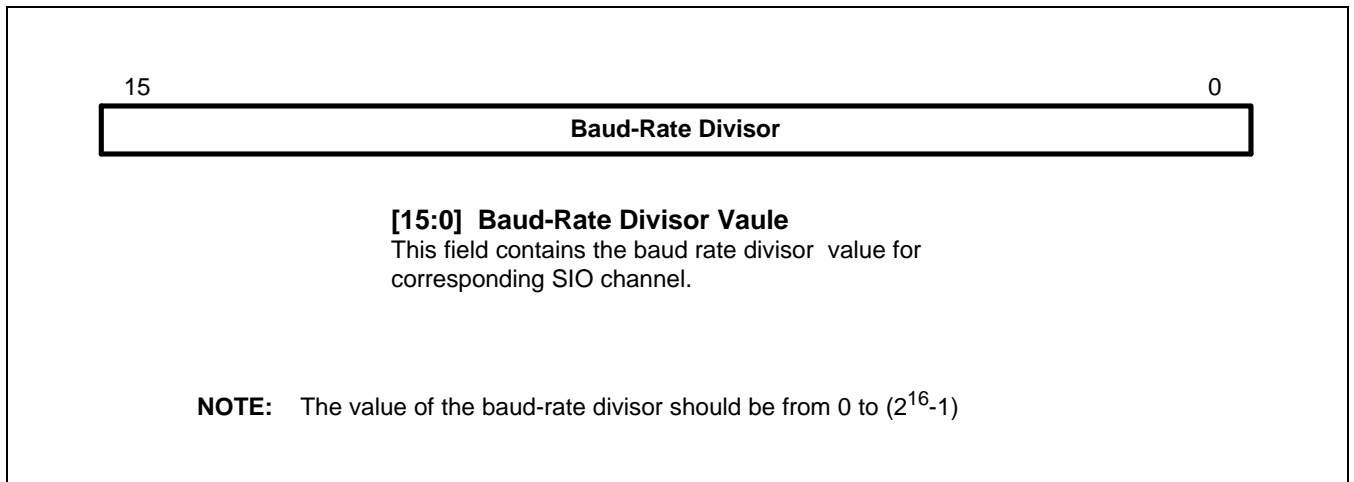

Figure 7-8. UART Baud Rate Divisor Registers (UBRDR)

NOTES

8

INTERRUPT CONTROLLER

OVERVIEW

The S3F443FX interrupt architecture has a total of 21 interrupt sources. Interrupt request can be generated by the internal functional blocks as well as external pins(External Interrupt Request). The ARM7TDMI core can recognize two kinds of interrupt: a normal interrupt request (IRQ) and a fast interrupt request (FIQ). Therefore, all S3F443FX interrupt should be categorized as either IRQ or FIQ. The interrupt sources in S3F443FX can be serviced, delayed, or not be serviced by the combined configuration on the register INTMODE, INTPEND, and INTMASK. To determine the service start address, the S3F443FX can support two kinds of mode. One is a normal interrupt mode and the other is interrupt vector mode. In a case of normal interrupt mode, ARM7TDMI core by H/W checks an interrupt source is which kind of a sort of one IRQ or FIQ and responds an interrupt request to jump PC at the start address of IRQ(0x18) or FIQ(0x1C). Since then, in a program how to serve an interrupt request is decided by user program normally checking the pending bit and the priority among them is also decided by S/W. following the decision of which one to be served, S/W lets PC jump to the real start address of corresponding interrupt request. Meanwhile in a case of vector interrupt mode, the start address is fixed by H/W, regardless that the interrupt source is defined IRQ or FIQ. Which means that the above process by S/W to search for the real start address of interrupt request is automatically performed by H/W. in other words, the H/W can support the respective start address corresponding to each interrupt source. Because it will reduce interrupt latency as possible as it can. To determine the normal interrupt mode or interrupt vector mode, the configuration on interrupt priority register (INTPRIn) is done properly,

- **Interrupt Mode Register:** Defines the interrupt mode, IRQ or FIQ, for each interrupt source.
- **Interrupt Pending Register:** Interrupt pending register indicates that an interrupt request is pending. The interrupt service routine will start if a pending bit is set and the I-flag or F-flag is cleared to 0, However, the pending bit should be cleared before exiting on the interrupt service routine in order to clarify that a requested interrupt service has been finished. As it is known, FIQ interrupt has higher priority than IRQ so that FIQ interrupt request will be served first even if IRQ and IFQ concurrently request Interrupt service.
- **Interrupt Mask Register:** Interrupt mask register indicates that the corresponding interrupt request is not allowable if the corresponding mask bit is 0. If an interrupt mask bit is 1, the interrupt request will be allowable, normally.
- **Interrupt Priority Register:** Interrupt priority register has its own priority level which is defined by suffix 'n' value of INTPRIn and the total number of interrupt priority registers is 21 corresponding to the above mentioned 21 interrupt sources contained in S3F443FX. In other words, S3F443FX has 21 priority levels from 0 to 20 and PRIORITY0 (Level 0) is highest one, while PRIORITY20(Level) is lowest. If you want to assign an interrupt source into a certain priority level, please write the number of interrupt source on targeting interrupt-level register of INTPRIn.

INTERRUPT SOURCES

S3F443FX has 21 interrupt sources, each an interrupt source has own number which is called interrupt number. The followings illustrate specific number and interrupt source.

Sources	Description	Number
INT_URX	UART receive interrupt.	0
INT_UTX	UART transmit interrupt.	1
INT_UERR	UART error.	2
INT_TOF0	Timer 0 Overflow interrupt.	3
INT_TMC0	Timer 0 Match/Capture interrupt	4
INT_TOF1	Timer 1 Overflow interrupt.	5
INT_TMC1	Timer 1 Match/Capture interrupt.	6
INT_TOF2	Timer 2 Overflow interrupt.	7
INT_TMC2	Timer 2 Match/Capture interrupt.	8
INT_TOF3	Timer 3 Overflow interrupt.	9
INT_TMC3	Timer 3 Match/Capture interrupt.	10
INT_TOF4	Timer 4 Overflow interrupt.	11
INT_TMC4	Timer 4 Match/Capture interrupt	12
INT_TOF5	Timer 5 Overflow interrupt.	13
INT_TMC5	Timer 5 Match/Capture interrupt.	14
INT_BT	Basic Timer Interrupt	15
EINT0	EINT0 external interrupt.	16
EINT1	EINT1 external interrupt.	17
EINT2	EINT2 external interrupt.	18
INT_PWMOF	PWM overflow interrupt.	19
INT_PWMMC	PWM match interrupt.	20

INTERRUPT CONTROLLER SPECIAL REGISTERS

INTERRUPT MODE REGISTER (INTMOD)

Bits in the interrupt mode register (INTMODE) determine the interrupt mode of requested interrupt. There are two kinds of interrupt mode, IRQ and FIQ mode. When the bit is set to 1, the corresponding interrupt service should be serviced by FIQ (Fast Interrupt Mode) in ARM7TDMI. Otherwise, the corresponding interrupt service should be serviced by IRQ (Normal Interrupt Request) mode in ARM7TDMI.

NOTE

If the interrupt priority control is enabled, a lower priority interrupt source, which is lower than a higher priority interrupt source configured as IRQ, must not be configured as a FIQ mode.

Register	Offset Address	R/W	Description	Reset Value
INTMODE	0xc000	R/W	Interrupt mode register 0: IRQ mode 1: FIQ mode	xxx0 0000h

INTMOD	BIT	Description		Initial State
INT_URX	[0]	0=IRQ mode	1=FIQ mode	0
INT_UTX	[1]	0=IRQ mode	1=FIQ mode	0
INT_UERR	[2]	0=IRQ mode	1=FIQ mode	0
INT_TOF0	[3]	0=IRQ mode	1=FIQ mode	0
INT_TMC0	[4]	0=IRQ mode	1=FIQ mode	0
INT_TOF1	[5]	0=IRQ mode	1=FIQ mode	0
INT_TMC1	[6]	0=IRQ mode	1=FIQ mode	0
INT_TOF2	[7]	0=IRQ mode	1=FIQ mode	0
INT_TMC2	[8]	0=IRQ mode	1=FIQ mode	0
INT_TOF3	[9]	0=IRQ mode	1=FIQ mode	0
INT_TMC3	[10]	0=IRQ mode	1=FIQ mode	0
INT_TOF4	[11]	0=IRQ mode	1=FIQ mode	0
INT_TMC4	[12]	0=IRQ mode	1=FIQ mode	0
INT_TOF5	[13]	0=IRQ mode	1=FIQ mode	0
INT_TMC5	[14]	0=IRQ mode	1=FIQ mode	0
INT_BT	[15]	0=IRQ mode	1=FIQ mode	0
EINT0	[16]	0=IRQ mode	1=FIQ mode	0
EINT1	[17]	0=IRQ mode	1=FIQ mode	0
EINT2	[18]	0=IRQ mode	1=FIQ mode	0
INT_PWMOF	[19]	0=IRQ mode	1=FIQ mode	0
INT_PWMMC	[20]	0=IRQ mode	1=FIQ mode	0

INTERRUPT PENDING REGISTER (INTPND)

The interrupt pending register (INTPEND) has interrupt pending bits for each interrupt source. When an interrupt request is generated, it will be masked by the CPU if the I-flag or F-flag in the process status register(PSR) is set because of previous interrupt. When a pending bit is set, the interrupt service routine can start whenever the I-flag or F-flag is cleared to 0, which means that the previous service was finished or ARM7TDMI core is ready to accept other interrupts request during the service of previous interrupt request. The service routine should clear the corresponding pending bit by writing 0 when CPU is ready to accept other interrupt request, or when the CPU exit from the corresponding service routine, at least. Because FIQ interrupt has higher priority than IRQ, the FIQ mode interrupt can be serviced before the complete service of IRQ mode interrupt even if the I-bit in PSR is set to 1. In other word, The FIQ mode interrupt request can not be pending, if the IRQ mode interrupt service is on processing.

Register	Offset Address	R/W	Description	Reset Value
INTPEND	0xc004	R/W	Interrupt pending register 0: Clear the corresponding pending bit. 1: Preserve the previous pending bit status.	xxx0 0000h

INTPEND	BIT	Description		Initial State
INT_URX	[0]	0=Not requested	1=Requested	0
INT_UTX	[1]	0=Not requested	1=Requested	0
INT_UERR	[2]	0=Not requested	1=Requested	0
INT_TOF0	[3]	0=Not requested	1=Requested	0
INT_TMC0	[4]	0=Not requested	1=Requested	0
INT_TOF1	[5]	0=Not requested	1=Requested	0
INT_TMC1	[6]	0=Not requested	1=Requested	0
INT_TOF2	[7]	0=Not requested	1=Requested	0
INT_TMC2	[8]	0=Not requested	1=Requested	0
INT_TOF3	[9]	0=Not requested	1=Requested	0
INT_TMC3	[10]	0=Not requested	1=Requested	0
INT_TOF4	[11]	0=Not requested	1=Requested	0
INT_TMC4	[12]	0=Not requested	1=Requested	0
INT_TOF5	[13]	0=Not requested	1=Requested	0
INT_TMC5	[14]	0=Not requested	1=Requested	0
INT_BT	[15]	0=Not requested	1=Requested	0
EINT0	[16]	0=Not requested	1=Requested	0
EINT1	[17]	0=Not requested	1=Requested	0
EINT2	[18]	0=Not requested	1=Requested	0
INT_PWMOF	[19]	0=Not requested	1=Requested	0
INT_PWMMC	[20]	0=Not requested	1=Requested	0

INTERRUPT MASK REGISTER (INTMSK)

The interrupt mask register (INTMASK) has interrupt mask bits for each interrupt source. Each of the interrupt mask register (INTMASK) corresponds to an interrupt source. When an interrupt source mask bit is 0, the interrupt request is not allowed by the CPU when the corresponding interrupt request is generated. If the mask bit is 1, the interrupt is serviced or pending upon request.

Register	Offset Address	R/W	Description	Reset Value
INTMASK	0xc008	R/W	Interrupt mask register 0: Disable the corresponding interrupt. 1: Enable the corresponding interrupt.	xxx0 0000h

INTMSK	BIT	Description		Initial State
INT_URX	[0]	0=Masked	1=Service available	0
INT_UTX	[1]	0=Masked	1=Service available	0
INT_UERR	[2]	0=Masked	1=Service available	0
INT_TOF0	[3]	0=Masked	1=Service available	0
INT_TMC0	[4]	0=Masked	1=Service available	0
INT_TOF1	[5]	0=Masked	1=Service available	0
INT_TMC1	[6]	0=Masked	1=Service available	0
INT_TOF2	[7]	0=Masked	1=Service available	0
INT_TMC2	[8]	0=Masked	1=Service available	0
INT_TOF3	[9]	0=Masked	1=Service available	0
INT_TMC3	[10]	0=Masked	1=Service available	0
INT_TOF4	[11]	0=Masked	1=Service available	0
INT_TMC4	[12]	0=Masked	1=Service available	0
INT_TOF5	[13]	0=Masked	1=Service available	0
INT_TMC5	[14]	0=Masked	1=Service available	0
INT_BT	[15]	0=Masked	1=Service available	0
EINT0	[16]	0=Masked	1=Service available	0
EINT1	[17]	0=Masked	1=Service available	0
EINT2	[18]	0=Masked	1=Service available	0
INT_PWMOF	[19]	0=Masked	1=Service available	0
INT_PWMMC	[20]	0=Masked	1=Service available	0

INTERRUPT VECTOR BASE ADDRESS

The S3F443FX can support two interrupt vector modes. One is a normal interrupt mode and the other is the vectored interrupt mode.

— Normal Interrupt mode

In normal interrupt mode it has two base addresses to serve IRQ(address: 0x18) and FIQ(address: 0x1C). In other words, as soon as CPU recognizes the interrupt request, there will be a branch to fixed address 0x18 or 0x1C. Because the ARM can support just two interrupt modes of FIQ and IRQ, after jumping to the destined base address by H/W the user program tries to identify the interrupt source matched to the requested interrupt. And then CPU makes PC(program counter) jump to corresponding ISR(interrupt service routine). The process of searching for the corresponding ISR(interrupt service routine) should be performed by S/W, which can be flexible but requires interrupt latency.

— Vectored Interrupt mode

To reduce the interrupt latency, the case of interrupt latency is critical in the system, s3f443fx can support the concept of interrupt vector base address. Without time latency to branch the real start address of respective interrupt source by going through IRQ or FIQ base address, it will directly go to its base address matching to the requested interrupt source. The below shows the fixed start address of corresponding requested interrupt when it has interrupt vector mode, not normal interrupt mode. When interrupt vector mode is enabled, the most high priority interrupt among the requested interrupt sources is serviced by CPU. The CPU will branch into its vector address as shown below, directly. Address is calculated with being based on IRQ or FIQ memory address. Because ARM core is recognized all Interrupt Service Routine(ISR) address based on 0x18 or 0x1C. So direct ISR address for user to make the H/W interrupt vector table has to be concerned. (INT_UTX is the second interrupt source)

B	HandlerUTXD		(X)
B	HandlerUTXD	+ (INT_MODE_ADD+4*1)	(O)

<Example> Vectored Interrupt code

```

AREA  Init,CODE,READONLY

ENTRY

B ResetHandler  ;for debug

B HandlerUndef  ;handlerUndef

B HandlerSWI    ;SWI interrupt handler

b HandlerPabort ;handlerPAbort

b HandlerDabort ;handlerDAbort

b .            ;handlerReserved

b IsrIRQ

b IsrFIQ

```

VECTOR_BRANCH**;H/W interrupt vector table****;INT_MODE_ADD is defined any proper address by user****;Assume INT_MODE_ADD's value to be 0x20.**

```

b HandlerURXD  + (INT_MODE_ADD+4*0)
b HandlerUTXD  + (INT_MODE_ADD+4*1)
b HandlerUERR  + (INT_MODE_ADD+4*2)
b HandlerT0OVF + (INT_MODE_ADD+4*3)
b HandlerT0MC  + (INT_MODE_ADD+4*4)
b HandlerT1OVF + (INT_MODE_ADD+4*5)
b HandlerT1MC  + (INT_MODE_ADD+4*6)
b HandlerT2OVF + (INT_MODE_ADD+4*7)
b HandlerT2MC  + (INT_MODE_ADD+4*8)
b HandlerT3OVF + (INT_MODE_ADD+4*9)
b HandlerT3MC  + (INT_MODE_ADD+4*10)

```

Branch command to be executing	
Sources	Address
INT_URX	0x20
INT_UTX	0x24
INT_UERR	0x28
INT_TOF0	0x2c
INT_TMC0	0x30
INT_TOF1	0x34
INT_TMC1	0x38
INT_TOF2	0x3c
INT_TMC2	0x40
INT_TOF3	0x44
INT_TMC3	0x48
INT_TOF4	0x4c
INT_TMC4	0x50
INT_TOF5	0x54
INT_TMC5	0x58
INT_BT	0x5c
EINT0	0x60
EINT1	0x64
EINT2	0x68
INT_PWMOF	0x6c
INT_PWMMC	0x70

INTERRUPT PRIORITY REGISTER

The interrupt priority registers (INTPRI_n) have information about which kind of interrupt sources are assigned to the pre-defined interrupt priority fields. For example, If the PRIORITY 3 has 16 (the number of EINT0 is 16), the EINT0 interrupt source will have priority level 3. The highest priority value is priority level 0, and the lowest value is priority level 20. 3-bit left side of PRIORITY0 field as called EN has the meaning of determination on vector interrupt mode or normal interrupt mode as explained in previous page. If 3-bit is 0, it means the normal interrupt mode for the corresponding interrupt request. Otherwise, it means the interrupt vector mode.

Register	Offset Address	R/W	Description	Reset Value
INTPRI0	0xc00c	R/W	Interrupt priority 0 register	0302 0100h
INTPRI1	0xc010	R/W	Interrupt priority 1 register	0706 0504h
INTPRI2	0xc014	R/W	Interrupt priority 2 register	0b0a 0908h
INTPRI3	0xc018	R/W	Interrupt priority 3 register	0f0e 0d0ch
INTPRI4	0xc01c	R/W	Interrupt priority 4 register	1312 1110h
INTPRI5	0xc020	R/W	Interrupt priority 5 register	1716 1514h
INTPRI6	0xc024	R/W	Reserved to 0x1b1a1918	1b1a 1918h
INTPRI7	0xc028	R/W	Reserved to 0x1f1e1d1c	1f1e 1d1ch

Register		[28:24]		[20:16]		[12:8]		[4:0]
INTPRI0	EN	PRIORITY3	X	PRIORITY2	X	PRIORITY1	X	PRIORITY0
INTPRI1	X	PRIORITY7	X	PRIORITY6	X	PRIORITY5	X	PRIORITY4
INTPRI2	X	PRIORITY11	X	PRIORITY10	X	PRIORITY9	X	PRIORITY8
INTPRI3	X	PRIORITY15	X	PRIORITY14	X	PRIORITY13	X	PRIORITY12
INTPRI4	X	PRIORITY19	X	PRIORITY18	X	PRIORITY17	X	PRIORITY16
INTPRI5	X	X	X	X	X	X	X	PRIORITY20

INTPRI0	Bit	Description	Initial State
EN	[31:29]	000 = Disable interrupt priority other = Enable interrupt priority	000
PRIORITY N	5-bit	The priority number for interrupt request source N.	
X	3-bit	Do not care field.	

NOTES:

- To use the programmable priority, set EN to 000b, then the priority should be determined by SW.
- The PRIORITY_n determines the priority of the corresponding interrupt source. For an instance, if you want to set the priority of EINT0 highest one, you have to write down 16(interrupt number of EINT0) on PRIORITY0. On the contrary you want to set the priority of EINT0 lowest, you should write 16 on PRIORITY20. With the above way, you can control the priority level of a certain interrupt source from 0 to 20
- The highest priority is PRIORITY0, and the lowest priority is PRIORITY20.

NOTES

9

SYSTEM MANAGER

OVERVIEW

The S3F443FX System Manager has the following functions:

- Supports the big-endian mode. The internal system and the external memory are fixed as big-endian mode.
- Memory controller for external memory/IO as well as internal memory.
- Programmable Bank start and Bank end addresses.
- Programmable access time for memory/IO access.

SYSTEM MANAGER REGISTERS

The S3F443FX has the SFRs, Special Function Registers, to keep the system control information of system manager as well as the configuration on peripherals. Among SFRs, there are SMRs (System Manager Register files), to configure the external memory maps such SRAM, ROM and etc.

By utilizing the SMR, the user can specify the memory type, access cycles, required control signal timings, and memory bank location. The SMR provides (or accepts) the control signals and addresses which are needed to access external devices during normal system operation. Three registers control the memory banks

The S3F443FX provides up to 32Mbytes of address space and each bank provides up to 256Kbytes of memory space because each bank can have 18 address pins.

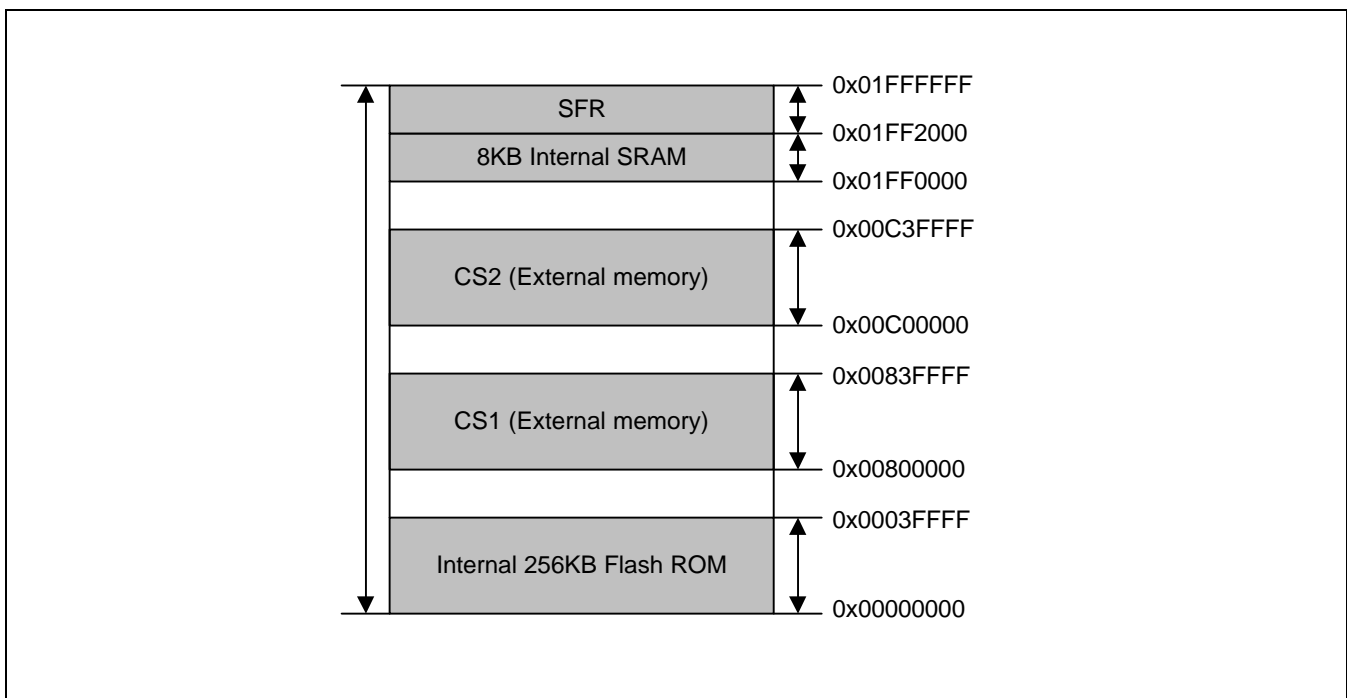

Figure 9-1. S3F443FX Default Memory Map of the Normal Mode (In ROM Mode)

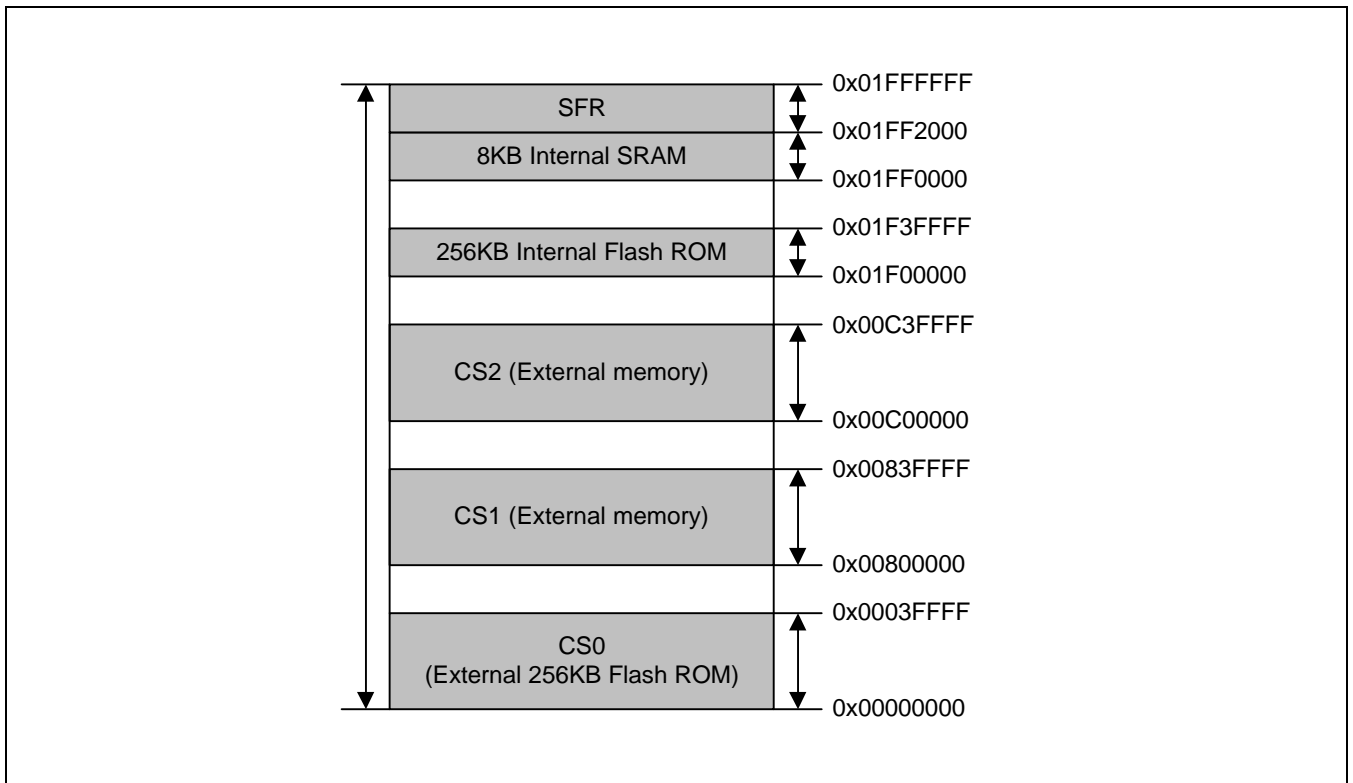

Figure 9-2. S3F443FX Default Memory Map of External ROM Mode

The S3F443FX provides 32-MByte memory space and an internal 25-bit system address bus. You can use any of the bank area addresses from 000_0000h to 1FF_FFFFh in 1M byte address steps. Each bank can be located anywhere in the 32-MByte address space.

However, the user should allocate the SFRs to the upper 64-kbyte address areas, 1FF0000h -1FFFFFFh.

The configurable memory allocation in the S3F443FX is very effective in meeting user requirement. By manipulating the SMRs, the user can easily allocate the memory area anywhere user desires and use the consecutively connected memory space without changing the H/W.

For example, if the user wants to change the size of memory space from 1Mbytes to 2 Mbytes, the user can expand the memory space by changing the next pointer of the bank and bank end address.

NOTE

Although the size of each bank may be more than 1M bytes, the physical bank size is max 256Kbytes because the number of the address pins is 18 in total.

SYSTEM REGISTER ADDRESS CONFIGURATION REGISTER (SYSCFG)

The SMRs (System Manager Registers) have the SYSCFG (System Register Address Configuration Register), which determines the start address (base point) of SFR (Special Function Register) files. The SYSCFG has the start address of SFR. Because the reset value of SYSCFG is 1FF1h, the SYSCFG is mapped to the virtual address 01FF 1000h.

Register	Offset Address	R/W	Description	Reset Value
SYSCFG	0x3000	R/W	Special function register to determine the start address	0x1FF1

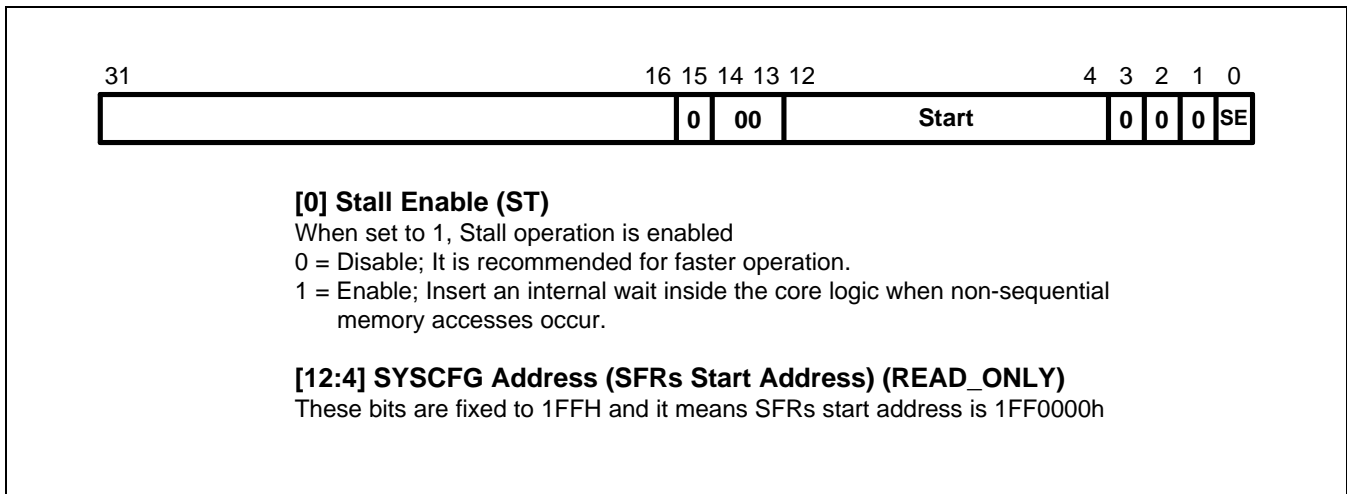

Figure 9-3. System Register Address Configuration Register (SYSCFG)

EXTERNAL MEMORY CONTROL SPECIAL REGISTERS

MEMORY CONTROL REGISTER 0, 1, 2

Register	Offset Address	R/W	Description	Reset Value
MEMCON0	0x4000	R/W	Memory control register 0 (nCS0)	0800 3000h
MEMCON1	0x4004	R/W	Memory control register 1 (nCS1)	0c08 3000h
MEMCON2	0x4008	R/W	Memory control register 2 (nCS2)	100c 3000h

[1:0]	Reserved	Reserved to 00b		
[4:2]	Tcos	000 = 0 cycles 011 = 3 cycles 110 = 6 cycles	001 = 1 cycles 100 = 4 cycles 111 = 7 cycles	010 = 2 cycles 101 = 5 cycles
[7:5]	Tacs	000 = 0 cycles 011 = 3 cycles 110 = 6 cycles	001 = 1 cycles 100 = 4 cycles 111 = 7 cycles	010 = 2 cycles 101 = 5 cycles
[10:8]	Tcoh	000 = 0 cycles 011 = 3 cycles 110 = 6 cycles	001 = 1 cycles 100 = 4 cycles 111 = 7 cycles	010 = 2 cycles 101 = 5 cycles
[13:11]	Tacc	Memory access time (Tacc) 000 = Disable bank 001 = 2 cycles 010 = 3 cycles 011 = 4 cycles 100 = 5 cycles 101 = 6 cycles 110 = 7 cycles 111 = 8 cycles If nWAIT is used, Tacc ≥ 3		
[15:14]	Reserved	Reserved to 00b		
[23:16]	Base Address(BA)	Indicates Bank start address. User can configure bank size by 1MB unit. If bank start address is 0x0100000, the base address(BA) field value of this bank should be 0x01. The available range is 0-0x1e.		
[31:24]	End Address(EA)	Indicates Bank end address. If the end address of the bank is 0x0f3fff, the end address (EA) field value of this bank should be 0x10((0f3ffff>>20) +1). The available range is 0x1-0x1f		

NOTES:

- nCS0 can be used for another external device if the In-ROM mode is selected by MD[1:0]=00b. If the nCS0 area is overlapped with the internal flash memory, the internal flash ROM will be read by CPU.
- nCS0 will be used for boot ROM if the external ROM mode is selected by MD[1:0]=01b.

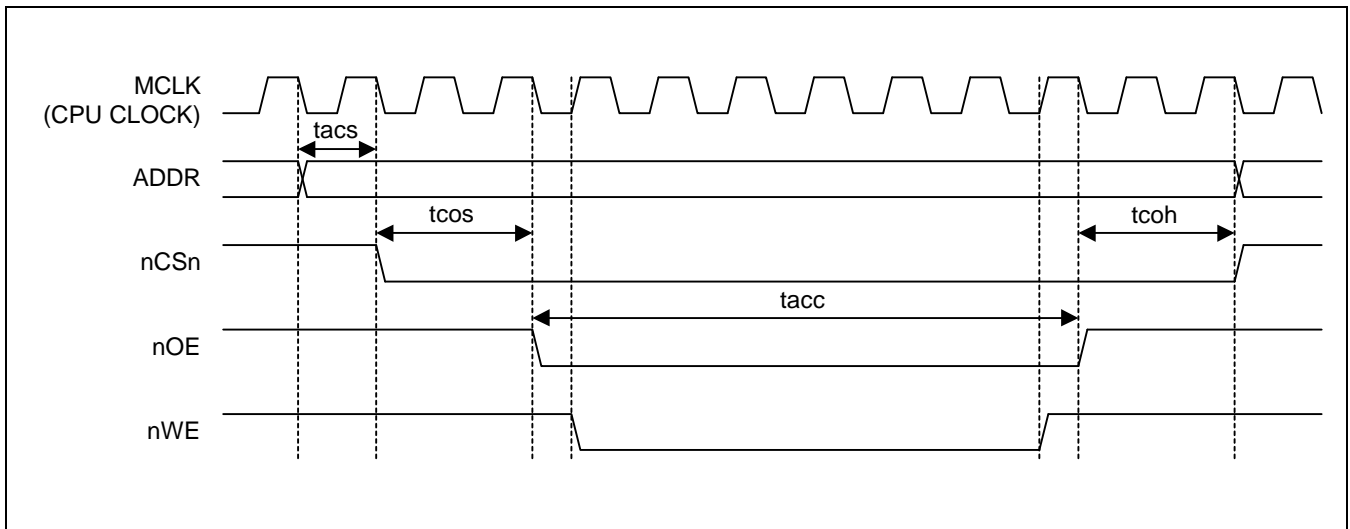

Figure 9-4. An Example of S3F443FX nCSn Timing Diagram

10 INTERNAL FLASH ROM

OVERVIEW

The S3F443FX has an on-chip flash ROM, internally. For writing the data in flash ROM, the user can access the flash ROM by a program or the external serial interface. Because of the full feature of NOR flash memory, user can program the data in any address and in any time. The size of embedded flash memory in S3F443FX is 256K-byte and it has the following features:

- Tool program mode (Apply VDD 3.3V externally and the dedicated serial interface)
- User program mode (Use the internal high voltage generator)
- Protection mode: Hardware protection, Read protection

The S3F443FX has 6 pins used for Flash ROM writer to read/write/erase the flash memory ($V_{DD(1.8V)}$, $V_{DD(3.3V)}$, $V_{SS(3.3V)}$, $V_{SS(1.8V)}$, RESET, VPP, SDAT, SCLK), which is the programming by tool program mode. These six pins are multiplexed with other functional pins. When the S3F443FX is in $V_{PP} (MD1) = V_{DD} - 3.3V$ (internal flash ROM test mode) & RESET (nRESET= L), these six pins can be used for flash programming in tool program mode.

NOTE

Tool means an equipment such as a ROM writer. One of the tool which is used to program/erase the internal flash (s3f443fx) is SPW2+.

PROGRAMMING MODES

The S3F443FX flash memory control block supports two kinds of program mode:

- Tool Program Mode
- User Program Mode

Flash ROM Configuration

The 256KB Flash ROM consists of 512 sectors. Each sector consists of 512 bytes. So, the total size of flash ROM is 512 x 512 bytes (256KB). User can erase the flash memory a sector unit at a time and write the data into the flash memory word (4 bytes) unit at a time.

Additionally, there is the option sector, which is different from 256KB memory cell. This optional sector consists of smart option bits and protection option bits. These bits control the protection features. These bits can be read only by the FSOREAD/FPOREAD register.

The smart option bits are mapped to the address of 0xe38 (4bytes). The protection option bits are also mapped to the address of 0xe3c (4 bytes).

Address Alignment

To set an address value in FMADDR register, abide by the following rules.

- Sector Erase : When erasing a sector, the low 9-bit address (FMADDR[8:0]) should be 00000000b because the size of a sector is 512 bytes.
- Program : When programming the Flash ROM, the lower 2-bit (FMADDR[1:0]) should be 00b because data should be written to the Flash ROM by a word unit (4 bytes).

NOTE

In the tool program mode, the low 2-bit address also should be 00b.

User Program Mode

User program mode is for erasing and writing internal flash ROM not by a tool writer but by User Program. To enhance this, S3F443FX has the internal high voltage generator, which is replacing Vpp pin of supplying high voltage into internal flash cells through tools, MD1 pins may be tied to V_{SS} or V_{DD} (in only MDS mode). More details are as follows.

The Program Procedure in the User Program Mode

In order to enable User Program Mode, first set FMUCON.3 (Normal Sector Program Enable) and make a decision of using or not CPU hold function with FAMCON.7 (CPU hold bit) set. For an example, there is about 30us time required for one word data (32-bit) to be written to specific address flash cell. During that time, there are two kinds of ways to recognize that the operation for erasing and writing of Internal flash ROM is finished. One is CPU hold function that stops CPU not to work until all process is finished, another one is that while CPU is running, program code continuously is being executed to check Operation start/stop bit (FMUCON.7 is cleared). Usually CPU hold function is recommended. Especially CPU hold function must be used, when current running code is located on Internal flash ROM. Because that during programming internal flash cell the high voltage that goes around internal flash ROM will affect bad influence on fetching code from internal flash ROM. However after that, write the data to be written on the data register (FMDATA) and the address into the address register (FMADDR) respectively. As a next step, the user should write the values (0x5a, 0xa5, 0x5a, 0xa5 in sequence) on key registers 0/1/2/3 (FMKEY0-3). Finally, by set appropriate configuration on flash memory control register(FMUCON), one word data (32-bit) can be written into flash memory at the location of the specified address. After the completion of the write operation, all FMKEY registers and the start bit in FMUCON will be cleared. To perform the next writing operation, FMKEY0-3 registers and FMUCON register should be written again as before.

Sector erase procedure is the same as program procedure except setting the Flash memory data register (FMDATA).

Tool Program Mode

The 6 pins are connected to a tool board and programmed by Serial OTP Tool (SPW). V_{DD} 3.3V should be applied to the MD1 (V_{PP}) pin. The other modules except the internal flash ROM will be in reset state.

This mode does not support the sector erase. Instead the chip erase is supported. Two protection modes(hard lock/read protection) can be enabled in this mode.

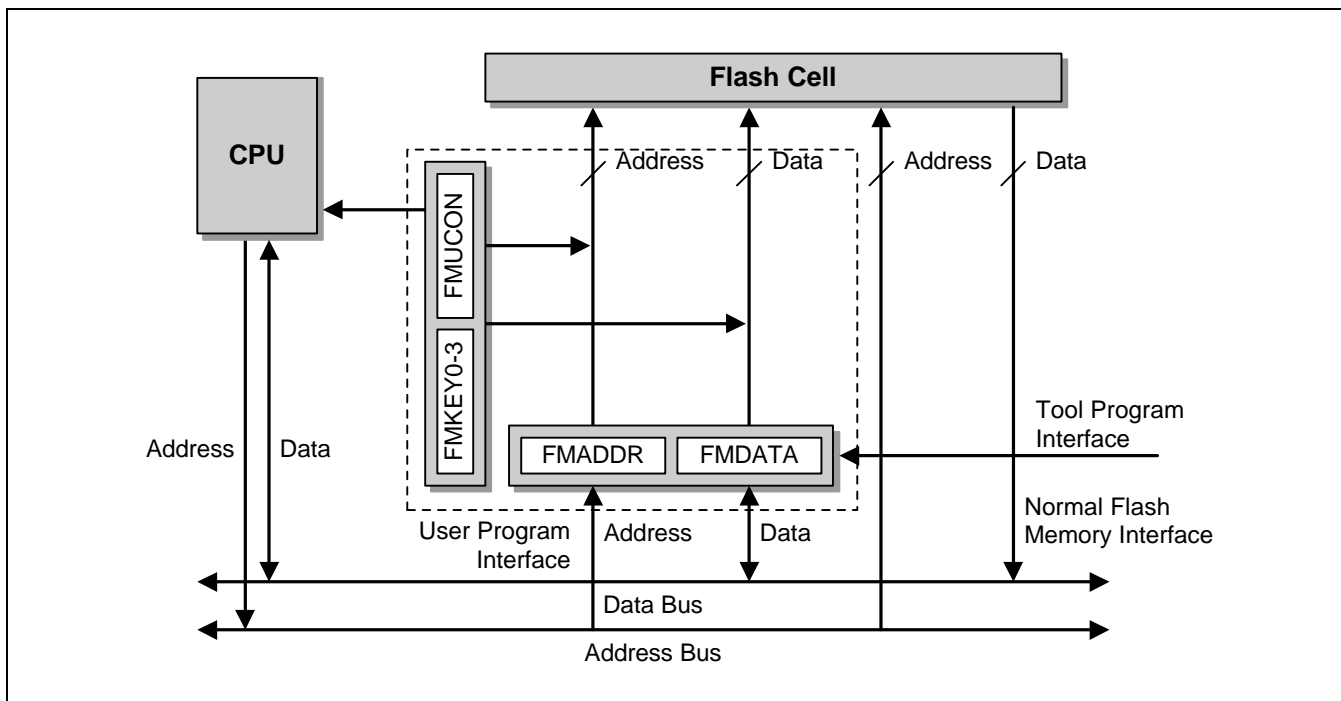

Figure 10-1. Flash Memory Read/Write Block Diagram

FLASH MEMORY SPECIAL REGISTERS

FLASH MEMORY KEY REGISTERS

To program data into the flash memory by the user programming mode, 4-key registers with 0x5a,0xa5,0x5a and 0xa5 are required to prevent flash data from being destroyed under undesired situations.

Register	Offset	R/W	Description	Access	Reset Value
FMKEY0	0x3010	W	Flash program / erase Key register0	B	00h
FMKEY1	0x3011	W	Flash program / erase Key register1	B	00h
FMKEY2	0x3012	W	Flash program / erase Key register2	B	00h
FMKEY3	0x3013	W	Flash program / erase Key register3	B	00h

NOTE: The FMKEYn register will be cleared automatically just after the completion of erase/program.

FLASH MEMORY ADDRESS REGISTER

In spite of address configuration In-ROM mode (Internal Flash ROM area: 0000 0000h–0003 FFFFh) or External ROM (ROM-less) mode (Internal Flash ROM area: 01F0 0000h–01F3 FFFFh), It is fixed for flash writing and erasing address as like from 0000 0000h to 0003 FFFFh. therefore although External ROM mode is configured, the address written to FMADDR is from 0000 0000h to 0003 FFFFh.

Register	Offset	R/W	Description	Access	Reset Value
FMADDR	0x3014	R/W	Flash program / sector erase address register	W	0000 0000h

NOTE: To program the Option Sector area, set FMADDR to 0x0e38 (smart option) or 0xe3c (protection option) and FMDATA by the appropriate value and start the write operation.

FLASH MEMORY DATA REGISTER

Register	Offset	R/W	Description	Access	Reset Value
FMDATA	0x3018	R/W	Flash program data register	W	0000 0000h

FLASH MEMORY USER PROGRAMMING CONTROL REGISTER

The FMUCON can determine the program/erase operation. In user programming mode, the S3F443FX can support sector erase; flash memory should be programmed by a word unit. However, It requires a consideration in order to erase option sector area related to protection mode. When Flash erase to be used protection option is being executed, at the same time all normal sectors are being erased as it called "chip erase". In a consequence Internal flash ROM is to be initialized data status. There are 4 enable bits in FMUCON, in which only one has to be set enabled in one time. If more than 2 bits are concurrently set enabled, it will produce configuration error. In this case, clear the error register and start the operation again.

Register	Offset	R/W	Description	Access	Reset Value
FMUCON	0x301f	R/W	Flash memory program/sector erase control register	B	00h

[0]	Chip Erase Enable(CERS) (by using protection option)	0 = Disable	1 = Enable
[1]	Normal Sector Erase Enable (NSERS)	0 = Disable	1 = Enable
[2]	Option (smart option) Sector Program Enable(OSPGM)	0 = Disable	1 = Enable
[3]	Normal Sector Program Enable (NSPGM)	0 = Disable	1 = Enable
[6:4]	Not used	Not used	
[7]	Operation Start/Stop	0 = Stop	1 = Start

This bit will be cleared automatically just after the corresponding operation is completed.

The FMACON can control the cycle of read access for flash memory. This register setting is effective for reading flash memory.

Register	Offset	R/W	Description	Access	Reset Value
FMACON	0x3027	R/W	Flash memory access control register	B	03h

[1:0]	Flash Memory Access Cycles	11b= 3 cycles	10b = 2 cycle
		01b= 1 cycles	00b = Not used
		The internal Flash ROM access time is 25ns. So, the access cycles will be configured as follows.	
		@ 40Mhz: 1 cycle	
		@ 80Mhz: 2 cycles	
[6:2]	Reserved		
[7]	CPU hold during Flash operation	0 = CPU working during Flash programming/erasing In this case, the flash programming/erasing code should not be on the internal flash ROM. The completion of an operation is checked using FMUCON register. The advantage is that CPU can perform other tasks until the completion of an operation. 1 = CPU hold during Flash programming/erasing	

FLASH MEMORY SMART OPTION BITS READ REGISTER

Be cautious of reading the Smart option / Protection option bits. It is possible only through FSOREAD / FPOREAD registers because the bits of Smart option / Protection option cannot be read like normal cell.

Register	Offset Address	R/W	Description	Initial Value (at Fabrication)
FSOREAD	0x3028	R	Smart Option bits read register	MSB xxxx_xxxx [31:24] xxxx_xxxx 1111_1111 LSB 1111_1111b [7:0]

FLASH MEMORY PROTECTION OPTION BITS READ REGISTER

Register	Offset Address	R/W	Description	Initial Value (at Fabrication)
FPOREAD	0x302C	R	Protection Option bits read register	MSB xxxx_1xxx xxxx_xx1x xxxx_xxx1 LSB xxxx_xxxx

NOTE

If any bit of FMERR register is set, the user must clear the FMERR register and write (erase) the flash memory again at first.

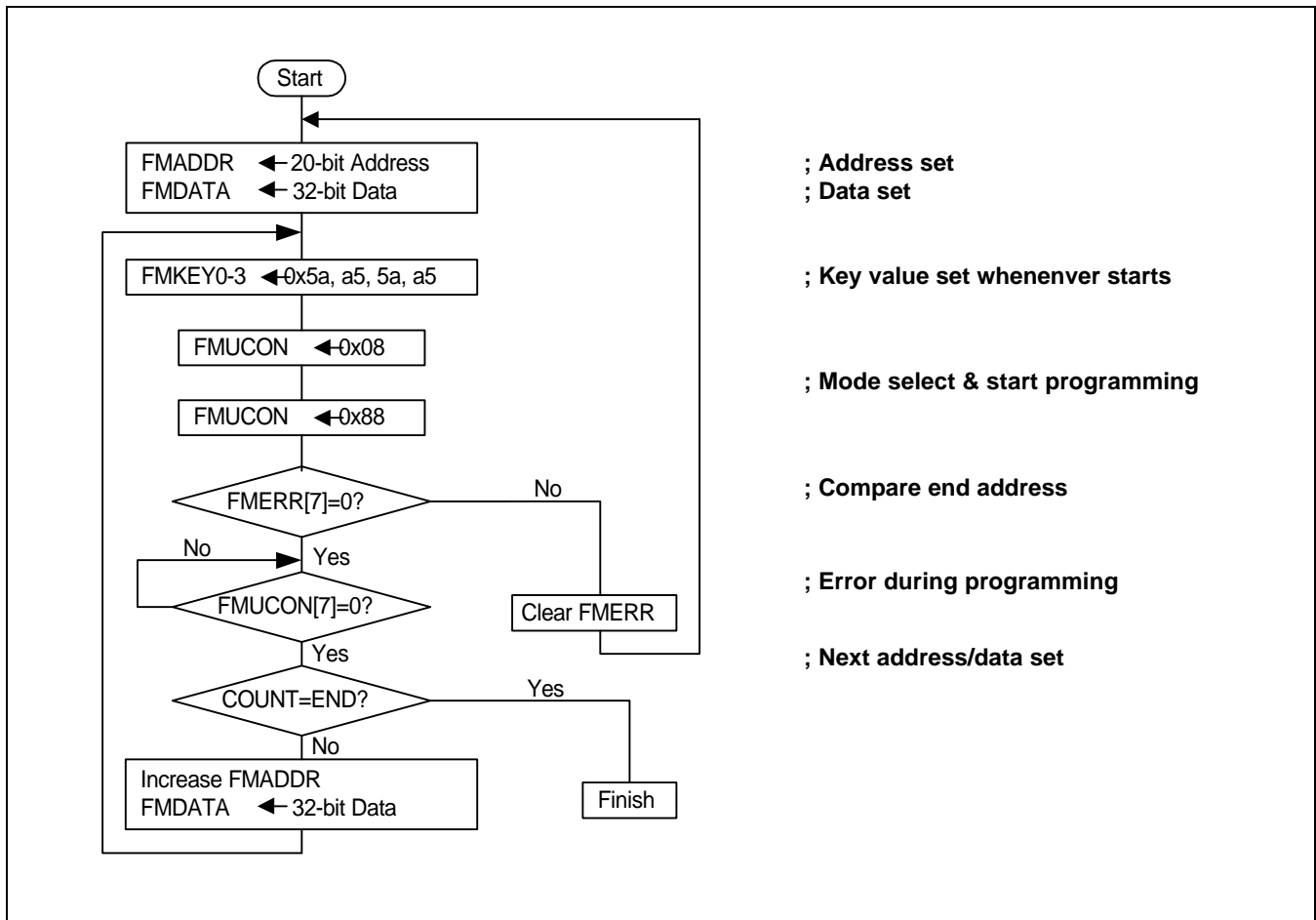

Figure 10-2. Normal Sector Program Flowchart in a User Program Mode

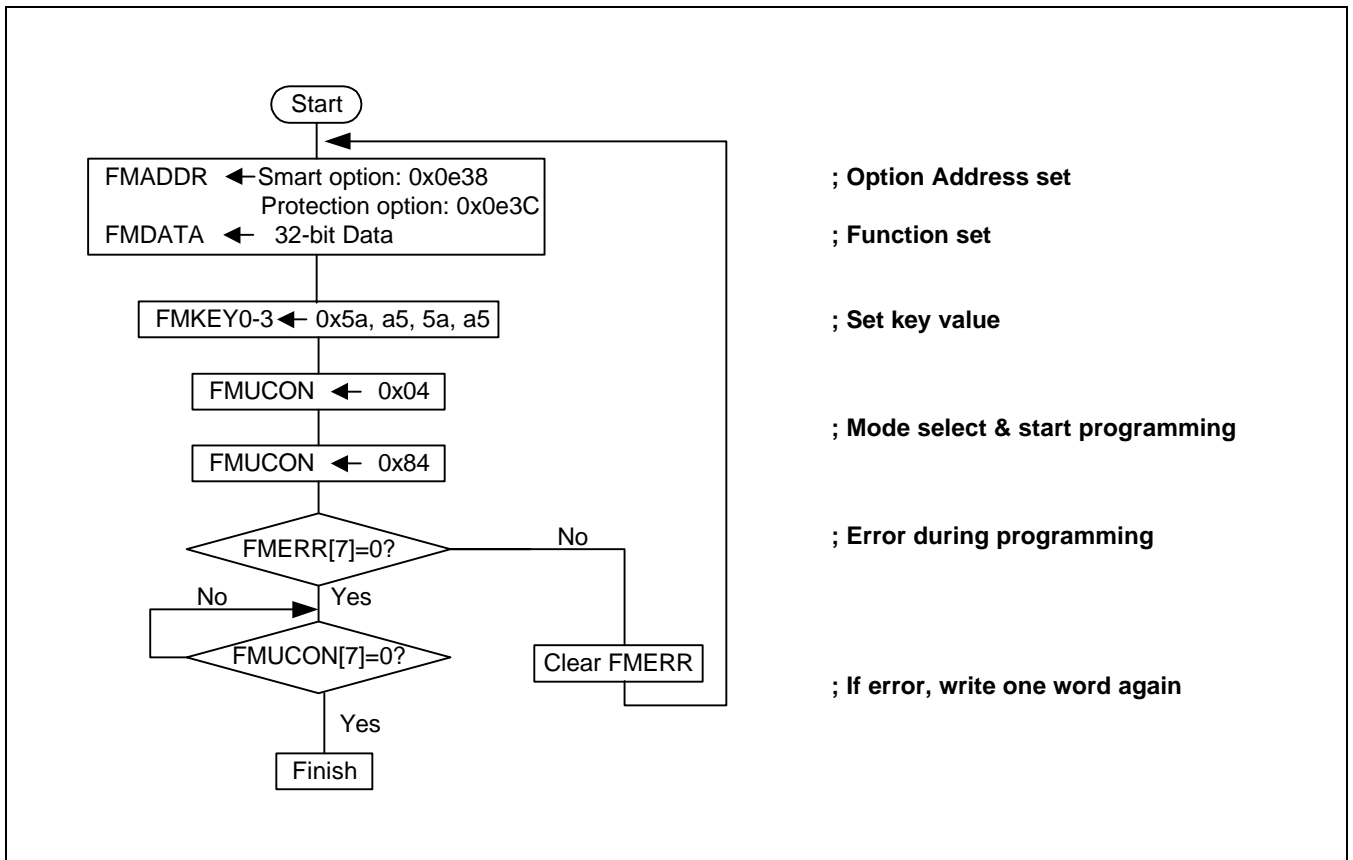

Figure 10-3. Option Sector Program Flowchart in a User Program Mode

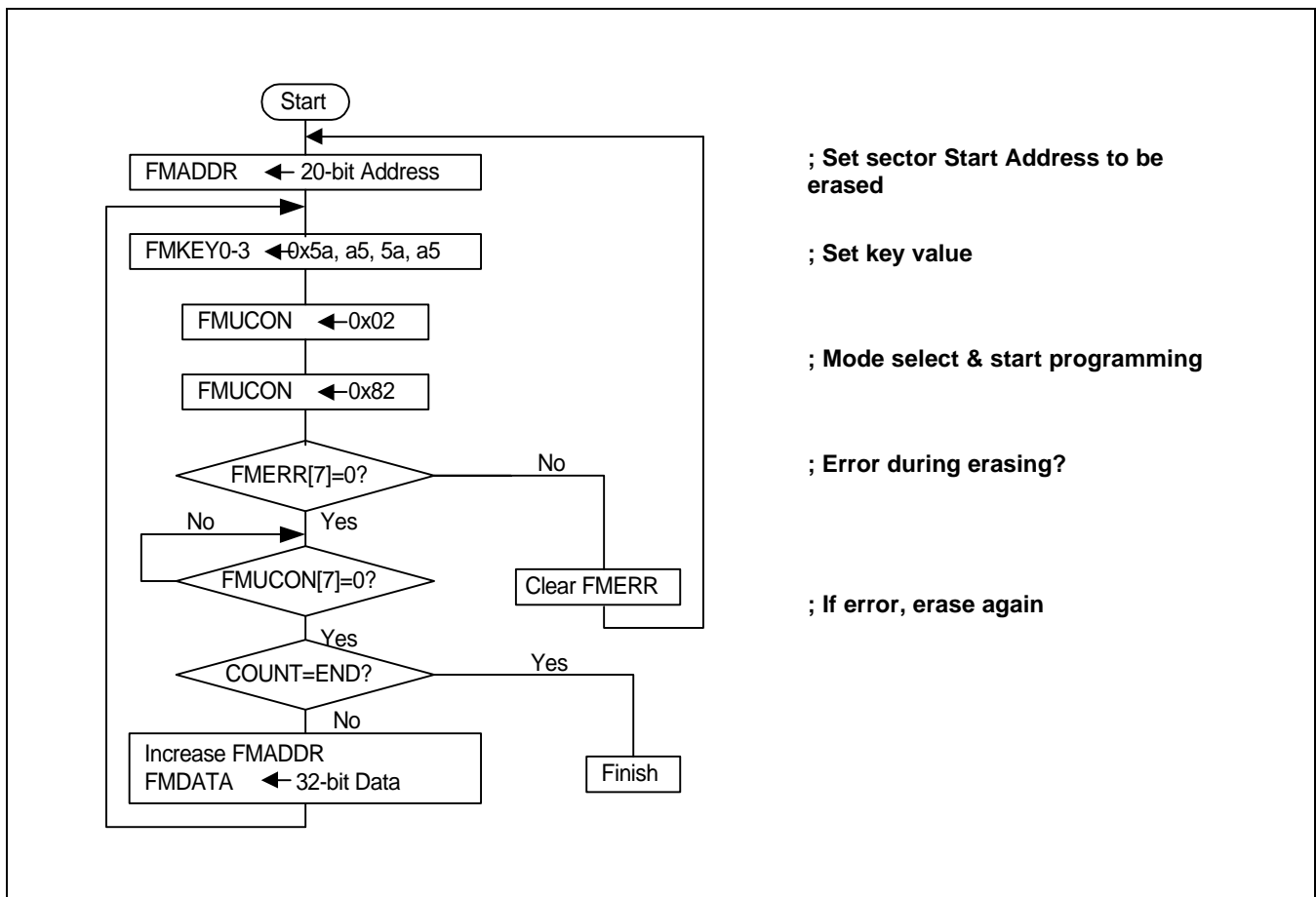

Figure 10-4. Normal Sector Erase Flowchart

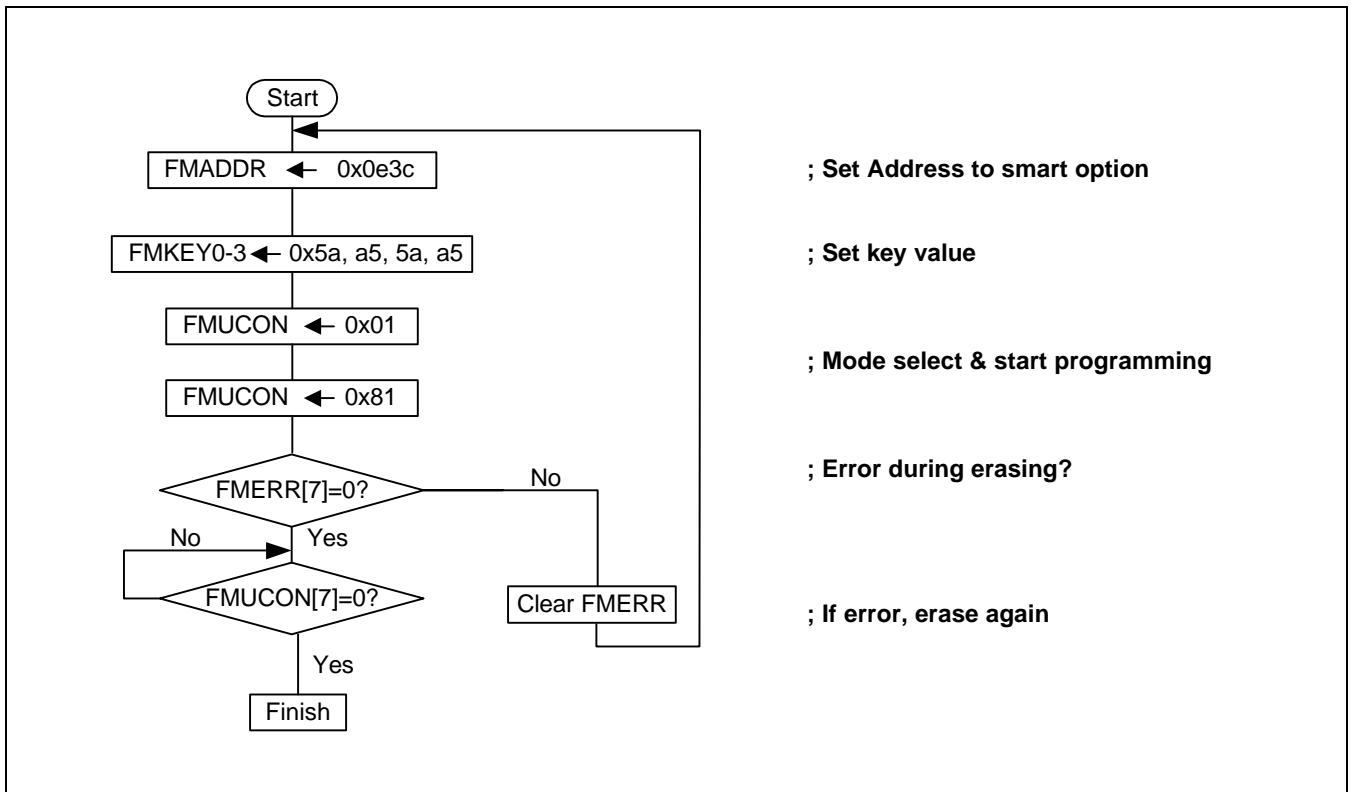

Figure 10-5. Full Chip Erase Flowchart (In User Program Mode)

DATA PROTECTION

S3F443FX provides two kinds of protection mechanism.

- Hardware protection
- Read protection

These protection modes can be enabled by the configuration in the option sector. User can select it in the tool program mode or the protection option bit/smart option bit in a user program mode.

The protection option bits (0x0e3c) can be enabled/disabled in terms of hardware protection and read protection. The smart option bits (0x0e38) can adjust the area of hardware protection.

PROTECTION OPTION

Protection Bit table

FMADDR value	FMDATA bit	Description	Initial Value (at Fabrication)
0x0e3c	bit[7:0]	Not used	undefined
	bit[8]	1: fixed value ,do not change	1
	bit[16:9]	Not used	undefined
	bit [17]	0: Enable the hardware protection 1: Disable the hardware protection	1
	bit[26:18]	Not used	undefined
	bit [27]	0: Enable the read protection 1: Disable the read protection	1
	bit[31:28]	Not used	undefined

Read Protection bit 27

In order to prevent Internal Flash data from being read by tools, S3F443FX supports Read Projection which disables JTAG port and hampers being read serially in the tool program equipments. Hence trying to read or verify internal flash data in the tool program mode will result in all zero read-out. However if Hardware Protection is not activated, user could set Read Protection in user program mode and tool program mode. In terms of user program mode, the procedure of setting Read Protection is as follows, first set FMUCON.2(Option Sector Program Enable Bit), decide whether to set FMACON.7, write 0x0e3c to the FMADDR, 0x00ffff to FMDATA and then follow the flowchart of Figure 10-3. By the tool this protection is set possible. Please refer to the manual of serial program writer tool provided by the manufacturer. Meanwhile if the user intends to release protection, make chip erase chip erase **the option sector erase** which is described in detail at Fig10-5. But it should be noted that if Hardware Protection is not activated, Chip erase using Protection Option **Option Sector Erase** can release all kinds of protections and erase all the data in the internal flash ROM as like chip erase supported by tool program mode.

Hardware Protection (hard lock) bit 17

If this function is enabled, the user cannot write or erase the data in a flash memory area and option sector area. Hardware Protection is available in tool program mode as well as in user program mode. This protection can be released **by the chip** erase execution (in the tool program mode or user program mode). Refer to smart option about hard lock protection of blocks.

User could set Hardware Protection in user program mode and tool program mode. In terms of user program mode, the procedure of setting Hardware Protection is that set FMUCON.2 (Option Sector Program Enable Bit), decide whether to set FMACON.7, write 0x0e3c to the FMADDR, 0xff00fff to FMDATA and then follow the flowchart of Figure 10-3, Whereas in tool mode the manufacturer of serial tool writer could support Hardware Protection. Please refer to the manual of serial program writer tool provided by the manufacturer.

SMART OPTION FOR H/W PROTECTION

In the Hardware protection function, the certain block area can be free of protection according to corresponding smart option bits set, which are allocated in the address of smart option (0x0e38) for this function.

To enable the protection function on a certain block,

- Configure the smart option bits,
- Configure the H/W protection option bits (0x0e3c).

If the smart option bits are not configured (as default set), full 256K bytes flash memory will be protected.

FMADDR Value	FMDATA Bit	Operation after Program	Erased Value (initial)
0x0e38	Bit [0]	0: H/W protection is disabled at the area of 0K–16K	1
	Bit [1]	0: H/W protection is disabled at the area of 16K–32K	1
	Bit [2]	0: H/W protection is disabled at the area of 32K–48K	1
	Bit [3]	0: H/W protection is disabled at the area of 48K–64K	1
	Bit [4]	0: H/W protection is disabled at the area of 64K–80K	1
	Bit [5]	0: H/W protection is disabled at the area of 80K–96K	1
	Bit [6]	0: H/W protection is disabled at the area of 96K–112K	1
	Bit [7]	0: H/W protection is disabled at the area of 112K–128K	1
	Bit [8]	0: H/W protection is disabled at the area of 128K–144K	1
	Bit [9]	0: H/W protection is disabled at the area of 144K–160K	1
	Bit [10]	0: H/W protection is disabled at the area of 160K–176K	1
	Bit [11]	0: H/W protection is disabled at the area of 176K–192K	1
	Bit [12]	0: H/W protection is disabled at the area of 192K–208K	1
	Bit [13]	0: H/W protection is disabled at the area of 208K–224K	1
	Bit [14]	0: H/W protection is disabled at the area of 224K–240K	1
	Bit [15]	0: H/W protection is disabled at the area of 240K–256K	1

NOTE: The flash programming tips is as follows; Characteristic of flash memory cell, a bit can be changed from 1 to 0 but not the vice versa by writing data into flash memory cell. If users do not want to change the certain cell, the user only needs to write the bit as 1.

FLASH MEMORY MAP

The S3F443FX can support two operating modes, the Normal operating mode(In-ROM mode) and the External ROM(ROM-less) mode.

In the normal operating mode, the program as well as boot program should exist in the internal flash memory. In the External ROM(ROM-less) mode, the internal flash memory will be mapped to the other addresses as shown in the below figure.

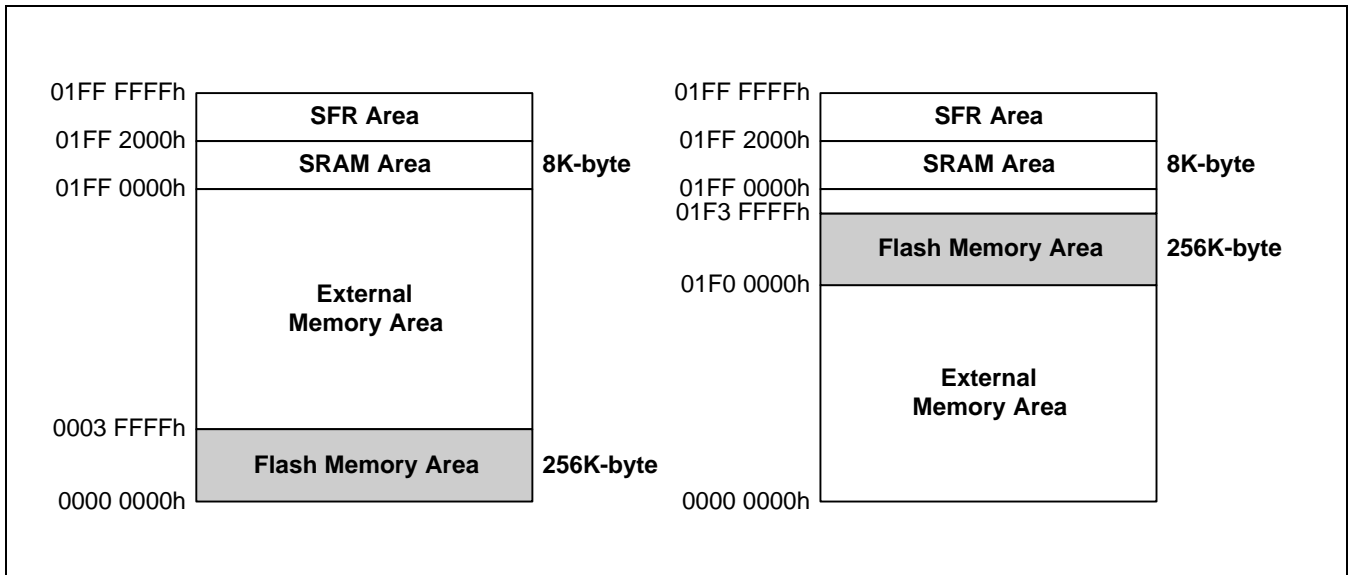

Figure 10-6. Flash Memory Map according to Operating Mode

TOOL PROGRAM MODE

The tool program mode is the flash memory program mode, which uses an equipment such as a ROM writer

Table 10-1. The Pins Used to Read/Write/Erase the Flash ROM in Tool Program Mode

Pin Name	Function Name	Pin No.	I/O	Function
RXD/GPIO15	SDAT	9	I/O	Serial DATA pin. (Output when reading, Input when writing.) Input & push-pull output port can be assigned
TXD/GPIO14	SCLK	10	I	Serial CLOCK, input only (Write speed: Max 1 MHz, Read speed : Max 5 MHz)
MD1	VPP (VDD3.3V)	14	I	When this pin is supplied with Vdd (3.3V), Tool flash writing mode enters. Don't link it with 12.5 volt of VPP generated from tools. The internal Voltage pumping circuit is built in S3F443FX in replace of high voltage outside, which can be possible to make the internal circuit broken.
NRESET	RESET	13	I	Chip Initialization
VDD(3.3V)	VDD(3.3V)	4,30	I	3.3Volt supplied port
VSS(3.3V)	VDD(3.3V)	3,29	I	3.3Volt ground pin
VDD(1.8V)	VDD(1.8V)	12,44,60	I	1.8Volt supplied port
VSS(1.8V)	VSS(1.8V)	11,43,59	I	1.8Volt ground pin

11

8-BIT PWM

OVERVIEW

The S3F443FX has an eight bit PWM (Pulse Width Modulation) counter, the clock signal supplied to 8 bit PWM is driven from external clock divided by 1 or 2 and when the counter is stop , counting value will be retained until the counter is restarted and running. If the counting value exceeds 256 or 127, it will be set to zero and resumed.

- 8 BIT resolution PWM (Pulse Width Modulation)
- Clock source is driven from external clock (EXTCLK)
- PWM_out shares PIN20 with A14/GPIO10
- Counter is an 8 bit up counter which can reach 256 or 127
- Overflow interrupt
- Match interrupt

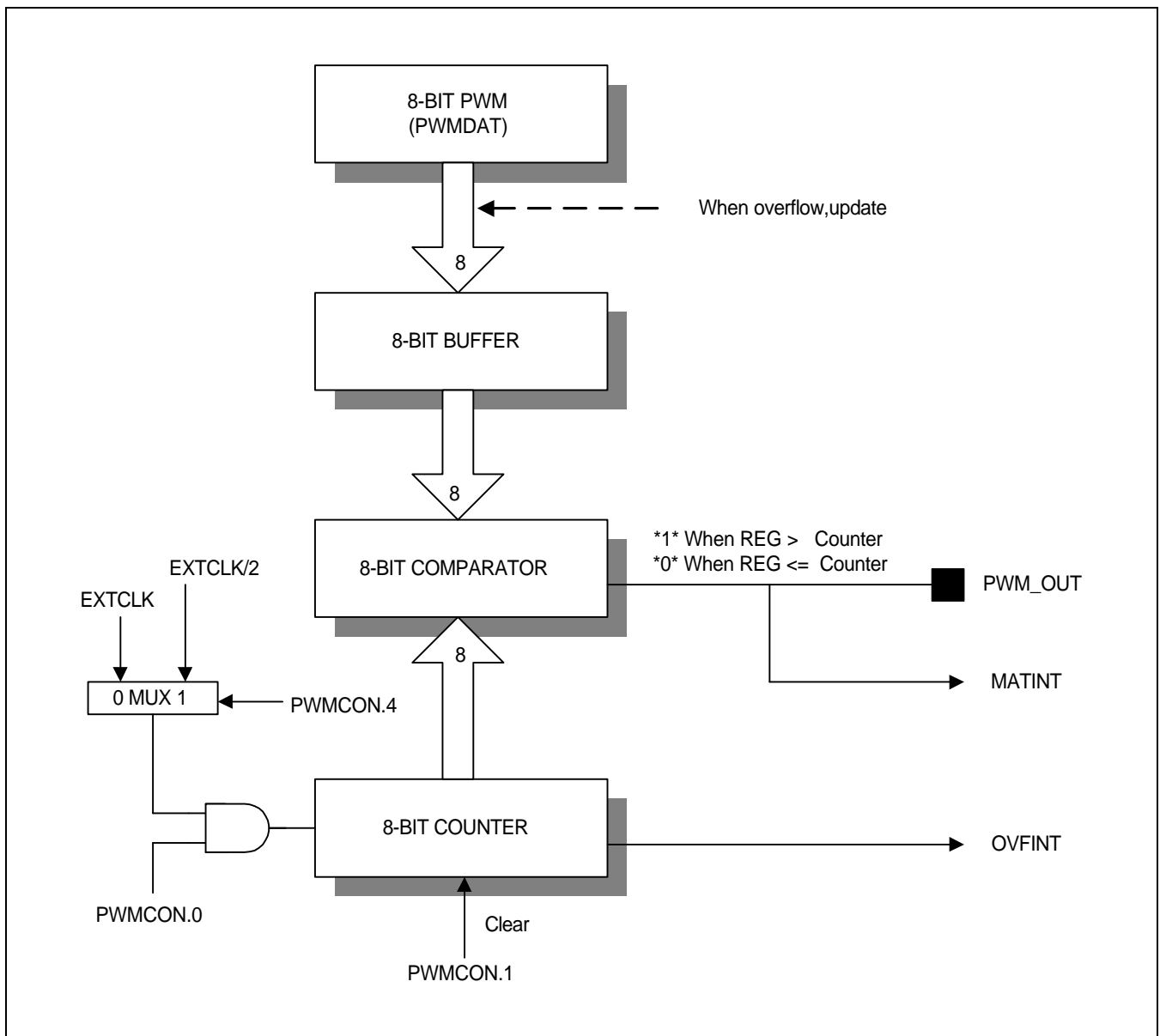

Figure 11-1. 8-Bit PWM Functional Block Diagram

8-BIT PWM CONTROL

In order to control 8 bit PWM, first define counter size 256 (8-bit counter) or 127 (7-bit counter) by setting corresponding register bit (PWMCON.2) and select a divider by 1/1 or by 1/2 (PWMCON.3) As you know, PWM signals high in the range from 0 to PWM data value and in turn low in rest of counts till reaching at the maximum value of counter register. Please set the proper value for the PWMDAT to define pulse width and then for initializing PWM, and then clear PWM Counter (PWMCON.1). The above setting makes PWM ready to start. If you want to trigger PWM counter, Please set PWMCON.0.

Required more details regarding to handling Match/ Overflow interrupt in PWM, please refer to Chapter 8 Interrupt Controller. In a brief, a match interrupt will be occurred at the point of matching with PWM counter and PWMDATA where the pulse turns over. An overflow interrupt is taking place right on the point of rolling over.

8-BIT PWM SPECIAL REGISTERS

PWM CONTROL REGISTER

The PWM control register, PWMCON, is used to control the 8 bit PWM.

Register	Offset Address	R/W	Description	Size	Reset Value
PWMCON	0x6003	R/W	PWM control register	B	00h

[0]	PWM enable	This bit is set to '1' makes PWM run, whereas cleared to '0' then PWM stops.
[1]	PWM counter clear	PWMCON[1] bit is set to 1, which makes PWM counter cleared and after one clock later automatically PWMCON[1] bit is returned to '0',
[2]	PWM counter size selection	This bit PWMCON[2] indicates the total size of counting that reaches top value of PWM counter. When it is 0, 8bits of counter register are fully used, in other words, PWM counter is counting to 256 then rolls over to zero. But it is 1, only 7bits is used to count 127, and then the counter cleared to zero.
[4]	PWM clock selection	When PWMCON[4] is 0, PWM clock is selected as non-divided source of the external clock. When it is 1, PWM clock is selected to the divided one of external clock by 2

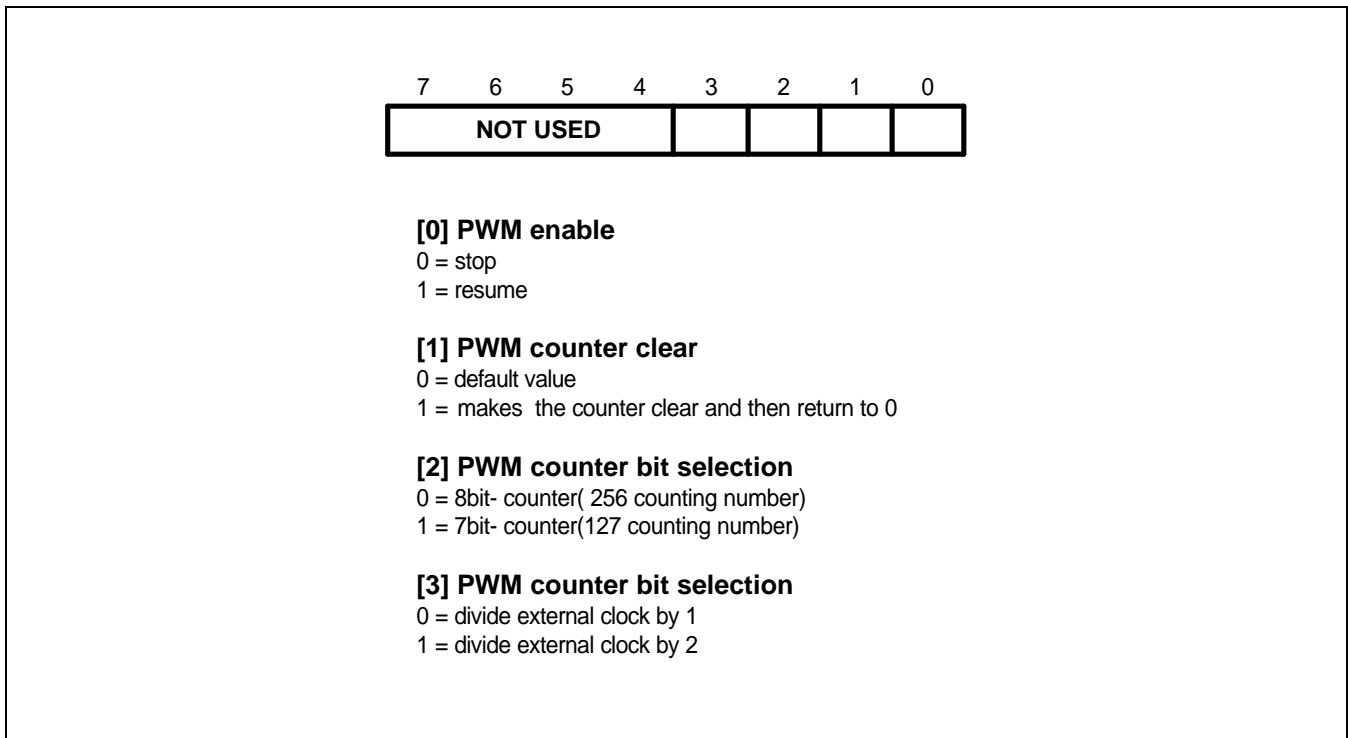

Figure 11-2. PWM Control Register (PWMCON)

PWM DATA REGISTER

The PWM data register, PWMDAT, is used to control pulse width.

Register	Offset Address	R/W	Description	Size	Reset Value
PWMDAT	0x6007	R/W	PWM data register	B	00h

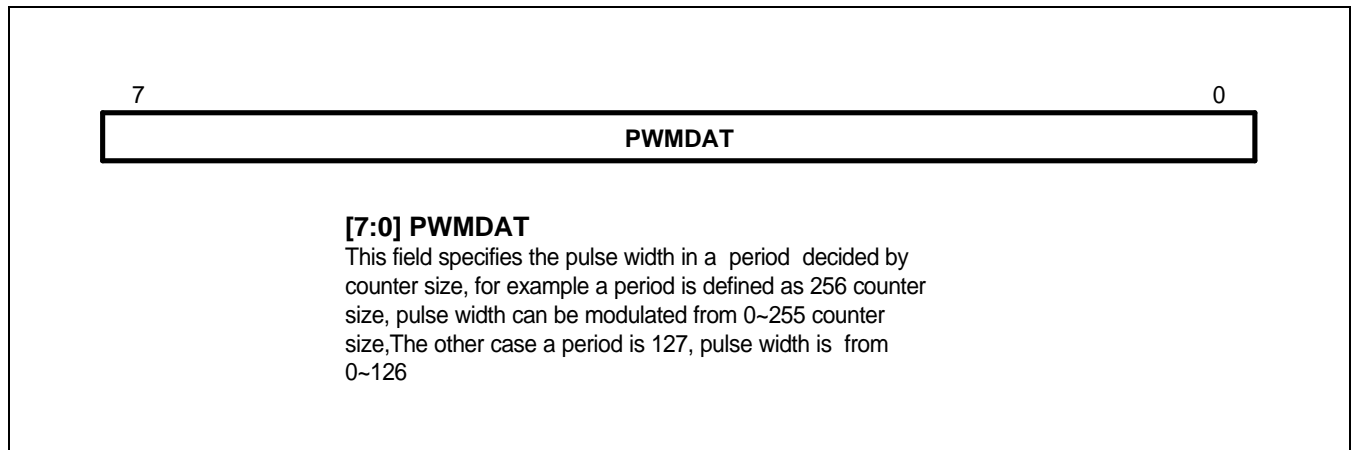

Figure 11-3. PWM Data Registers (PWMDAT)

8-BIT PWM WAVE MODULATION

One period of 8 BIT PWM counter, if mode set 8-bit counter, is composed of 256 clocks while maximum width of PWM Signal is 255 (**Pulse width = PWMDAT-1**), which generates one clock gap between one period and another one. It means that even if PWMDAT is set maximized, there is one clock low signal included in a period. PWM mode set as 7-bit counter has such a gap too. Look up the following wave form diagram to modulate the proper signal.

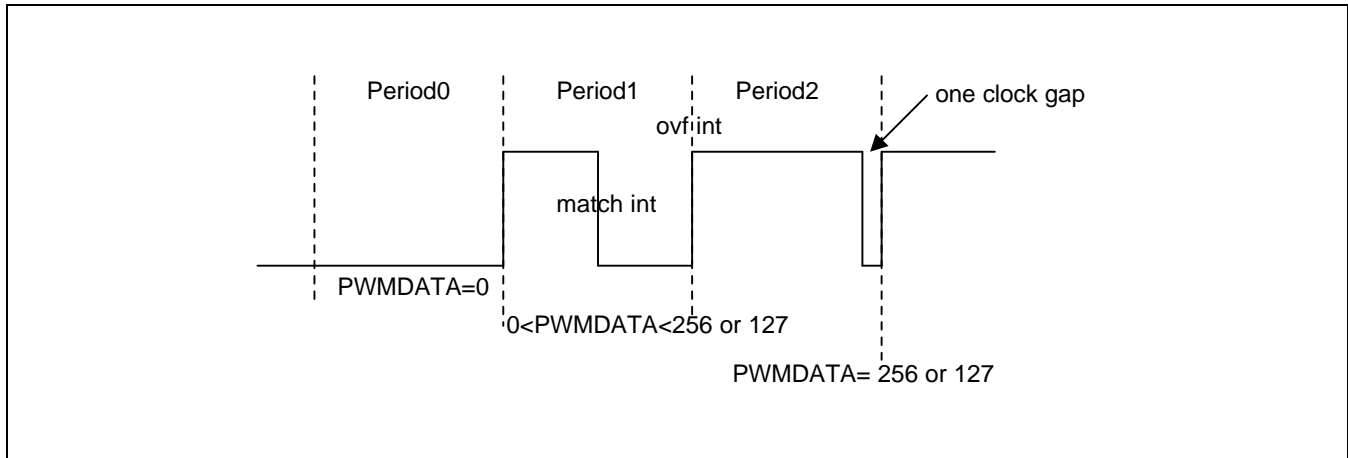

Figure 11-4. PWM Wave

12 SYSTEM CONTROL

POWER-DOWN MODE

In STOP mode, all logic will be stopped. The external interrupts (EINT0,1,2) can wake up the MCU. In IDLE mode, the CPU and the internal flash ROM will be stopped. All enabled interrupts can wake up the MCU.

GLOBAL INTERRUPT CONTROL

All interrupt requests can be disabled by global interrupt control bit.

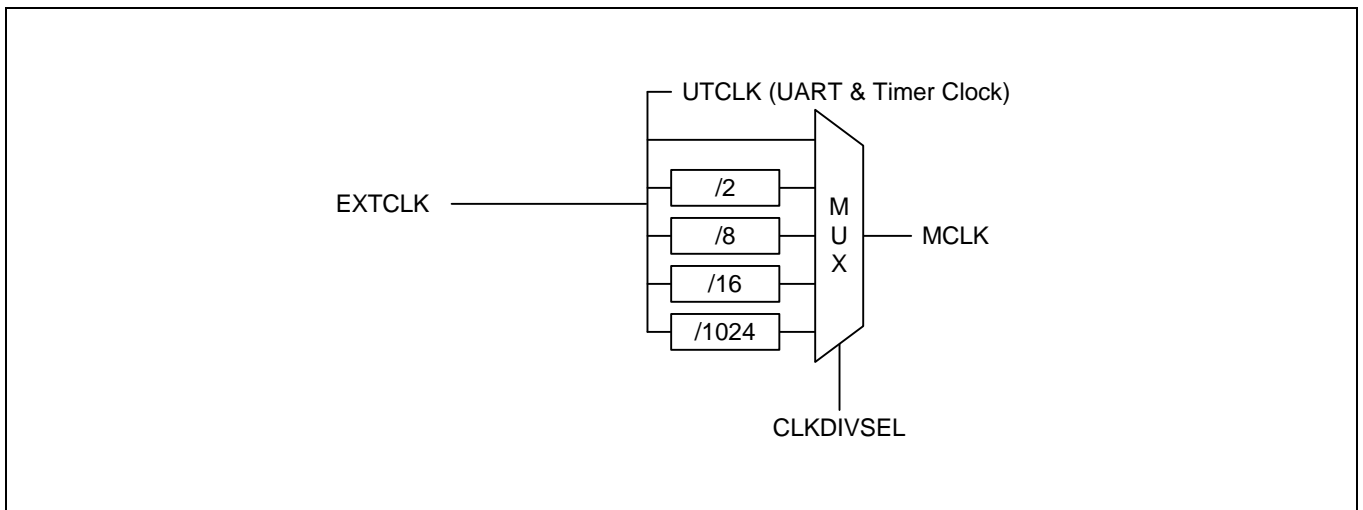

Figure 12-1. Clock Circuit Diagram

ENTERING THE STOP MODE

To enter the stop mode, do the following steps.

1. Set the SYSCON[0] to enter the STOP mode.
2. There has to be at least 4 NOP instructions following the instruction to enter the STOP mode
3. S3F443FX is in STOP mode now.

EXITING FROM THE STOP MODE

To exit from the stop mode, the following steps should be executed. To configure the STOP exiting condition, configure EINTMOD, EINTCON, INTMASK and SYSCON[8] registers.

1. EINT[2:0] will be issued to exit from the STOP mode.

IDLE MODE AND INTERNAL FLASH ROM

In the IDLE mode, the internal flash ROM will be stopped together. Just after exiting the IDLE mode, the interval time (32 MCLKs) for start-up time of the internal flash ROM should be available. This 32 MCLK interval is inserted automatically by H/W logic.

SYSTEM CONTROL REGISTER

The system control register (SYSCON) can be used to control the system operation of chip.

Register	Offset Address	R/W	Description	Reset Value
SYSCON	0xd002	R/W	System Control register	000h

[0]	STOP bit		This bit determines whether the stop mode is enabled or disabled. In STOP mode, all logic will be stopped. The external interrupts (EINT0,1,2) can wake up MCU. This bit will be cleared automatically.
[1]	IDLE bit		This bit determines whether the idle mode is enabled or disabled. In IDLE mode, the CPU and the internal flash ROM will be stopped. All enabled interrupts can wake up MCU. This bit will be cleared automatically
[2]	UNUSED		
[5:3]	CLKDIVSEL		The clock(EXTCLK) is divided by 1,2,8,16, or 1024. This bit determines the divide ratio. 000: 1/16, 001: 1/8, 010: 1/2 011: 1/1 100: 1/1024
[6]	Basic Timer stop bit		0: resume 1: stop bit
[7]	UART stop bit		0: resume 1: stop bit
[8]	Global Interrupt Control		Global Interrupt Enable bit. This bit can mask all interrupt request. When 0, all interrupt request will not be acceptable. 0: Disable all interrupt request 1: Enable the interrupt requests, which are enabled on INTMASK.

NOTE: To make CPU enter into STOP/IDLE mode perfectly, there have to be 4 NOP instructions after the activation of the Stop or Idle mode.

NOTES

13

SPECIAL FUNCTION REGISTERS

OVERVIEW

This chapter describes the S3F443FX Special function registers. 64KB SFR block has an 8KB SRAM area for stack or data memory and special registers to control peripheral blocks.

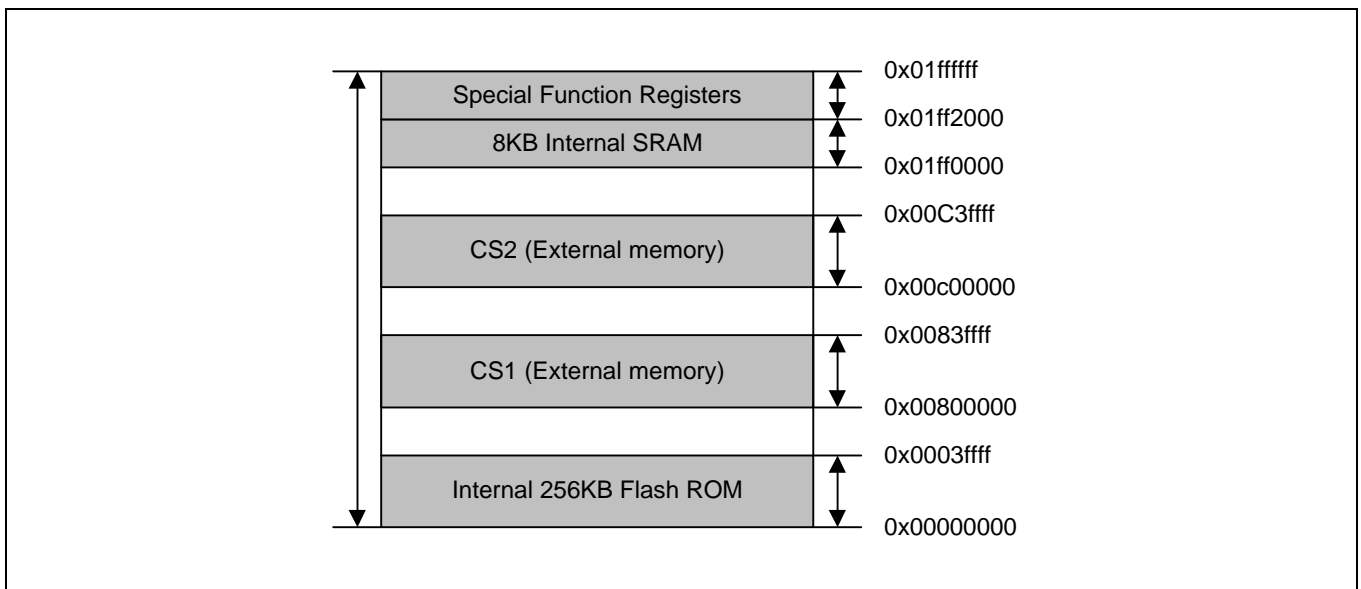

Figure 13-1. S3F443FX Default Memory Map of the Normal Mode (In-ROM mode)

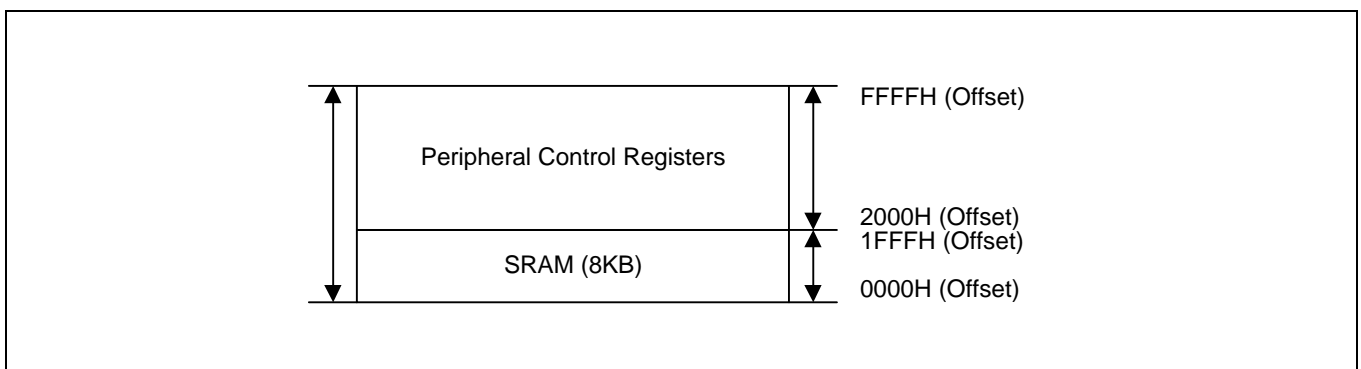

Figure 13-2. Special Function Register

S3F443FX SPECIAL REGISTERS

Table 13-1. S3F443FX Special Registers

Group	Registers	Offset	R/W	Description	Access	Reset Value
System	SYSCFG	0x3000	R/W	System Configuration register	W	1ff1h
Manager	MEMCON0	0x4000	R/W	Memory Bank 0 control register	W	0800 3000h
	MEMCON1	0x4004	R/W	Memory Bank 1 control register	W	0c08 3000h
	MEMCON2	0x4008	R/W	Memory Bank 2 control register	W	100c 3000h
Internal Flash ROM	FMKEY0	0x3010	W	Flash program/erase Key register0	B	00h
	FMKEY1	0x3011	W	Flash program/erase Key register1	B	00h
	FMKEY2	0x3012	W	Flash program/erase Key register2	B	00h
	FMKEY3	0x3013	W	Flash program/erase Key register3	B	00h
	FMADDR	0x3014	R/W	Flash user program address register	W	0 0000h
	FMDATA	0x3018	R/W	Flash user program data register	W	0000 0000h
	FMUCON	0x301f	R/W	Flash program/erase control register	B	00h
	FMACON	0x3027	R/W	Flash access cycle control register	B	03h
	FMERR	0x3023	R/W	Flash error register	B	01h
	FSOREAD	0x3028	R	Smart Option bits read register	W	0000 ffffh
FPOREAD	0x302C	R	Protection Option bits read register	W	0802 01ffh	
UART	LCON	0x5003	R/W	UART line control register	B	00h
	UCON	0x5007	R/W	UART control register	B	00h
	USSR	0x500b	R	UART status register	B	c0h
	TBR	0x500f	W	UART transmit buffer control register	B	xxh
	RBR	0x5013	R	UART receive buffer control register	B	Xxh
	UBRDR	0x5016	R/W	UART baud rate divisor register	H	0000h
PWM	PWMCON	0x6003	R/W	PWM Control Register	B	00h
	PWMDAT	0x6007	R/W	PWM data	B	FFh

NOTE: B: byte (8-bit), H: half-word (16-bit), W: word (32-bit)

Table 13-1. S3F443FX Special Registers (Continued)

Group	Registers	Offset	R/W	Description	Access	Reset Value
Timer 0	T0DATA	0x9000	R/W	Timer 0 data register	H	ffffh
	T0PRE	0x9002	R/W	Timer 0 prescaler register	B	ffh
	T0CON	0x9003	R/W	Timer 0 control register	B	00h
	T0CNT	0x9006	R	Timer 0 counter register	H	0000h
Timer 1	T1DATA	0x9010	R/W	Timer 1 data register	H	ffffh
	T1PRE	0x9012	R/W	Timer 1 prescaler register	B	ffh
	T1CON	0x9013	R/W	Timer 1 control register	B	00h
	T1CNT	0x9016	R	Timer 1 counter register	H	0000h
Timer 2	T2DATA	0x9020	R/W	Timer 2 data register	H	ffffh
	T2PRE	0x9022	R/W	Timer 2 prescaler register	B	ffh
	T2CON	0x9023	R/W	Timer 2 control register	B	00h
	T2CNT	0x9026	R	Timer 2 counter register	H	0000h
Timer 3	T3DATA	0x9030	R/W	Timer 3 data register	H	ffffh
	T3PRE	0x9032	R/W	Timer 3 prescaler register	B	ffh
	T3CON	0x9033	R/W	Timer 3 control register	B	0000h
	T3CNT	0x9036	R/W	Timer 3 counter register	H	00h
Timer 4	T4DATA	0x9040	R/W	Timer 4 data register	H	ffffh
	T4PRE	0x9042	R/W	Timer 4 prescaler register	B	ffh
	T4CON	0x9043	R/W	Timer 4 control register	B	00h
	T4CNT	0x9046	R/W	Timer 4 counter register	H	0000h
Timer 5	T5DATA	0x9050	R/W	Timer 5 data register	H	ffffh
	T5PRE	0x9052	R/W	Timer 5 prescaler register	B	ffh
	T5CON	0x9053	R/W	Timer 5 control register	B	00h
	T5CNT	0x9056	R/W	Timer 5 counter register	H	0000h

NOTE: B: byte (8-bit), H: half-word (16-bit), W: word (32-bit)

Table 13-1. S3F443FX Special Registers (Continued)

Group	Registers	Offset	R/W	Description	Access	Reset Value
BT & WDT	BTCON	0xa002	R/W	Basic timer control register	H/B	0000h
	BTCNT	0xa007	R	Basic timer counter register	B	00h
I/O Port	P0	0xb000	R/W	Port 0 data register	B	xxh
	P1	0xb001	R/W	Port 1 data register	B	xxh
	P2	0xb002	R/W	Port 2 data register	B	xh
	EINTCON	0xb018	R/W	Port 2 external Interrupt Control register	B	0h
	EINTMOD	0xb01a	R/W	Port 2 external Interrupt Mode register	B	00h
I/O Port Control Register	P0CON	0xb010	R/W	Port 0 control register	B	00h
	P1CON	0xb012	R/W	Port 1 control register	H	0000h
	P2CON	0xb014	R/W	Port 2 control register	B	0h
I/O Port Resistor Control	P0PUR	0xb015	R/W	Port 0 pull-up resister control register	B	00h
	P1PUDR	0xb016	R/W	Port 1 pull-up/down resister control.	B	ffh
	P2PUR	0xb017	R/W	Port 2 pull-up resister control register	B	ffh
Interrupt Controller	INTMODE	0xc000	R/W	Interrupt Mode register	W	xxx0 0000h
	INTPEND	0xc004	R/W	Interrupt Pending register	W	xxx0 0000h
	INTMASK	0xc008	R/W	Interrupt Mask register	W	xxx0 0000h
	INTPRI0	0xc00c	R/W	Interrupt priority 0 register	W	0302 0100h
	INTPRI1	0xc010	R/W	Interrupt priority 1 register	W	0706 0504h
	INTPRI2	0xc014	R/W	Interrupt priority 2 register	W	0b0a 0908h
	INTPRI3	0xc018	R/W	Interrupt priority 3 register	W	0f0e 0d0ch
	INTPRI4	0xc01c	R/W	Interrupt priority 4 register	W	1312 1110h
System Control	SYSCON	0xd002	R/W	System Control register	H	000h
	PLLCON	0xd004	R/W	System Control register	W	38080h
Internal SRAM	SRAM	0x0000 – 0x1fff	R/W	Internal 8KB SRAM area	B,H,W	xxh

NOTE: B: byte (8-bit), H: half-word (16-bit), W: word (32-bit)

14 ELECTRICAL DATA

DC ELECTRICAL CHARACTERISTICS

Table 14-1. Absolute Maximum Ratings

($T_A = 25^\circ\text{C}$)

Parameter	Symbol	Conditions	Rating	Unit
Supply voltage	1.8V V_{DD}	–	2.7	V
	3.3V V_{DD}		3.8	
Input voltage	V_{IN}	–	3.8	V
Latch up current	I_{Latch}	–	± 200	mA
Storage temperature	T_{STG}	–	- 65 to + 150	$^\circ\text{C}$

Table 14-2. D.C. Electrical Characteristics

(T_A = 0°C to +70°C, V_{DD} = 2.7–3.6V)

Parameter	Symbol	Conditions	Min	Typ	Max	Unit
Operating Voltage	V _{DD}	Fosc=80MHz 64Pins	2.7	–	3.6	V
Operating temperature	T _A		0	–	70	°C
High level input voltage	V _{IH}	MD1,MD0,nRESET,EXTCLK Schmitt Pad,COMS pad	2.0	–	–	V
Low level input voltage	V _{IL}	MD1,MD0,nRESET,EXTCLK Schmitt Pad,COMS pad	–	–	0.8	V
High level input current 1	I _{IH1}	V _{IN} =V _{SS} , no pull-up resistor	-10	–	10	uA
High level input current 2	I _{IH2}	V _{IN} =V _{SS} , with pull-up resistor	10	33	60	uA
Low level input current 1	I _{IL1}	V _{IN} =V _{DD} , no pull-down resistor	-10	–	10	uA
Low level input current 2	I _{IL2}	V _{IN} =V _{DD} , with pull-down resistor	-60	-33	-10	uA
High level output voltage	V _{OH}	Port0,port1,port2,A0–A11,D0–D7	2.2	–	–	V
Low level output voltage	V _{OL}	Port0,port1,port2,A0–A11, D0–D7	–	–	0.4	V
Operating current	I _{DD1}	V _{DD} = 3.3V, V _{DDin} =1.8V	–	–	50	mA
IDLE mode current	I _{DD2}	V _{DD} = 3.3V, V _{DDin} =1.8V	–	–	10	mA
STOP mode current	I _{DD3}	V _{DD} = 3.3V, V _{DDin} =1.8V	–	–	1	mA
Internal core voltage	V _{DDIN}	Volt for core block	1.65	1.8	1.95	V

NOTE: nRESET (pin #13) has 250Kohm pull-up resistor. So typical high level input current is 13.2 uA.

Table 14-3. Typical Quiescent Supply Current on V_{DD} @IDLE Mode, Flash Tacc=1

Power Mode	30MHz	40MHz	50MHz	60MHz	70MHz	80MHz	Unit
IDLE Core_1.8	0.056	0.073	0.090	0.106	0.121	0.136	mA
System_3.3	0.207	0.226	0.185	0.174	0.184	0.194	mA
IDLE Current	0.263	0.299	0.275	0.280	0.305	0.330	mA

NOTE: The above current measurement is done in the case that the code is running on internal flash ROM & internal SRAM.

Table 14-4. Typical Quiescent Supply Current on V_{DD} @IDLE Mode, Flash Tacc=2

Power Mode	30MHz	40MHz	50MHz	60MHz	70MHz	80MHz	Unit
IDLE Core_1.8	2.529	3.3645	4.1800	4.994	5.822	6.62	mA
System_3.3	0.1958	0.2258	0.2055	0.204	0.1836	0.15	mA
IDLE Current	2.7248	3.5903	4.3855	5.198	6.0056	6.77	mA

NOTE: The above current measurement is done in the case that the code is running on internal flash ROM & internal SRAM.

Table 14-5. Typical Quiescent Supply Current on V_{DD} @STOP Mode

Power Mode	30MHz	40MHz	50MHz	60MHz	70MHz	80MHz	Unit
STOP Core_1.8	0.056	0.073	0.090	0.106	0.121	0.136	mA
System_3.3	0.207	0.226	0.185	0.174	0.184	0.194	mA
STOP Current	0.263	0.299	0.275	0.280	0.305	0.330	mA

NOTES:

1. The above current measurement is done in the case that the code is on internal flash ROM & internal SRAM.
2. The STOP mode current consumption is not independent to the internal flash memory Tacc.

AC ELECTRICAL CHARACTERISTICS

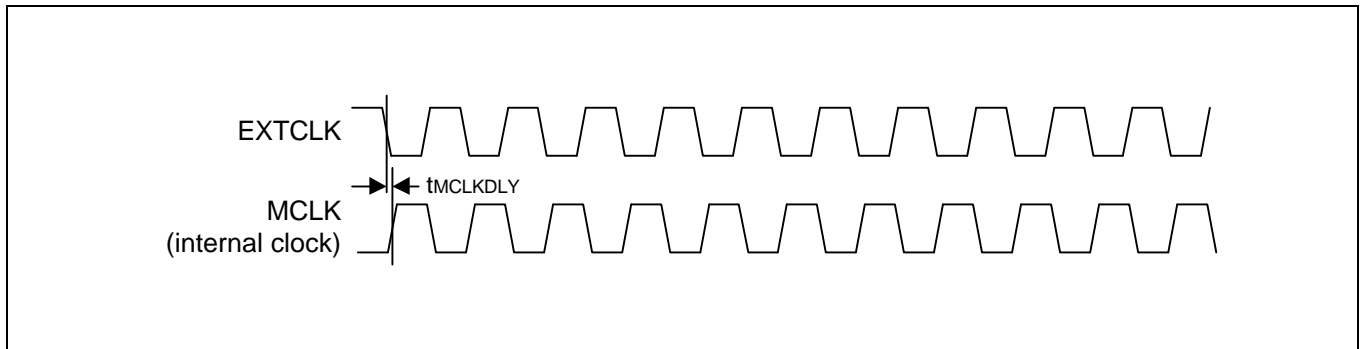

Figure 14-1. EXTCLK and MCLK (Internal Clock) When PLL is not Used.

NOTE

In the figure 14-1, MCLK is the simulated waveform for the case of not using PLL. Because the MCLK can't be shown, all the timing diagram should be drawn only for the case that EXTCLK is signaled by an external clock source without using PLL. Also, all the timing diagram are drawn using the EXTCLK instead of MCLK as a reference clock because only the EXTCLK can be shown.

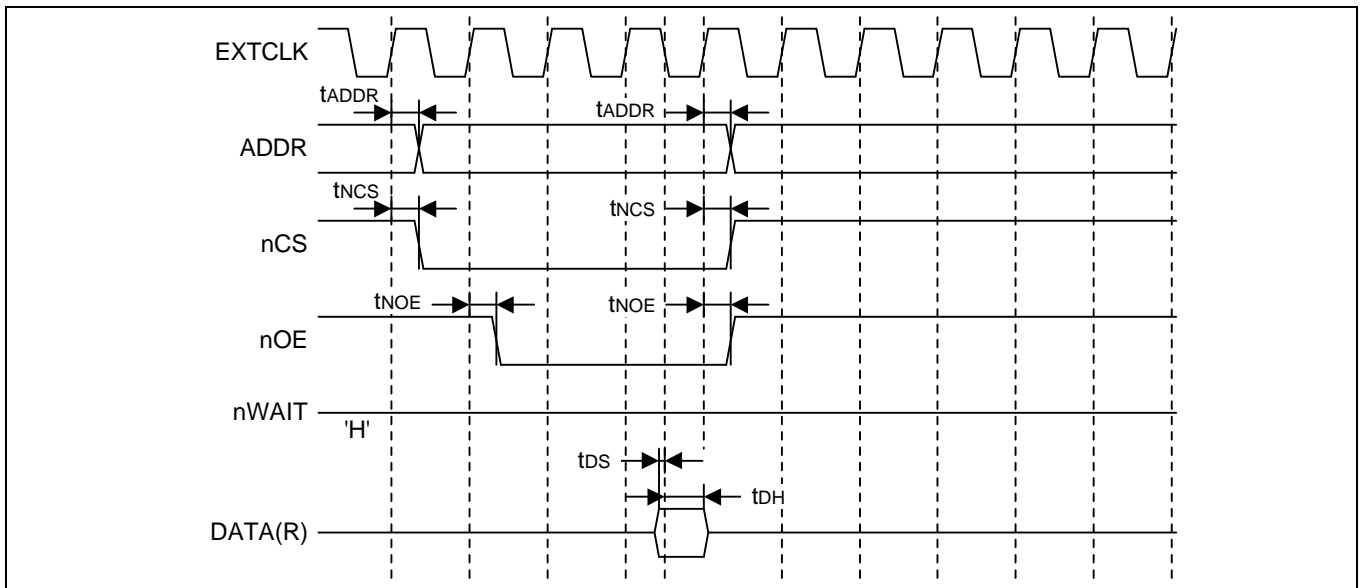

Figure 14-2. SRAM Read Access Timing without nWAIT ($t_{COS}=1, t_{ACS}=0, t_{COH}=0, t_{ACC}=3$)

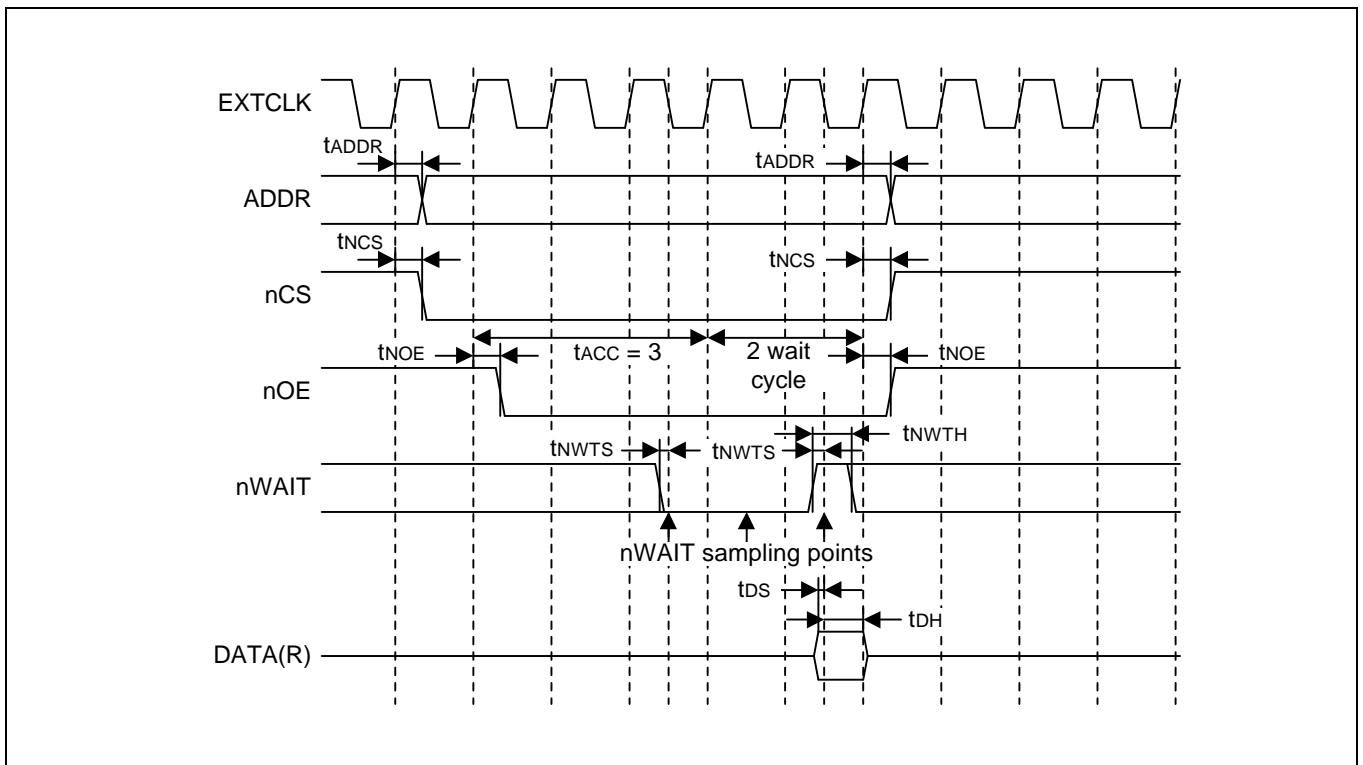

Figure 14-3. SRAM Read Access Timing with nWAIT ($t_{COS}=1, t_{ACS}=0, t_{COH}=0, t_{ACC}=3, \text{external wait}=2$)

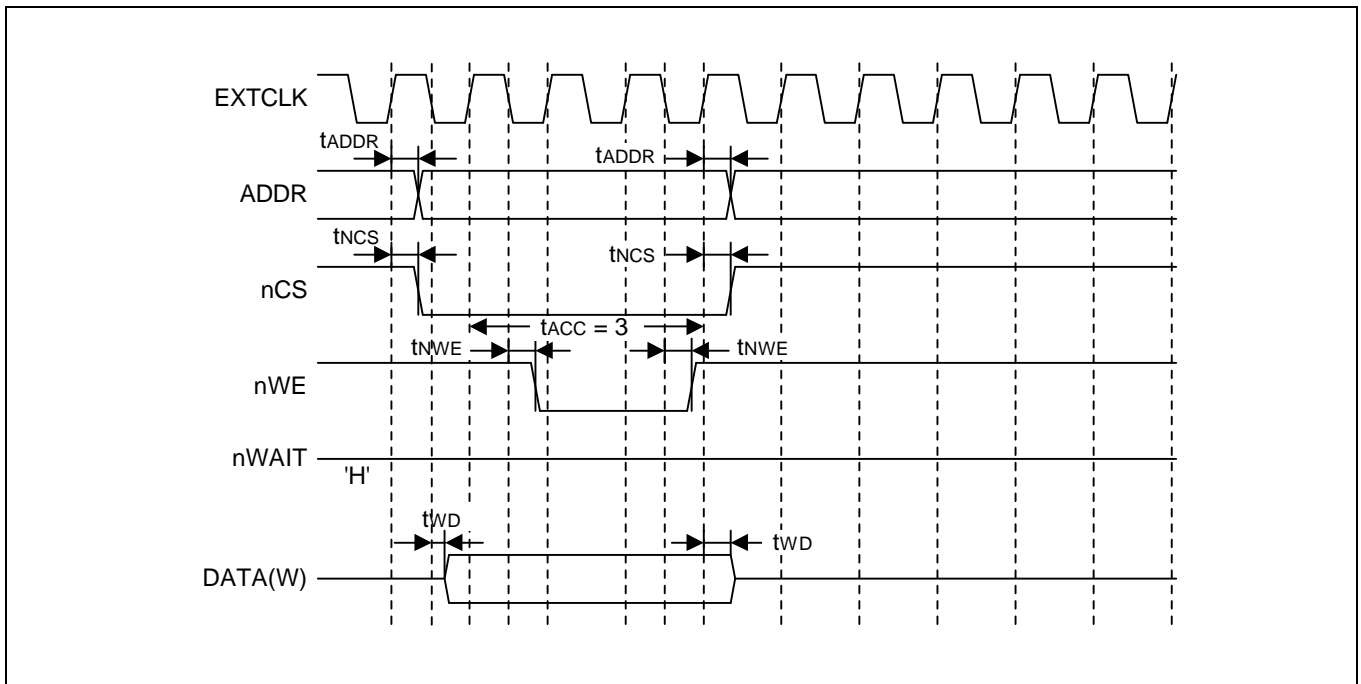

Figure 14-4. SRAM Write Access Timing without nWAIT ($t_{COS}=1$, $t_{ACS}=0$, $t_{COH}=0$, $t_{ACC}=3$)

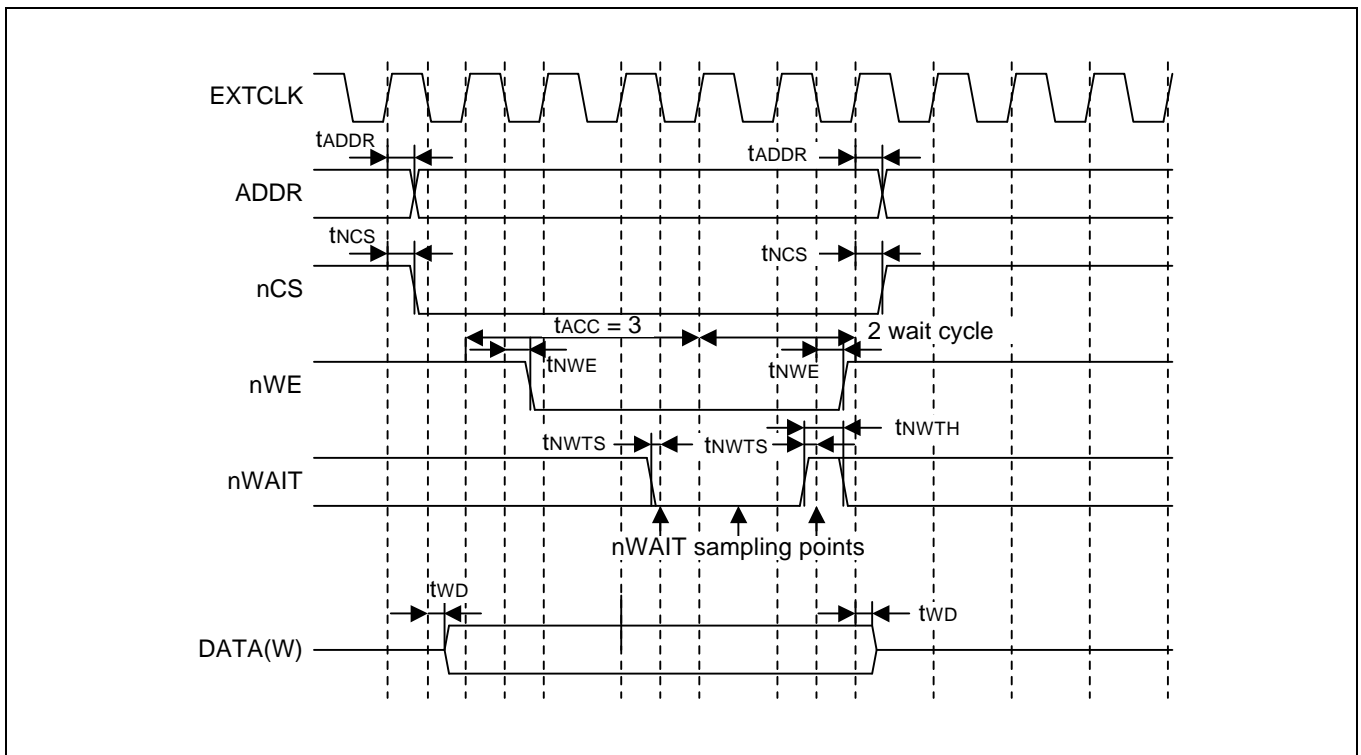

Figure 14-5. SRAM Write Access Timing with nWAIT ($t_{COS}=1$, $t_{ACS}=0$, $t_{COH}=0$, $t_{ACC}=3$, external wait=2)

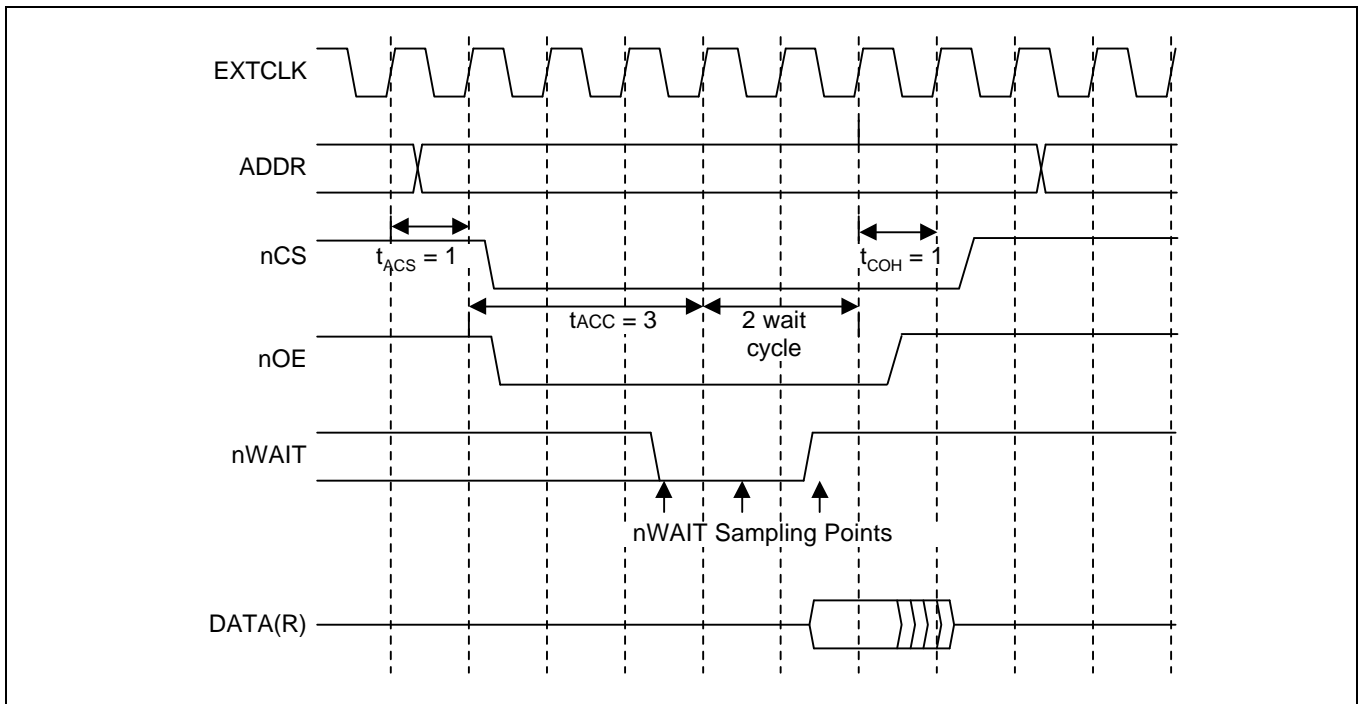

Figure 14-6. SRAM Read Access Timing with nWAIT
 ($t_{COS}=0$, $t_{ACS}=1$, $t_{COH}=1$, $t_{ACC}=3$, external wait = 2)

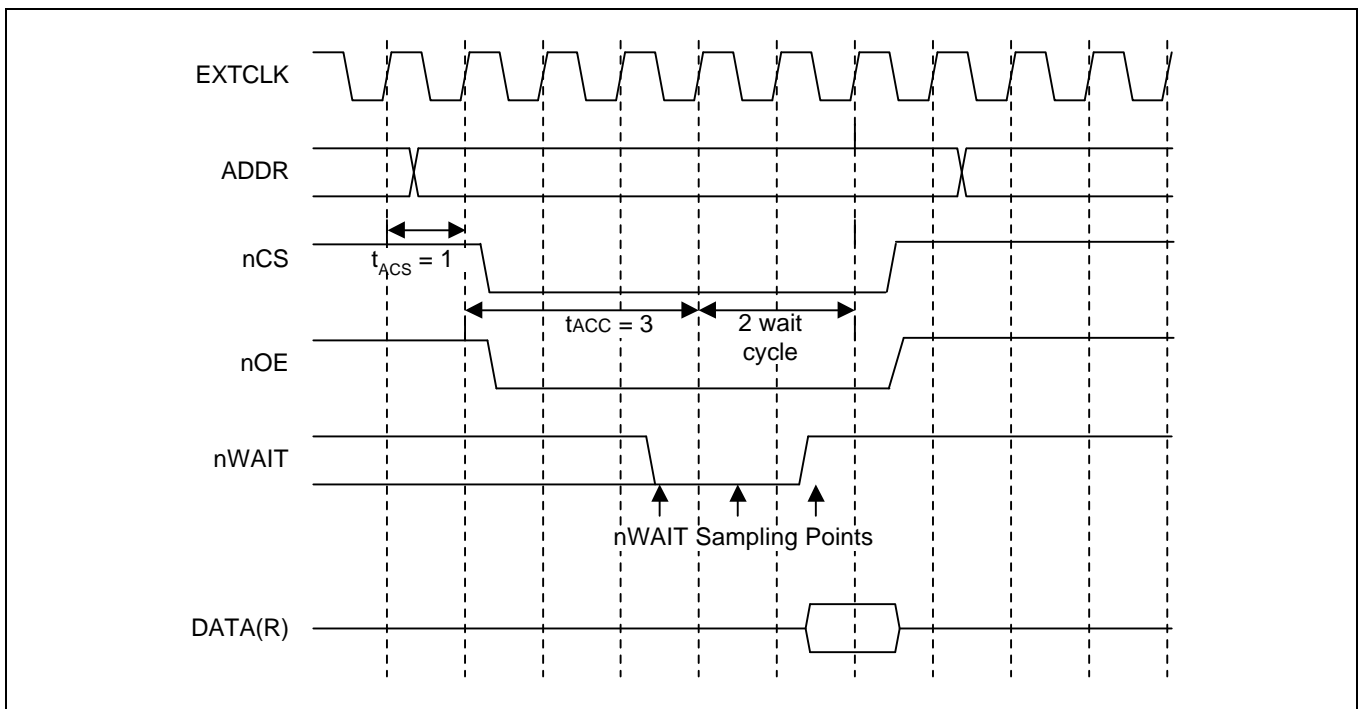

Figure 14-7. SRAM Read Access Timing with nWAIT
 at the Last Cycle of Half-Word/Word Access and Byte Access
 ($t_{COS}=0$, $t_{ACS}=1$, $t_{COH}=0$, $t_{ACC}=3$, external wait = 2)

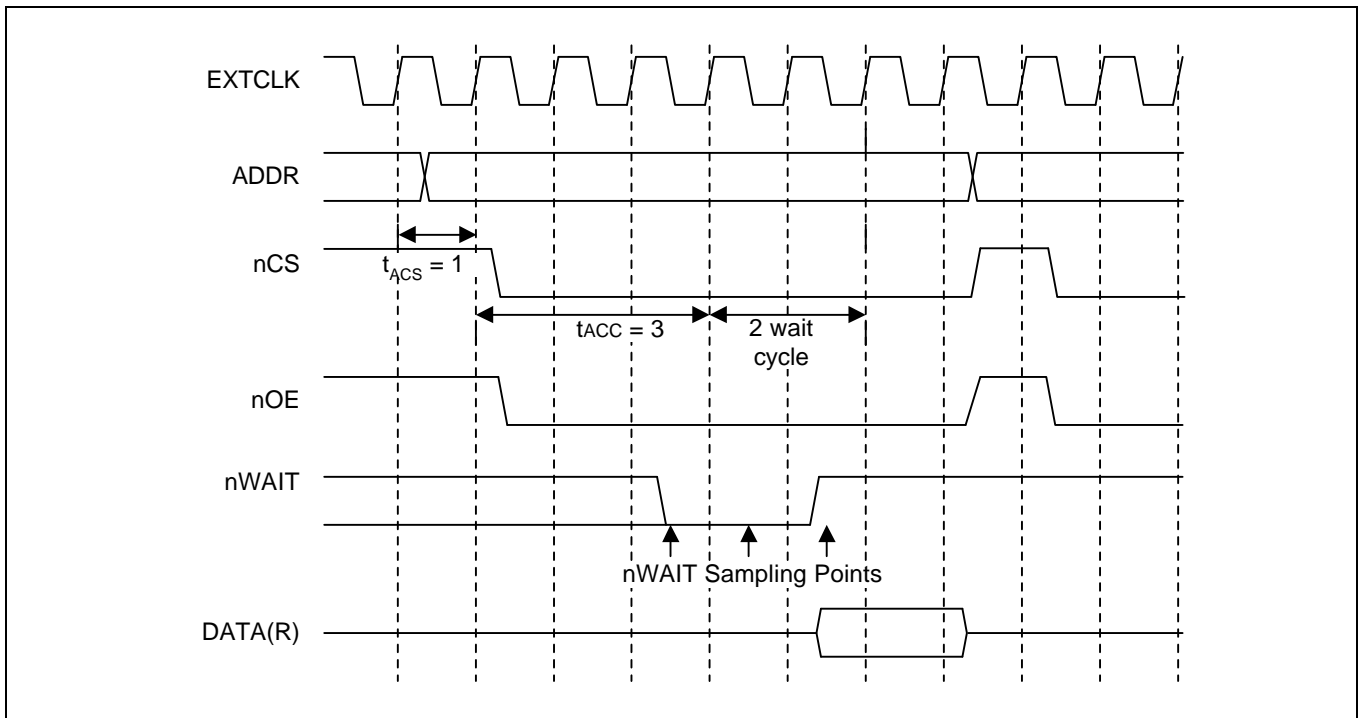
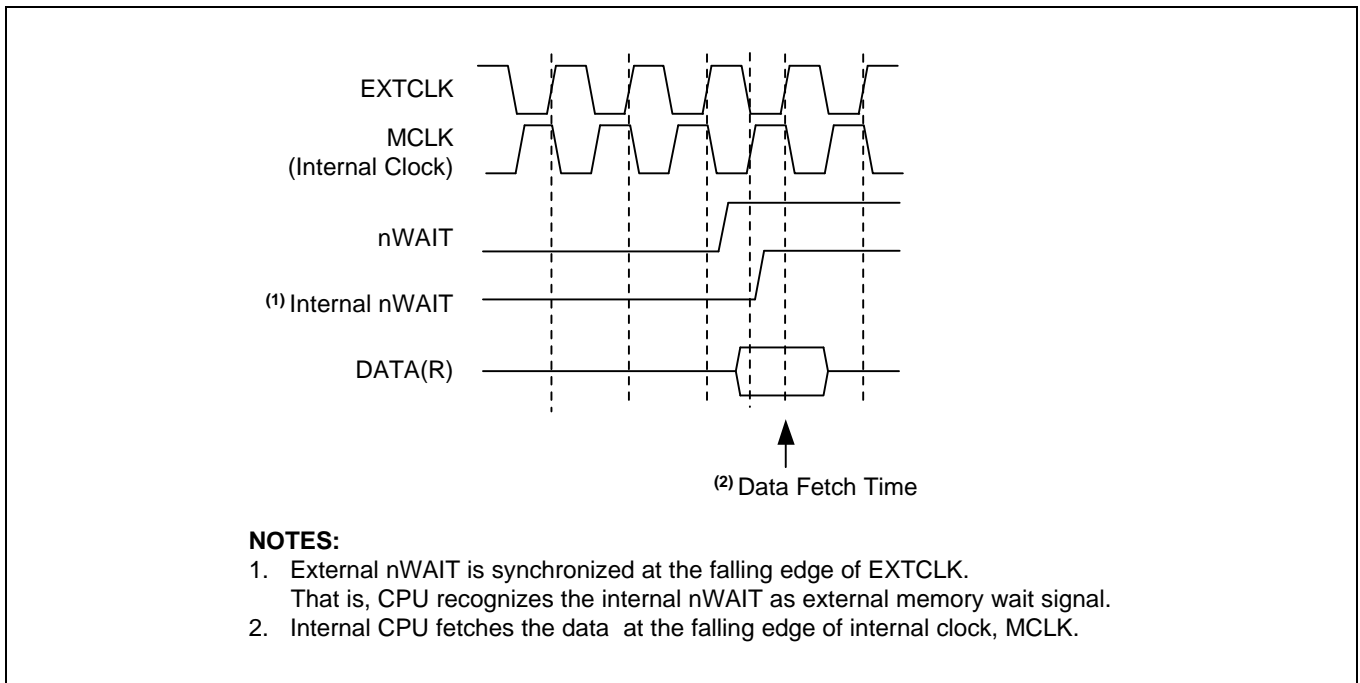

Figure 14-8. SRAM Read Access Timing with nWAIT During Half-Word/Word Access, except the Last Cycle
 (t_{COS}=0, t_{ACS}=1, t_{COH}=0, t_{ACC}=3, external wait = 2)



NOTES:

1. External nWAIT is synchronized at the falling edge of EXTCLK. That is, CPU recognizes the internal nWAIT as external memory wait signal.
2. Internal CPU fetches the data at the falling edge of internal clock, MCLK.

Figure 14-9. nWAIT Data Fetch Timing

Table 14-6. Timing Constants(V_{DD} = 2.7V–3.6V, T_A = 0 °C to +70 °C, operating frequency = 80 MHz)

Parameter	Symbol	Min	Typ	Max	Unit
EXTCLK input frequency when not using PLL	f _{EXTCLK}	0	–	80	MHz
EXTCLK to MCLK delay time	t _{MCLKDLY}		5		ns
Address delay time	t _{ADDR}		–	16	
nCS (chip select) delay time	t _{NCS}		–	14	
nOE (read enable) delay time	t _{NOE}		–	14	
nWE (write enable) delay time	t _{NWE}		–	14	
nWAIT sampling setup time	t _{NWTS}	0	–		
nWAIT sampling hold time	t _{NWTH}	10	–		
Write data delay time	t _{WD}		–	14.5	
Data setup time	t _{DS}	0			
Data hold time	t _{DH}	10			

Table 14-7. AC Electrical Characteristics for Internal Flash ROM(T_A = 0 °C to +70 °C, V_{DD} = 2.7 V–3.6 V)

Parameter	Symbol	Conditions	Min	Typ	Max	Unit
Programming time (1)	Ftp		30	40	50	μS
Chip Erasing Time (2)	Ftp1		37	50	63	mS
Sector Erasing time (3)	Ftp2		37	50	63	mS
Data access time	FtRS		–	25	–	nS
Number of writing /erasing	FNwe	–	–	1,000		Times

NOTES:

1. The programming time is the time during which one word (32-bit) is programmed.
2. The Chip erasing time is the time during which all 256K-byte block is erased.
3. The Sector erasing time is the time during which all 512-byte block is erased.
4. The chip erasing is available in Tool Program Mode only.

NOTES

15 MECHANICAL DATA

PACKAGE DIMENSIONS

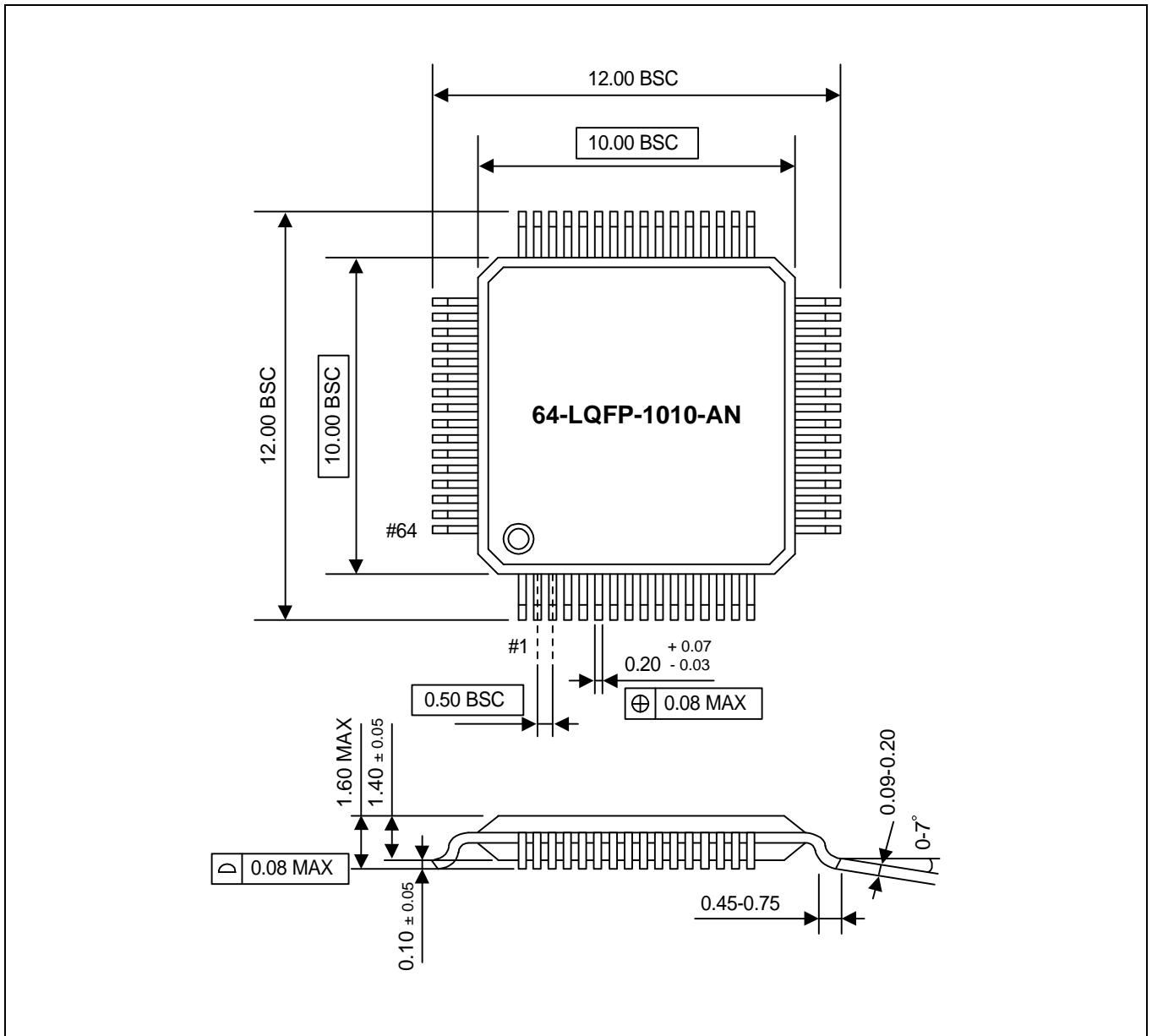

Figure 15-1. 64-LQFP-1010 Package Dimensions (unit: mm)

NOTES