

TOSHIBA Bi-CMOS INTEGRATED CIRCUIT SILICON MONOLITHIC

T B 6 5 2 8 P

FIVE-PHASE STEPPING MOTOR DRIVE CONTROLLER

The TB6528P universal controller for stepping motor drives is a Bi-CMOS monolithic-type IC for controlling five-phase stepping motors.

This IC enables five-phase stepping motor drive units to be configured simply by preparing a pulse oscillator, a switching element and a direct current power source. This IC was developed in order to simplify the use of stepping motors.

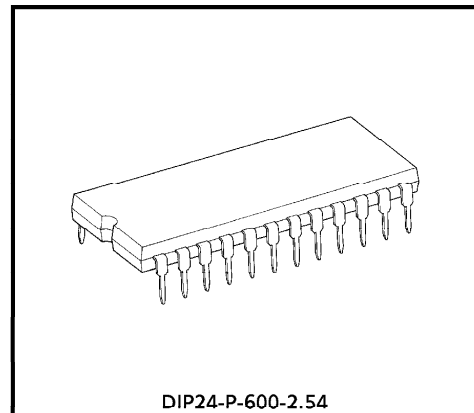

Weight : 3.38g (Typ.)

FEATURES

- Universal controller : The excitation mode switching terminal enables the selection of the following eight modes.
 - Uni-polar type : 2 excitation, 2-3 excitation, 3 excitation
 - Bi-polar type : 2-3 excitation, 3 excitation, 4 excitation, 4-5 excitation, 5 excitation
- Operating supply voltage range : $V_{CC} = 4 \sim 16V$
- High-output current : 20mA min (source)
- High noise margin : All input pin are equipped with a Schmidt circuit.
- Two types of pulse input : 2 input pin method (CW and CCW input modes).
 1 input / 1 switching pin method (CK and U/D input modes). } Either of these can be selected.
- Power down function : All output is at the "L" level

961001EBA1

● TOSHIBA is continually working to improve the quality and the reliability of its products. Nevertheless, semiconductor devices in general can malfunction or fail due to their inherent electrical sensitivity and vulnerability to physical stress. It is the responsibility of the buyer, when utilizing TOSHIBA products, to observe standards of safety, and to avoid situations in which a malfunction or failure of a TOSHIBA product could cause loss of human life, bodily injury or damage to property. In developing your designs, please ensure that TOSHIBA products are used within specified operating ranges as set forth in the most recent products specifications. Also, please keep in mind the precautions and conditions set forth in the TOSHIBA Semiconductor Reliability Handbook.

● The products described in this document are subject to foreign exchange and foreign trade control laws.

● The information contained herein is presented only as a guide for the applications of our products. No responsibility is assumed by TOSHIBA CORPORATION for any infringements of intellectual property or other rights of the third parties which may result from its use. No license is granted by implication or otherwise under any intellectual property or other rights of TOSHIBA CORPORATION or others.

● The information contained herein is subject to change without notice.

- Excitation mode protection function : No fluctuations in output even when switching excitation modes such as 2Ex↔2-3Ex↔3Ex, 4Ex↔4-5Ex↔5Ex.
- Reset function : Moves the phase home position across to the excitation status.
- Phase home position monitor : "H" level is output when at the phase home position (output in the reset mode).
- Excitation status identification monitor : The controller's operating status is output as a monitor signal.
- Input pulse monitor : The input is output as a monitor signal.

BLOCK DIAGRAM

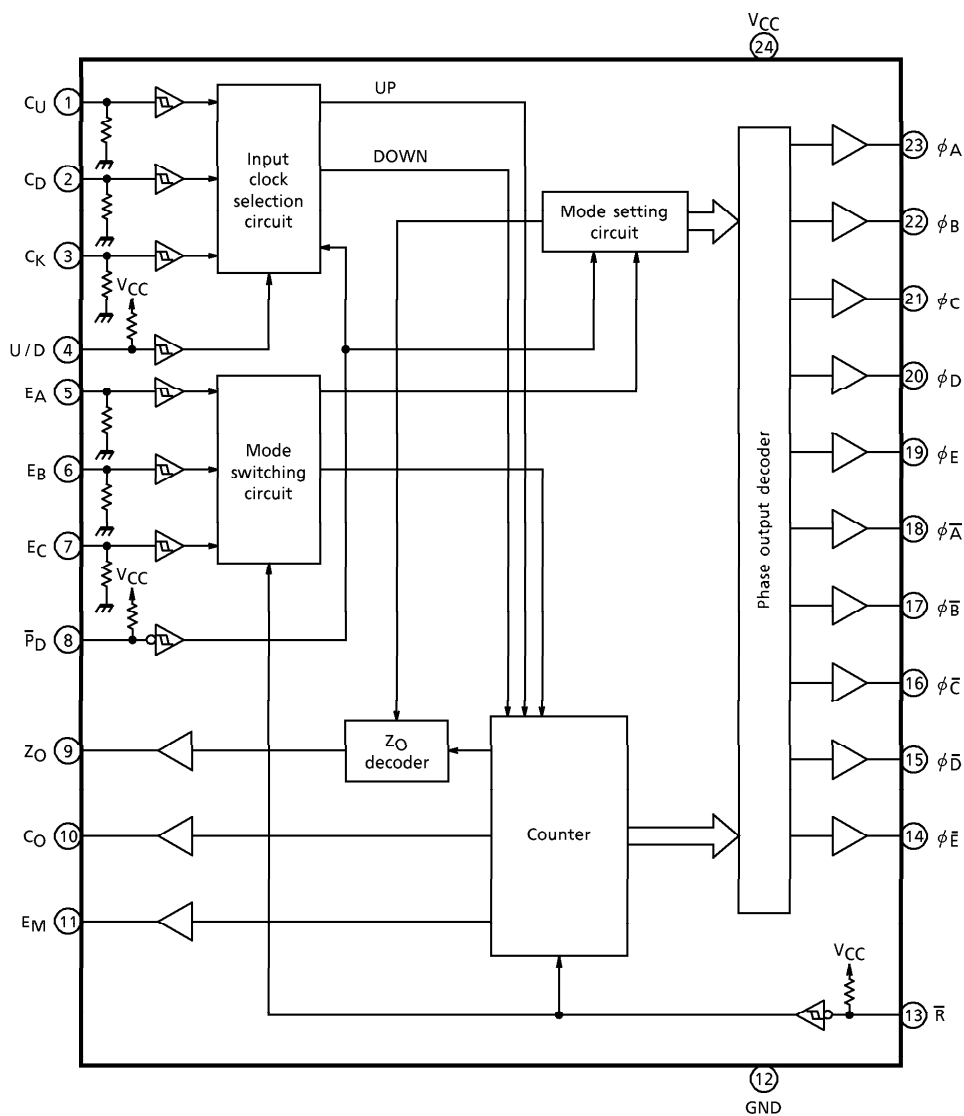

PIN FUNCTION

PIN No.	PIN SYMBOL	PIN FUNCTION
1	C _U	Input pulse UP clock
2	C _D	Input pulse DOWN clock
3	C _K	Input pulse clock
4	U/D	Converts rotation directions "0" is DOWN, "1" is UP
5	E _A	Excitation mode switching input
6	E _B	
7	E _C	
8	P _D	All output becomes "L" when power down is "L"
9	Z _O	Phase home position monitor
10	C _O	Input pulse monitor
11	E _M	Excitation monitor
12	GND	GND
13	\bar{R}	Reset when the reset input is "L"
14	ϕE	ϕE Output
15	ϕD	ϕD Output
16	ϕC	ϕC Output
17	ϕB	ϕB Output
18	ϕA	ϕA Output
19	ϕE	ϕE Output
20	ϕD	ϕD Output
21	ϕC	ϕC Output
22	ϕB	ϕB Output
23	ϕA	ϕA Output
24	V _{CC}	V _{CC}

EQUIVALENT I/O CIRCUIT

C_U, C_D, C_K

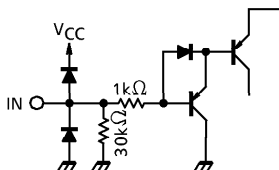

U/D, \bar{P}_D , \bar{R}

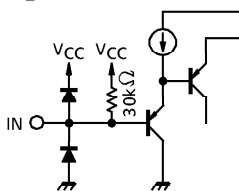



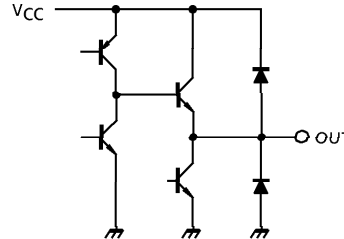

$\phi A \sim \phi E$ and $\phi \bar{A} \sim \phi \bar{E}$

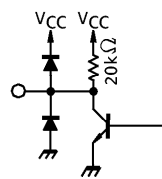

Z_O, C_O, E_M



TRUTH TABLE A

C _U	C _D	C _K	U/D	FUNCTION
	L	L	*	CW
L		L	*	CCW
L	L		H	CW
L	L		L	CCW

- (Note 1) * means Don't Care
- (Note 2) The C_U pin is an input pin when counting up, and the C_D pin is an input pin when counting down.
- (Note 3) The C_K pin is the count pulse input pin, and count-up and count-down is determined by the U/D pin.

TRUTH TABLE B

E _A	E _B	E _C	\bar{R}	\bar{P}_D	FUNCTION	EXCITATION TYPE
L	H	H	H	H	2 Excitation	Uni-polar type
L	L	H	H	H	2-3 Excitation	
H	L	H	H	H	3 Excitation	
H	H	L	H	H	2-3 Excitation	Bi-polar type
H	H	H	H	H	3 Excitation	
L	H	L	H	H	4 Excitation	
L	L	L	H	H	4-5 Excitation	
H	L	L	H	H	5 Excitation	

- (Note 4) The output enters the initial status when \bar{R} is set at the LOW level, and the Z_O output indicates the High level.
- (Note 5) The input clock signal is prohibited and the phase output terminals ($\phi A \sim \phi E$ and $\phi \bar{A} \sim \phi \bar{E}$) enter the LOW level when \bar{P}_D is set at the LOW level. Z_O, C_O and E_M output is not prohibited.

FUNCTION 1 (Uni-polar type)
2 EXCITATION

PHASE \ PULSE	0 (RESET)	1	2	3	4	5
ϕ_A	H	L	L	L	H	H
ϕ_B	H	H	L	L	L	H
ϕ_C	L	H	H	L	L	L
ϕ_D	L	L	H	H	L	L
ϕ_E	L	L	L	H	H	L
$\phi_{\bar{A}}$	L	L	L	L	L	L
$\phi_{\bar{B}}$	L	L	L	L	L	L
$\phi_{\bar{C}}$	L	L	L	L	L	L
$\phi_{\bar{D}}$	L	L	L	L	L	L
$\phi_{\bar{E}}$	L	L	L	L	L	L
ZO	H	L	L	L	L	H
EM	L	L	L	L	L	L
UP	→					
DOWN	←					

2-3 EXCITATION

PHASE \ PULSE	0 (RESET)	1	2	3	4	5	6	7	8	9	10
ϕ_A	H	H	L	L	L	L	L	H	H	H	H
ϕ_B	H	H	H	H	L	L	L	L	L	H	H
ϕ_C	L	H	H	H	H	H	L	L	L	L	L
ϕ_D	L	L	L	H	H	H	H	H	L	L	L
ϕ_E	L	L	L	L	L	H	H	H	H	H	L
$\phi_{\bar{A}}$	L	L	L	L	L	L	L	L	L	L	L
$\phi_{\bar{B}}$	L	L	L	L	L	L	L	L	L	L	L
$\phi_{\bar{C}}$	L	L	L	L	L	L	L	L	L	L	L
$\phi_{\bar{D}}$	L	L	L	L	L	L	L	L	L	L	L
$\phi_{\bar{E}}$	L	L	L	L	L	L	L	L	L	L	L
ZO	H	L	L	L	L	L	L	L	L	L	H
EM	L	H	L	H	L	H	L	H	L	H	L
UP	→										
DOWN	←										

3 EXCITATION

PHASE \ PULSE	0 (RESET)	1	2	3	4	5
ϕA	H	H	L	L	H	H
ϕB	H	H	H	L	L	H
ϕC	L	H	H	H	L	L
ϕD	L	L	H	H	H	L
ϕE	H	L	L	H	H	H
$\phi \bar{A}$	L	L	L	L	L	L
$\phi \bar{B}$	L	L	L	L	L	L
$\phi \bar{C}$	L	L	L	L	L	L
$\phi \bar{D}$	L	L	L	L	L	L
$\phi \bar{E}$	L	L	L	L	L	L
ZO	H	L	L	L	L	H
EM	H	H	H	H	H	H
UP	→					
DOWN	←					

FUNCTION 2 (Bi-polar type)

2-3 EXCITATION

PHASE \ PULSE	0 (RESET)	1	2	3	4	5	6	7	8	9	10	11	12	13	14	15	16	17	18	19	20
$\phi A'$	L	L	L	L	L	L	L	L	L	L	L	H	H	H	H	H	L	L	L	L	L
$\phi B'$	H	H	L	L	L	L	L	L	L	L	L	L	L	L	L	L	L	H	H	H	H
$\phi C'$	L	L	L	H	H	H	H	H	L	L	L	L	L	L	L	L	L	L	L	L	L
$\phi D'$	L	L	L	L	L	L	L	L	L	H	H	H	H	H	L	L	L	L	L	L	L
$\phi E'$	L	L	L	L	L	L	L	L	L	L	L	L	L	L	L	H	H	H	H	H	L
$\phi \bar{A}'$	L	H	H	H	H	H	L	L	L	L	L	L	L	L	L	L	L	L	L	L	L
$\phi \bar{B}'$	L	L	L	L	L	L	L	H	H	H	H	H	L	L	L	L	L	L	L	L	L
$\phi \bar{C}'$	L	L	L	L	L	L	L	L	L	L	L	L	L	H	H	H	H	H	L	L	L
$\phi \bar{D}'$	H	H	H	H	L	L	L	L	L	L	L	L	L	L	L	L	L	L	L	H	H
$\phi \bar{E}'$	L	L	L	L	L	H	H	H	H	H	L	L	L	L	L	L	L	L	L	L	L
ZO	H	L	L	L	L	L	L	L	L	L	L	L	L	L	L	L	L	L	L	L	H
EM	L	H	L	H	L	H	L	H	L	H	L	H	L	H	L	H	L	H	L	H	L
UP	→																				
DOWN	←																				

3 EXCITATION

PHASE \ PULSE	0 (RESET)	1	2	3	4	5	6	7	8	9	10
$\phi A'$	L	L	L	L	L	L	H	H	H	L	L
$\phi B'$	H	H	L	L	L	L	L	L	L	H	H
$\phi C'$	L	L	H	H	H	L	L	L	L	L	L
$\phi D'$	L	L	L	L	L	H	H	H	L	L	L
$\phi E'$	H	L	L	L	L	L	L	L	H	H	H
$\phi \bar{A}'$	L	H	H	H	L	L	L	L	L	L	L
$\phi \bar{B}'$	L	L	L	L	H	H	H	L	L	L	L
$\phi \bar{C}'$	L	L	L	L	L	L	L	H	H	H	L
$\phi \bar{D}'$	H	H	H	L	L	L	L	L	L	L	H
$\phi \bar{E}'$	L	L	L	H	H	H	L	L	L	L	L
ZO	H	L	L	L	L	L	L	L	L	L	H
EM	H	H	H	H	H	H	H	H	H	H	H
UP	→										
DOWN	←										

4 EXCITATION

PHASE \ PULSE	0 (RESET)	1	2	3	4	5	6	7	8	9	10
ϕA	H	L	L	L	L	L	L	H	H	H	H
ϕB	H	H	L	L	L	L	L	L	H	H	H
ϕC	H	H	H	L	L	L	L	L	L	H	H
ϕD	H	H	H	H	L	L	L	L	L	L	H
ϕE	L	H	H	H	H	L	L	L	L	L	L
$\phi \bar{A}$	L	L	H	H	H	H	L	L	L	L	L
$\phi \bar{B}$	L	L	L	H	H	H	H	L	L	L	L
$\phi \bar{C}$	L	L	L	L	H	H	H	H	L	L	L
$\phi \bar{D}$	L	L	L	L	L	H	H	H	H	L	L
$\phi \bar{E}$	L	L	L	L	L	L	H	H	H	H	L
ZO	H	L	L	L	L	L	L	L	L	L	H
EM	L	L	L	L	L	L	L	L	L	L	L
UP	→										
DOWN	←										

4-5 EXCITATION

PHASE \ PULSE	0 (RESET)	1	2	3	4	5	6	7	8	9	10	11	12	13	14	15	16	17	18	19	20	
ϕA	H	H	L	L	L	L	L	L	L	L	L	L	L	H	H	H	H	H	H	H	H	H
ϕB	H	H	H	H	L	L	L	L	L	L	L	L	L	L	L	H	H	H	H	H	H	H
ϕC	H	H	H	H	H	H	L	L	L	L	L	L	L	L	L	L	L	H	H	H	H	H
ϕD	H	H	H	H	H	H	H	H	L	L	L	L	L	L	L	L	L	L	L	H	H	H
ϕE	L	H	H	H	H	H	H	H	H	H	L	L	L	L	L	L	L	L	L	L	L	L
$\phi \bar{A}$	L	L	L	H	H	H	H	H	H	H	H	H	L	L	L	L	L	L	L	L	L	L
$\phi \bar{B}$	L	L	L	L	L	H	H	H	H	H	H	H	H	H	L	L	L	L	L	L	L	L
$\phi \bar{C}$	L	L	L	L	L	L	L	H	H	H	H	H	H	H	H	H	L	L	L	L	L	L
$\phi \bar{D}$	L	L	L	L	L	L	L	L	L	H	H	H	H	H	H	H	H	H	H	L	L	L
$\phi \bar{E}$	L	L	L	L	L	L	L	L	L	L	L	H	H	H	H	H	H	H	H	H	H	L
ZO	H	L	L	L	L	L	L	L	L	L	L	L	L	L	L	L	L	L	L	L	L	H
EM	L	H	L	H	L	H	L	H	L	H	L	H	L	H	L	H	L	H	L	H	L	L
UP	→																					
DOWN	←																					

5 EXCITATION

PHASE \ PULSE	0 (RESET)	1	2	3	4	5	6	7	8	9	10
ϕA	H	H	L	L	L	L	L	H	H	H	H
ϕB	H	H	H	L	L	L	L	L	H	H	H
ϕC	H	H	H	H	L	L	L	L	L	H	H
ϕD	H	H	H	H	L	L	L	L	L	L	H
ϕE	L	H	H	H	H	H	L	L	L	L	L
$\phi \bar{A}$	L	L	H	H	H	H	H	L	L	L	L
$\phi \bar{B}$	L	L	L	H	H	H	H	H	L	L	L
$\phi \bar{C}$	L	L	L	L	H	H	H	H	H	L	L
$\phi \bar{D}$	L	L	L	L	L	H	H	H	H	H	L
$\phi \bar{E}$	H	L	L	L	L	L	H	H	H	H	H
ZO	H	L	L	L	L	L	L	L	L	L	H
EM	H	H	H	H	H	H	H	H	H	H	H
UP	→										
DOWN	←										

MAXIMUM RATINGS (Ta = 25°C)

CHARACTERISTIC	SYMBOL	RATING	UNIT
Power Suplly Voltage	V _{CC}	- 0.5~20	V
Output Current φn	"H" level	I _{OH} φ	- 30
	"L" level	I _{OL} φ	2
Output Current (C _O , E _M , Z _O)	"H" level	I _{OH}	- 50
	"L" level	I _{OL}	2
Input Voltage	V _{IN}	- 0.5~V _{CC}	V
Input Current	I _{IN}	± 1	mA
Power Dissipation	P _D	1000	mW
Operating Temperature	T _{opr}	- 20~85	°C
Storage Temperature	T _{stg}	- 55~150	°C

RECOMMENDED OPERATING CONDITIONS (Ta = - 30~85°C)

CHARACTERISTIC	SYMBOL	TEST CONDITION	MIN.	TYP.	MAX.	UNIT
Power Suplly Voltage	V _{CC}	—	4	—	13	V
Output Current φn	"H" level	I _{OH} φ	—	—	- 10	mA
	"L" level	I _{OL} φ	—	—	1.6	
Output Current (C _O , E _M , Z _O)	"H" level	I _{OH}	—	—	- 40	μA
	"L" level	I _{OL}	—	—	1.6	mA
Input Voltage	V _{IN}	—	0	—	V _{CC}	V
Clock Frequency	—	—	0	—	250	kHz

ELECTRICAL CHARACTERISTICS (Ta = 25°C)

CHARACTERISTIC		SYMBOL	TEST CIR-CUIT	TEST CONDITION	MIN.	TYP.	MAX.	UNIT
Output Current $\phi A \sim \phi E$	"H" level	I_{OH}	—	$V_{CC} = 5V, V_O = V_{CC} - 2.0$	-20	—	—	mA
			—	$V_{CC} = 10V, V_O = V_{CC} - 2.0$	-20	—	—	
	"L" level	I_{OL}	—	$V_{CC} = 5V, V_O = 0.3V$	1.6	—	—	mA
			—	$V_{CC} = 10V, V_O = 0.3V$	1.6	—	—	
Output Current C_O, E_M, Z_O	"H" level	V_{OH}	—	$V_{CC} = 5V, I_O = -40\mu A$	3.6	—	—	V
			—	$V_{CC} = 10V, I_O = -40\mu A$	8.6	—	—	
	"L" level	V_{OL}	—	$V_{CC} = 5V, I_O = 1.6mA$	—	—	0.4	V
			—	$V_{CC} = 10V, I_O = 1.6mA$	—	—	0.6	
Input Voltage	"H" level	V_{IH}	—	$V_{CC} = 5V$	3.0	2.5	—	V
			—	$V_{CC} = 10V$	6.0	5.0	—	
	"L" level	V_{IL}	—	$V_{CC} = 5V$	—	2.0	1.5	V
			—	$V_{CC} = 10V$	—	4.0	3.0	
Input Current C_U, C_D, C_K E_A, E_B, E_C	"H" level	I_{IH}	—	$V_{CC} = 5V, V_{IN} = V_{CC} - 0.5V$	—	—	0.4	mA
			—	$V_{CC} = 10V, V_{IN} = V_{CC} - 0.5V$	—	—	0.7	
	"L" level	I_{IL}	—	$V_{CC} = 5V, V_{IN} = 0V$	—	—	± 10	μA
			—	$V_{CC} = 10V, V_{IN} = 0V$	—	—	± 10	
Input Current $U/D, \bar{P}_D, \bar{R}$	"H" level	I_{IH}	—	$V_{CC} = 5V, V_{IN} = V_{CC} - 0.5V$	—	—	-100	μA
			—	$V_{CC} = 10V, V_{IN} = V_{CC} - 0.5V$	—	—	-100	
	"L" level	I_{IL}	—	$V_{CC} = 5V, V_{IN} = 0V$	—	—	-0.4	mA
			—	$V_{CC} = 10V, V_{IN} = 0V$	—	—	-0.7	
Static Current Consumption		I_{CC}	—	$V_{CC} = 5V, \text{all pins open}$	—	—	25	mA
			—	$V_{CC} = 10V, \text{all pins open}$	—	—	35	

SWITCHING CHARACTERISTICS (Ta = 25°C)

CHARACTERISTIC	SYMBOL	TEST CIR-CUIT	TEST CONDITION	MIN.	TYP.	MAX.	UNIT
Maximum Clock Frequency	f _{MAX}	—	V _{CC} = 5V	250	300	—	kHz
		—	V _{CC} = 10V	270	350	—	
Minimum Clock Pulse Width	t _W	—	V _{CC} = 5V	—	300	500	ns
		—	V _{CC} = 10V	—	300	500	
Minimum Reset Pulse Width	t _{WR}	—	V _{CC} = 5V	—	200	500	ns
		—	V _{CC} = 10V	—	200	500	
Delay Time (φ output from clock input)	t _{PLH}	—	V _{CC} = 5V	—	2500	3500	ns
	t _{PHL}	—	V _{CC} = 10V	—	2500	3500	
Delay Time (each monitor from clock input)	t _{PLH}	—	V _{CC} = 5V	—	3000	4000	ns
	t _{PHL}	—	V _{CC} = 10V	—	3000	4000	
Setting Time	t _{SET}	—	V _{CC} = 5V	4000	3000	—	ns
		—	V _{CC} = 10V	4000	3000	—	
Storage Time	t _{HOLD}	—	V _{CC} = 5V	500	0	—	ns
		—	V _{CC} = 10V	500	0	—	

MEASURED WAVE-FORM FOR SWITCHING TIME

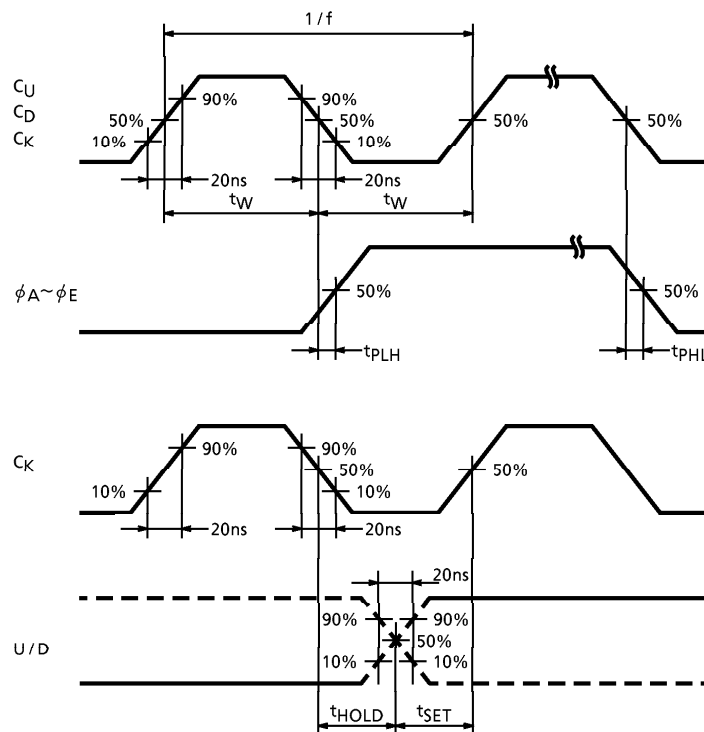

APPLICATION CIRCUIT 1
2 input pin method

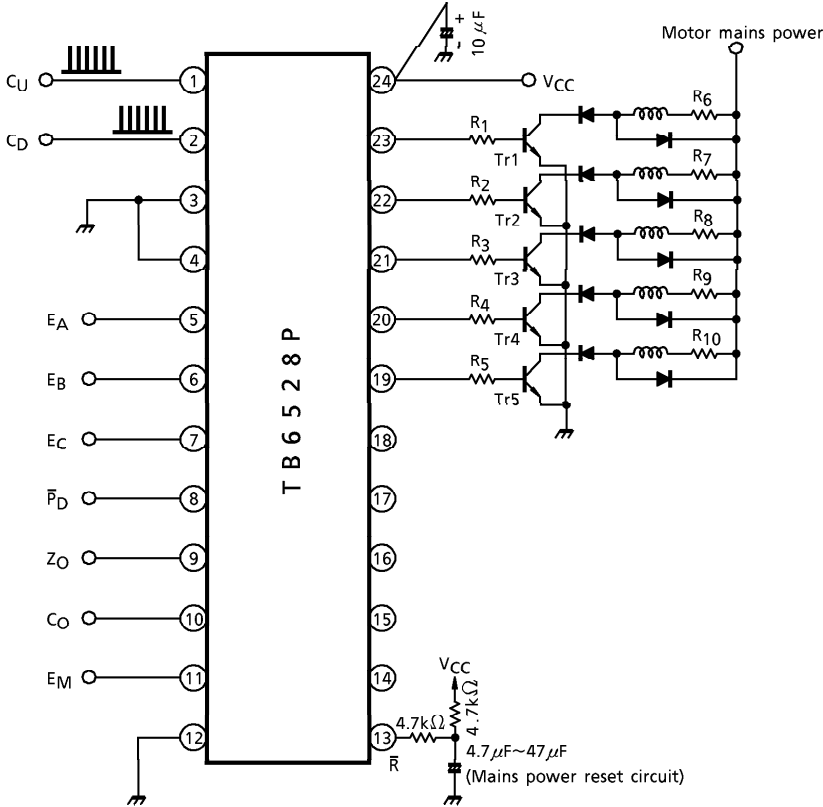

APPLICATION CIRCUIT 2
1 input/switching pin method

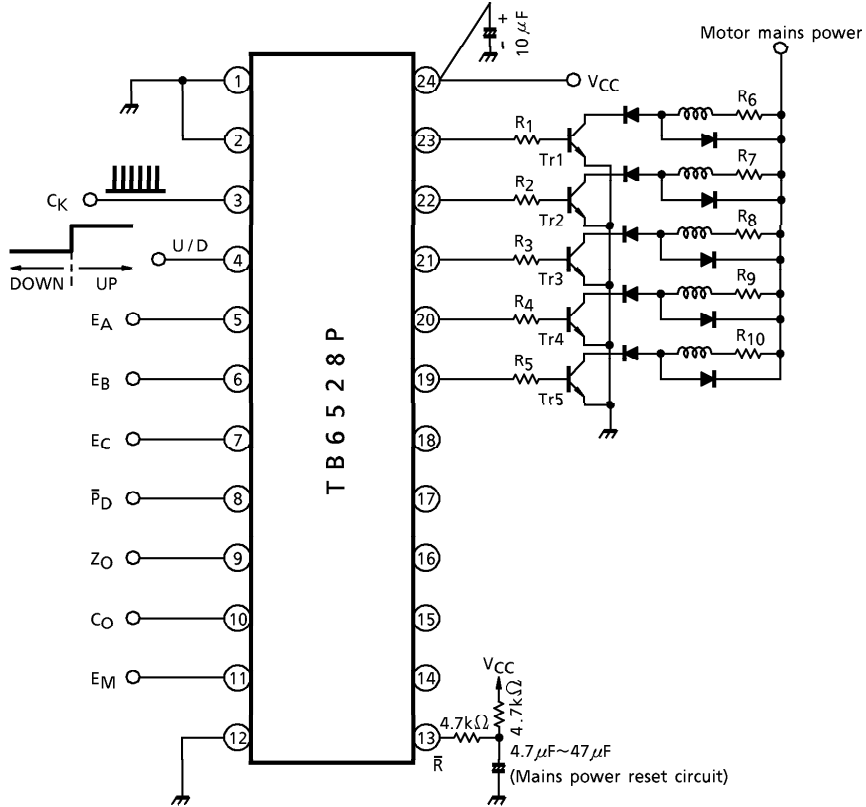

OUTLINE DRAWING
DIP24-P-600-2.54

Unit : mm

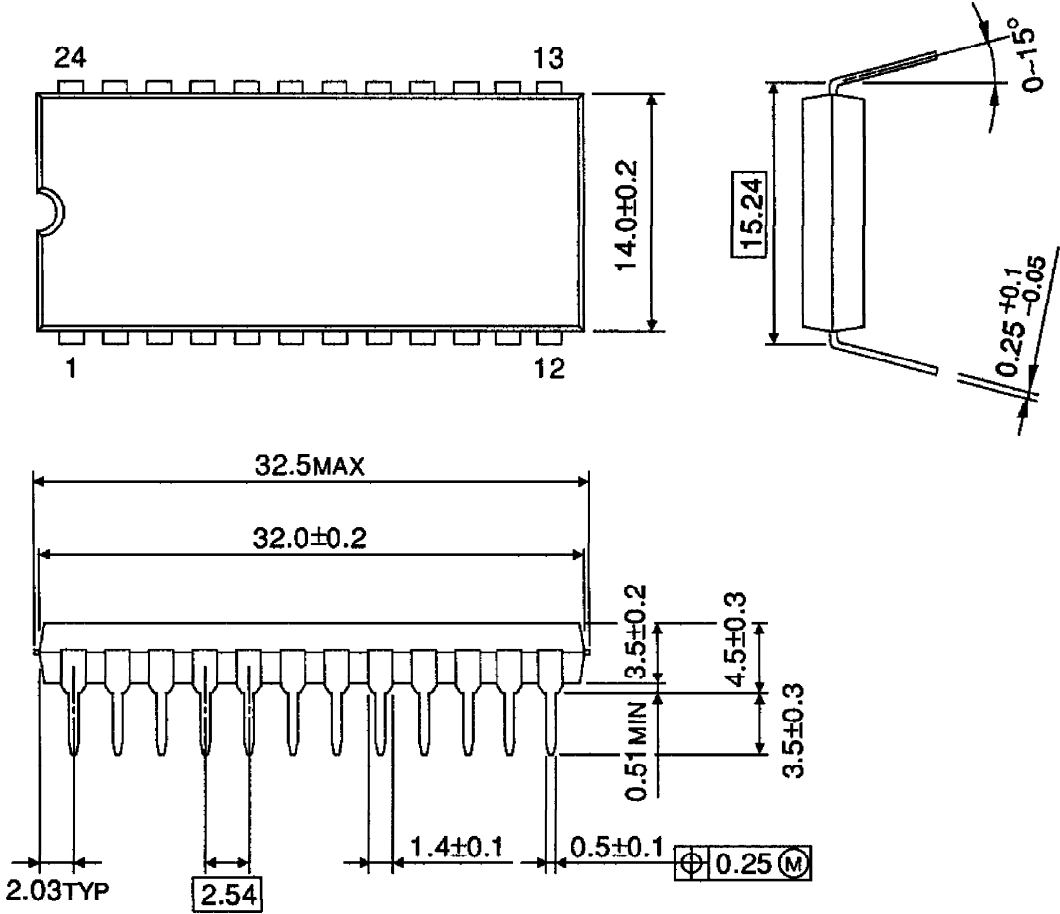

Weight : 3.38g (Typ.)