

- ◆ Synchronous Step-up & down DC / DC Controller
- ◆ Input Voltage Range 2.0V ~ 10.0V
- ◆ Output Voltage Externally Set-up
- ◆ Oscillation Frequency 300 kHz (Accuracy ±15%)
- ◆ Maximum Duty Cycle 78% (TYP.)
- ◆ PWM, PWM/PFM Switching Control
- ◆ Synchronous Rectification Control
- ◆ High Efficiency 84% (TYP.)
- ◆ Small MSOP-8 packaging

■ GENERAL DESCRIPTION

The XC9303 series is highly efficient, synchronous PWM, PWM/PFM switching step-up & down DC/DC controller ICs. A versatile, large output current and high efficiency, step-up/down DC/DC controller can be realized using only basic external components - transistors, coil, diode, capacitors, and resistors for detecting voltages. High efficiency is obtained through the use of a synchronous rectification topology. The operation of the XC9303 series can be switched between synchronous PWM and synchronous PWM/PFM (auto-switching) externally using PWM pin. In PWM/PFM mode the XC9303 automatically switches from PWM to PFM during light loads and high efficiencies can be achieved over a wide range of output loads conditions. Output noise can be easily reduced with PWM control since the frequency is fixed.

The XC9303 has a 0.9V (±2.0%) internal voltage supply and using externally connected components, output voltage can be set freely between 2.0V to 6.0V. With an internal 300kHz switching frequency smaller external components can be used. Soft-start time is internally set to 10msec and offers protection against in-rush currents when the power is switched on and prevents voltage overshoot.

■ TYPICAL APPLICATION CIRCUIT

<XC9303B093K, V_{OUT}:3.3V>

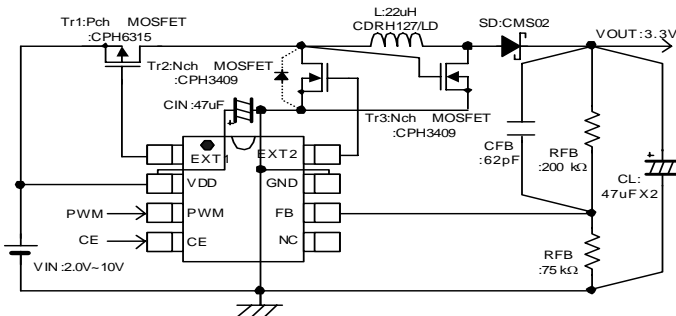

■ APPLICATIONS

- PDAs
- Palmtop computers
- Portable Audio
- Various power supplies

■ FEATURES

Input Voltage Range	: 2.0V ~ 10V
Output Voltage Range	: 2.0V ~ 6.0V Can be set freely with 0.9V (±2.0%) of reference voltage supply and external components.
Oscillation Frequency	: 300kHz ±15%
Output Current	: More than 800mA (VIN = 4.2V, VOUT=3.3V)
Stand-By Function	: 3.0µA (MAX.)
Package	: MSOP-8
Soft-start time	: 10 ms (internally set)

■ TYPICAL PERFORMANCE CHARACTERISTICS

- Efficiency vs. Output Current

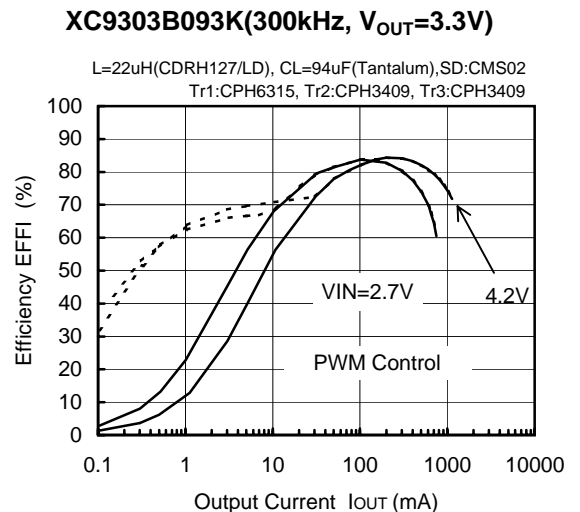

■ PIN CONFIGURATION

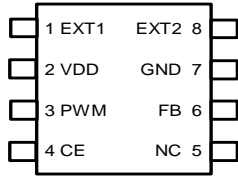

MSOP-8A
(TOP VIEW)

■ PIN ASSIGNMENT

PIN NUMBER	PIN NAME	FUNCTIONS
1	EXT 1 /	External Transistor Drive Pin <Connected to High Side of Pch Power MOSFET Gate>
2	VDD	Supply Voltage
3	PWM	PWM/PFM Switching Pin <PWM control when connected to VDD, PWM / PFM auto switching when connected to Ground. >
4	CE	Chip Enable Pin <Connected to Ground when output is stand-by mode. Connected to VDD when output is active. EXT/1 is high and EXT2/ is low when in stand-by mode.>
5	NC	No Connection
6	FB	Output Voltage Monitor Feedback Pin <Threshold value : 0.9V. Output voltage can be set freely by connecting split resistors between VOUT and Ground.>
7	GND	Ground
8	EXT2	External Transistor Drive Pin <Connected to Low side of Nch Power MOSFET Gate>

■ ORDERING INFORMATION

XC9303①②③④⑤⑥

DESIGNATOR	SYMBOL	DESCRIPTION	
①	B	Standard	
②	0	FB Voltage	
③	9	0.9V	
④	3	Switching Frequency 300kHz	
⑤	K	Package	MSOP-8A
⑥	R	Embossed Tape	Standard Feed
	L		Reverse Feed

■ PACKAGE INFORMATION

○ MSOP-8A

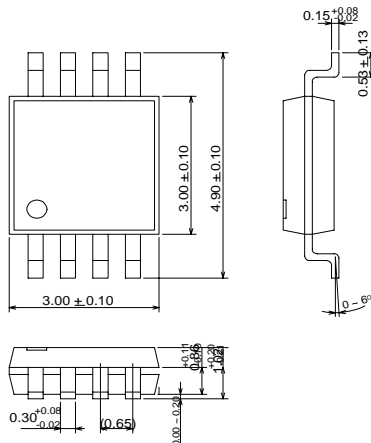

■ ELECTRICAL CHARACTERISTICS

XC9303B093

(FOSC = 300kHz)

Ta=25°C

PARAMETER	SYMBOL	CONDITIONS	MIN.	TYP.	MAX.	UNITS	TEST CIRCUIT
Supply Voltage	VDD	MODE = 0V	2.0	-	10.0	V	①
Maximum Input Voltage	VIN	MODE = 0V	10.0	-	-	V	①
Output Voltage Range(note 1)	VOUTSET	VIN ≥ 2.0V, IOUT=1mA	2.0	-	6.0	V	①
Supply Current 1	IDD1	FB = 0V	-	90	170	μA	②
Supply Current 2	IDD2	FB = 1.0V	-	55	110	μA	②
Stand-by Current	ISTB	Same as IDD1, CE = 0V	-	-	3.0	μA	②
Oscillation Frequency	FOSC	Same as IDD1	255	300	345	kHz	②
FB Voltage	VFB	VIN=3.0V, IOUT=10mA	0.882	0.900	0.918	V	③
Minimum Operation Voltage	VINmin		-	-	2.0	V	①
Maximum Duty Ratio	MAXDTY	Same as IDD1	72	78	88	%	②
Minimum Duty Ratio	MINDTY	Same as IDD2	-	-	0	%	②
PFM Duty Ratio	PFMDTY	No Load, VPWM=0V	22	30	38	%	④
Efficiency1 (note 2)	EFFI	IOUT1=300mA (note 3)	-	84	-	%	④
Soft-Start Time	TSS	VOUT × 0.95V, CE=0V→0.65V	5.0	10.0	20.0	mS	④
EXT1 "High" ON Resistance	REXTBH1	CE1 = 0, EXT1= VDD - 0.4V	-	26	37	Ω	⑤
EXT1 "Low" ON Resistance	REXTBL1	FB = 0V, EXT1 = 0.4V	-	19	30	Ω	⑤
EXT2 "High" ON Resistance	REXTBH2	EXT2 = VDD - 0.4V	-	23	31	Ω	⑤
EXT2 "Low" ON Resistance	REXTBL2	CE = 0V, EXT2 = VDD - 0.4V	-	19	30	Ω	⑤
PWM "High" Voltage	VPWMH	No Load	0.65	-	-	V	④
PWM "Low" Voltage	VPWML	No Load	-	-	0.20	V	④
CE "High" Voltage	VCEH	FB = 0V	0.65	-	-	V	②
CE "Low" Voltage	VCEL	FB = 0V	-	-	0.2	V	②
CE "High" Current	ICEH		-	-	0.5	μA	②
CE "Low" Current	ICEL	CE = 0V	-	-	-0.5	μA	②
PWM "High" Current	IPWMH		-	-	0.5	μA	②
PWM "Low" Current	IPWML	PWM=0V	-	-	-0.5	μA	②
FB "High" Current	IFBH		-	-	0.50	μA	②
FB "Low" Current	IFBL	FB = 1.0V	-	-	-0.50	μA	②

Unless otherwise stated, VDD = 3.0V, CE = 3.0V, PWM = 3.0V, FB = 3.0V, EXT1, 2=OPEN, VIN=2.7V

- Notes
- 1) Please be careful not to exceed the breakdown voltage level of the peripheral parts.
 - 2) $EFFI = \left(\frac{(\text{Output voltage}) \times (\text{Output current})}{(\text{Input voltage}) \times (\text{Input Current})} \right) \times 100$
 - 3) Tr1 : CPH6315 (SANYO)
 Tr2 : CPH3409 (SANYO)
 Tr3 : CPH3409 (SANYO)
 SD : CMS02 (TOSHIBA)
 L : 22μH (SUMIDA CDRH127/LD)
 CL : 16V, 47μF x 2 (NICHICEMI Tantalum MCE Series)
 CIN : 16V, 47μF (NICHICEMI Tantalum MCE Series)
 RFB1 : 200kΩ
 RFB2 : 75kΩ
 CFB : 62pF

■ OPERATIONAL DESCRIPTION

The XC9303 series are synchronous step-up & down DC/DC converter controller ICs with built-in high speed, low ON resistance drivers.

<Error Amp>

The Error Amplifier is designed to monitor the output voltage and it compares the feedback voltage (FB) with the reference voltage. In response to feedback of a voltage lower than the reference voltage, the output voltage of the error amp. decreases.

<OSC Generator>

This circuit generates the oscillation frequency which in turn generates the source clock.

<Ramp Wave Generator>

The Ramp Wave Generator generates a saw-tooth waveform based on outputs from the Phase Shift Generator.

<PWM Comparator>

The PWM Comparator compares outputs from the Error Amp. and saw-tooth waveform. When the voltage from the Error Amp's output is low, the external switch will be set to ON.

<PWM/PFM Controller>

This circuit generates PFM pulses.

Control can be switched between PWM control and PWM/PFM automatic switching control using external signals.

The PWM/PFM automatic switching mode is selected when the voltage of the PWM pin is less than 0.2V, and the control switches between PWM and PFM automatically depending on the load. As the PFM circuit generates pulses based on outputs from the PWM comparator, shifting between modes occurs smoothly. PWM control mode is selected when the voltage of the PWM pin is more than 0.65V. Noise is easily reduced with PWM control since the switching frequency is fixed.

Control suited to the application can easily be selected which is useful in audio applications, for example, where traditionally, efficiencies have been sacrificed during stand-by as a result of using PWM control (due to the noise problems associated with the PFM mode in stand-by).

<Synchronous, blank logic>

The synchronous, blank logic circuit is to prevent penetration of the transistor connected to EXT1 and EXT2.

<Vref with Soft Start>

The reference voltage, Vref (FB pin voltage)=0.9V, is adjusted and fixed by laser trimming (for output voltage settings, please refer to page 8). To protect against inrush current, when the power is switched on, and also to protect against voltage overshoot, soft-start time is set internally to 10ms. It should be noted, however, that this circuit does not protect the load capacitor (CL) from inrush current. With the Vref voltage limited and depending upon the input to the error amps, the operation maintains a balance between the two inputs of the error amps and controls the EXT pin's ON time so that it doesn't increase more than is necessary.

<Chip Enable Function>

This function controls the operation and shutdown of the IC. When the voltage of the CE pin is 0.2V or less, the mode will be chip disable, the channel's operations will stop. The EXT1 pin will be kept at a highlevel (the external P-type MOSFET will be OFF) and the EXT2 pin will be kept at a lowlevel (the external N-type MOSFET will be OFF). When CE pin is in a state of chip disable, current consumption will be no more than 3.0 μ A.

When the CE pin's voltage is 0.65V or more, the mode will be chip enable and operations will recommence. With soft-start, 95% of the set output voltage will be reached within 10mS (TYP) from the moment of chip enable.

■ HOW TO USE

<Setting of Output Voltage>

Output voltage can be set by adding external split resistors. Output voltage is determined by the following equation, based on the values of RFB11(RFB21) and RFB12(RFB22). The sum of RFB11(RFB21) and RFB12(RFB22) should normally be 1 MΩ or less.

$$V_{OUT} = 0.9 \times (R_{FB11} + R_{FB12}) / R_{FB12}$$

The value of CFB1(CFB2), speed-up capacitor for phase compensation, should be $f_{zfb} = 1 / (2 \times \pi \times C_{FB1} \times R_{FB11})$ which is equal to 12kHz. Adjustments are required from 1kHz to 50kHz depending on the application, value of inductance (L), and value of load capacity (CL).

[Example of Calculation] When RFB11 = 200kΩ and RFB12 = 75kΩ, $V_{OUT1} = 0.9 \times (200K + 75k) / 75k = 3.3V$.

[Typical Example]

VOUT (V)	RFB11 (kΩ)	RFB12 (kΩ)	CFB1 (pF)	VOUT (V)	RFB11 (kΩ)	RFB12 (kΩ)	CFB1 (pF)
2.0	330	270	39	3.3	200	75	62
2.2	390	270	33	5.0	82	18	160
2.5	390	220	33				
2.7	360	180	33				
3.0	560	240	24				

[External Components]

Tr 1 : CPH6315 (Pch MOSFET : SANYO), IRLM6702 (Pch MOSFET : IR)

Tr 2 : CPH3409 (Nch MOSFET : SANYO), IRLM1902 (Nch MOSFET : IR)

Tr 3 : CPH3409 (Nch MOSFET : SANYO), IRLM2502 (Nch MOSFET : IR)

Note : VGS Breakdown Voltage of CPH6315 and CPH3409 is 10V so please be careful with the power supply voltage. For the power supply voltage more than 8V, CPH3308 (Pch MOSFET : SANYO) or CPH3408 (Nch MOSFET : SANYO) which breakdown voltage is 20V are recommended.

L : 22μH (SUMIDA CDRH127 / LD) CIN : 16V, 47μF (NICHICHEMI Tantalum MCE Series)
 CL : 16V, 47μF x 2 (NICHICHEMI Tantalum MCE Series) SD : CMS02 (TOSHIBA, Schottky Barrier Diode)

■ EXTERNAL COMPONENTS

○ COIL

PART NUMBER	MANUFACTURER	L VALUE (μH)	SERIAL RESISTANCE (Ω)	RATED CURRENT (A)	W x L (mm)	H (mm)
CDRH127 / LD-220	SUMIDA	22	36.4 m	4.7	12.3 x 12.3	8

○ INPUT / OUTPUT CAPACITANCE

PART NUMBER	MANUFACTURER	VOLTAGE (V)	CAPACITANCE (μF)	W x L (mm)	H (mm)
16MCE476MD2	NICHICHEMI	16.0	47	4.6 x 5.8	3.2±0.2

○ SCHOTTKY BARRIER DIODE

PART NUMBER	MANUFACTURER	REVERSE CURRENT	FORWARD CURRENT	Vfmax (V)	Irrmax (A)	W x L (mm)	H (mm)
CMS02	TOSHIBA	30	3	0.4 (IF=3A)	0.5m (VR=30V)	2.4 x 4.7	0.98±0.1

○ TRANSISTOR (Pch MOSFET)

PART NUMBER	MANUFACTURER	ABSOLUTE MAX. RATINGS			Rds (ON) MAX.(mΩ)	Ciss typ (pF)	VGS (off) (V)	PKG.
		VDSS (V)	VGSS (V)	ID (A)				
CPH6315	SANYO	- 20	±10	- 3	150 (VDS= - 4.0V)	410 (VDC= - 10V)	- 1.4 (MAX.)	CPH6
CPH3308	SANYO	- 30	±20	- 4	140 (VDS= - 4.0V)	560 (VDC= - 10V)	- 2.4 (MAX.)	CPH3
IRLMS6702	IR	- 20	±12	- 2.3	200 (VDS= - 4.5V)	210 (VDC= - 15V)	- 0.7 (MAX.)	Micro6

○ TRANSISTOR (Nch MOSFET)

PART NUMBER	MANUFACTURER	ABSOLUTE MAX. RATINGS			Rds (ON) MAX.(mΩ)	Ciss typ (pF)	VGS (off) (V)	PKG.
		VDSS (V)	VGSS (V)	ID (A)				
CPH3409	SANYO	30	±10	5	42 (VDS=4.0V)	630 (VDC= 10V)	1.3 (MAX.)	CPH6
CHP3408	SANYO	30	±20	5	68 (VDS=4.0V)	480 (VDC= 10V)	2.4 (MAX.)	CPH3

TEST CIRCUITS

Circuit 1

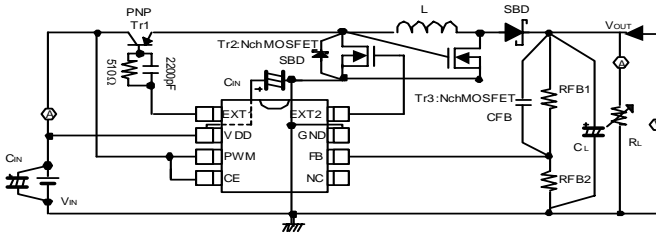

Circuit 2

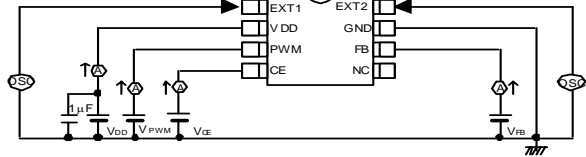

Circuit 3

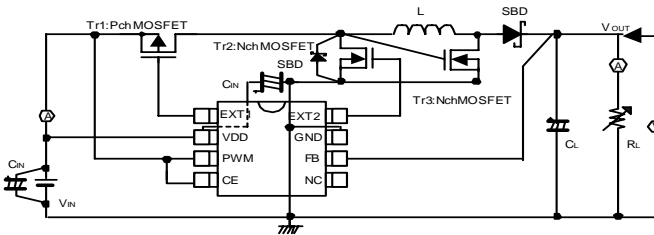

Circuit 4

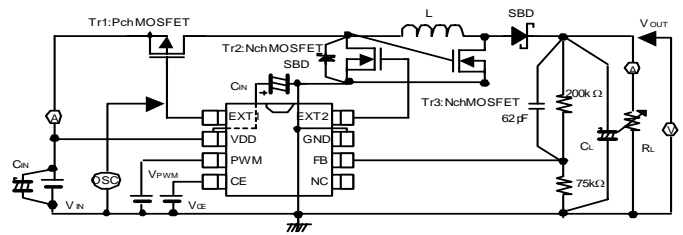

Circuit 5

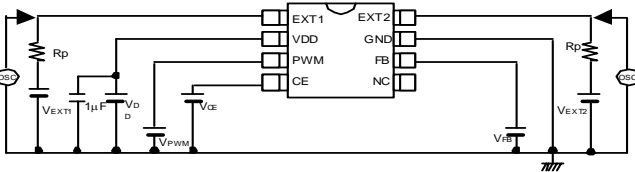

Circuit 1 :

- L: 22µH (SUMIDA CDRH127 / LD)
- SD: CMS02 (TOSHIBA, Schottky Barrier Diode)
- CL: 16MCE476MD2 (NIHONCHEMICON, Tantalum Type)
- CIN: 16MCE476MD2 (NIHONCHEMICON, Tantalum Type)
- PNP Tr 1 : 2SA1213 (TOSHIBA)
- Tr 2 : CPH3409 (SANYO)
- Tr 3 : CPH3409 (SANYO)
- RFB : Please use by the conditions as below.
RFB1 + RFB2 ≤ 1MΩ
RFB1 / RFB2 = (Setting Output Voltage / 0.9) - 1
- CFB : $f_{tcb} = 1 / (2 \times \pi \times CFB \times RFB1) = 1\text{kHz} \sim 50\text{kHz}$ (12kHz usual)

Circuit 3 :

- L: 22µH (SUMIDA CDRH127 / LD)
- SD: CMS02 (TOSHIBA, Schottky Barrier Diode)
- CL: 16MCE476MD2 (NIHONCHEMICON, Tantalum Type)
- CIN: 16MCE476MD2 (NIHONCHEMICON, Tantalum Type)
- Tr 1 : CPH6315 (SANYO)
- Tr 2 : CPH3409 (SANYO)
- Tr 3 : CPH3409 (SANYO)

Circuit 4 :

- L: 22µH (SUMIDA CDRH127 / LD)
- SD: CMS02 (TOSHIBA, Schottky Barrier Diode)
- CL: 16MCE476MD2 (NIHONCHEMICON, Tantalum Type)
- CIN: 16MCE476MD2 (NIHONCHEMICON, Tantalum Type)
- Tr 1 : CPH6315 (SANYO)
- Tr 2 : CPH3409 (SANYO)
- Tr 3 : CPH3409 (SANYO)

■ NOTES ON USE

1. PWM/PFM Automatic Switching

If PWM/PFM automatic switching control is selected and the step-down ratio is high (e.g., from 10 V to 1.0 V), the control mode remains in PFM setting over the whole load range, since the duty ratio under continuous-duty condition is smaller than the PFM duty ratio of the XC9303 series. The output voltage's ripple voltage becomes substantially high under heavy load conditions, with the XC9303 series appearing to be producing an abnormal oscillation. If this operation becomes a concern, set pins PWM1 and PWM2 to High to set the control mode to PWM setting.

2. Ratings

Use the XC9303 series and peripheral components within the limits of their ratings.

3. Notes on How to Select Transistor

Synchronous rectification operation prepares fixed time when switching changes so that the high side PchMOSFET and the low side NchMOSFET do not oscillate simultaneously. Also it is designed to prevent the penetration current when the both MOSFET oscillate at the same time. However, some MOSFET may oscillate simultaneously and worsen efficiency. Please select MOSFET with high V_{th} with small input capacity on high side PchMOSFET and the low side NchMOSFET. (When using with large current, please note that there is a tendency for ON resistance to become large when the input capacity of MOSFET is small and V_{th} is high.)

<The check method of whether selected MOSFET is oscillating simultaneously>

In order to check that MOSFET is not oscillating simultaneously, please observe Lx terminal waveform of coil current at the time of the continuation mode. If the MOSFET parasitism diode waveform on Lx terminal waveform can be formed in the period EXT 1 is 'H' and EXT2 is 'L', it can be thought that MOSFETs are not oscillating simultaneously.

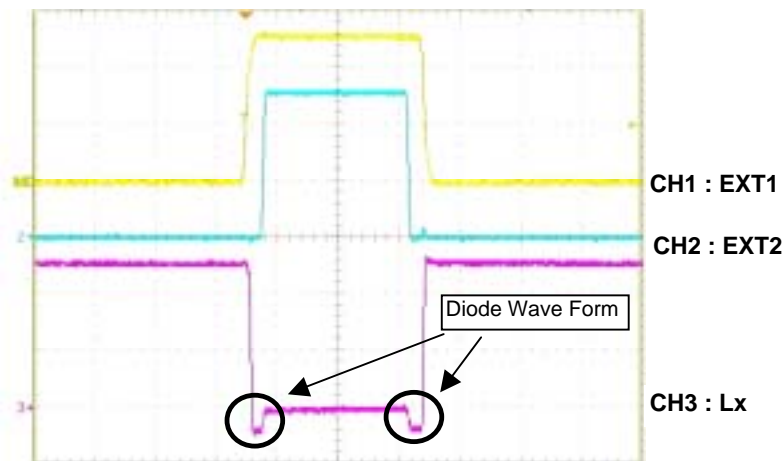

■ TYPICAL APPLICATION CIRCUIT

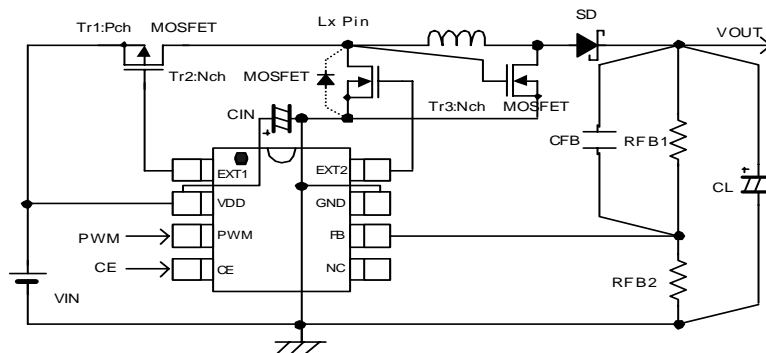

■ TYPICAL PERFORMANCE CHARACTERISTICS

(1) Output Voltage vs. Output Current

FOSC=300kHz, VOUT=3.3V

L=22uH(CDRH127/LD), CL=94uF(Tantalum),SD:CMS02
Tr1:CPH6315, Tr2:CPH3409, Tr3:CPH3409

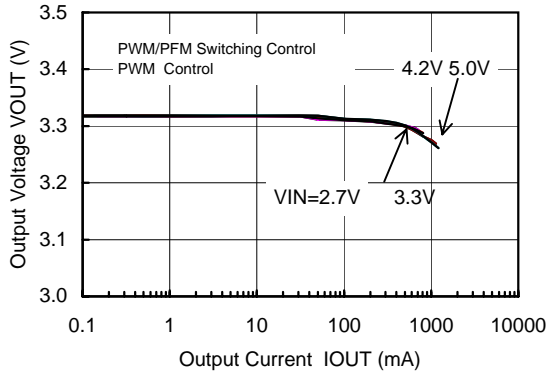

FOSC=300kHz, VOUT=5.0V

L=22uH(CDRH127/LD), CL=94uF(Tantalum),SD:CMS02
Tr1:CPH6315, Tr2:CPH3409, Tr3:CPH3409

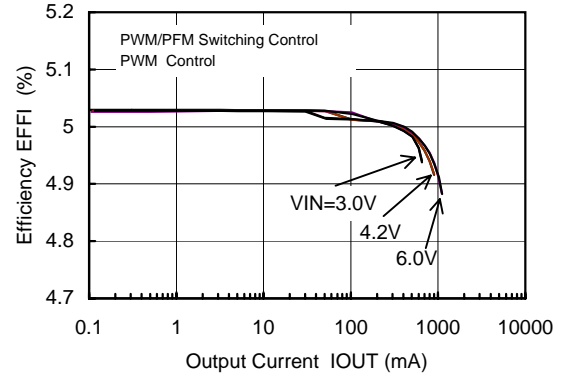

FOSC=300kHz, VOUT=3.3V

L=22uH(CDRH127/LD), CL=94uF(Tantalum),SD:CMS02
Tr1:IRLMS6702, Tr2:IRLMS1902, Tr3:IRLML2502

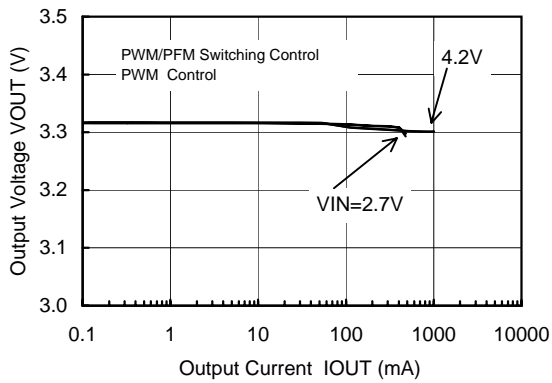

(2) Efficiency vs. Output Current

FOSC=300kHz, VOUT=3.3V

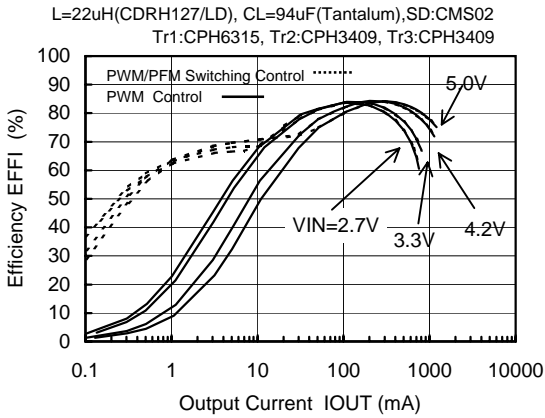

FOSC=300kHz, VOUT=5.0V

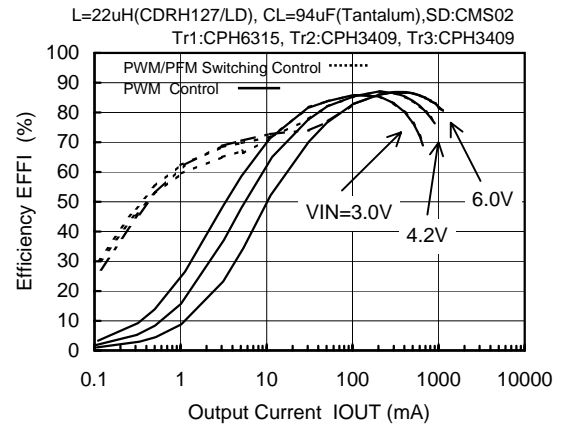

FOSC=300kHz, VOUT=3.3V

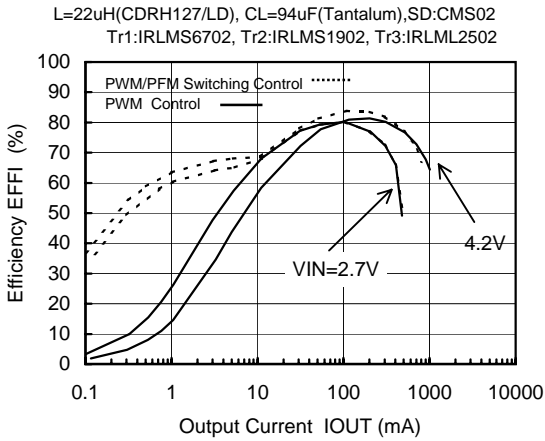

(3) Ripple Voltage vs. Output Current

FOSC=300kHz, VOUT=3.3V

L=22uH(CDRH127/LD), CL=94uF(Tantalum),SD:CMS02
Tr1:CPH6315, Tr2:CPH3409, Tr3:CPH3409

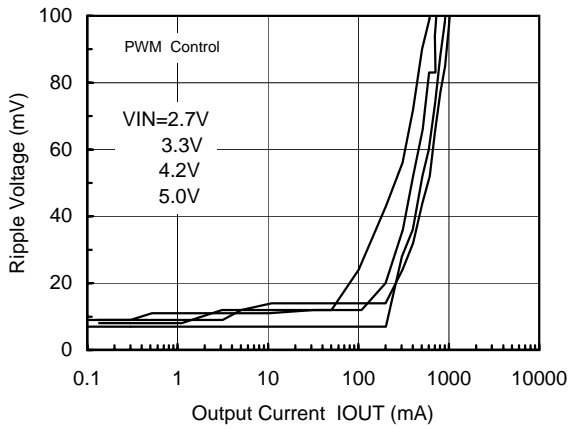

FOSC=300kHz, VOUT=3.3V

L=22uH(CDRH127/LD), CL=94uF(Tantalum),SD:CMS02
Tr1:CPH6315, Tr2:CPH3409, Tr3:CPH3409

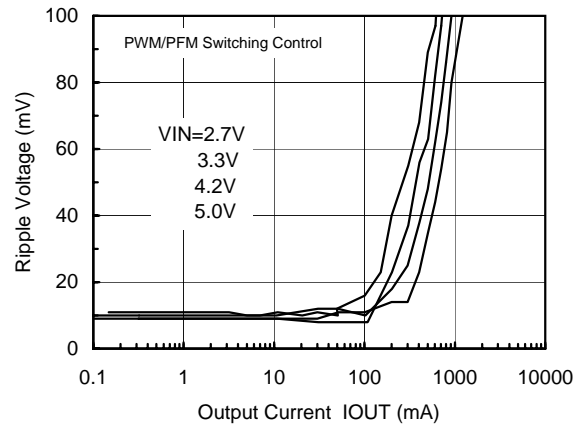

FOSC=300kHz, VOUT=5.0V

L=22uH(CDRH127/LD), CL=94uF(Tantalum),SD:CMS02
Tr1:CPH6315, Tr2:CPH3409, Tr3:CPH3409

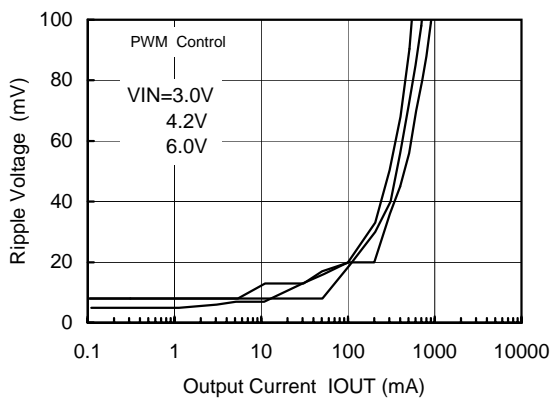

FOSC=300kHz, VOUT=5.0V

L=22uH(CDRH127/LD), CL=94uF(Tantalum),SD:CMS02
Tr1:CPH6315, Tr2:CPH3409, Tr3:CPH3409

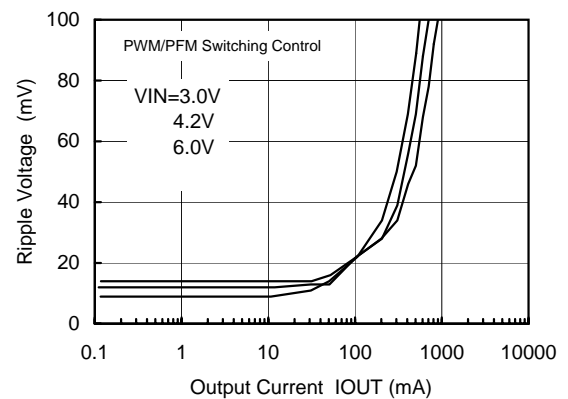

FOSC=300kHz, VOUT=3.3V

L=22uH(CDRH127/LD), CL=94uF(Tantalum),SD:CMS02
Tr1:IRLMS6702, Tr2:IRLMS1902, Tr3:IRLML2502

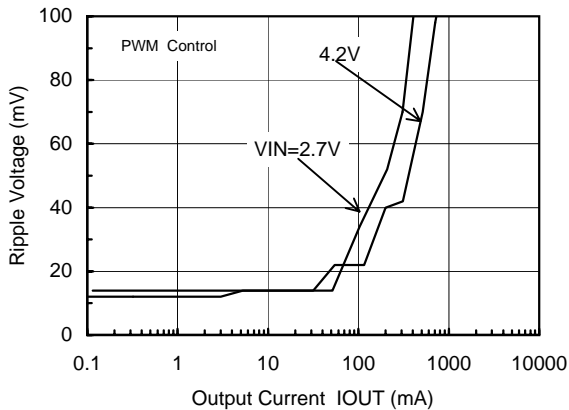

FOSC=300kHz, VOUT=3.3V

L=22uH(CDRH127/LD), CL=94uF(Tantalum),SD:CMS02
Tr1:IRLMS6702, Tr2:IRLMS1902, Tr3:IRLML2502

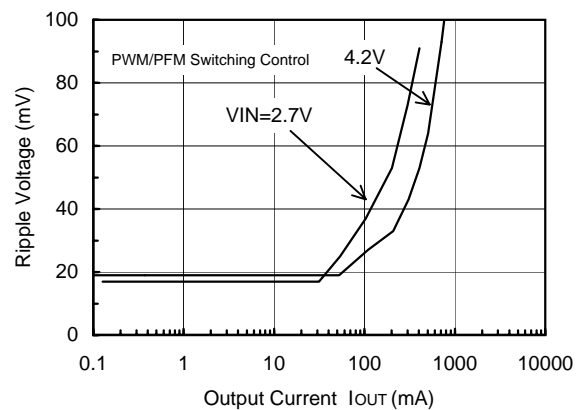

(4) Supply Current 1 vs. Supply Voltage

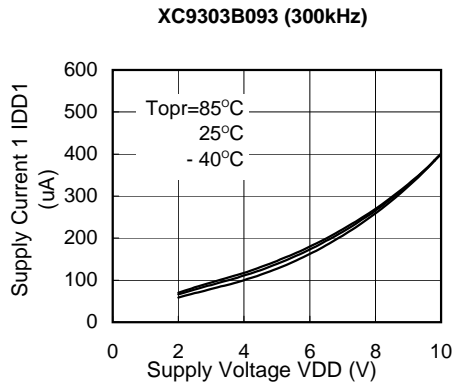

(5) Supply Current 2 vs. Supply Voltage

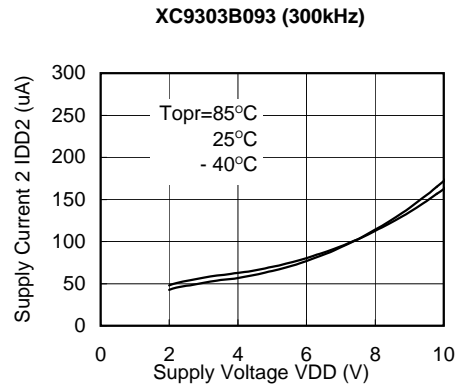

(6) Stand-by Current vs. Supply Voltage

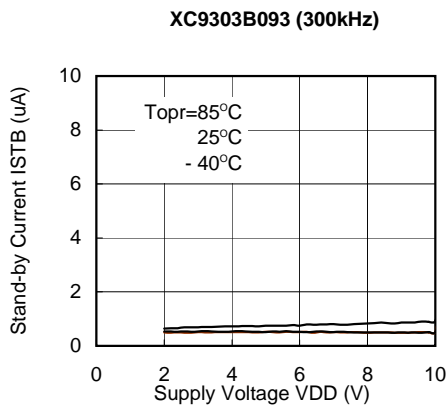

(7) Softstart Time vs. Supply Voltage

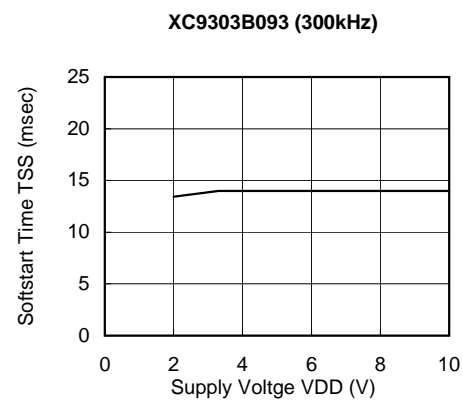

(8) CE 'H' 'L' Voltage vs. Supply Voltage

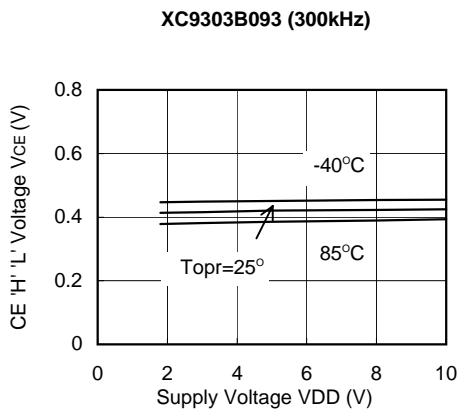

(9) PWM 'H' 'L' Voltage vs. Supply Voltage

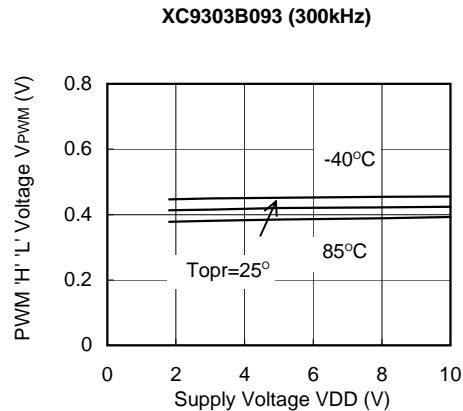

(10) Maximum Duty Ratio vs. Supply Voltage

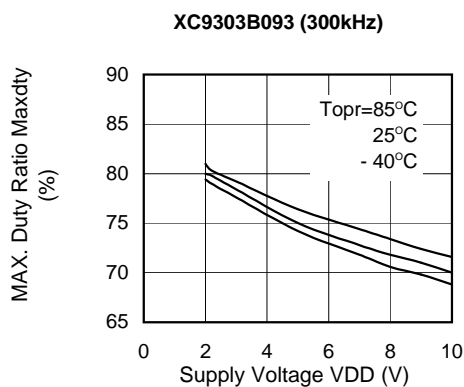

(11) Oscillation Frequency vs. Supply Voltage

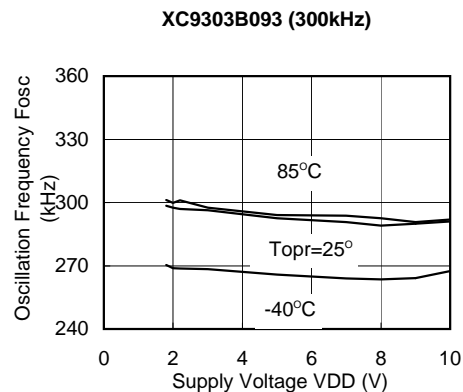

(12) EXT 1 High ON Resistance vs. Supply Voltage

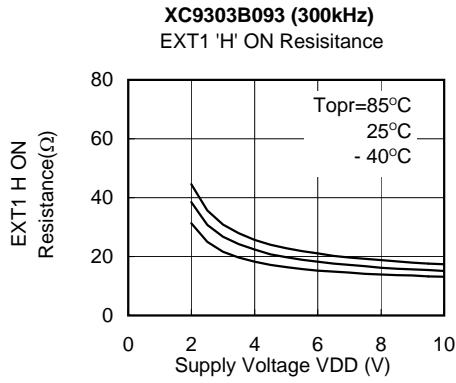

(13) EXT1 Low ON Resistance vs. Supply Voltage

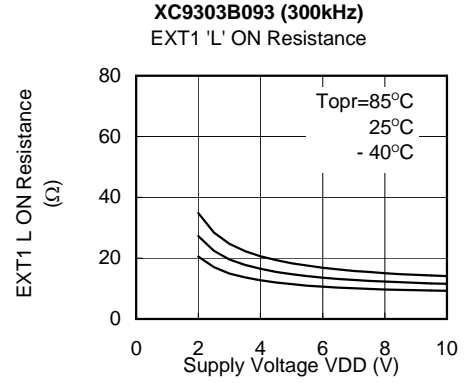

(14) EXT2 High ON Resistance vs. Supply Voltage

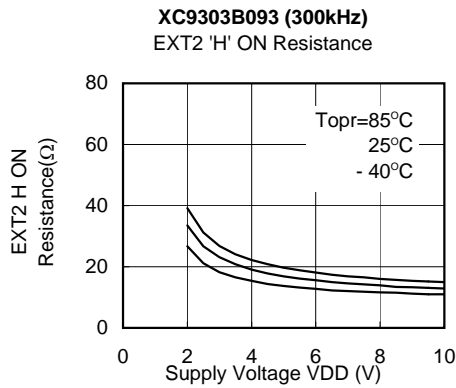

(15) EXT2 Low ON Resistance vs. Supply Voltage

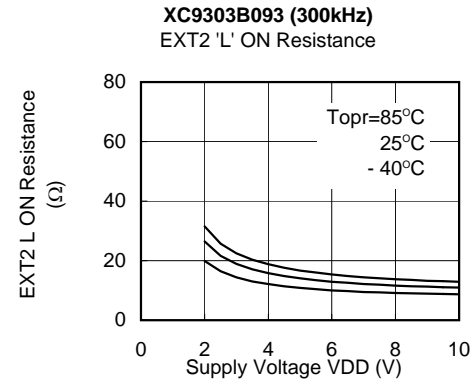

(16) Output Voltage vs. Ambient Temperature 1

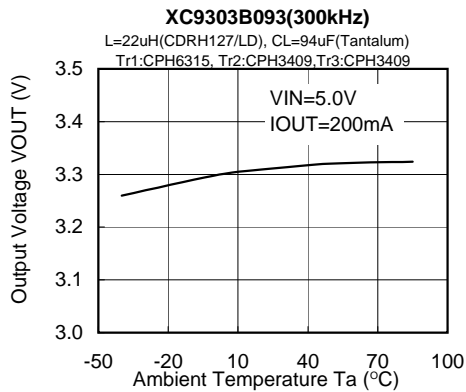

(17) Output Voltage vs. Ambient Temperature 2

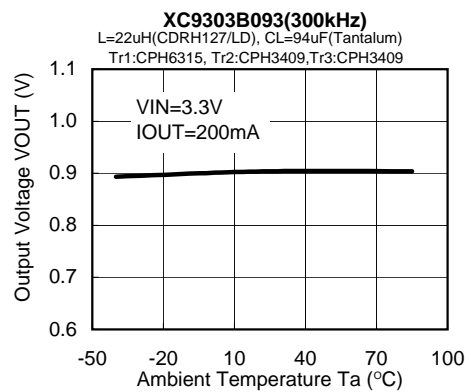

(18) PFM Duty Ratio vs. Supply Voltage

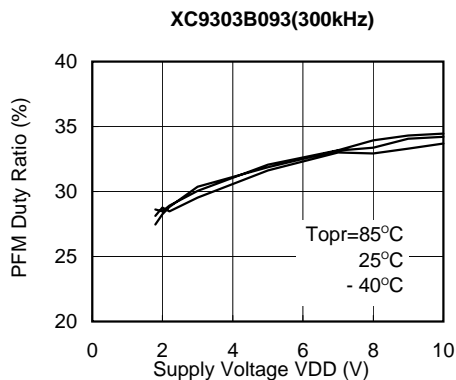

■ LOAD TRANSIENT RESPONSE

< VOUT1, 2 = 3.3 V, VIN = 5.0V IOUT1, 2 = 100 μ A \leftrightarrow 100mA >

○ Synchronous PWM Control

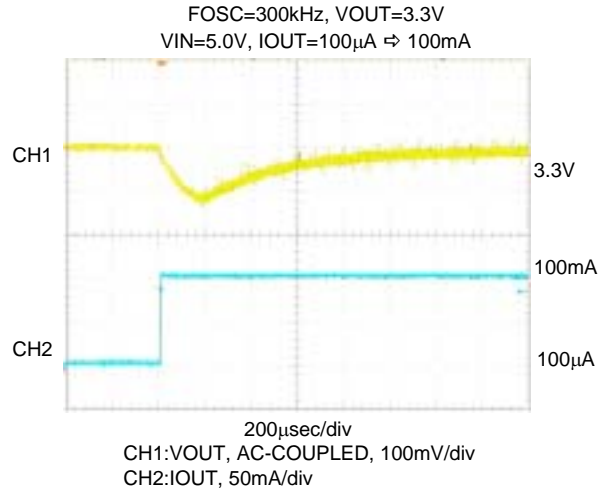
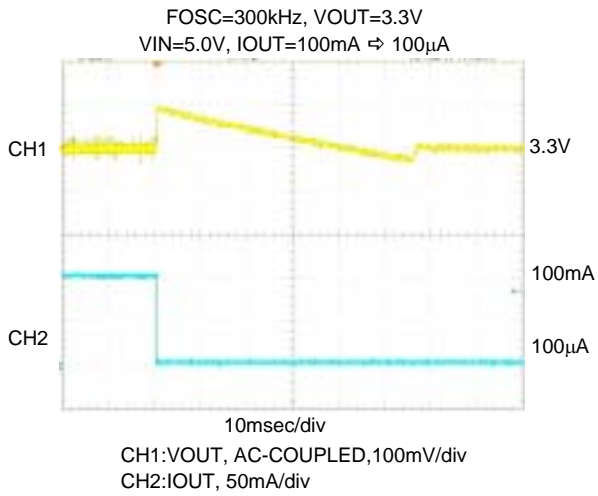

○ Synchronous PWM/PFM Switching Control

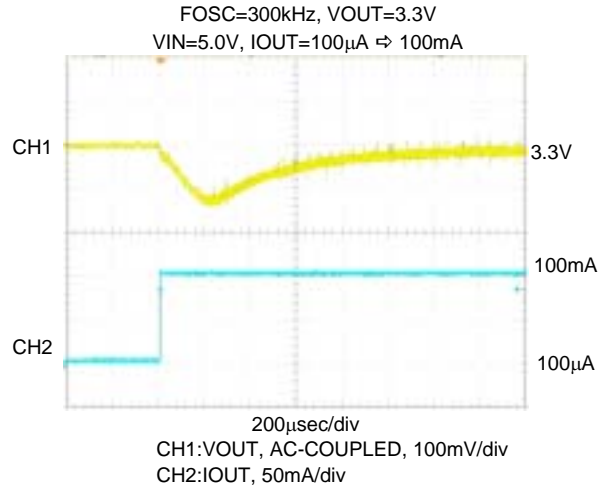
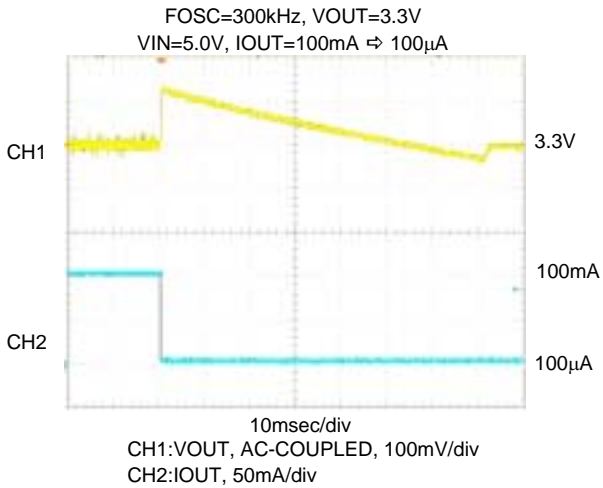

< VOUT1, 2 = 3.3 V, VIN = 5.0V IOUT1, 2 = 100 μ A \leftrightarrow 300mA >

○ Synchronous PWM Control

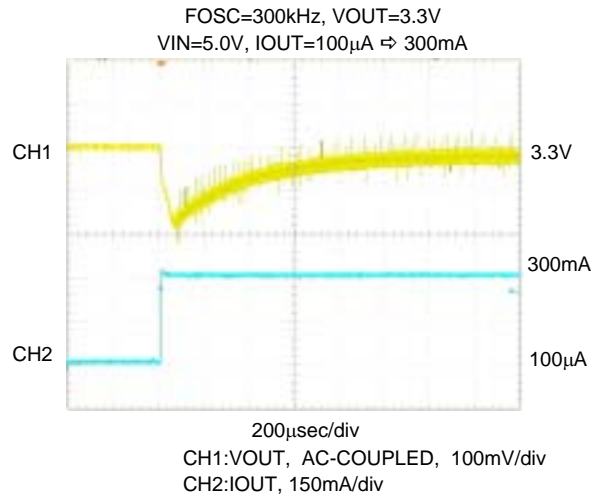
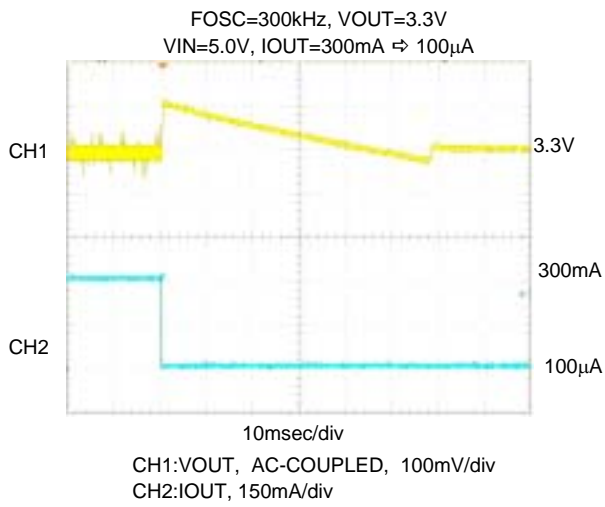

○ Synchronous PWM/PFM Switching Control

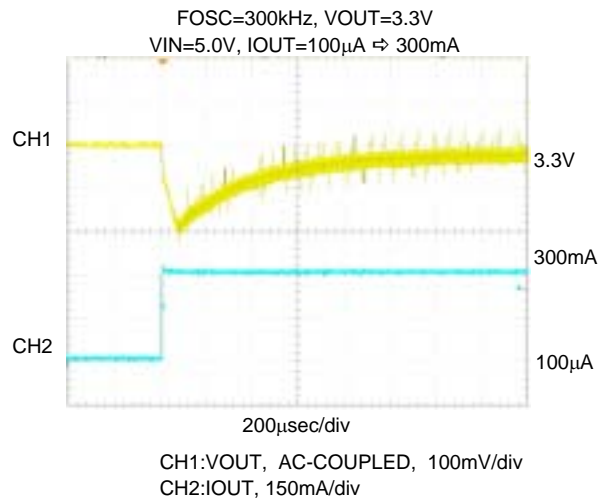
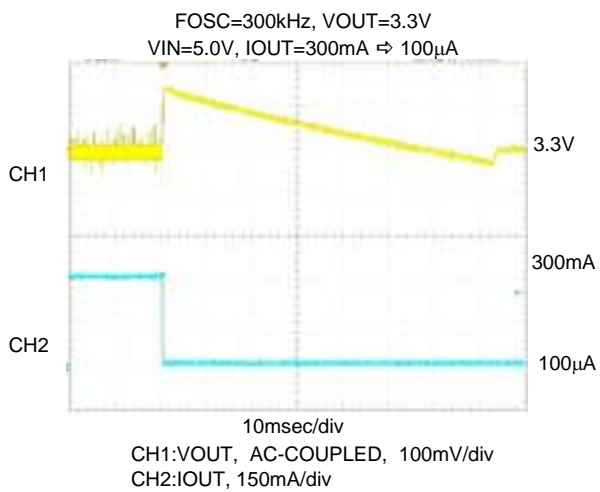

< VOUT1, 2 = 3.3 V, VIN = 2.7V IOUT1, 2 = 100μA ↔ 100mA >

○ Synchronous PWM Control

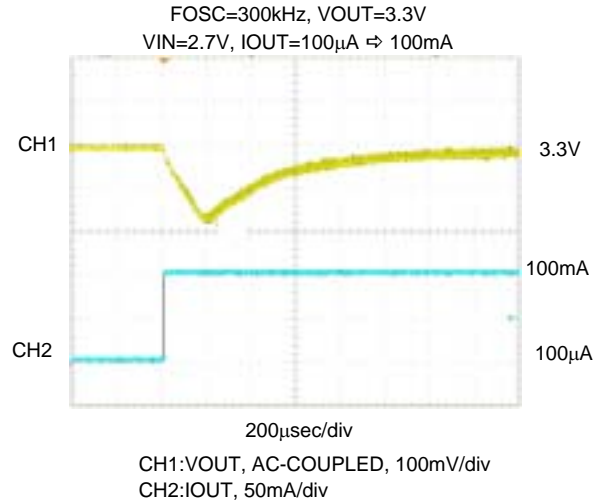
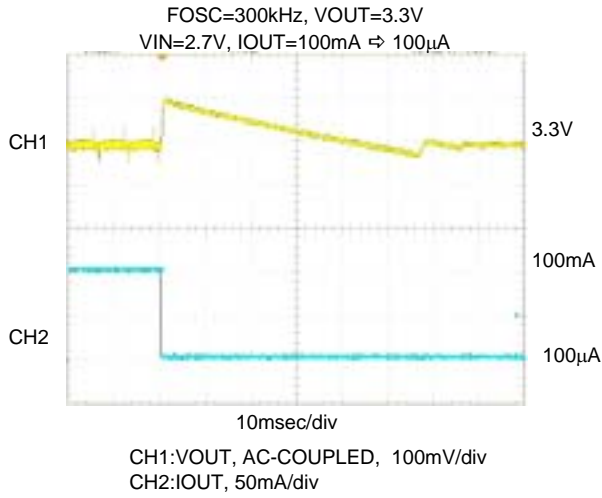

○ Synchronous PWM/PFM Switching Control

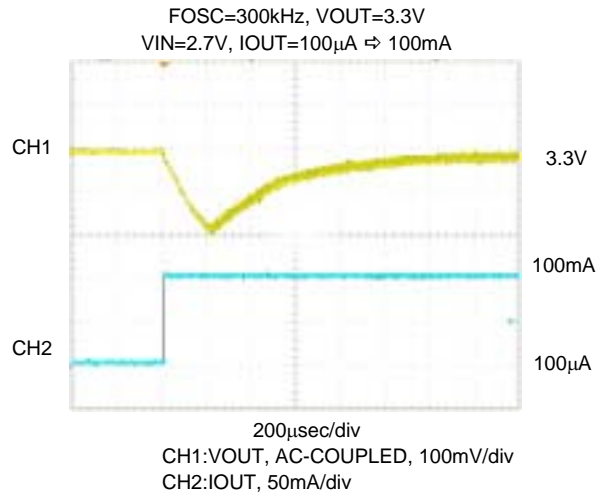
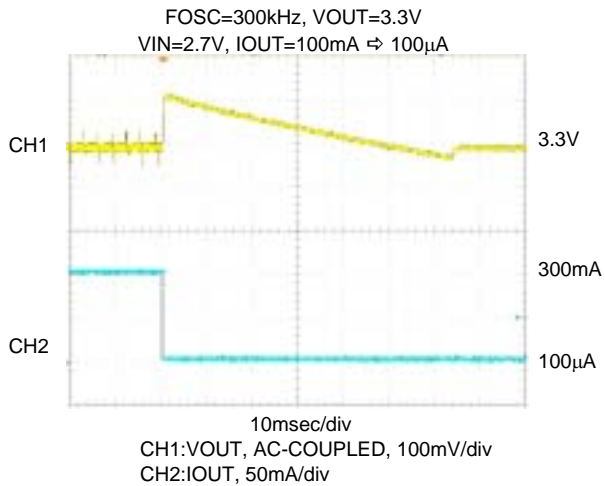

< VOUT1, 2 = 3.3 V, VIN = 2.7V IOUT1, 2 = 100 μ A \leftrightarrow 300mA >

○ Synchronous PWM Control

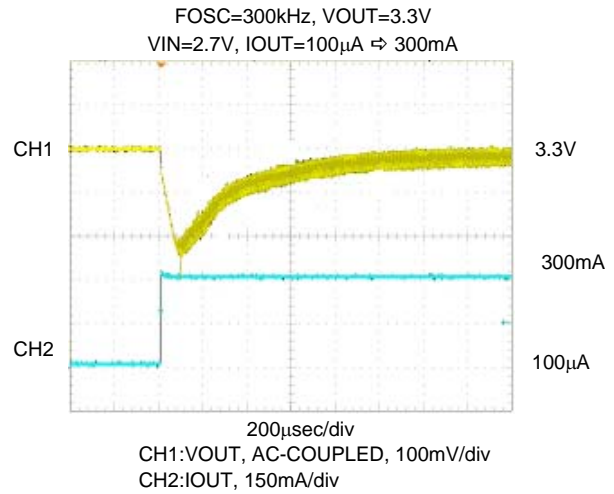
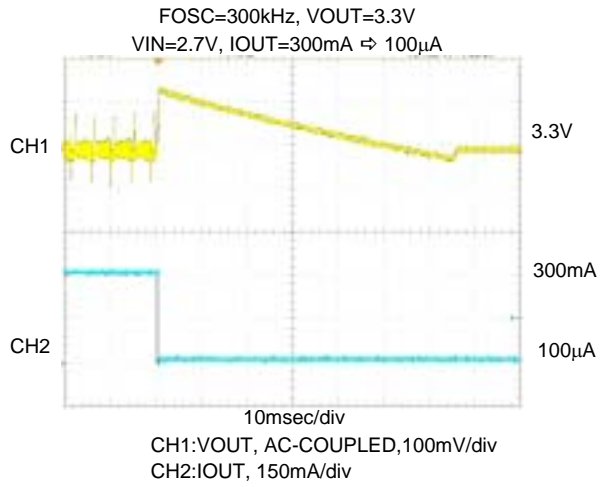

○ Synchronous PWM/PFM Switching Control

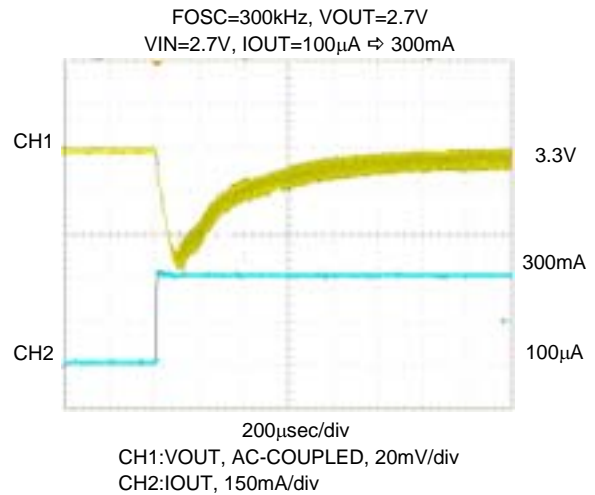
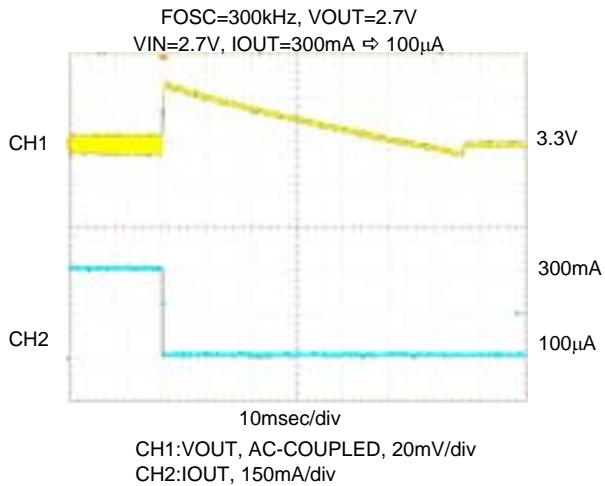

< PWM Control ↔ PWM / PFM Switching Control >

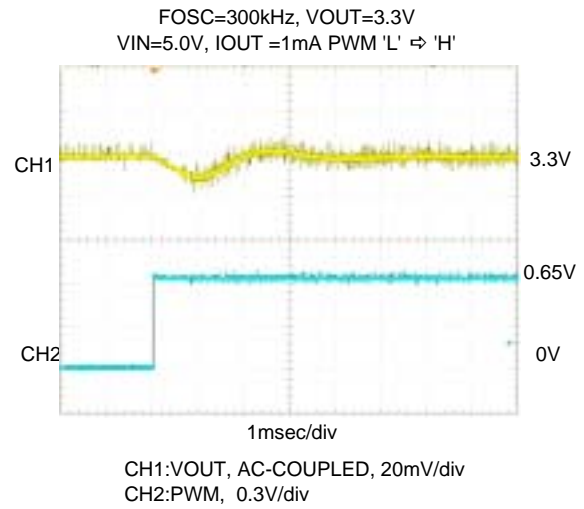
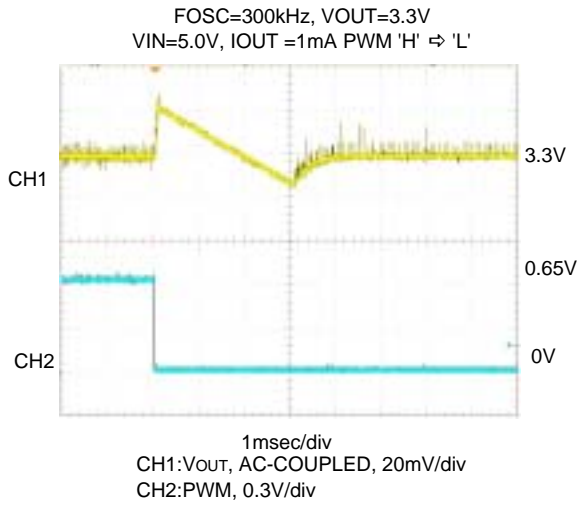

< Softstart Wave Form >

