

C30645E/C30662E Series

InGaAs Avalanche Photodiode

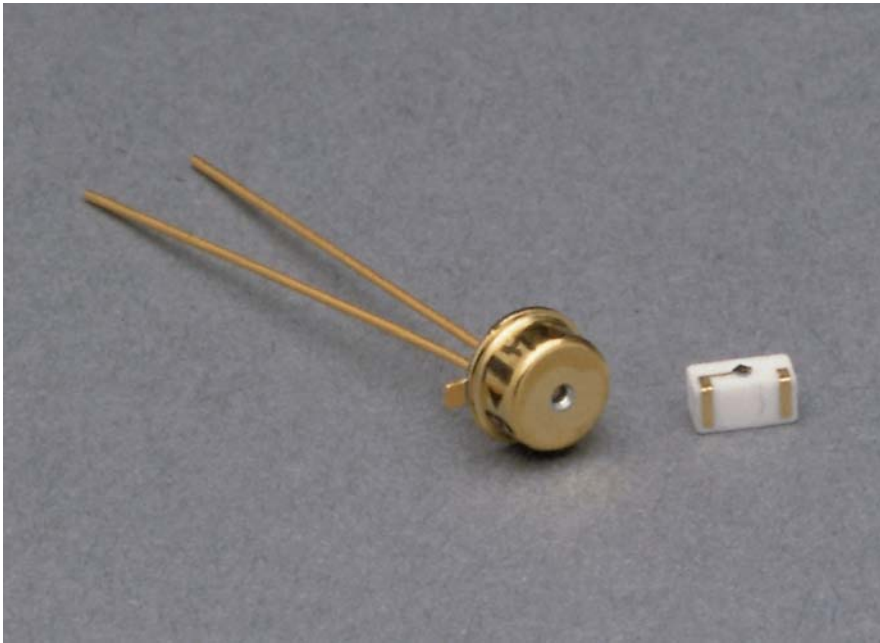

Description

The C30645E/C30662E are high speed, large area InGaAs/InP avalanche photodiodes. These devices provide high Q.E., high responsivity and low noise in the spectral range between 1100nm and 1700nm. They are optimized for use at a wavelength of 1540nm, suitable for use in eye-safe laser range finding systems.

These APDs are supplied in a hermetically sealed TO-18 package or on a ceramic carrier.

Custom packaging is also available. Please contact PerkinElmer Optoelectronics Canada to discuss the packaging in further detail.

Quality & Reliability

PerkinElmer Optoelectronics Canada is committed to supplying the highest quality product to our customer.

We are certified to meet ISO-9001 and we are designed to meet MIL-STD-883 and/or MIL-STD-750 specifications.

All devices undergo extended burn-in and periodic process qualification programs to assure high reliability.

Applications

- ▶ OTDR
- ▶ Eye safe range finding

Features

- ▶ Spectral response (1100 to 1700nm)
- ▶ High responsivity
- ▶ Low dark current and noise
- ▶ Large area



Table 1. Electrical Characteristics at T_A = 22°C

Parameter	C30645E			C30662E			Units
	Min.	Typ.	Max.	Min.	Typ.	Max.	
Diameter		80			200		um
Operating Voltage (Vop)	40		70	40		70	V
Temperature Coefficient of Vr for Constant Gain		0.14	0.20		0.14	0.20	V / deg C
Responsivity (@1550nm)	9.3			9.3			A/W
Dark Current (@M=10)			50			150	nA
Spectral Noise Current (@M=10)			1.0			1.5	pA/rt Hz
Capacitance		1.25			2.5		pF
Bandwidth	1000			200			MHz
Quantum Efficiency (1300-1550nm)	75%			75%			
Maximum Useable Gain (M)	10	20		10	20		

1. A specific voltage, Vop, is supplied with each device. When the photodiode is operated at this voltage (at 22°C), the device will meet the electrical characteristic limits shown above. The voltage value will be within the range of 40 to 70 volts.
2. The voltage dependence of the gain, for gains above 4, is given approximately by the following empirical formula:
M = 50 / (Vb - Vop). Rough approximate of the sensitivity.
3. Gain and quantum efficiency are not directly measurable quantities. The numbers quoted are estimated typical values. Gain, quantum efficiency and responsivity are related by the following: R = ηλM / 1.24 where λ is the wavelength in units of mm, η is the quantum efficiency, M is gain.

4. The detector noise current / Hz^{1/2} is given by the following expression:

$$i_n = (2q (I_s + I_b M^2 F))^{1/2}$$

Where: F = KeffM + (1 - Keff) (2-1/M) and Is and Ib are the unmultiplied and multiplied portions of the dark current, respectively. The total dark current is given by: It = Is + IbM.

However, since both Is and Ib are somewhat voltage dependent, and M is not directly measurable (see Note 3), it is not usually possible to determine both Is and Ib unambiguously. Since system performance depends on noise current and responsivity, these measurable quantities are the ones that have been specified.

5. Most devices can be operated at gains up to about 30 or more, but with values of noise current correspondingly higher, as indicated by the discussion in Note 4 above.

Table 2. Absolute Maximum Rating, Limiting Values

	Standard TO-18 Package	Ceramic Package	Units
Forward Current	5	5	mA
Total Power dissipation	20	20	mW
Operating Temperature	-60 to +125	-60 to +125	°C
Storage Temperature	-20 to +70	-20 to +70	°C
Soldering Temperature (10 seconds)	250	250	°C

Figure 1. Mechanical Characteristics

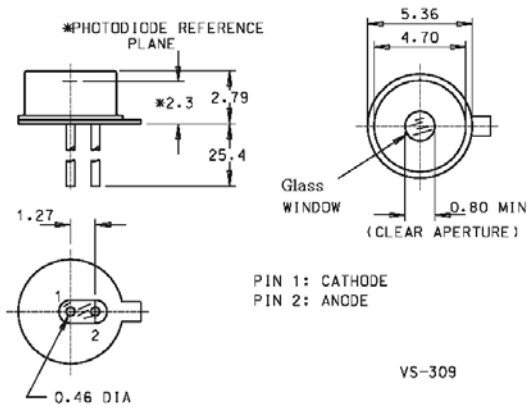

TO – 18 Package

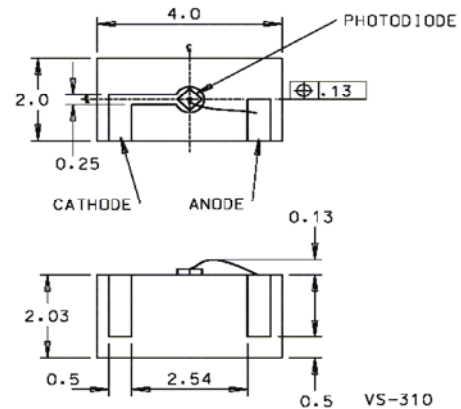

Ceramic Package

Figure 2. Spectral Responsivity Curve

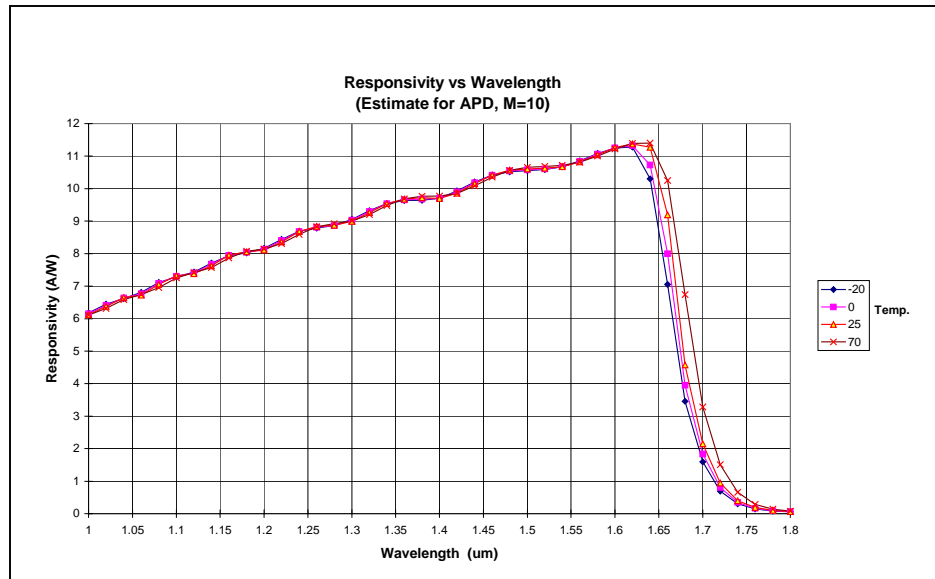
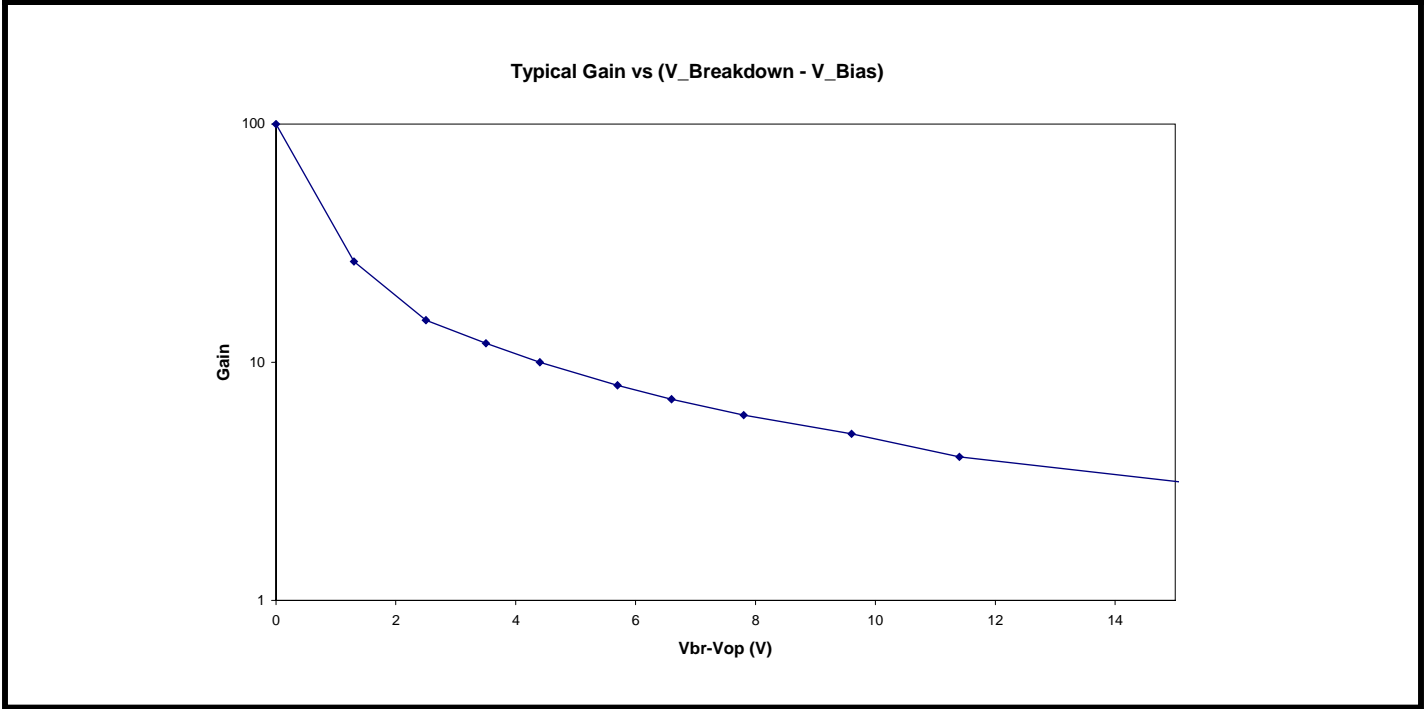

Figure 3. Typical Gain vs Bias



Figure 4. Typical Gain vs (V breakdown - V bias)



Ordering Information

For more information e-mail us at opto@perkinelmer.com or visit our website at www.optoelectronics.perkinelmer.com.

All values are nominal; specifications subject to change without notice.

PerkinElmer Canada Inc.
16800 Trans-Canada Highway
Kirkland, Quebec H9H 5G7
Canada
Phone: (514) 693-2200
Fax: (514) 693-2210

PerkinElmer GmbH & Co. KG
Wenzel-Jaksch-Str.31
65199 Wiesbaden
Phone: +49 611 492 247
Fax: +49 611 492 170

PerkinElmer Singapore Pte Ltd.
47 Ayer Rajah Crescent #06-12
Singapore 139947
Phone: +65 6775 2022
Fax: +65 6775 1008

Optoelectronics
Headquarters
44370 Christy Street
Fremont, CA 94538-
3180
Phone: (510) 979-5600
(800) 775-6786
Fax: (510) 687-1140

