

Description

The CXP750000 is a CMOS 8-bit single chip micro-computer of piggyback/evaluator combined type, which is developed for evaluating the function of the CXP750096/750010.

Note that the CXP750000 corresponds to the custom font.

Features

- A wide instruction set (211 instructions) which covers various types of data
 - 16-bit operation/multiplication and division/ Boolean bit operation instructions
- Minimum instruction cycle
 - 167ns at 24MHz operation
 - 250ns at 16MHz operation
 - 122µs at 32kHz operation
- Applicable EPROM CXP27C702K (Maximum 120K bytes are available.)
- Incorporated RAM 2496 bytes (Excludes VRAM for on-screen display)
- EPROM for custom font 57K bytes
- Peripheral functions
 - A/D converter 8 bits, 6 channels, successive approximation method (Conversion time of 3.25µs at 16MHz)
 - Serial interface 8-bit clock sync type, 1 channel
 - Timer 8-bit timer
8-bit timer/counter
19-bit time-base timer
32kHz timer/counter
 - On-screen display (OSD) 24 × 32 dots, 512 character types, 15 character colors, 32 characters × 2 lines
frame background 8 colors/half blanking
background on full screen 15 colors/half blanking
edging/shadowing/rounding for every line
background with shadow for every character, double scanning
sprite OSD; 24 × 32 dots, 1 screen, 8 colors for every dot
 - I²C bus interface
 - PWM output 8 bits, 8 channels
14 bits, 1 channel
 - Remote control unit receive circuit 8-bit pulse measurement counter, 6-stage FIFO
 - HSYNC counter 2 channels
 - Watchdog timer
- Interruption 13 factors, 13 vectors, multi-interruption possible
- Standby mode Sleep
- Package CXP750000 64-pin ceramic PQFP/PSDIP (Supports custom font)

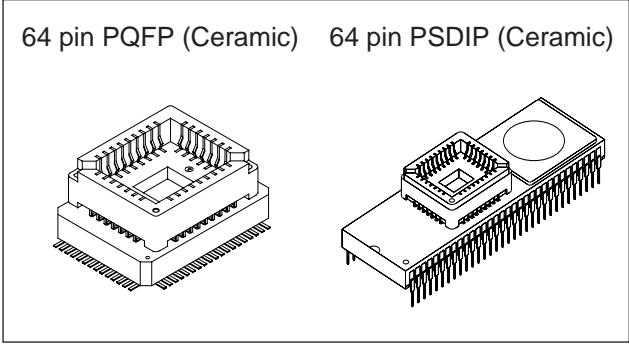

Structure
Silicon gate CMOS IC

Note) Mask option depends on the type of the CXP750000. Refer to the Product List for details.

Purchase of Sony's I²C components conveys a licence under the Philips I²C Patent Rights to use these components in an I²C system, provided that the system conforms to the I²C Standard Specifications as defined by Philips.

Sony reserves the right to change products and specifications without prior notice. This information does not convey any license by any implication or otherwise under any patents or other right. Application circuits shown, if any, are typical examples illustrating the operation of the devices. Sony cannot assume responsibility for any problems arising out of the use of these circuits.

CXP750000

Pin Assignment in Evaluator Mode (Top View)

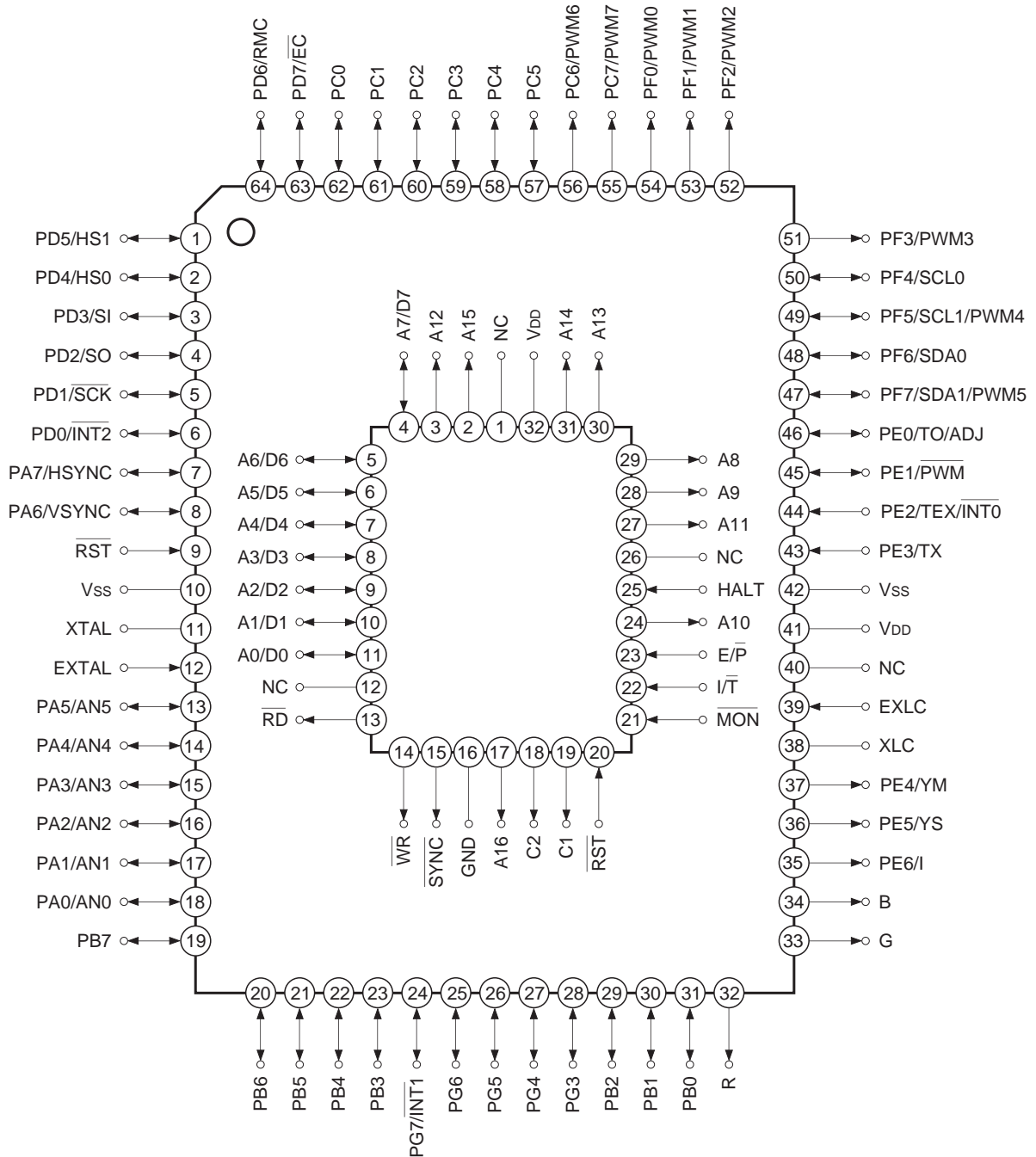

- Note)** 1. NC (Pin 40) is left open.
 2. Vss (Pins 10 and 42) are both connected to GND.

CXP750000

Pin Assignment in Piggyback Mode (Top View)

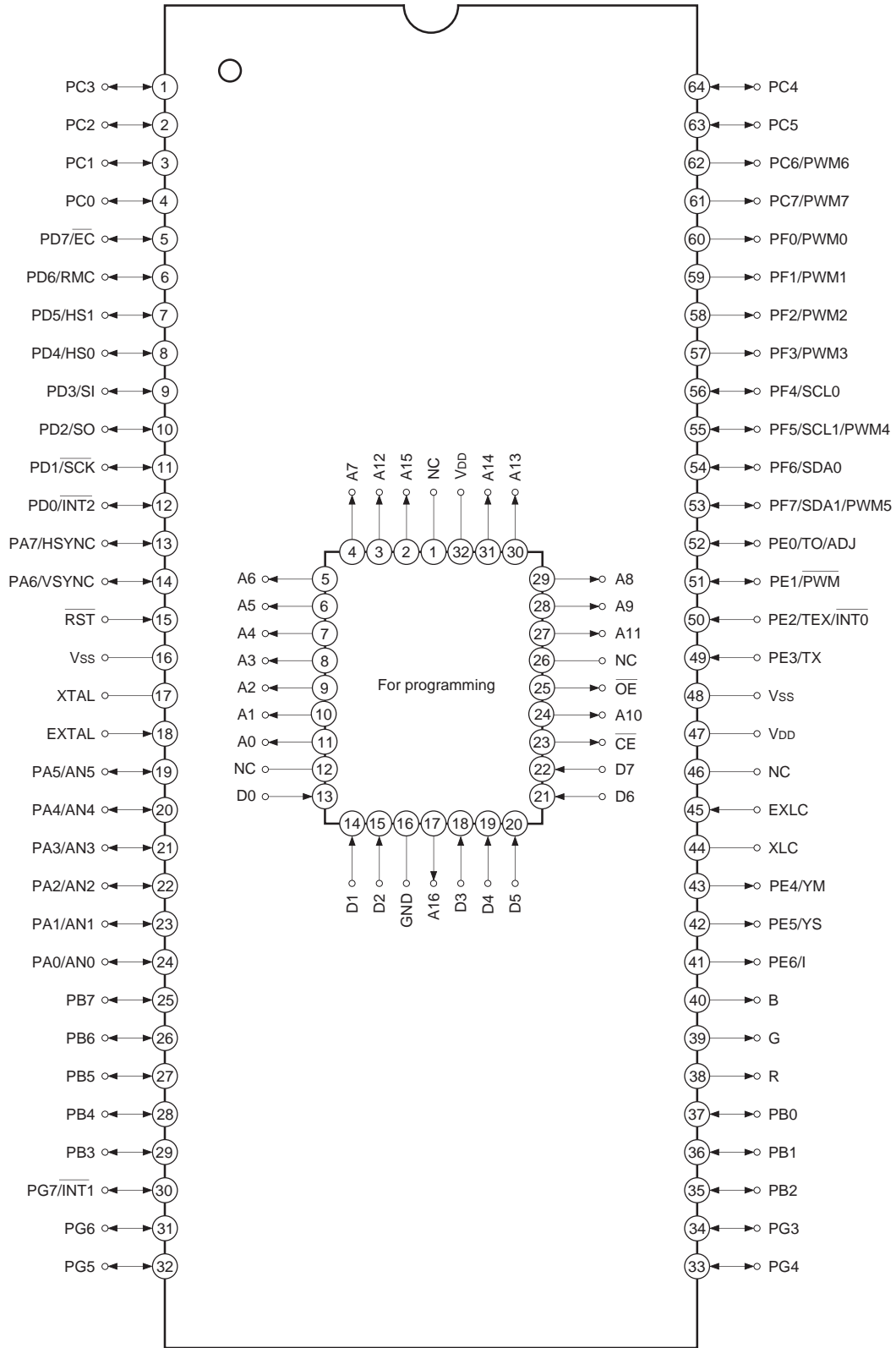

- Note)** 1. NC (Pin 46) is left open.
 2. Vss (Pins 16 and 48) are both connected to GND.

CXP750000

Pin Assignment in Evaluator Mode (Top View)

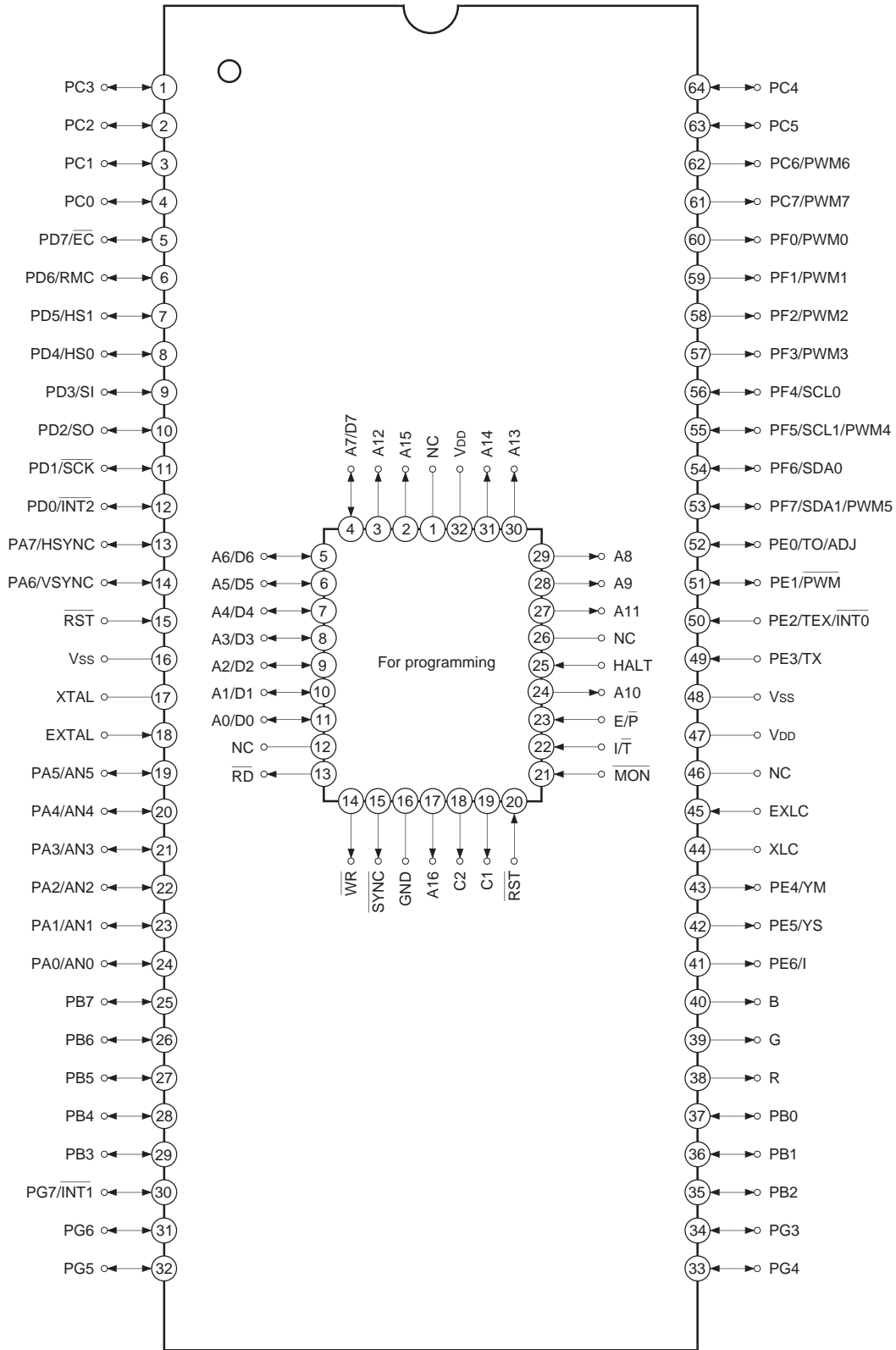

- Note)**
1. NC (Pin 46) is left open.
 2. Vss (Pins 16 and 48) are both connected to GND.

EPROM Read Timing

($T_a = -20$ to $+75^\circ\text{C}$, $V_{DD} = 4.5$ to 5.5V , $V_{SS} = 0\text{V}$)

Item	Symbol	Pins	Min.	Max.	Unit
Address → data input delay time	t_{ACC}	A0 to A16 D0 to D7		75	ns
Address → data hold time	t_{IH}	A0 to A16 D0 to D7	0		ns

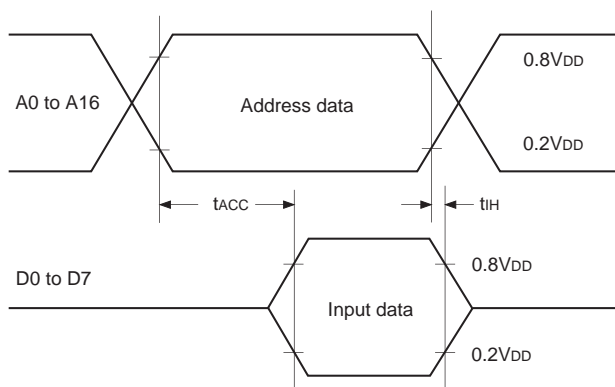

Product List

Optional item	Products			
	Mask ROM		Piggy/evaluation chip	
	CXP750096	CXP750010	CXP750000-U01Q	CXP750000-U01S
Package	64-pin plastic SDIP/QFP		64-pin ceramic PQFP	64-pin ceramic PSDIP
ROM capacity	96K bytes	120K bytes	EPROM 120K bytes	
Reset pin pull-up resisto	Existent/Non-existent		Existent	
Font data	User data		EPROM 57K bytes	

CXP750000

Piggyback mode and evaluator mode can be switched as shown below.

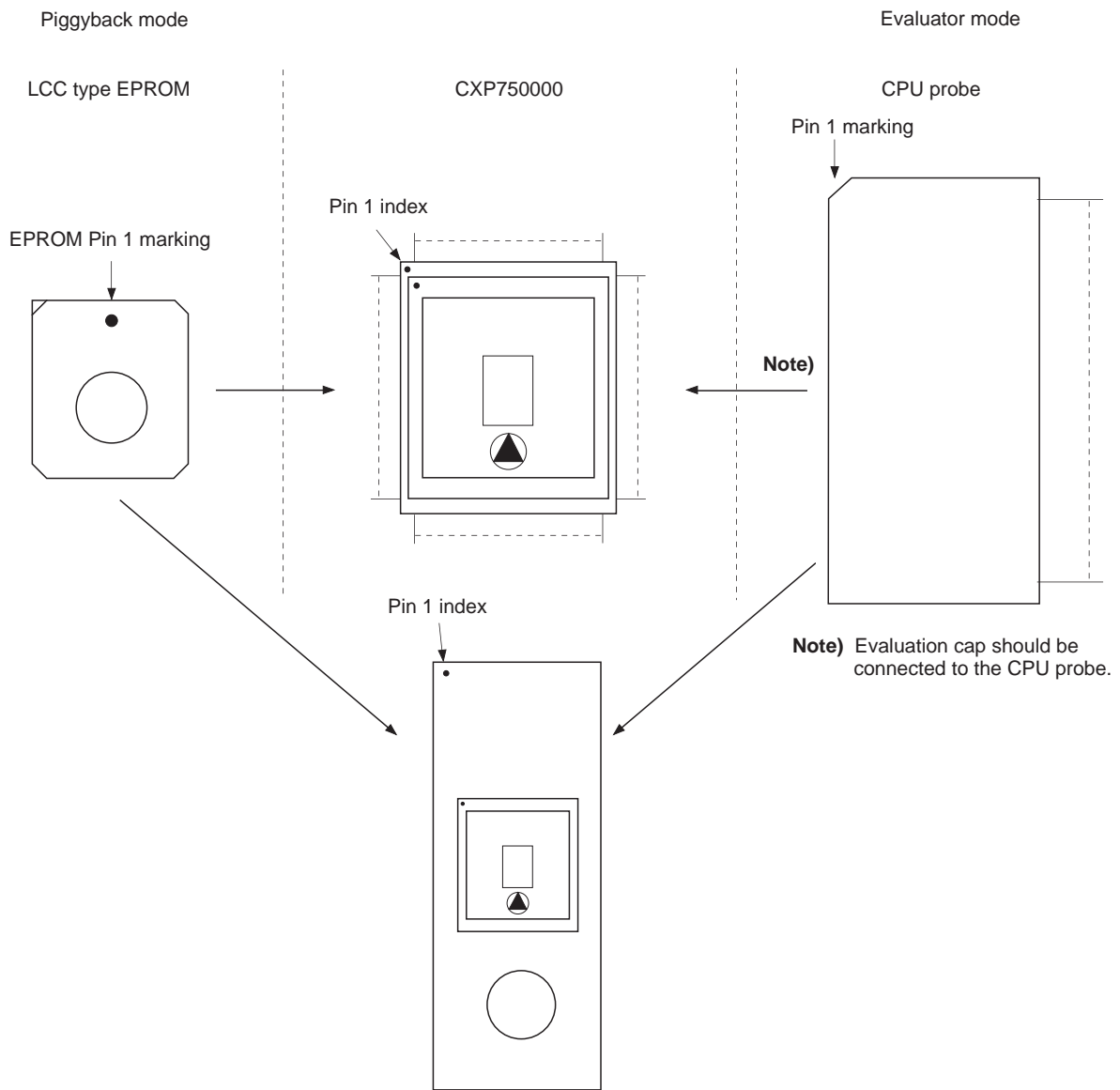

Piggy/Evaluation Chip Corresponds to Custom Font

The CXP750000 is a piggy/evaluation chip which corresponds to custom font. This incorporates EPROM of OSD font data block. This IC is shipped in blank status, and write to EPROM using exclusive write adaptor. Use exclusive font editor (SFE700II) as for generating font data.

Write mode	Intel method
Write voltage	12.75V
Write pulse width	100µs
Write ROM type	27C020
Starting address for write	20000h
Ending address for write	38BFFh
Write adaptor*1	SDIP: SEK7500P10-64S (Upper board) QFP: SEK750000-64Q (Upper board) Lower board: SEK-32DP-DWN2

*1 SUNHAYATO Corp. made

OSD Font Data Block Memory Map

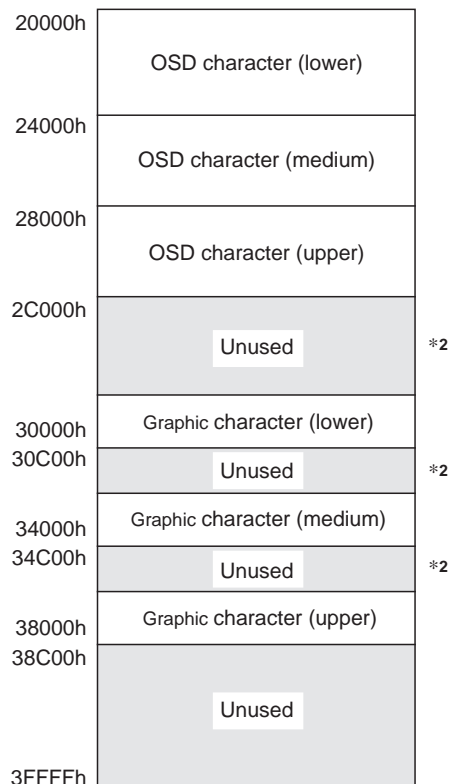

*2 Fill up ROM writer memory with FFh.

Package Outline Unit: mm

64PIN PQFP (CERAMIC)

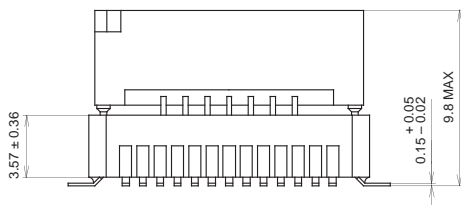
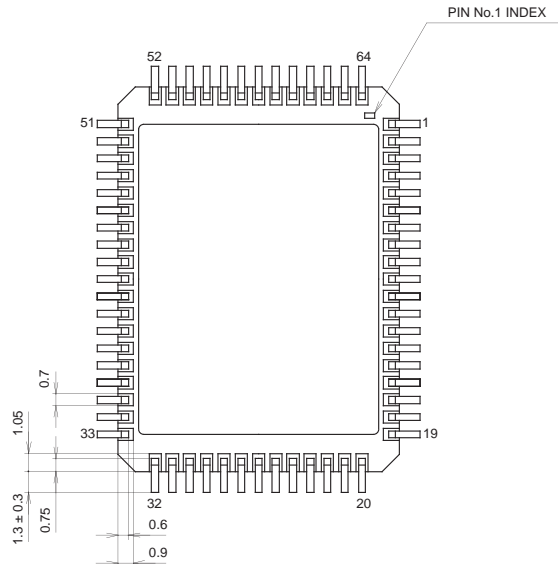
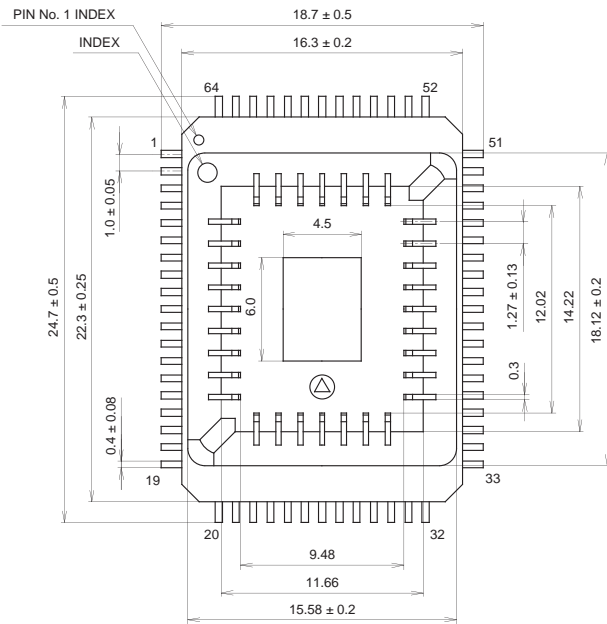

PACKAGE STRUCTURE

SONY CODE	PQFP-64C-L02
EIAJ CODE	AQFP064-C-0000-B
JEDEC CODE	—

PACKAGE MATERIAL	CERAMIC
LEAD TREATMENT	GOLD PLATING
LEAD MATERIAL	42 ALLOY
PACKAGE WEIGHT	5.2g

Package Outline

Unit: mm

64PIN PSDIP(CERAMIC)

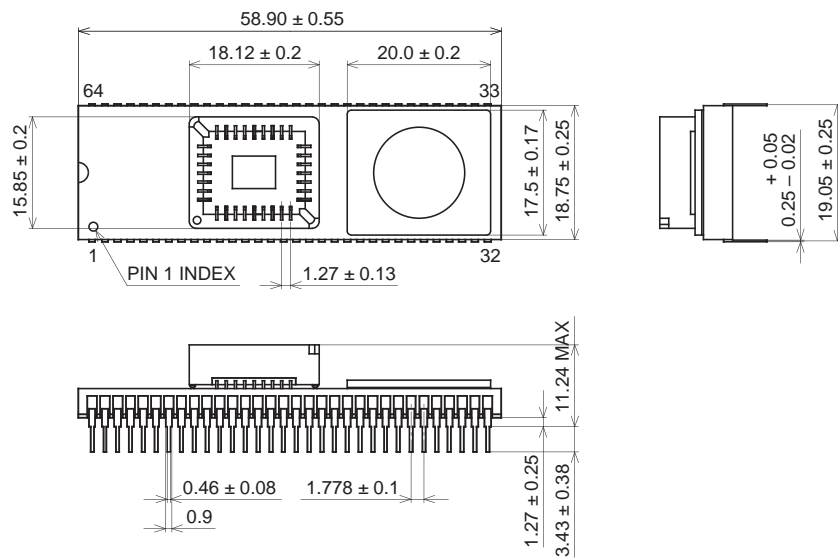

PACKAGE STRUCTURE

SONY CODE	PSDIP-64C-03
EIAJ CODE	ADIP064-C-0750
JEDEC CODE	_____

PACKAGE MATERIAL	CERAMIC
LEAD TREATMENT	GOLD PLATING
LEAD MATERIAL	42 ALLOY
PACKAGE MASS	19.2g