

INTRODUCTION

The KA2272D is a monolithic integrated circuit for the FM noise canceller used in car stereos. It is used in combination with a PLL FM multiplex demodulator (such as the KA2266) with a pilot signal canceller.

FEATURES

- Operation voltage range: $V_{CC} = 8V \sim 15V$
- Low quiescent circuit current
- Low distortion: THD = 0.02% at $V_I = 300mV$
- Pilot signal compensation
- Built-in monostable multivibrator.
- Variable input type noise AGC system.

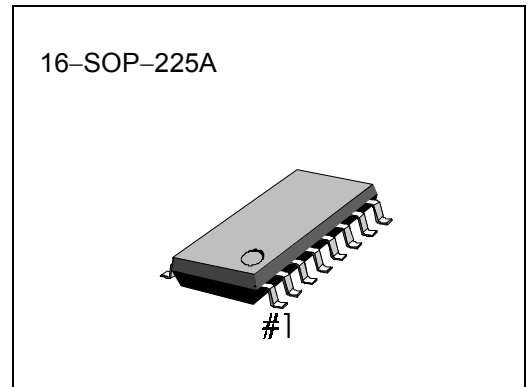

ORDERING INFORMATION

Device	Package	Operating Temperature
KA2272D	16-SOP-225A	-20°C ~ +75°C

BLOCK DIAGRAM

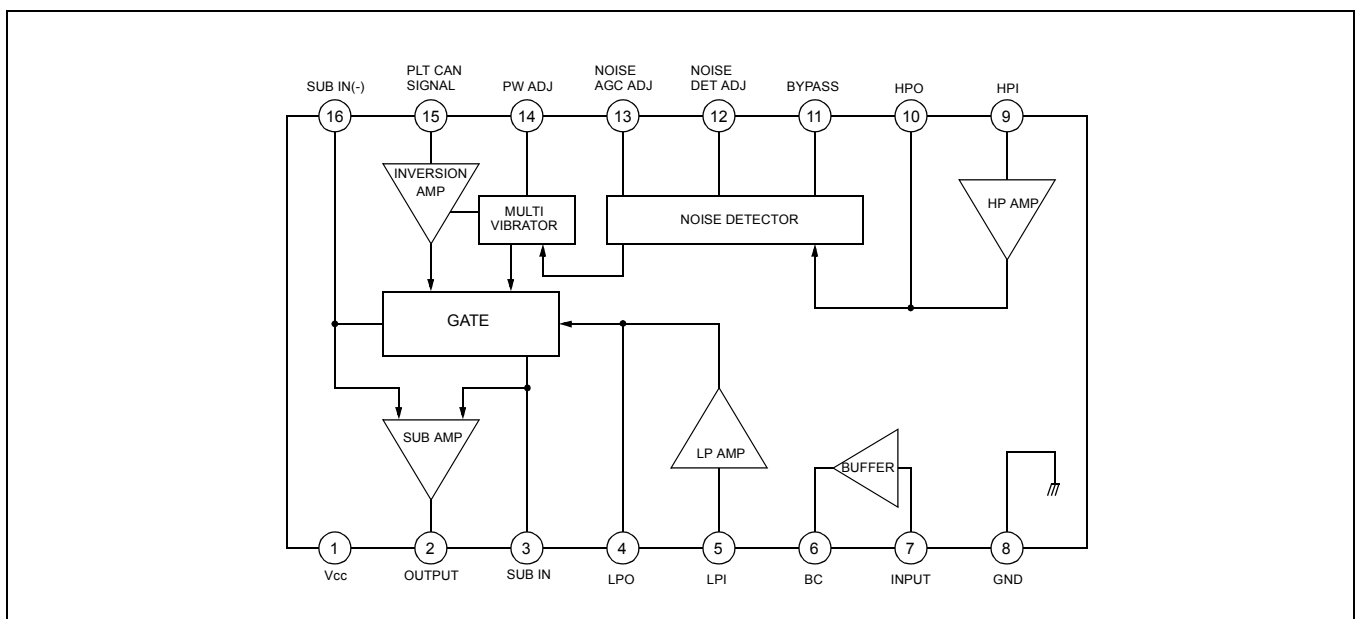

Figure 1.

ABSOLUTE MAXIMUM RATINGS (Ta = 25°C)

Characteristic	Symbol	Value	Unit
Supply Voltage	V _{CC}	16	V
Power Dissipation	PD	300	Min
Operating Temperature	T _{OPR}	-20 ~ + 75	°C
Storage Temperature	T _{STG}	-40 ~ + 125	°C

ELECTRICAL CHARACTERISTICS(Ta = 25°C, V_{CC} = 12V, 300 mV, f = 1kHz, unless otherwise specified)

Characteristic	Symbol	Test Conditions		Min.	Typ.	Max.	Unit
		Input Pin	Output Pin				
Quiescent Circuit Current	I _{CCQ}	–	–	–	16	25	mA
Voltage Gain	G _V	V ₇ = 300 mV, f = 1kHz	Output	-0.2	0.8	1.8	dB
Output Voltage	V _O	V ₇ = variable, f = 1kHz	Output THD = 1%	1.3	–	–	V
Total Harmonic Distortion	THD	V ₇ = 300mV, f = 1kHz	Output		0.01	0.03	K%
Input Resistance	R _I	V ₇ = 300mV, f = 1kHz	–	36	51	67	dB
Low pass AMP Gain	G _{V(LP)}	V ₅ = 300mV, f = 1kHz	V ₄	0	0.83	1.58	dB
High pass AMP Gain	A _{VH}	V ₉ = 100mV f = 200kHz	V ₁₀	1.58	2.92	4.35	V
Inverted Amp Distortion	THD	f = 19kHz	Output	300	–	0.1	%
Inverted Amp Dynamic Range	V _O	V ₁₅ = 100mV f = 19kHz	Output THD = 1%	–	–	–	mV
Inverted Amp Gain	G _V	V ₁₅ = 100mV f = 19kHz	Output	0	2.28	4.08	dB
Output Noise Voltage	V _{NO}	Bypass V ₇ V ₁₅ to GND	Output, 100 kHz LPF	–	30	60	μV
Gate Time	t _G	V _O = 100mV _{p-p} , 1μs, f = 1kHz	Output	13	21	30	μsec
Noise Sensitivity	SN	V ₇ , 1μs, f = 1kHz	Output	–	–	30	mV _{p-0}

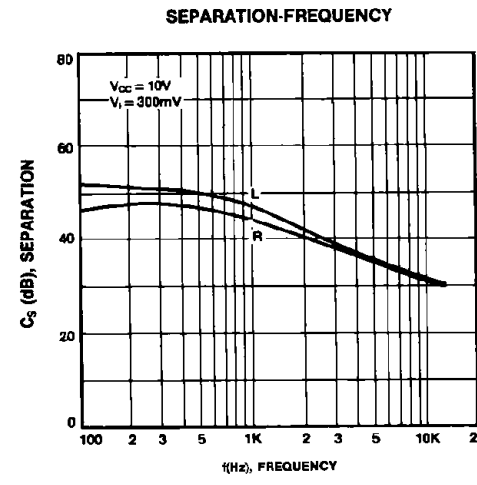
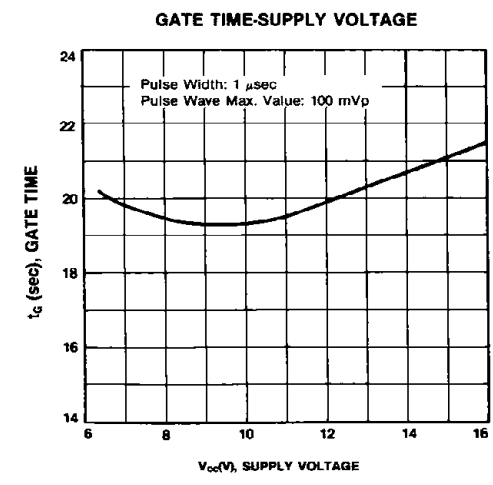
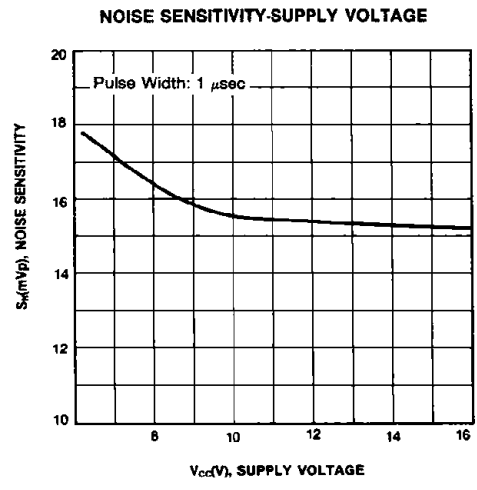
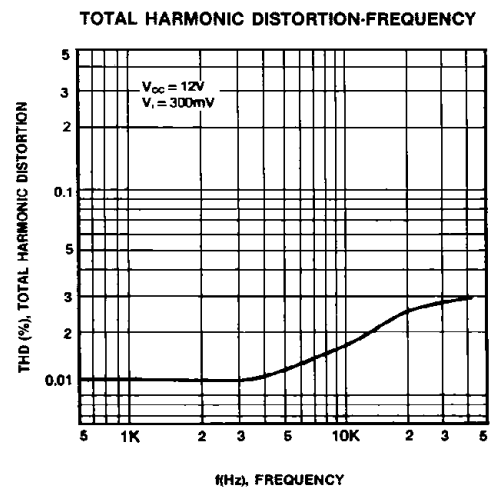
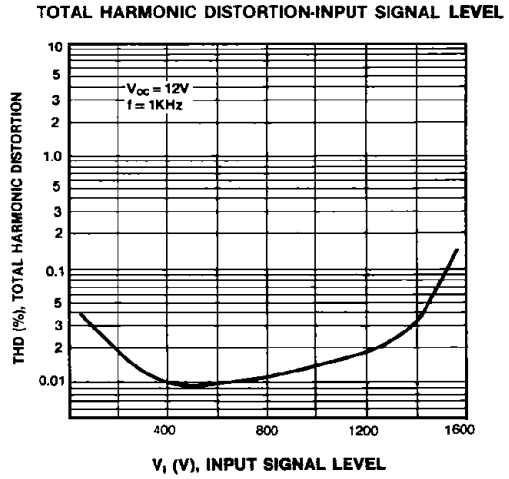
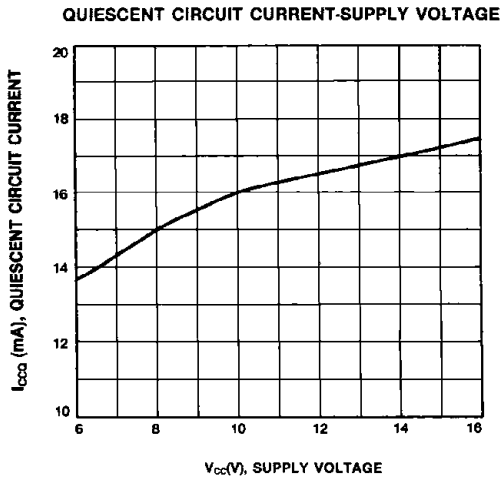

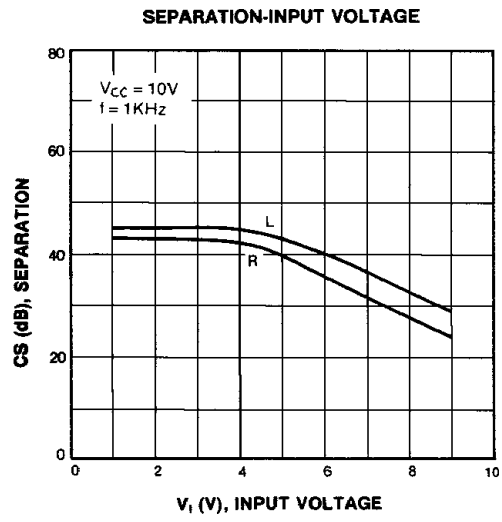

APPLICATION CIRCUIT

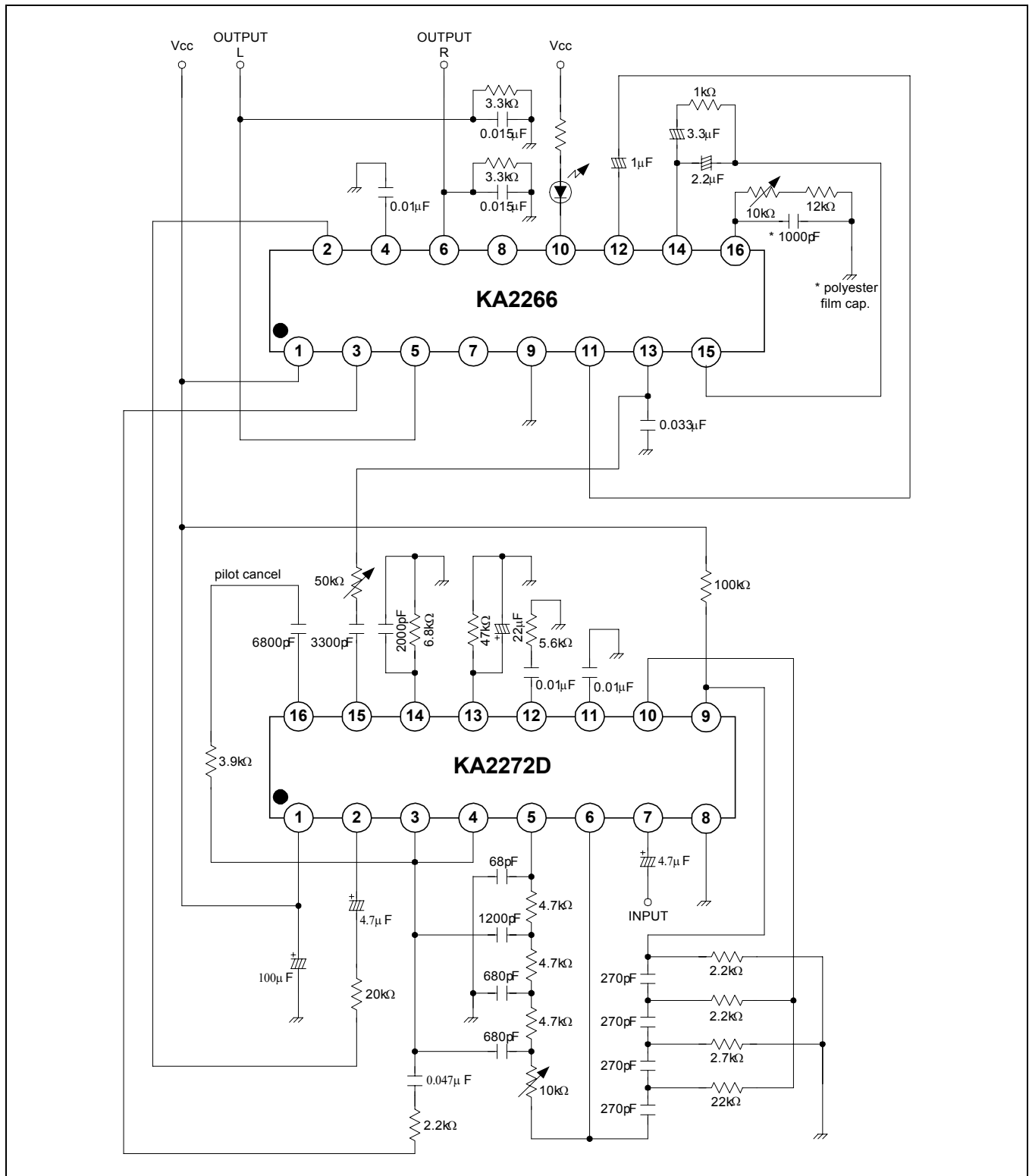

Figure 3.