

TC74ACT138P, TC74ACT138F, TC74ACT138FN, TC74ACT138FT

3 - TO - 8 LINE DECODER

The TC74ACT138 is an advanced high speed CMOS 3 - to - 8 LINE DECODER fabricated with silicon gate and double - layer metal wiring C²MOS technology. It achieves the high speed operation similar to equivalent Bipolar Schottky TTL while maintaining the CMOS low power dissipation.

This device may be used as a level converter for interfacing TTL or NMOS to High Speed CMOS. The inputs are compatible with TTL, NMOS and CMOS output voltage levels.

When the device is enabled, 3 Binary Select inputs (A, B and C) determine which one of the outputs ($\bar{Y}0$ - $\bar{Y}7$) will go low.

When enable input G1 is held low or either $\bar{G}2A$ or $\bar{G}2B$ is held high, decoding function is inhibited and all outputs go high.

G1, $\bar{G}2A$, and $\bar{G}2B$ inputs are provided to ease cascade connection and for use as an address decoder for memory systems.

All inputs are equipped with protection circuits against static discharge or transient excess voltage.

FEATURES :

- High Speed..... $t_{pd} = 6.0ns$ (typ.) at $V_{CC} = 5V$
- Low Power Dissipation..... $I_{CC} = 8\mu A$ (Max.) at $T_a = 25^\circ C$
- Compatible with TTL outputs ... $V_{IL} = 0.8V$ (Max.)
 $V_{IH} = 2.0V$ (Min.)
- Symmetrical Output Impedance... $|I_{OH}| = I_{OL} = 24mA$ (Min.)
Capability of driving 50 Ω transmission lines.
- Balanced Propagation Delays..... $t_{pLH} \approx t_{pHL}$
- Pin and Function Compatible with 74F138

(Note) The JEDEC SOP (FN) is not available in Japan.

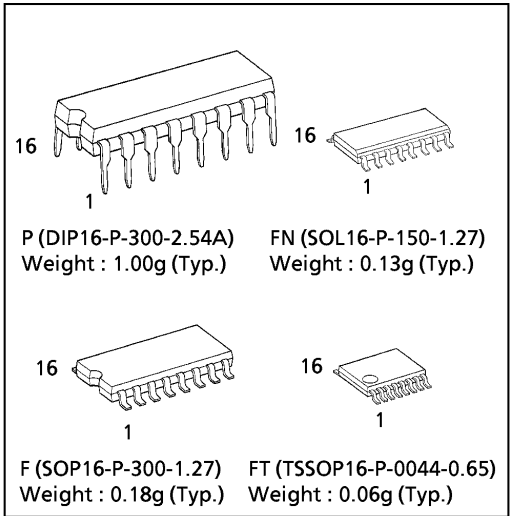

PIN ASSIGNMENT

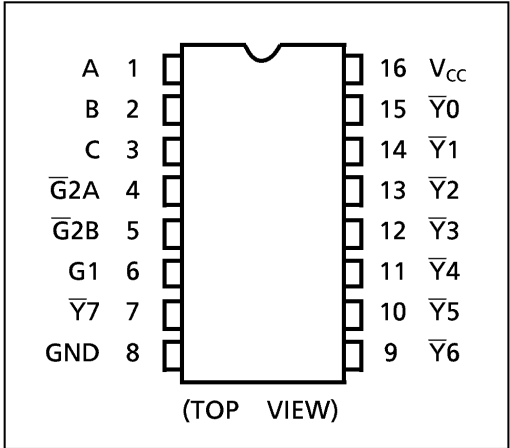

IEC LOGIC SYMBOL

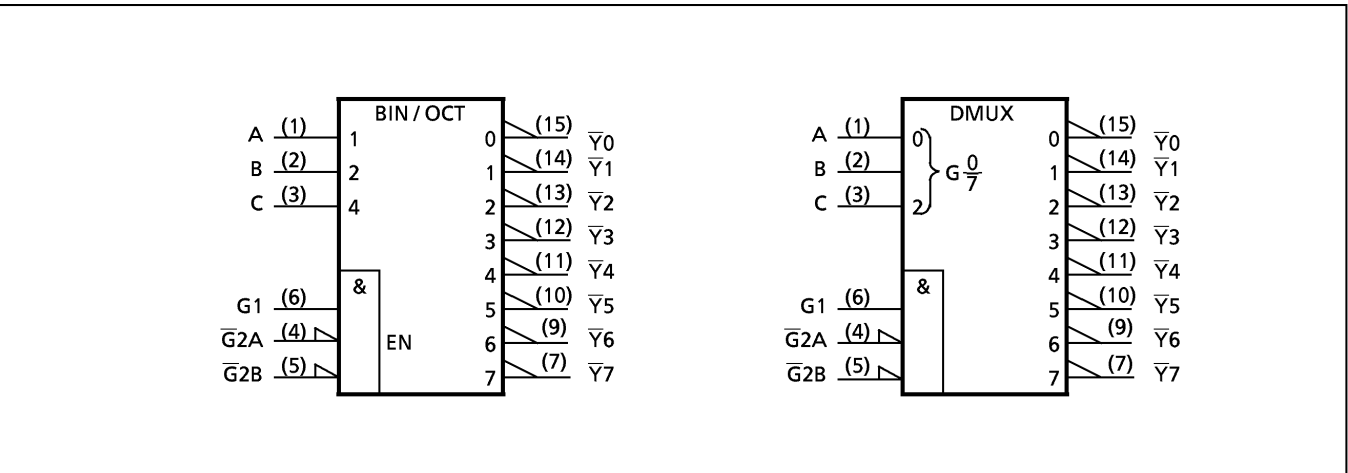

961001EBA2

● TOSHIBA is continually working to improve the quality and the reliability of its products. Nevertheless, semiconductor devices in general can malfunction or fail due to their inherent electrical sensitivity and vulnerability to physical stress. It is the responsibility of the buyer, when utilizing TOSHIBA products, to observe standards of safety, and to avoid situations in which a malfunction or failure of a TOSHIBA product could cause loss of human life, bodily injury or damage to property. In developing your designs, please ensure that TOSHIBA products are used within specified operating ranges as set forth in the most recent products specifications. Also, please keep in mind the precautions and conditions set forth in the TOSHIBA Semiconductor Reliability Handbook.

TRUTH TABLE

INPUTS						OUTPUTS								SELECTED OUTPUT
ENABLE			SELECT			Y ₀	Y ₁	Y ₂	Y ₃	Y ₄	Y ₅	Y ₆	Y ₇	
G1	G _{2A}	G _{2B}	C	B	A									
L	X	X	X	X	X	H	H	H	H	H	H	H	H	NONE
X	H	X	X	X	X	H	H	H	H	H	H	H	H	NONE
X	X	H	X	X	X	H	H	H	H	H	H	H	H	NONE
H	L	L	L	L	L	L	H	H	H	H	H	H	H	Y ₀
H	L	L	L	L	H	H	L	H	H	H	H	H	H	Y ₁
H	L	L	L	H	L	H	H	L	H	H	H	H	H	Y ₂
H	L	L	L	H	H	H	H	H	L	H	H	H	H	Y ₃
H	L	L	H	L	L	H	H	H	H	L	H	H	H	Y ₄
H	L	L	H	L	H	H	H	H	H	H	L	H	H	Y ₅
H	L	L	H	H	L	H	H	H	H	H	H	L	H	Y ₆
H	L	L	H	H	H	H	H	H	H	H	H	H	L	Y ₇

X : Don't Care

LOGIC DIAGRAM

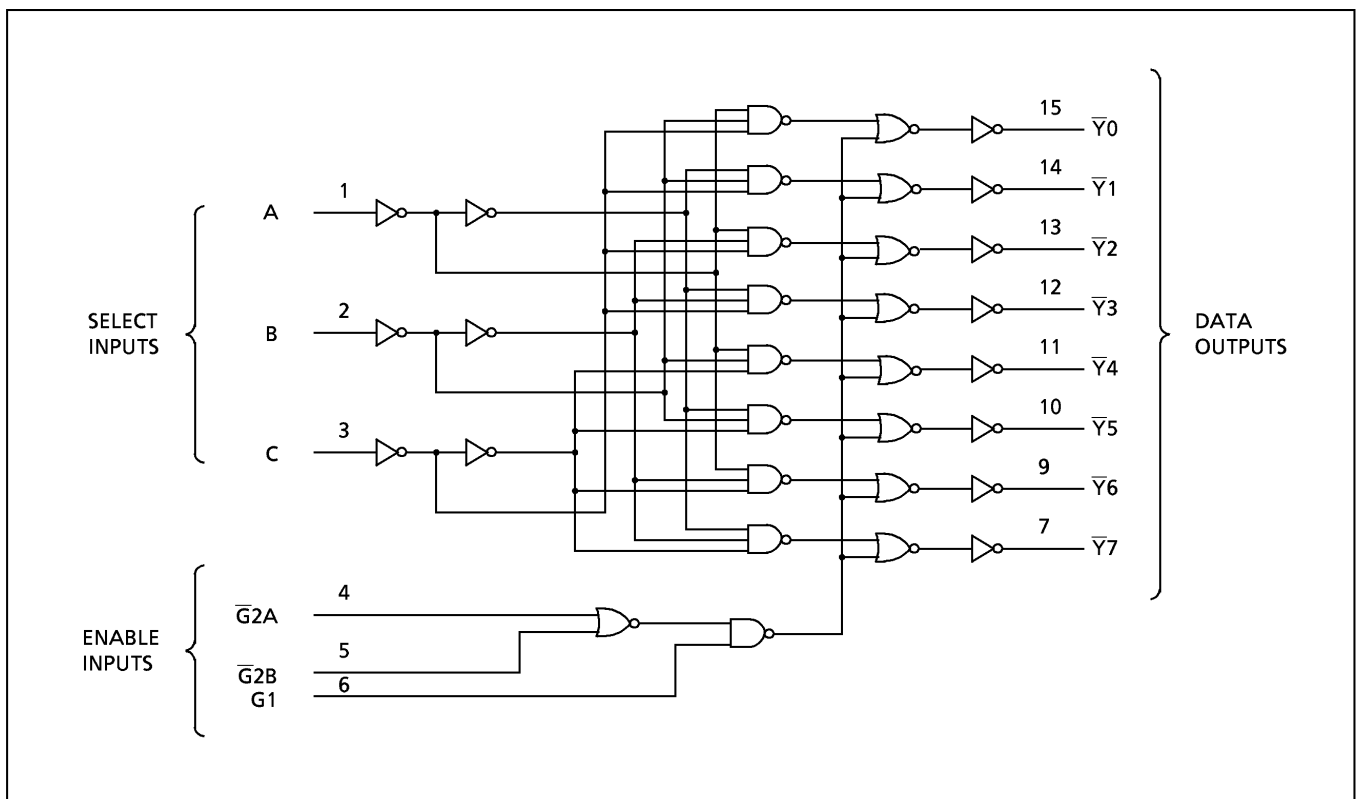

961001EBA2'

- The products described in this document are subject to foreign exchange and foreign trade control laws.
- The information contained herein is presented only as a guide for the applications of our products. No responsibility is assumed by TOSHIBA CORPORATION for any infringements of intellectual property or other rights of the third parties which may result from its use. No license is granted by implication or otherwise under any intellectual property or other rights of TOSHIBA CORPORATION or others.
- The information contained herein is subject to change without notice.

ABSOLUTE MAXIMUM RATINGS

PARAMETER	SYMBOL	VALUE	UNIT
Supply Voltage Range	V _{CC}	-0.5~7.0	V
DC Input Voltage	V _{IN}	-0.5~V _{CC} +0.5	V
DC Output Voltage	V _{OUT}	-0.5~V _{CC} +0.5	V
Input Diode Current	I _{IK}	±20	mA
Output Diode Current	I _{OK}	±50	mA
DC Output Current	I _{OUT}	±50	mA
DC V _{CC} /Ground Current	I _{CC}	±200	mA
Power Dissipation	P _D	500 (DIP)* / 180 (SOP/TSSOP)	mW
Storage Temperature	T _{stg}	-65~150	°C

*500mW in the range of Ta = -40°C~65°C. From Ta = 65°C to 85°C a derating factor of -10mW/°C should be applied up to 300mW.

RECOMMENDED OPERATING CONDITIONS

PARAMETER	SYMBOL	VALUE	UNIT
Supply Voltage	V _{CC}	4.5~5.5	V
Input Voltage	V _{IN}	0~V _{CC}	V
Output Voltage	V _{OUT}	0~V _{CC}	V
Operating Temperature	T _{opr}	-40~85	°C
Input Rise and Fall Time	dt / dV	0~10	ns / V

DC ELECTRICAL CHARACTERISTICS

PARAMETER	SYMBOL	TEST CONDITION	V _{CC} (V)	Ta = 25°C			Ta = -40~85°C		UNIT	
				MIN.	TYP.	MAX.	MIN.	MAX.		
High - Level Input Voltage	V _{IH}		4.5 } 5.5	2.0	—	—	2.0	—	V	
Low - Level Input Voltage	V _{IL}		4.5 } 5.5	—	—	0.8	—	0.8	V	
High - Level Output Voltage	V _{OH}	V _{IN} = V _{IH} or V _{IL}	I _{OH} = -50μA	4.5	4.4	4.5	—	4.4	—	V
			I _{OH} = -24mA	4.5	3.94	—	—	3.80	—	
			I _{OH} = -75mA*	5.5	—	—	—	3.85	—	
Low - Level Output Voltage	V _{OL}	V _{IN} = V _{IH} or V _{IL}	I _{OL} = 50μA	4.5	—	0.0	0.1	—	0.1	V
			I _{OL} = 24mA	4.5	—	—	0.36	—	0.44	
			I _{OL} = 75mA*	5.5	—	—	—	—	1.65	
Input Leakage Current	I _{IN}	V _{IN} = V _{CC} or GND	5.5	—	—	±0.1	—	±1.0	μA	
Quiescent Supply Current	I _{CC}	V _{IN} = V _{CC} or GND	5.5	—	—	8.0	—	80.0		
		I _C	PER INPUT : V _{IN} = 3.4V OTHER INPUT : V _{CC} or GND	5.5	—	—	1.35	—	1.5	mA

* : This spec indicates the capability of driving 50Ω transmission lines.
One output should be tested at a time for a 10ms maximum duration.

AC ELECTRICAL CHARACTERISTICS ($C_L = 50\text{pF}$, $R_L = 500\Omega$, Input $t_r = t_f = 3\text{ns}$)

PARAMETER	SYMBOL	TEST CONDITION	Ta = 25°C			Ta = -40~85°C		UNIT	
			V _{CC} (V)	MIN.	TYP.	MAX.	MIN.		MAX.
Propagation Delay Time (A, B, C- \bar{Y})	t_{pLH} t_{pHL}		5.0 ± 0.5	—	6.7	10.1	1.0	11.5	ns
Propagation Delay Time (G1- \bar{Y})	t_{pLH} t_{pHL}		5.0 ± 0.5	—	6.8	10.5	1.0	12.0	
Propagation Delay Time ($\bar{G}2$ - \bar{Y})	t_{pLH} t_{pHL}		5.0 ± 0.5	—	6.9	11.0	1.0	12.5	
Input Capacitance	C _{IN}			—	5	10	—	10	pF
Power Dissipation Capacitance	C _{PD} (1)			—	55	—	—	—	

Note (1) C_{PD} is defined as the value of the internal equivalent capacitance which is calculated from the operating current consumption without load.

Average operating current can be obtained by the equation :

$$I_{CC(\text{opr.})} = C_{PD} \cdot V_{CC} \cdot f_{IN} + I_{CC}$$

DIP 16PIN OUTLINE DRAWING (DIP16-P-300-2.54A)

Unit in mm

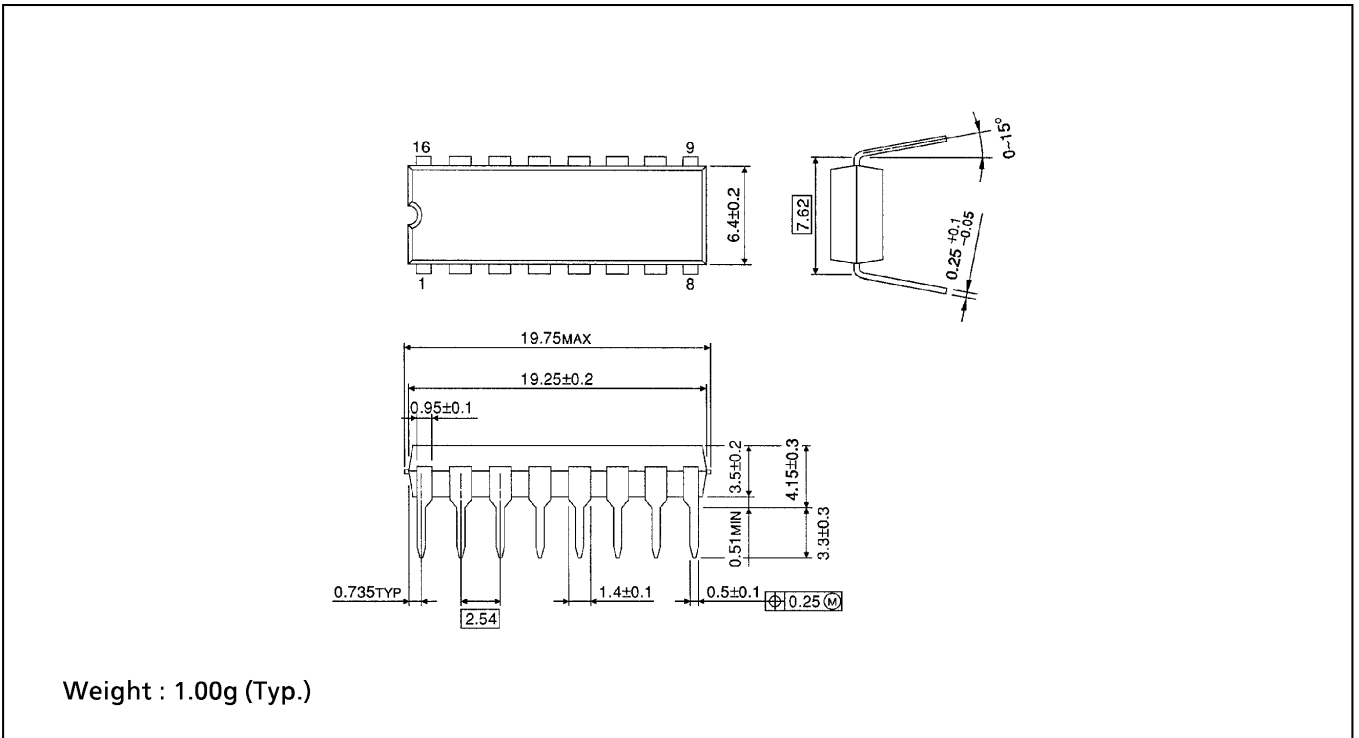

SOP 16PIN (200mil BODY) OUTLINE DRAWING (SOP16-P-300-1.27)

Unit in mm

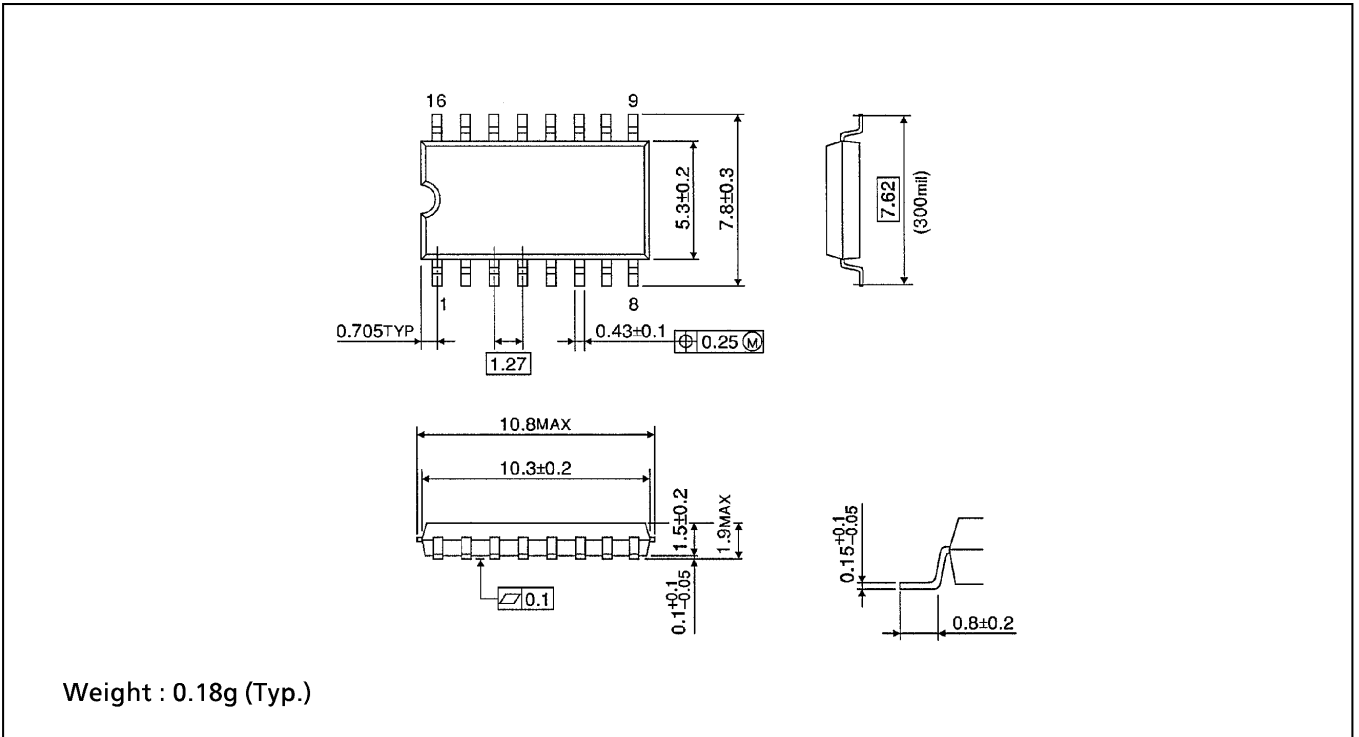

SOP 16PIN (150mil BODY) OUTLINE DRAWING (SOL16-P-150 -1.27)

Unit in mm

(Note) This package is not available in Japan.

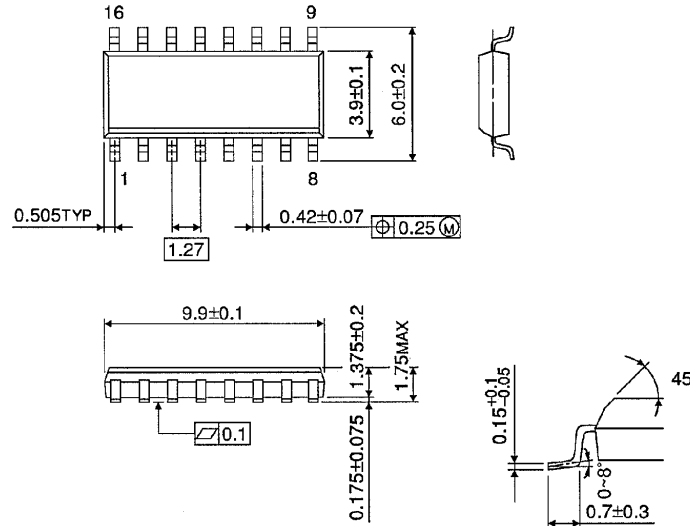

Weight : 0.13g (Typ.)

TSSOP 16PIN OUTLINE DRAWING (TSSOP16-P-0044-0.65)

Unit in mm

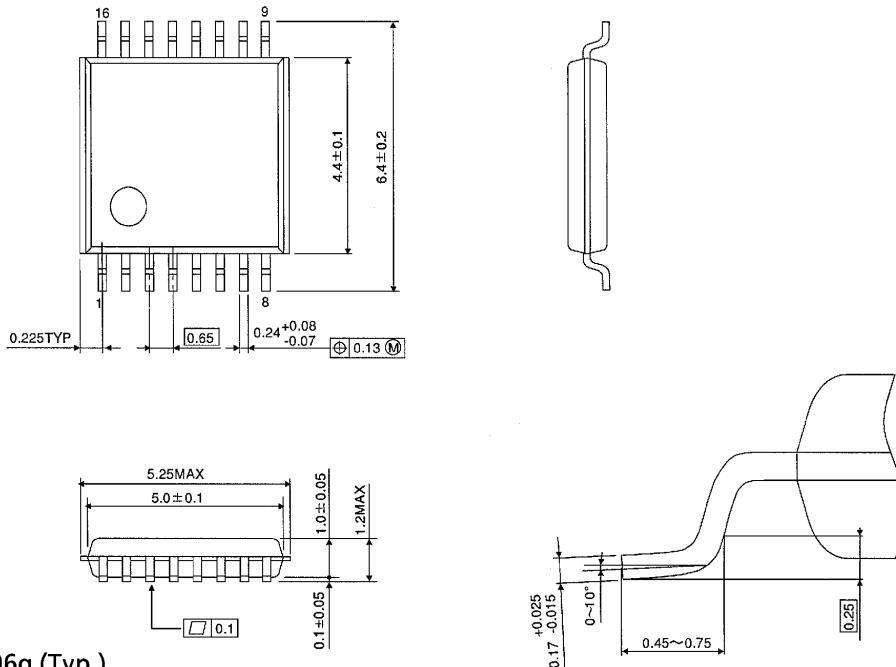

Weight : 0.06g (Typ.)