

# DATA SHEET

**74F240**

Octal inverter buffer (3-State)

**74F241/74F241A**

Octal buffer (3-State)

Product data  
Supersedes data of 1991 Jan 02

2002 Mar 18

# Buffers

# 74F240/74F241/74F241A

## FEATURES

- Octal bus interface
- 3-State buffer outputs sink 64 mA
- 15 mA source current
- Guaranteed output skew less than 2.0 ns (74F241A)
- Reduced ground bounce (74F241A)
- Reduced  $I_{CC}$  (74F241A only)
- Reduced loading (74F241A  $I_{IL} = 40 \mu\text{A}$ )

## DESCRIPTION

The 74F240 and 74F241 are octal buffers that are ideal for driving bus lines of buffer memory address registers. The outputs are all capable of sinking 64 mA and sourcing up to 15 mA. The device features two output enables, each controlling four of the 3-state outputs.

The 74F241A is functionally equivalent to its non-A counterpart. It has been designed to reduce effects of ground noise. Other advantages are noted in the features.

TYPE	TYPICAL PROPAGATION DELAY	TYPICAL SUPPLY CURRENT (TOTAL)
74F240	4.3 ns	37 mA
74F241	5.0 ns	53 mA
74F241A	4.5 ns	32 mA

## ORDERING INFORMATION

DESCRIPTION	ORDER CODE	PKG DWG #
	COMMERCIAL RANGE $V_{CC} = 5 \text{ V} \pm 10\%$ , $T_{amb} = 0 \text{ }^\circ\text{C to } +70 \text{ }^\circ\text{C}$	
20-pin plastic DIP	N74F240N, N74F241N, N74F241AN	SOT146-1
20-pin plastic SOL	N74F240D, N74F241D, N74F241AD	SOT163-1
20-pin plastic SSOP II	N74F240DB	SOT339-1

## INPUT AND OUTPUT LOADING AND FAN OUT TABLE

PINS	DESCRIPTION	74F (U.L.) HIGH/LOW	LOAD VALUE HIGH/LOW
I <sub>an</sub> , I <sub>bn</sub>	Data inputs (74F240)	1.0/1.67	20 $\mu\text{A}$ /1.0 mA
	Data inputs (74F241)	1.0/2.67	20 $\mu\text{A}$ /1.6 mA
	Data inputs (74F241A)	1.0/0.067	20 $\mu\text{A}$ /40 $\mu\text{A}$
$\overline{\text{OE}}_a$ , $\overline{\text{OE}}_b$	Output enable inputs (Active-LOW) (74F240)	1.0/0.33	20 $\mu\text{A}$ /0.2 mA
$\overline{\text{OE}}_a$ , OE <sub>b</sub>	Output enable input (74F241)	1.0/1.67	20 $\mu\text{A}$ /1.0 mA
	Output enable input (74F241A)	1.0/0.067	20 $\mu\text{A}$ /40 $\mu\text{A}$
Y <sub>an</sub> , Y <sub>bn</sub>	Data outputs (74F241, 74F241A)	750/106.7	15 mA/64 mA
$\overline{\text{Y}}_a$ , $\overline{\text{Y}}_b$	Data outputs (74F240)	750/106.7	15 mA/64 mA

### Note to input and output loading and fan out table

One (1.0) FAST unit load is defined as: 20  $\mu\text{A}$  in the HIGH state and 0.6 mA in the LOW state.

# Buffers

# 74F240/74F241/74F241A

## PIN CONFIGURATION FOR 74F240

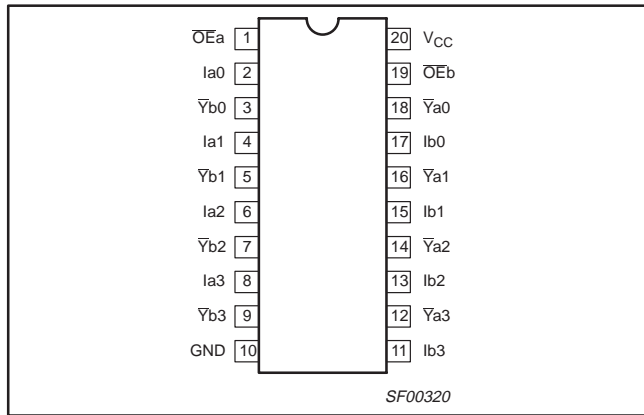

## IEC/IEEE SYMBOL FOR 74F240

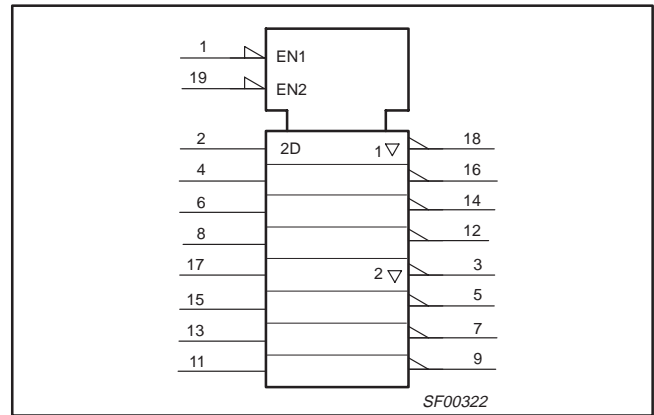

## LOGIC SYMBOL FOR 74F240

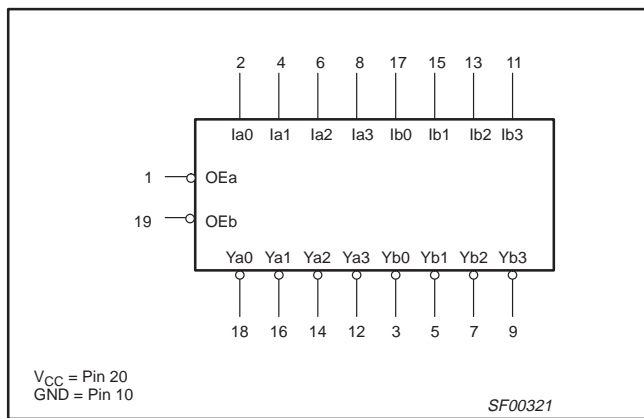

## LOGIC DIAGRAM FOR 74F240

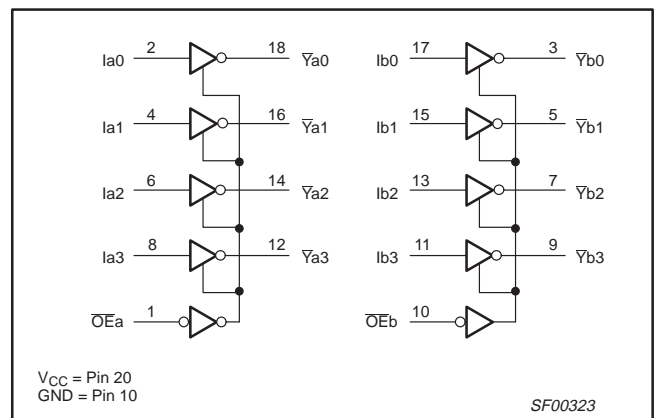

## FUNCTION TABLE FOR 74F240

INPUTS				OUTPUTS	
$\overline{OEa}$	Ia	$\overline{OEb}$	Ib	Ya	Yb
L	L	L	L	H	H
L	H	L	H	L	L
H	X	H	X	Z	Z

### NOTES:

- H = High voltage level
- L = Low voltage level
- X = Don't care
- Z = High impedance "off" state

# Buffers

# 74F240/74F241/74F241A

### PIN CONFIGURATION FOR 74F241/74F241A

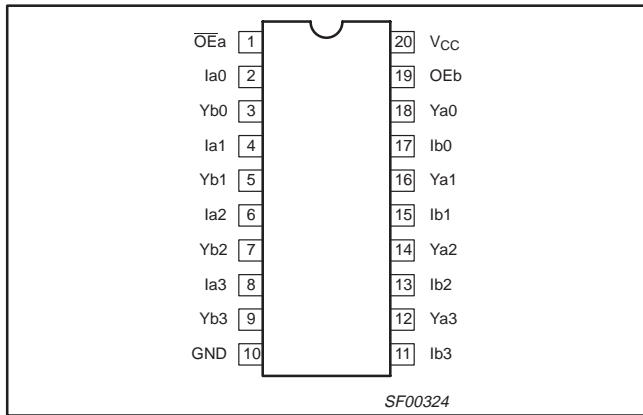

### IEC/IEEE SYMBOL FOR 74F241/74F241A

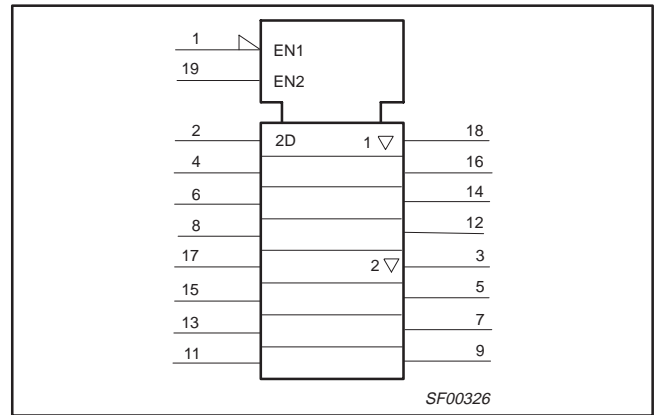

### LOGIC SYMBOL FOR 74F241/74F241A

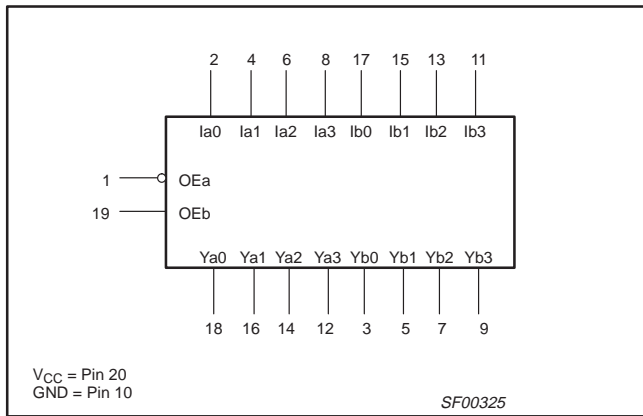

### LOGIC DIAGRAM FOR 74F241/74F241A

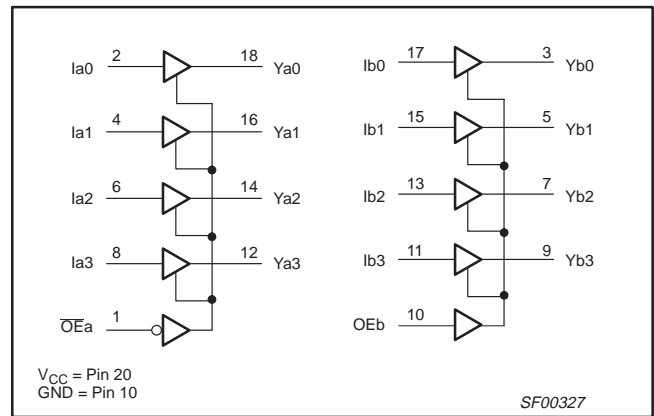

### FUNCTION TABLE FOR 74F241/74F241A

INPUTS			OUTPUTS		
OEa	Ia	OEb	Ib	Ya	Yb
L	L	H	L	L	L
L	H	H	H	H	H
H	X	L	X	Z	Z

#### NOTES:

- H = High voltage level
- L = Low voltage level
- X = Don't care
- Z = High impedance "off" state

## Buffers

## 74F240/74F241/74F241A

**ABSOLUTE MAXIMUM RATINGS**

(Operation beyond the limit set forth in this table may impair the useful life of the device.  
Unless otherwise noted these limits are over the operating free air temperature range.)

SYMBOL	PARAMETER	RATING	UNIT
V <sub>CC</sub>	Supply voltage	-0.5 to +7.0	V
V <sub>IN</sub>	Input voltage	-0.5 to +7.0	V
I <sub>IN</sub>	Input current	-30 to +5	mA
V <sub>OUT</sub>	Voltage applied to output in high output state	-0.5 to V <sub>CC</sub>	V
I <sub>OUT</sub>	Current applied to output in low output state	128	mA
T <sub>amb</sub>	Operating free air temperature range	0 to +70	°C
T <sub>stg</sub>	Storage temperature range	-65 to +150	°C

**RECOMMENDED OPERATING CONDITIONS**

SYMBOL	PARAMETER	LIMITS			UNIT
		MIN	NOM	MAX	
V <sub>CC</sub>	Supply voltage	4.5	5.0	5.5	V
V <sub>IH</sub>	High-level input voltage	2.0			V
V <sub>IL</sub>	Low-level input voltage			0.8	V
I <sub>IK</sub>	Input clamp current			-18	mA
I <sub>OH</sub>	High-level output current			-15	mA
I <sub>OL</sub>	Low-level output current			64	mA
T <sub>amb</sub>	Operating free air temperature range	0		+70	°C

## Buffers

## 74F240/74F241/74F241A

## DC ELECTRICAL CHARACTERISTICS

(Over recommended operating free-air temperature range unless otherwise noted.)

SYMBOL	PARAMETER		TEST CONDITIONS <sup>1</sup>			LIMITS			UNIT	
						MIN	TYP <sup>2</sup>	MAX		
V <sub>OH</sub>	High-level output voltage		V <sub>CC</sub> = MIN; V <sub>IL</sub> = MAX; V <sub>IH</sub> = MIN	I <sub>OH</sub> = -3 mA	±10%V <sub>CC</sub>	2.4			V	
					±5%V <sub>CC</sub>	2.7	3.4		V	
				I <sub>OH</sub> = -15 mA	±10%V <sub>CC</sub>	2.0			V	
					±5%V <sub>CC</sub>	2.0			V	
V <sub>OL</sub>	Low-level output voltage		V <sub>CC</sub> = MIN; V <sub>IL</sub> = MAX; V <sub>IH</sub> = MIN	I <sub>OL</sub> = MAX	±10%V <sub>CC</sub>			0.50	V	
					±5%V <sub>CC</sub>		0.42	0.50	V	
V <sub>IK</sub>	Input clamp voltage		V <sub>CC</sub> = MIN; I <sub>I</sub> = I <sub>IK</sub>				-0.73	-1.2	V	
I <sub>I</sub>	Input current at maximum input voltage		V <sub>CC</sub> = MAX; V <sub>I</sub> = 7.0 V					100	μA	
I <sub>IH</sub>	High-level input current		V <sub>CC</sub> = MAX; V <sub>I</sub> = 2.7 V					20	μA	
I <sub>IL</sub>	Low-level input current		V <sub>CC</sub> = MAX; V <sub>I</sub> = 0.5 V			74F240 all inputs			-1.0	mA
						74F241 $\overline{O}Ea, OEb$			-1.0	mA
						74F241 I <sub>an</sub> , I <sub>bn</sub>			-1.6	mA
						74F241A all inputs			-40	μA
I <sub>OZH</sub>	Off-state output current, high-level voltage applied		V <sub>CC</sub> = MAX, V <sub>O</sub> = 2.7 V					50	μA	
I <sub>OZL</sub>	Off-state output current, low-level voltage applied		V <sub>CC</sub> = MAX, V <sub>O</sub> = 0.5 V					-50	μA	
I <sub>OS</sub>	Short-circuit output current <sup>3</sup>		V <sub>CC</sub> = MAX			-100		-225	mA	
I <sub>CC</sub>	Supply current (total)		74F240		V <sub>CC</sub> = MAX	I <sub>CCH</sub>		12	18	mA
						I <sub>CCL</sub>		50	70	mA
						I <sub>CCZ</sub>		35	45	mA
			74F241			I <sub>CCH</sub>		40	60	mA
						I <sub>CCL</sub>		60	90	mA
						I <sub>CCZ</sub>		65	90	mA
			74F241A			I <sub>CCH</sub>		20	30	mA
						I <sub>CCL</sub>		49	65	mA
						I <sub>CCZ</sub>		26	40	mA

## NOTES:

- For conditions shown as MIN or MAX, use the appropriate value specified under recommended operating conditions for the applicable type.
- All typical values are at V<sub>CC</sub> = 5 V, T<sub>amb</sub> = 25 °C.
- Not more than one output should be shorted at a time. For testing I<sub>OS</sub>, the use of high-speed test apparatus and/or sample-and-hold techniques are preferable in order to minimize internal heating and more accurately reflect operational values. Otherwise, prolonged shorting of a high output may raise the chip temperature well above normal and thereby cause invalid readings in other parameter tests. In any sequence of parameter tests, I<sub>OS</sub> tests should be performed last.

## Buffers

## 74F240/74F241/74F241A

## AC ELECTRICAL CHARACTERISTICS

SYMBOL	PARAMETER	TEST CONDITION	LIMITS					UNIT	
			T <sub>amb</sub> = +25 °C V <sub>CC</sub> = +5.0 V C <sub>L</sub> = 50 pF; R <sub>L</sub> = 500 Ω			T <sub>amb</sub> = 0 °C to +70 °C V <sub>CC</sub> = +5.0 V ± 10% C <sub>L</sub> = 50 pF; R <sub>L</sub> = 500 Ω			
			MIN	TYP	MAX	MIN	MAX		
t <sub>PLH</sub> t <sub>PHL</sub>	Propagation delay I <sub>an</sub> , I <sub>bn</sub> to Y <sub>n</sub>	74F240	Waveform 1	3.0 2.0	4.5 3.0	6.5 4.5	3.0 2.0	7.5 5.0	ns
t <sub>PZH</sub> t <sub>PZL</sub>	Output enable time to high or low level		Waveform 3 Waveform 4	3.0 4.5	5.0 6.5	7.5 8.5	3.0 4.0	9.0 10.0	ns
t <sub>PHZ</sub> t <sub>PLZ</sub>	Output disable time from high or low level		Waveform 3 Waveform 4	3.0 3.0	5.5 5.0	7.0 7.0	3.0 3.0	7.5 7.5	ns
t <sub>PLH</sub> t <sub>PHL</sub>	Propagation delay I <sub>an</sub> , I <sub>bn</sub> to Y <sub>n</sub>	74F241	Waveform 2	2.5 2.5	4.0 4.0	5.2 5.2	2.5 2.5	6.2 6.5	ns
t <sub>PZH</sub> t <sub>PZL</sub>	Output enable time to high or low level		Waveform 3 Waveform 4	2.0 2.0	4.0 5.0	5.7 7.0	2.0 2.0	6.7 8.0	ns
t <sub>PHZ</sub> t <sub>PLZ</sub>	Output disable time from high or low level		Waveform 3 Waveform 4	2.0 2.0	4.0 4.0	6.0 6.0	2.0 2.0	7.0 7.0	ns
t <sub>PLH</sub> t <sub>PHL</sub>	Propagation delay I <sub>an</sub> , I <sub>bn</sub> to Y <sub>n</sub>	74F241A	Waveform 2	2.5 2.5	4.5 4.5	5.8 5.8	2.5 2.5	6.5 6.5	ns
t <sub>PZH</sub> t <sub>PZL</sub>	Output enable time to high or low level		Waveform 3 Waveform 4	2.5 3.5	4.5 5.0	6.0 7.0	2.0 3.0	6.7 8.0	ns
t <sub>PHZ</sub> t <sub>PLZ</sub>	Output disable time from high or low level		Waveform 3 Waveform 4	2.0 1.5	4.0 3.5	6.0 5.5	1.5 1.0	6.5 6.0	ns
t <sub>sk(0)</sub>	Output skew <sup>1, 2</sup>		Waveform 5			1.5		2.0	ns

## NOTES:

1. |t<sub>PN</sub> actual – t<sub>PM</sub> actual| for any output compared to any other output where N and M are either LH or HL.
2. Skew times are valid only under same test conditions (temperature, V<sub>CC</sub>, loading, etc.).

Buffers

74F240/74F241/74F241A

AC WAVEFORMS

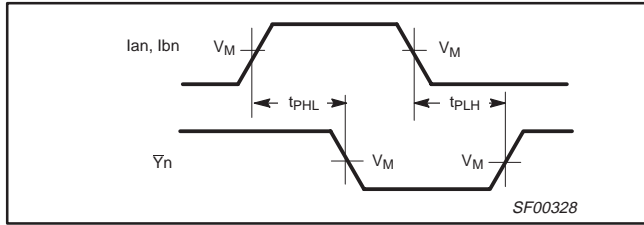

Waveform 1. Propagation delay for inverting outputs

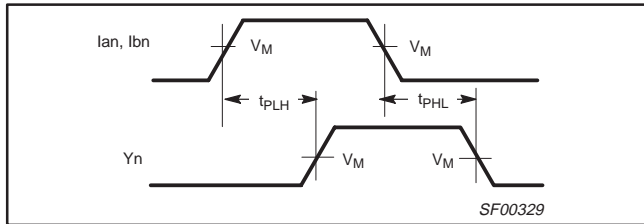

Waveform 2. Propagation delay for non-inverting outputs

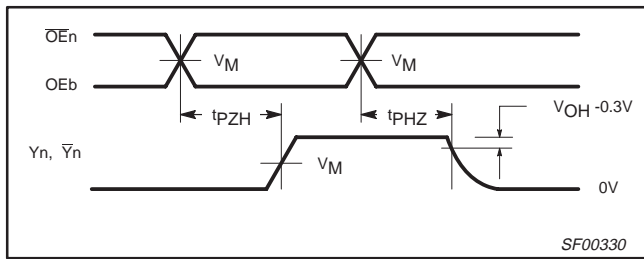

Waveform 3. 3-state output enable time to high level and output disable time from high level

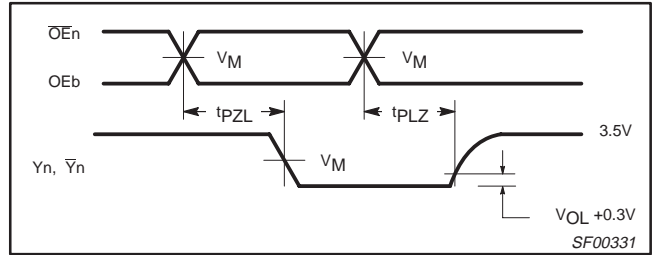

Waveform 4. 3-state output enable time to low level and output disable time from low level

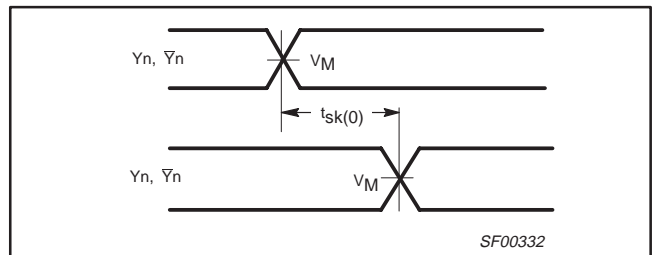

Waveform 5. Output skew

Notes to AC waveforms

1. For all waveforms,  $V_M = 1.5$  V.
2. The shaded areas indicate when the input is permitted to change for predictable output performance.



# Buffers

# 74F240/74F241/74F241A

## TEST CIRCUIT AND WAVEFORMS

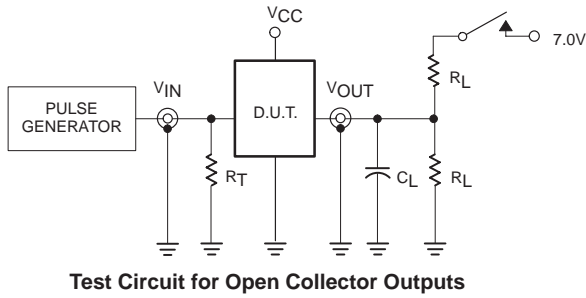

### SWITCH POSITION

TEST	SWITCH
$t_{PLZ}$	closed
$t_{PZL}$	closed
All other	open

### DEFINITIONS:

- $R_L$  = Load resistor; see AC electrical characteristics for value.
- $C_L$  = Load capacitance includes jig and probe capacitance; see AC electrical characteristics for value.
- $R_T$  = Termination resistance should be equal to  $Z_{OUT}$  of pulse generators.

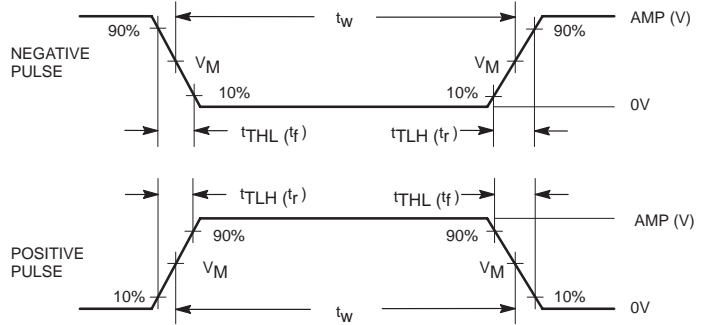

family	INPUT PULSE REQUIREMENTS					
	amplitude	$V_M$	rep. rate	$t_w$	$t_{TLH}$	$t_{THL}$
74F	3.0V	1.5V	1MHz	500ns	2.5ns	2.5ns

SF00128

Buffers

74F240/74F241/74F241A

DIP20: plastic dual in-line package; 20 leads (300 mil)

SOT146-1

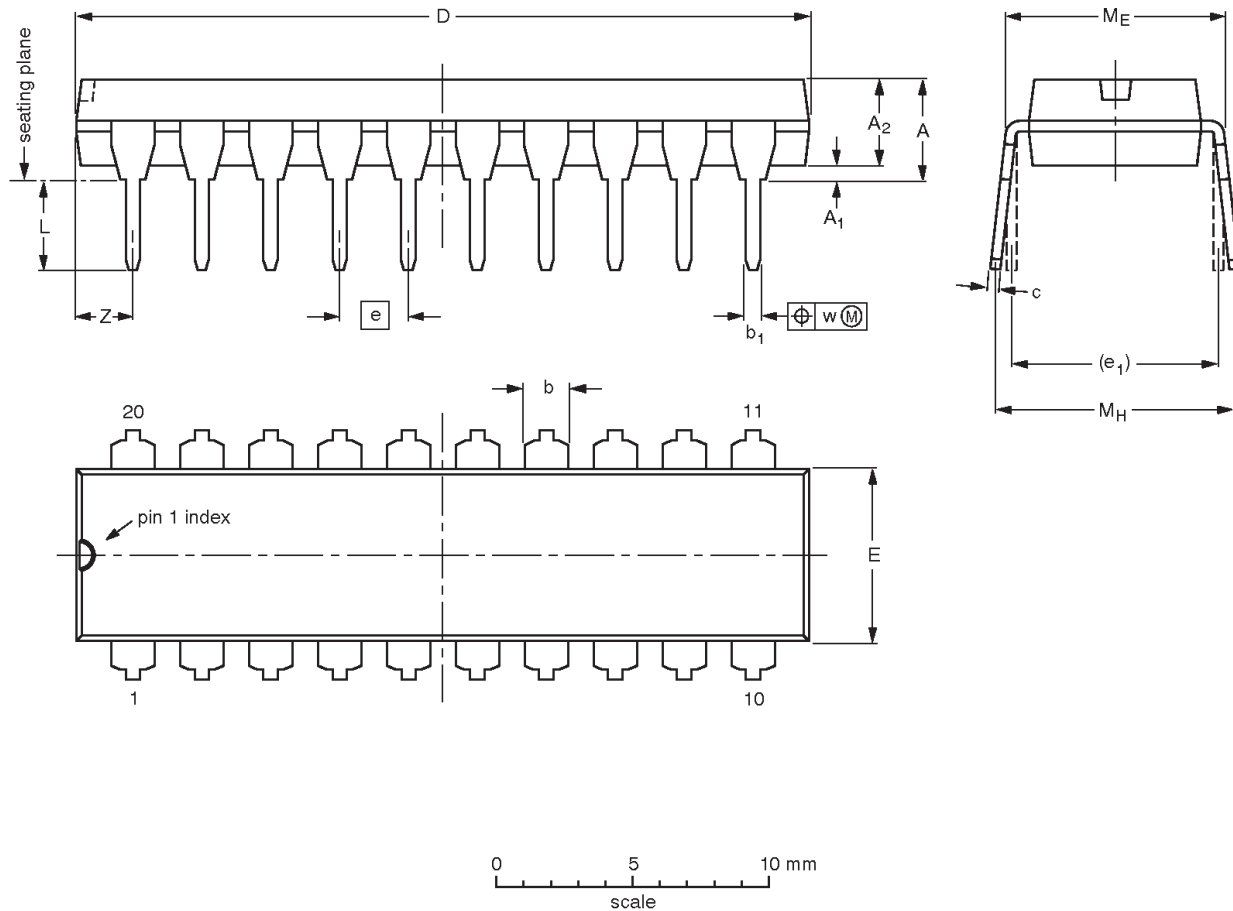

DIMENSIONS (inch dimensions are derived from the original mm dimensions)

UNIT	A max.	A <sub>1</sub> min.	A <sub>2</sub> max.	b	b <sub>1</sub>	c	D <sup>(1)</sup>	E <sup>(1)</sup>	e	e <sub>1</sub>	L	M <sub>E</sub>	M <sub>H</sub>	w	Z <sup>(1)</sup> max.
mm	4.2	0.51	3.2	1.73 1.30	0.53 0.38	0.36 0.23	26.92 26.54	6.40 6.22	2.54	7.62	3.60 3.05	8.25 7.80	10.0 8.3	0.254	2.0
inches	0.17	0.020	0.13	0.068 0.051	0.021 0.015	0.014 0.009	1.060 1.045	0.25 0.24	0.10	0.30	0.14 0.12	0.32 0.31	0.39 0.33	0.01	0.078

Note

1. Plastic or metal protrusions of 0.25 mm maximum per side are not included.

OUTLINE VERSION	REFERENCES				EUROPEAN PROJECTION	ISSUE DATE
	IEC	JEDEC	EIAJ			
SOT146-1		MS-001	SC-603			95-05-24 99-12-27

Buffers

74F240/74F241/74F241A

SO20: plastic small outline package; 20 leads; body width 7.5 mm

SOT163-1

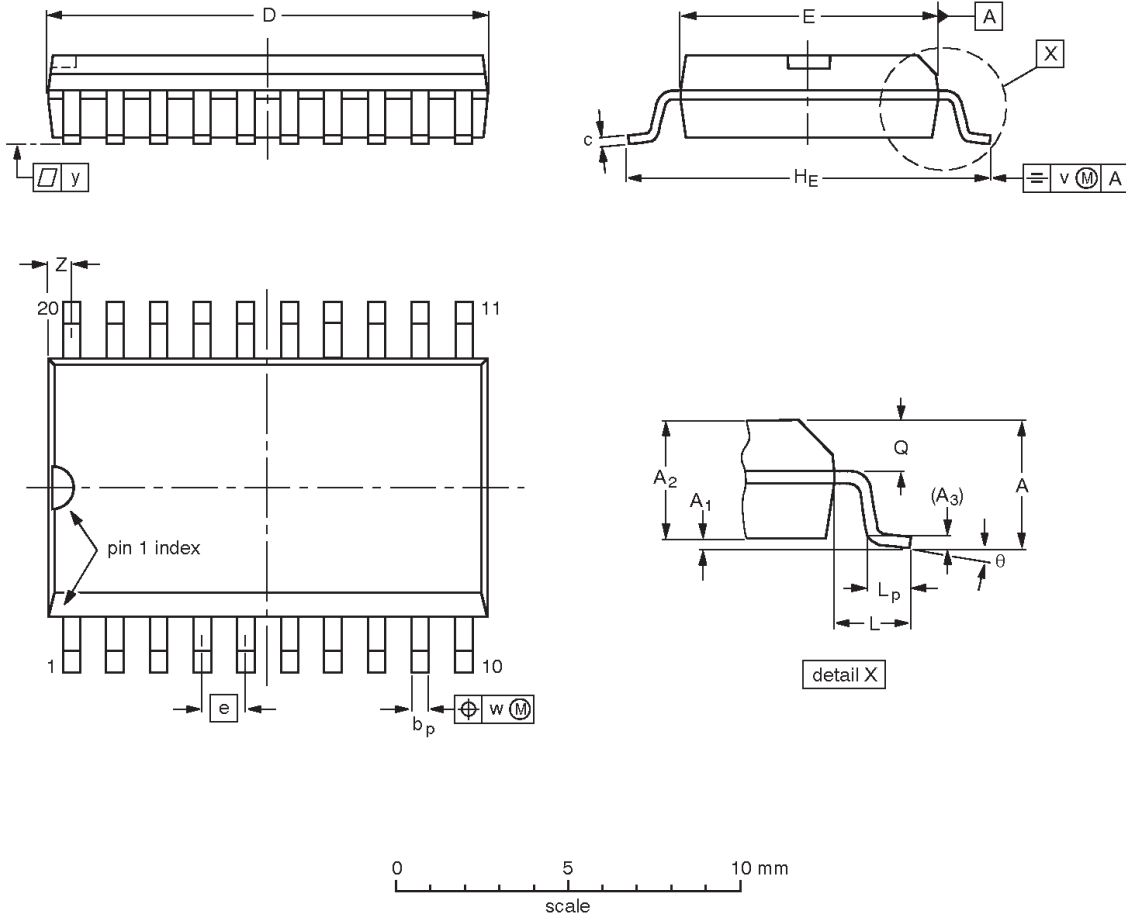

**DIMENSIONS (inch dimensions are derived from the original mm dimensions)**

UNIT	A max.	A <sub>1</sub>	A <sub>2</sub>	A <sub>3</sub>	b <sub>p</sub>	c	D <sup>(1)</sup>	E <sup>(1)</sup>	e	H <sub>E</sub>	L	L <sub>p</sub>	Q	v	w	y	z <sup>(1)</sup>	θ
mm	2.65	0.30 0.10	2.45 2.25	0.25	0.49 0.36	0.32 0.23	13.0 12.6	7.6 7.4	1.27	10.65 10.00	1.4	1.1 0.4	1.1 1.0	0.25	0.25	0.1	0.9 0.4	8° 0°
inches	0.10	0.012 0.004	0.096 0.089	0.01	0.019 0.014	0.013 0.009	0.51 0.49	0.30 0.29	0.050	0.419 0.394	0.055	0.043 0.016	0.043 0.039	0.01	0.01	0.004	0.035 0.016	

**Note**

1. Plastic or metal protrusions of 0.15 mm maximum per side are not included.

OUTLINE VERSION	REFERENCES				EUROPEAN PROJECTION	ISSUE DATE
	IEC	JEDEC	EIAJ			
SOT163-1	075E04	MS-013				97-05-22 99-12-27

Buffers

74F240/74F241/74F241A

SSOP20: plastic shrink small outline package; 20 leads; body width 5.3 mm

SOT339-1

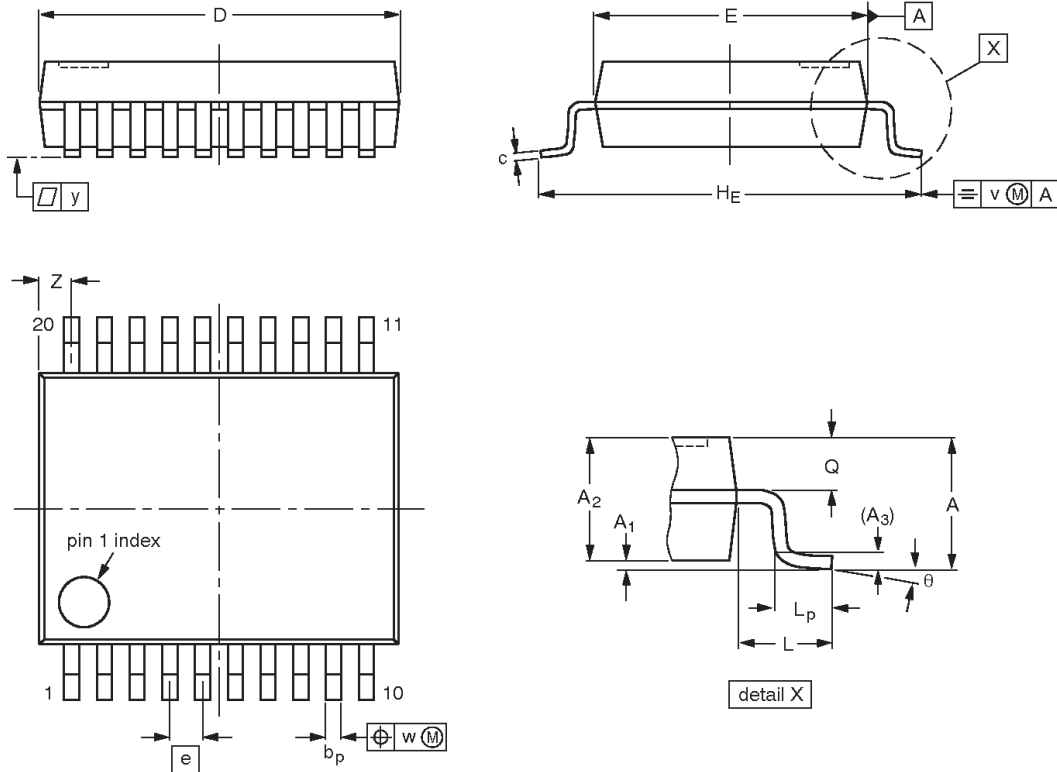

DIMENSIONS (mm are the original dimensions)

UNIT	A max.	A <sub>1</sub>	A <sub>2</sub>	A <sub>3</sub>	b <sub>p</sub>	c	D <sup>(1)</sup>	E <sup>(1)</sup>	e	HE	L	L <sub>p</sub>	Q	v	w	y	Z <sup>(1)</sup>	θ
mm	2.0	0.21 0.05	1.80 1.65	0.25	0.38 0.25	0.20 0.09	7.4 7.0	5.4 5.2	0.65	7.9 7.6	1.25	1.03 0.63	0.9 0.7	0.2	0.13	0.1	0.9 0.5	8° 0°

Note

1. Plastic or metal protrusions of 0.20 mm maximum per side are not included.

OUTLINE VERSION	REFERENCES				EUROPEAN PROJECTION	ISSUE DATE
	IEC	JEDEC	EIAJ			
SOT339-1		MO-150				95-02-04 99-12-27

---

# Buffers

74F240/74F241/74F241A

---

## NOTES

## Buffers

74F240/74F241/74F241A

## Data sheet status

Data sheet status <sup>[1]</sup>	Product status <sup>[2]</sup>	Definitions
Objective data	Development	This data sheet contains data from the objective specification for product development. Philips Semiconductors reserves the right to change the specification in any manner without notice.
Preliminary data	Qualification	This data sheet contains data from the preliminary specification. Supplementary data will be published at a later date. Philips Semiconductors reserves the right to change the specification without notice, in order to improve the design and supply the best possible product.
Product data	Production	This data sheet contains data from the product specification. Philips Semiconductors reserves the right to make changes at any time in order to improve the design, manufacturing and supply. Changes will be communicated according to the Customer Product/Process Change Notification (CPCN) procedure SNW-SQ-650A.

[1] Please consult the most recently issued data sheet before initiating or completing a design.

[2] The product status of the device(s) described in this data sheet may have changed since this data sheet was published. The latest information is available on the Internet at URL <http://www.semiconductors.philips.com>.

## Definitions

**Short-form specification** — The data in a short-form specification is extracted from a full data sheet with the same type number and title. For detailed information see the relevant data sheet or data handbook.

**Limiting values definition** — Limiting values given are in accordance with the Absolute Maximum Rating System (IEC 60134). Stress above one or more of the limiting values may cause permanent damage to the device. These are stress ratings only and operation of the device at these or at any other conditions above those given in the Characteristics sections of the specification is not implied. Exposure to limiting values for extended periods may affect device reliability.

**Application information** — Applications that are described herein for any of these products are for illustrative purposes only. Philips Semiconductors make no representation or warranty that such applications will be suitable for the specified use without further testing or modification.

## Disclaimers

**Life support** — These products are not designed for use in life support appliances, devices or systems where malfunction of these products can reasonably be expected to result in personal injury. Philips Semiconductors customers using or selling these products for use in such applications do so at their own risk and agree to fully indemnify Philips Semiconductors for any damages resulting from such application.

**Right to make changes** — Philips Semiconductors reserves the right to make changes, without notice, in the products, including circuits, standard cells, and/or software, described or contained herein in order to improve design and/or performance. Philips Semiconductors assumes no responsibility or liability for the use of any of these products, conveys no license or title under any patent, copyright, or mask work right to these products, and makes no representations or warranties that these products are free from patent, copyright, or mask work right infringement, unless otherwise specified.

## Contact information

For additional information please visit  
<http://www.semiconductors.philips.com>. Fax: +31 40 27 24825

© Koninklijke Philips Electronics N.V. 2002  
 All rights reserved. Printed in U.S.A.

Date of release: 03-02

For sales offices addresses send e-mail to:  
[sales.addresses@www.semiconductors.philips.com](mailto:sales.addresses@www.semiconductors.philips.com)

Document order number:

9397 750 09571

*Let's make things better.*