

Typical Applications

- PCS Communication Systems
- 2.5GHz ISM Band Applications
- Wireless LANs
- Commercial and Consumer Systems
- Portable Battery Powered Equipment

Product Description

The RF2128 is a medium-power, high-efficiency, linear amplifier IC. The device is manufactured on an advanced Gallium Arsenide Heterojunction Bipolar Transistor (HBT) process, and has been designed for use as the final RF amplifier in 2.45GHz ISM applications such as WLAN and POS terminals. The part also will function as the final stage in digital PCS phone transmitters requiring linear amplification operating between 1900MHz and 2200MHz, with over 100mW transmitted power, or as the driver stage for the RF2125 high power amplifier. A simple power down function is included for TDD operation.

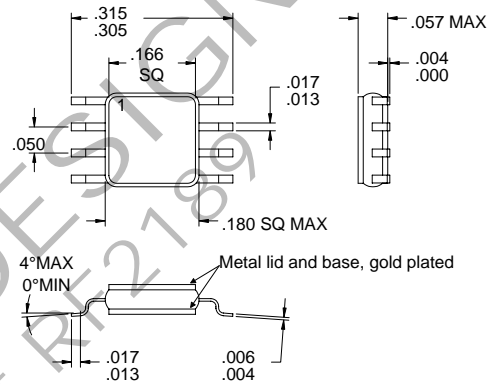

Optimum Technology Matching® Applied

- | | | |
|-------------------------------------|--|---------------------------------------|
| <input type="checkbox"/> Si BJT | <input checked="" type="checkbox"/> GaAs HBT | <input type="checkbox"/> GaAs MESFET |
| <input type="checkbox"/> Si Bi-CMOS | <input type="checkbox"/> SiGe HBT | <input type="checkbox"/> Si CMOS |
| <input type="checkbox"/> InGaP/HBT | <input type="checkbox"/> GaN HEMT | <input type="checkbox"/> SiGe Bi-CMOS |

Package Style: SOP-8-C

Features

- Single 3.0V to 6.5V Supply
- 100mW Linear Output Power
- 25dB Small Signal Gain
- 30% Efficiency
- Digitally Controlled Power Down Mode
- 1900MHz to 2500MHz Operation

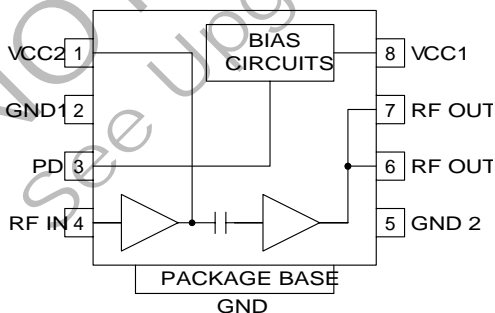

Functional Block Diagram

Ordering Information

RF2128	Medium Power Linear Amplifier
RF2128 PCBA	Fully Assembled Evaluation Board

RF Micro Devices, Inc.
7628 Thorndike Road
Greensboro, NC 27409, USA

Tel (336) 664 1233
Fax (336) 664 0454
<http://www.rfmd.com>

RF2128

Absolute Maximum Ratings

Parameter	Rating	Unit
Supply Voltage (V_{CC})	+7.5	V_{DC}
Power Down Voltage (V_{PD})	+5.5	V
DC Supply Current	125	mA
Input RF Power	+12	dBm
Output Load VSWR	20:1	
Operating Case Temperature	-40 to +100	°C
Operating Ambient Temperature	-40 to +85	°C
Storage Temperature	-40 to +150	°C



Caution! ESD sensitive device.

RF Micro Devices believes the furnished information is correct and accurate at the time of this printing. However, RF Micro Devices reserves the right to make changes to its products without notice. RF Micro Devices does not assume responsibility for the use of the described product(s).

Parameter	Specification			Unit	Condition
	Min.	Typ.	Max.		
Overall					$T=25^{\circ}\text{C}$, $V_{CC}=5\text{V}$, $V_{PD}=5.0\text{V}$, Freq=2400MHz
Frequency Range		1900 to 2500		MHz	
Maximum Output Power		>+20		dBm	$V_{CC}=5.0\text{V}$, $V_{PD}=5.0\text{V}$, $P_{IN}=-3.0\text{dBm}$
Maximum Output Power		>+23		dBm	$V_{CC}=6.0\text{V}$, $V_{PD}=5.5\text{V}$, $P_{IN}=0\text{dBm}$
Total CW Efficiency		30		%	Maximum output
Small-signal Gain		25		dB	
Second Harmonic		-25		dBc	
Third Harmonic		-22		dBc	
Isolation		15		dB	$V_{PD}=0.2\text{V}$
Input VSWR		2:1			
Input Impedance		50		Ω	
Noise Figure		7		dB	
Two-tone Specification					
Average Two-Tone Power		+17		dBm	PEP-3dB
IM ₃		-24		dBc	$P_{OUT}=+14\text{dBm}$ for each tone
IM ₅		-36		dBc	$P_{OUT}=+14\text{dBm}$ for each tone
IM ₇		-44		dBc	$P_{OUT}=+14\text{dBm}$ for each tone
Two-Tone Power-Added Efficiency		36		%	
Power Down Control					
Power Down "ON"		V_{CC}		V	Voltage supplied to the input; device is "on"
Power Down "OFF"	0		1.2	V	Voltage supplied to the input; device is "off"
Power Supply					
Voltage		5 3.0 to 6.5		V	Specifications
Current		50	65	mA	Operating
Current		85		mA	Operating Idle
Current			10	μA	At maximum output power
					Power Down

Pin	Function	Description	Interface Schematic
1	VCC2	Power supply for the driver stage and interstage matching. External matching on this pin is required to optimize the gain. The matching on this port also greatly affects the input impedance. A decoupling capacitor of 330 pF is required, together with a series RC for tuning for maximum gain at the desired frequency. See the application information for details.	
2	GND1	Ground connection for the driver stage. Keep traces physically short and connect immediately to the ground plane for best performance.	
3	PD	Power Down control. When this pin is "low", all circuits are shut off. A "low" is typical 1.2V or less at room temperature. When this pin is "high", all circuits are operating normally. A "high" is V_{CC} . If PD is below V_{CC} , output power and performance will be degraded. This could be used to obtain some gain control, but results are not guaranteed.	
4	RF IN	RF Input. This is a 50Ω input, but the actual impedance depends on the matching provided on pin 1. An external DC blocking capacitor is required if this port is connected to a DC path to ground.	
5	GND2	Ground connection for the output stage. Keep traces physically short and connect immediately to the ground plane for best performance.	
6	RF OUT	RF Output and power supply for the output stage. Bias for the output stage needs to be provided on this pin. This can be done through a quarter-wave microstrip that is RF grounded on the other end. For matching to 50Ω, an external series microstrip line is required.	
7	RF OUT	Same as pin 6.	
8	VCC1	Power supply for the bias circuits. An external RF bypass capacitor of 22 pF is required. Keep the traces to the capacitor as short as possible, and connect the capacitor immediately to the ground plane.	
Pkg Base	GND	Ground connection. The backside of the package should be connected to the ground plane through a short path, i.e., vias under the device may be required.	

Application Schematic 2450MHz

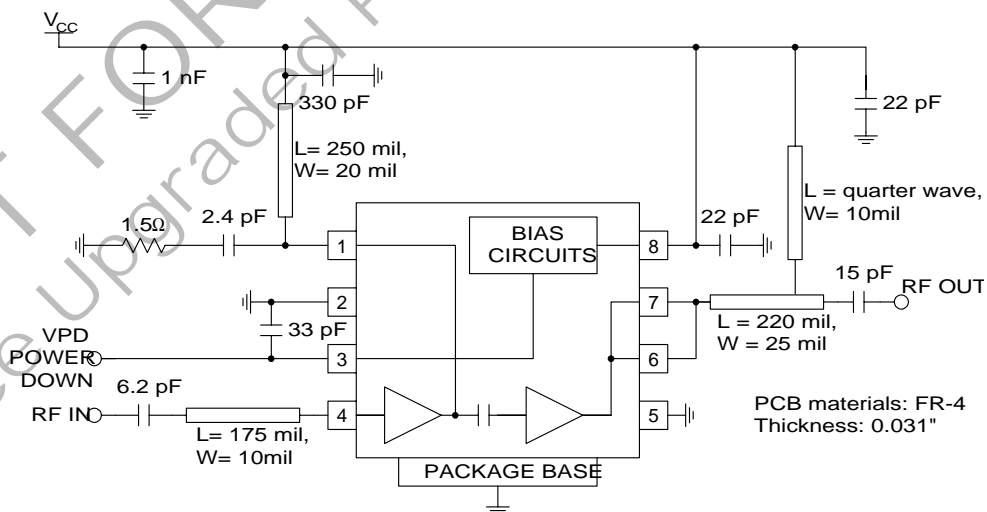

RF2128

Evaluation Board Schematic 2450MHz Operation

(Download [Bill of Materials](http://www.rfmd.com) from www.rfmd.com.)

2128400 Rev -

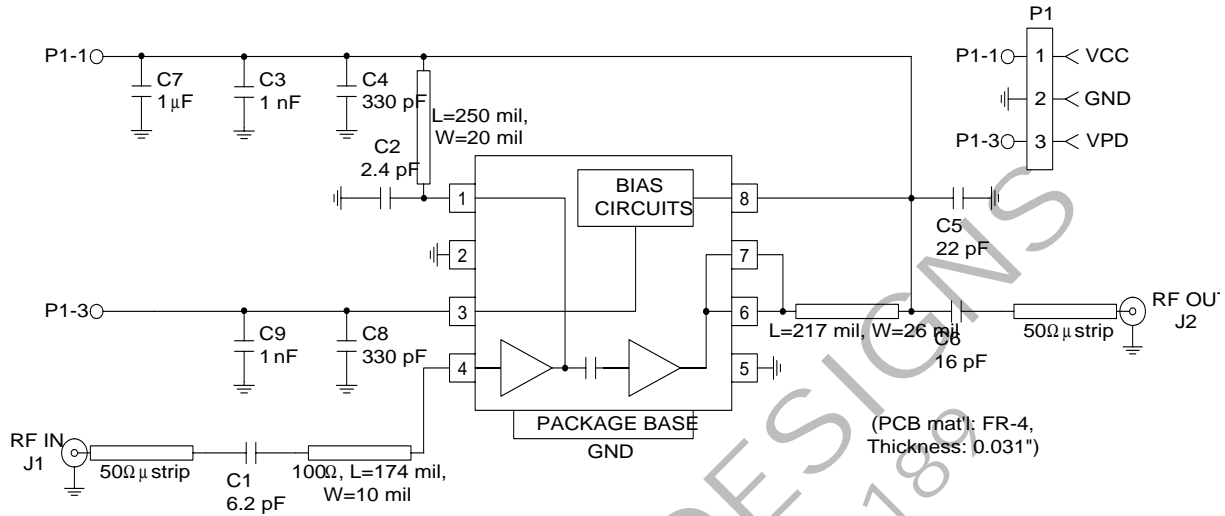

Evaluation Board Layout 1.547" x 1.068"

