

ASSP Power Supplies

BIPOLAR

Switching Regulator Controller

MB3782

DESCRIPTION

The FUJITSU MB3782 is a PWM-type switching regulator controller, designed with open-collector output for connection to external drive transistors and coils, providing a selection of three types of output voltage: step-up, step-down or inverting (inverting output is available on one circuit only).

The MB3782 features identical oscillator output waveforms to enable completely synchronous operation and prevent the occurrence of low-frequency beat between channels.

Also, the MB3782 features low power dissipation (2.1 mA Typ) and a built-in standby mode (10 μ A), making possible the configuration of a wide variety of high-efficiency, stable power supplies, even with the use of battery power. The MB3782 is an ideal power supply for high-performance portable devices such as video camcorders and cameras.

FEATURES

- Wide voltage range (3.6 V to 18 V)
- Low power dissipation (operating mode: 2.1 mA (Typ), standby mode: 10 μ A (Max))
- Wide range of oscillator frequencies, high-frequency capability (1 to 500 kHz)
- On-chip timer-latch type short detection circuit
- On-chip undervoltage lockout circuit
- On-chip 2.50 V reference voltage circuit (1.25 V output available at R_T pin)
- Dead time adjustment over full duty cycle range
- On-chip standby mode (power on/off function)

PACKAGE

Plastic DIP, 20 pin

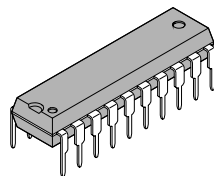

(DIP-20P-M01)

Plastic SOP, 20 pin

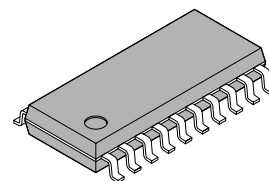

(FPT-20P-M01)

■ PIN ASSIGNMENT

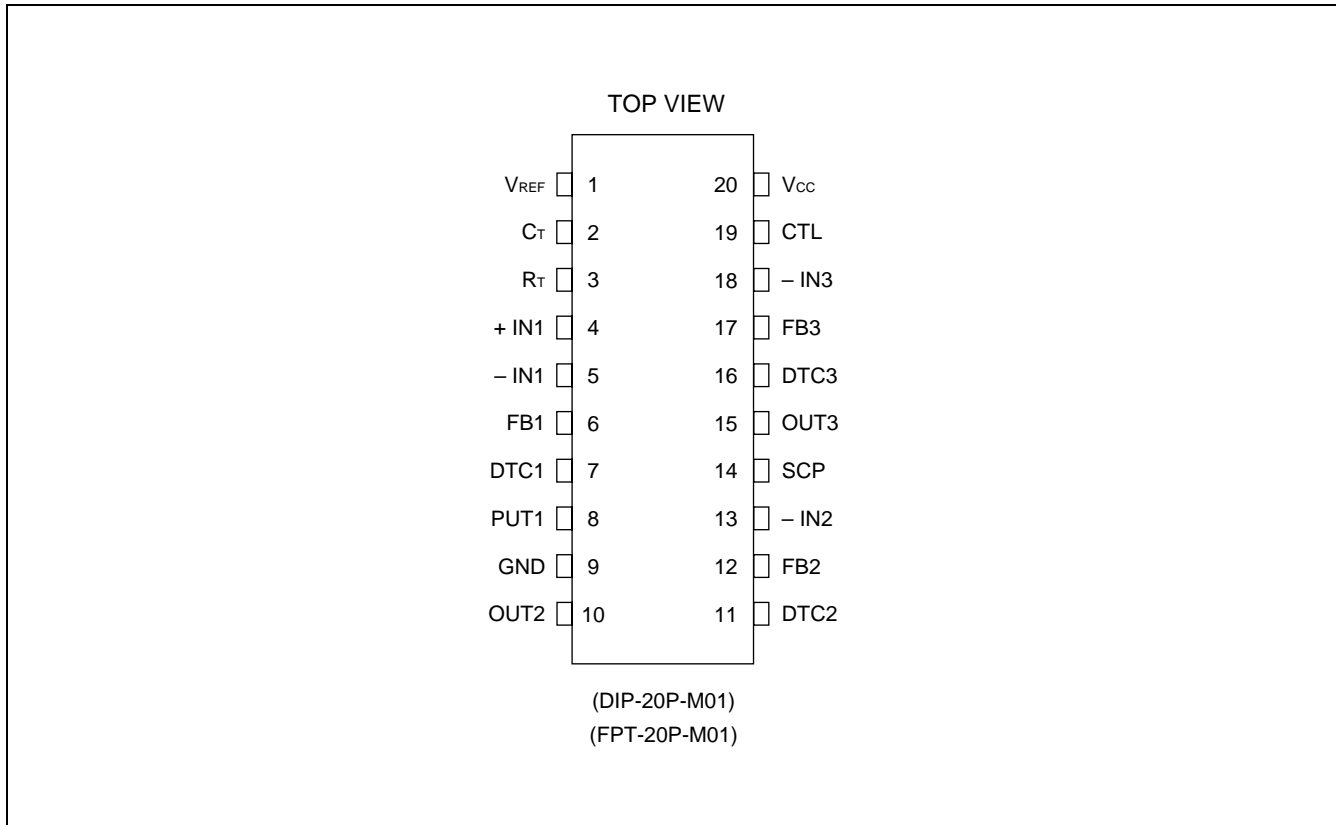

■ PIN DESCRIPTION

Pin No.	Pin Name	I/O	Description
1	V _{REF}	O	2.50 V (typ) voltage output: provides load current up to 3 mA, for use as error amplifier reference input and for dead time setting.
2	C _T	—	Oscillator timing capacity connection: should be used in the capacity range 150 to 15000 pF.
3	R _T	—	Oscillator timing resistor connection: should be used in the resistance range 5.1 to 100 kΩ. This pin can also provide output at voltage level V _{REF} /2, for use as error amplifier reference input.
4	+IN1	I	Error amplifier 1 non-inverting input pin.
5	-IN1	I	Error amplifier 1 inverting input pin.
6	FB1	O	Error amplifier 1 output pin: connect resistor and capacitor between this pin and the -IN1 pin to set gain and adjust frequency characteristics.
7	DTC1*1	I	OUT1 dead time setting pin: V _{REF} voltage is divided by an external resistor and applied to set dead time. Also, a capacitor may be connected between this pin and the GND pin to perform soft start operations.

(Continued)

(Continued)

Pin No.	Pin Name	I/O	Description
8	VOUT1	O	Open collector type output pin with an emitter connected to GND. Output current may be up to 50 mA.
9	GND	—	Ground pin
10	OUT2	O	Open collector type output pin with an emitter connected to GND. Output current may be up to 50 mA.
11	DTC2*1	I	Used to set OUT2 pin dead time. V_{REF} voltage is divided by an external resistor and applied to set dead time. Also, a capacitor may be connected between this pin and the GND pin to perform soft start operations.
12	FB2	O	Error amplifier 2 output pin: connect resistor and capacitor between this pin and the $-IN2$ pin to set gain and adjust frequency characteristics.
13	$-IN2$	I	Error amplifier 2 inverting input pin.
14	SCP*2	—	Time constant setting capacitor connection for timer-latch type short prevention circuit: a capacitor should be connected between this pin and the GND pin. For details, see "■ Setting the Time Constant for the Timer-Latch Type Short Prevention Circuit."
15	OUT3	O	Open collector type output pin for emitter connected to GND. Output current may be up to 50 mA.
16	DTC3*1	I	Used to set OUT3 pin dead time. V_{REF} voltage is divided by an external resistor and applied to set dead time. Also, a capacitor may be connected between this pin and the GND pin to perform soft start operations.
17	FB3	O	Error amplifier 3 output pin: connect resistor and capacitor between this pin and the $-IN3$ pin to set gain and adjust frequency characteristics.
18	$-IN3$	I	Error amplifier 3 inverting input pin.
19	CTL	I	Power supply control pin: low level places the IC in standby mode and reduces power consumption to 10 μ A or lower. Input level may be driven by TTL or CMOS.
20	V_{CC}	—	Power supply pin: voltage range is 3.6 to 18 V.

*1: DTC = Dead Time Control

*2: SCP = Short Circuit Protection

■ BLOCK DIAGRAM

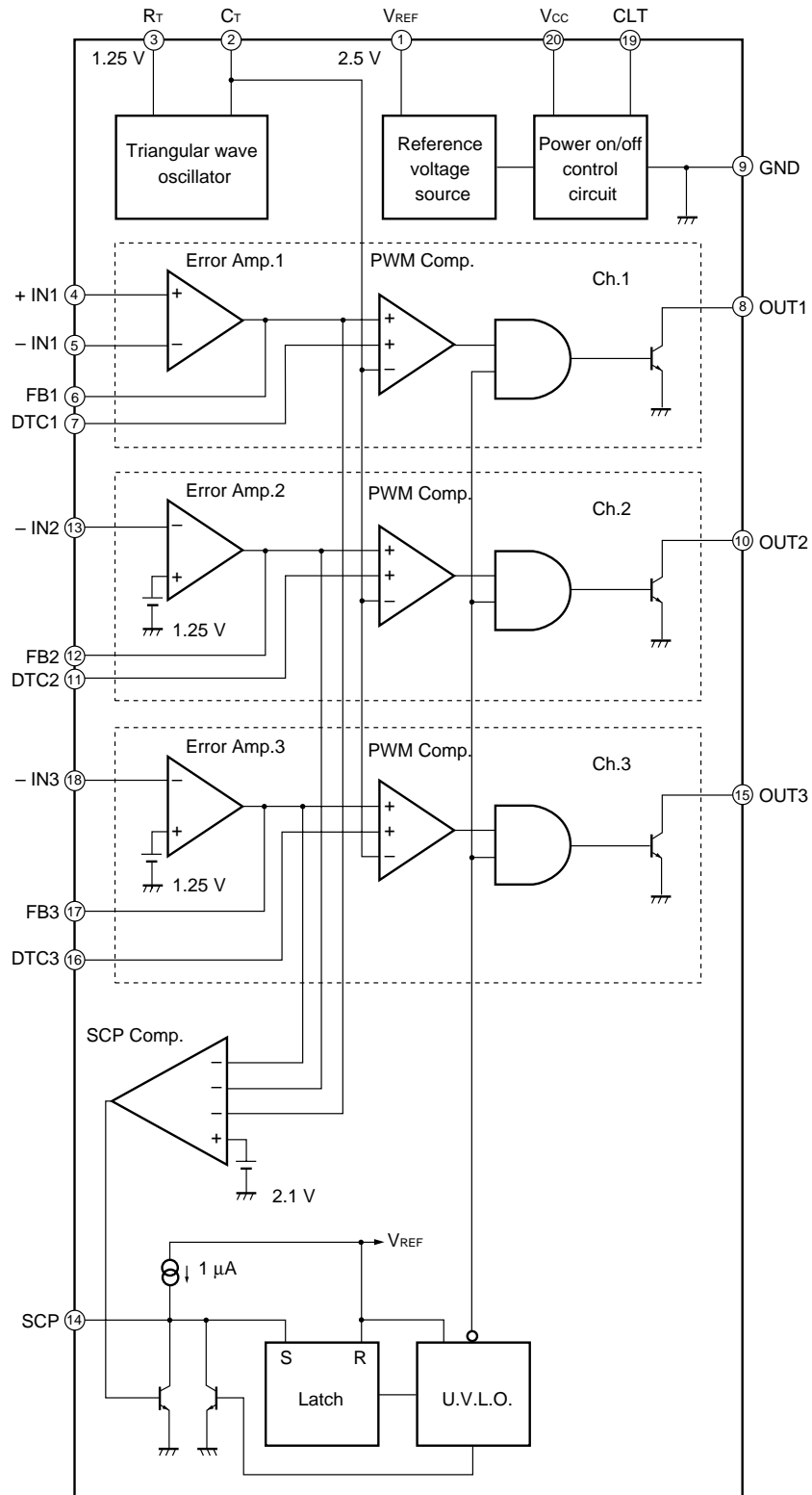

■ FUNCTIONAL DESCRIPTIONS

1. Reference Voltage Source

The reference voltage source uses the voltage provided at the power supply pin (pin 20) to generate a temperature-compensated reference voltage ($\cong 2.50$ V), which is used as the operating power supply for the internal circuits of the IC. The reference voltage source can be output through the V_{REF} pin (pin 1).

2. Triangular Wave Oscillator

By connecting a timing capacitor and resistor respectively to the C_T pin (pin 2) and R_T pin (pin 3), the oscillator can provide a triangular waveform at any desired frequency.

The waveform has an amplitude of 1.3 V to 1.9 V, and can be connected to the non-inverting input of the on-chip PWM comparator and also output through the C_T pin.

3. Error Amps

The error amps are amplifiers that detect the output voltage of the switching regulator and send the PWM control signal. The common-mode input voltage range is 1.05 V to 1.45 V, so that the voltage applied to the non-inverting input pin as a reference voltage should be either the voltage obtained by dividing the IC reference voltage output (recommended value: $V_{REF}/2$) or the voltage obtained from the R_T pin (1.25 V). The non-inverting input for the error amps 1 and 2 is internally connected to $V_{REF}/2$ voltage.

Also, a feedback transistor and capacitor can be connected between the error amp output pin and inverting input pin to provide any desired level of loop gain, enabling stable phase compensation.

4. Timer Latch (S-R Latch) Type Short Prevention Circuit

The timer-latch type short prevention circuit detects the output levels from each of the error amps. Whenever one or more error amps produces an output level of 2.1 V or higher, the timer circuit is activated starting the charging of the external protection enabler capacitor.

If the error amp output voltage does not return to normal range before the voltage in this capacitor reaches the transistor's base-emitter junction voltage ($V_{BE} \cong 0.65$ V), the latch circuit will operate to turn the output transistor off and at the same time set the dead time to 100%.

Once the prevention circuit is activated, the power must be switched on again to resume normal operation.

5. Low Input Voltage Fault Prevention Circuit (Under Voltage Lock-Out (UVLO) function)

When power is switched on, excess power or momentary drops in power line current can cause operating faults in the controller IC, which can in turn lead to damage or deterioration in systems.

The low input voltage fault prevention circuit detects the internal reference voltage level with respect to the power supply voltage level and acts to reset the latch circuit, thereby turning the output transistor off and at the same time setting the dead time to 100% and holding the SCP pin (pin 14) at "low." Operation returns to normal when the power supply voltage reaches or exceeds the UVLO threshold voltage level.

6. PWM Comparator

The PWM comparator is a voltage comparator with one inverting and two non-inverting inputs, which acts as a voltage to pulse width converter controlling the on-time of the output pulse according to the input voltage level. When the triangular waveform produced by the oscillator is lower than either the error amp output or the DTC pin voltage, the output transistor is switched on.

It is also possible to use the DTC terminal to provide a soft start function.

7. Output Transistor

The output is open-collector type, with the emitter of the output transistor connected to the GND pin. The power transistor for external switching can carry a base current of up to 50 mA.

8. Power Supply Control

Power supply on/off control is enabled through the CTL pin (pin 19). (In standby mode, power supply current is 10 μ A or less.)

■ SETTING THE TIME CONSTANT FOR THE TIMER-LATCH TYPE SHORT PREVENTION CIRCUIT

Figure 1 shows the configuration of the protection latch circuit.

The output lines from the error amps are each connected to the inverting input lines of the short protection comparator, which constantly compares them with the reference voltage of approximately 2.1 V connected to the non-inverting input.

When load conditions in the switching regulator are stabilized, there is no variation in the output from the error amps, and therefore the short prevention controls are held in equilibrium. In this situation, voltage at the SCP pin (pin 14) is held at approximately 50 mV.

When load conditions change rapidly, as in the case of a load short, high potential signal (greater than 2.1V) from the error amps is input to the inverting signal input of the short protection comparator, and the short protection comparator outputs a “low” level signal. The transistor Q1 is consequently switched off, so that short protection capacitor C_{PE} externally connected to the SCP pin voltage is then charged according to the following formulas.

$$V_{PE} = 50 \text{ mV} + t_{PE} \times 10^{-6}/C_{PE}$$

$$0.65 = 50 \text{ mV} + t_{PE} \times 10^{-6}/C_{PE}$$

$$C_{PE} = t_{PE}/0.6 (\mu\text{F})$$

When the short protection capacitor is charged to a level of approximately 0.65 V, the SR latch is set and the low input voltage fault prevention circuit is enabled, turning the output drive transistor off. At the same time, the dead time is set to 100% and the SCP pin (pin 14) is held “low.” This closes the S-R latch input and then discharges the capacitor C_{PE}

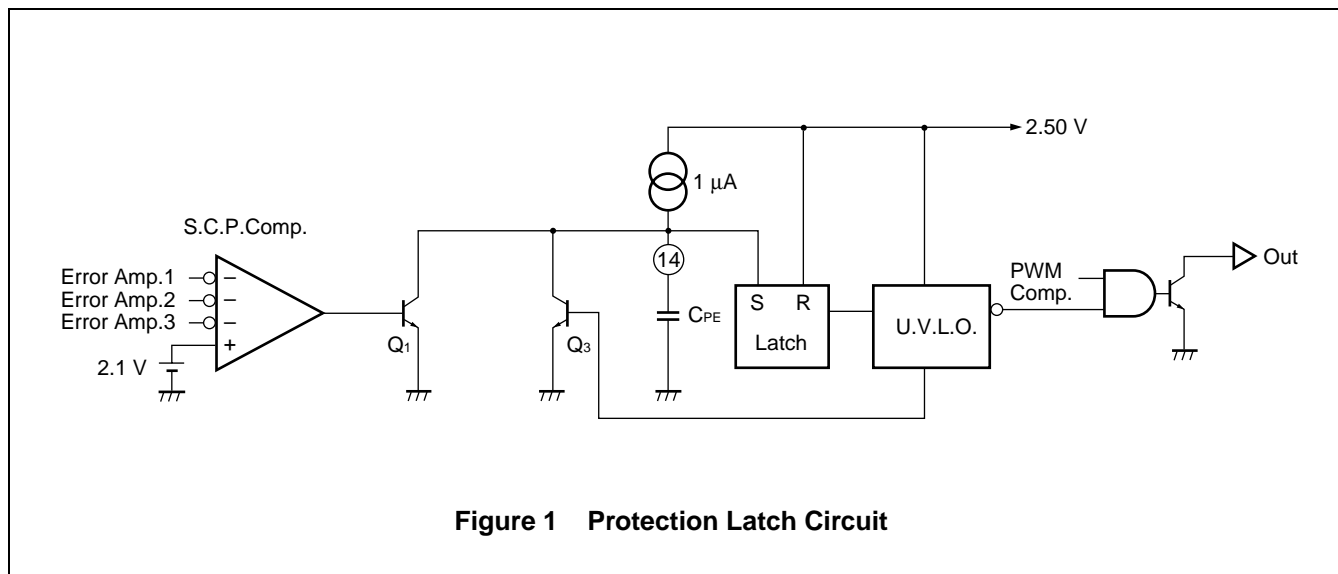

■ SETTING OUTPUT VOLTAGE

The following diagrams show the connections used to set the output voltage.

Because the power supply to the error amps is provided by the same reference voltage circuit used for the other internal circuits, the common-mode input voltage range is set at 1.05 V to 1.45 V.

The reference voltage input to the +IN and -IN pins should be set at 1.25 V ($V_{REF}/2$). The method of connection for channel 1 is different from channel 2 and channel 3. In addition, channel 1 is capable of picking up both positive and negative voltages, while channel 2 and channel 3 can pick up only positive output voltages.

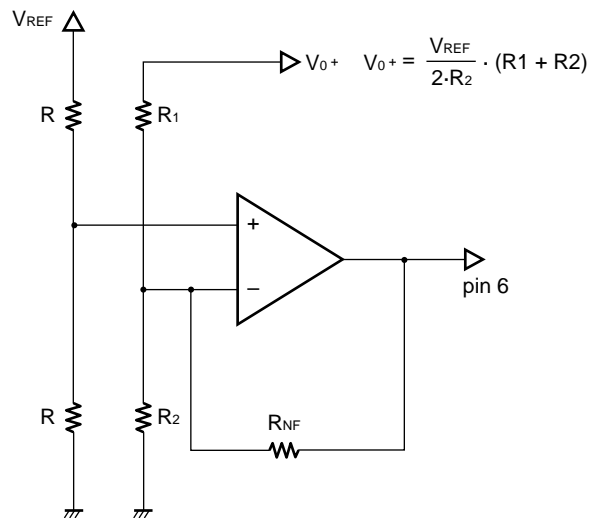

Figure 2 Error amp (channel 1) connection: Output voltage V_0 positive

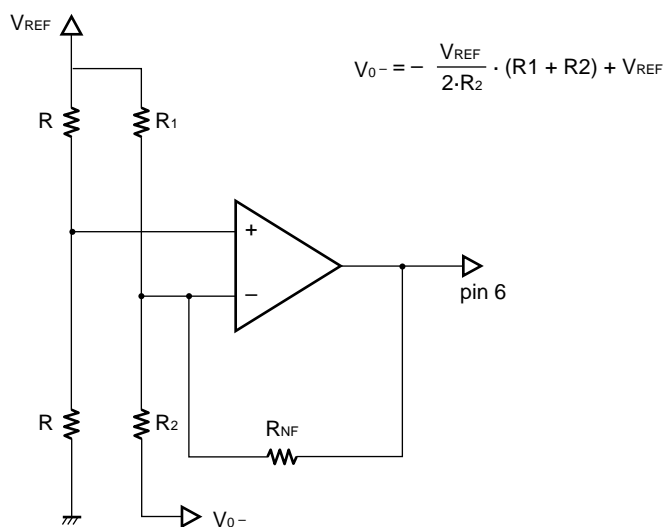
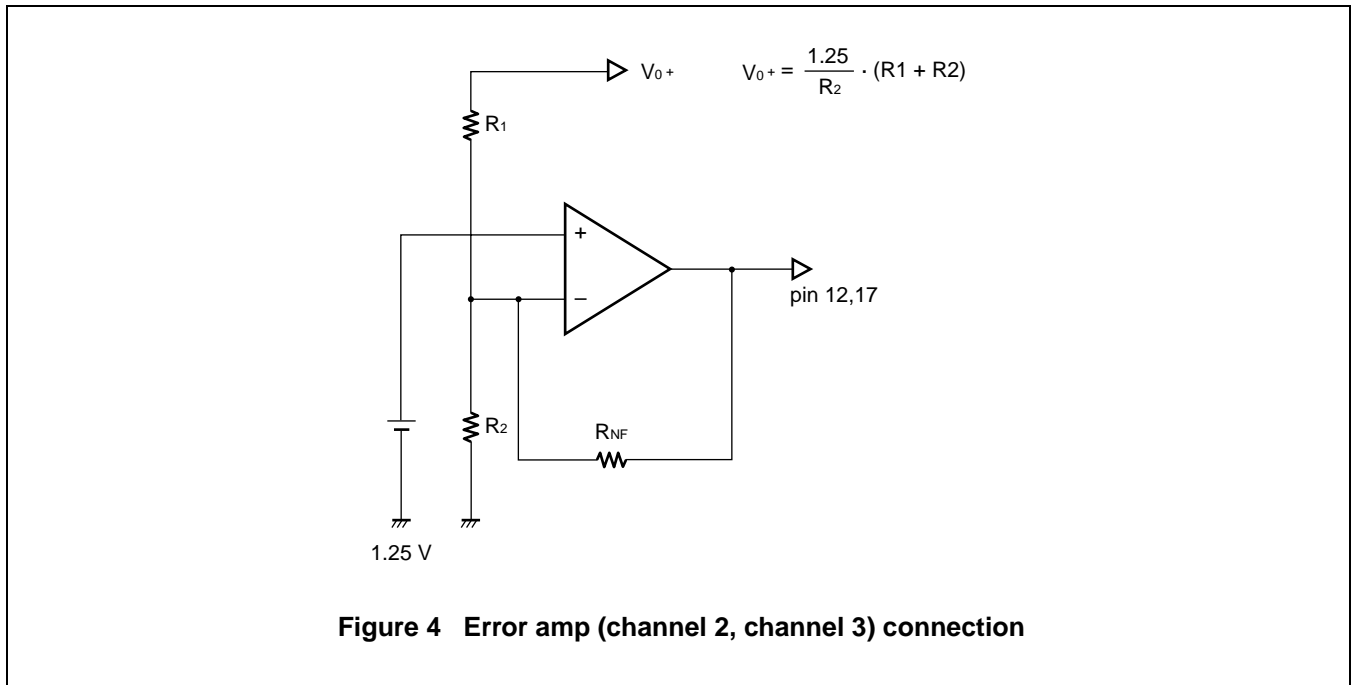

Figure 3 Error amp (channel 1) connection: Output voltage V_0 positive



The non-inverting input to the error amps on channel 2 and channel 3 is internally connected to $V_{REF}/2$, and therefore cannot be configured for inverting output.

	ch-1	ch-2	ch-3
Step up	●	●	●
Step down	●	●	●
Inverting	●	×	×

■ USING THE R_T PIN

The triangular waves, as shown in Figure 5, act to set the oscillator frequency by charging and discharging the capacitor connected to the C_T pin using the current value of the resistor connected to the R_T pin.

In addition, when voltage level $V_{REF}/2$ is output to external circuits from the R_T pin, care must be taken in making the external circuit connections to adjust for the fact that I_1 is increased by the value of the current I_2 to the external circuits in determining the oscillator frequency (see Figure 6).

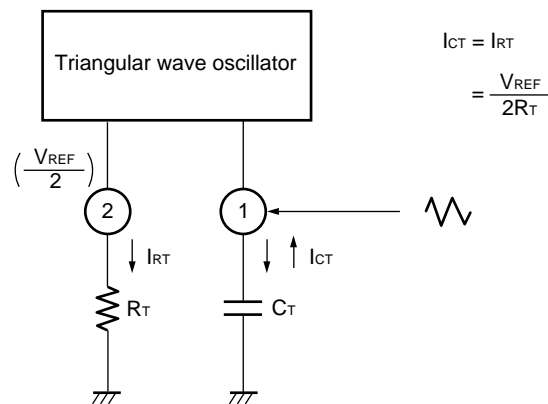

Figure 5 No $V_{REF}/2$ connection to external circuits from R_T pin

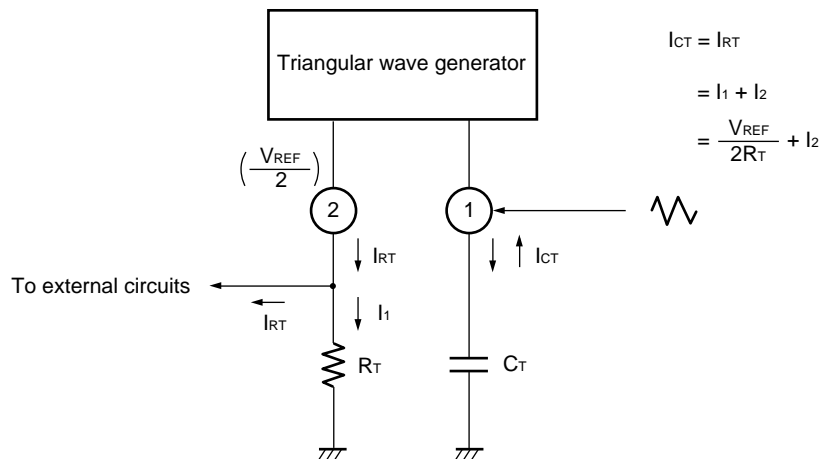

Figure 6 $V_{REF}/2$ connection to external circuits from R_T pin

■ TREATMENT OF UNUSED ERROR AMPS

Any error amps that are not used should be handled as follows.

Note that failure to apply proper treatment to error amps will cause the SCP circuit to activate and disable the switching regulator output.

1. Error Amp (channel 1) Not In Use

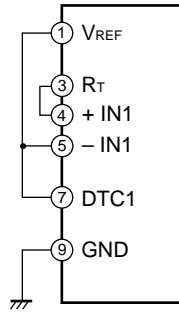

Note: Pin 6 and pin 8 should be left open.

2. Error Amp (channel 2) Not In Use

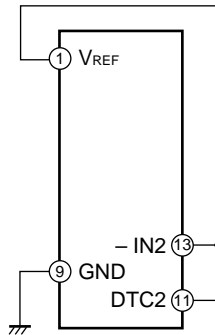

Note: Pin 10 and pin 12 should be left open.

3. Error Amp (channel 3) Not In Use

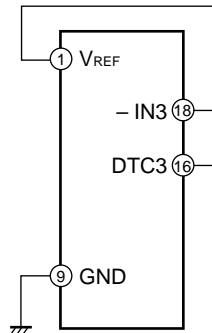

Note: Pin 15 and pin 17 should be left open.

■ TREATMENT OF UNUSED SCP PIN

When the timer latch short protection circuit is not used, the SCP pin should be connected to the GND by the shortest possible path.

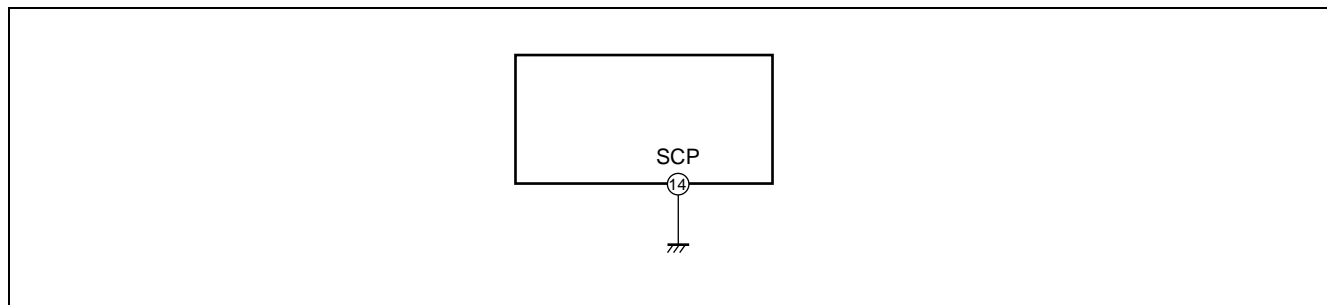

■ ABSOLUTE MAXIMUM RATINGS

(Ta = +25°C)

Parameter	Symbol	Condition	Rating		Unit	
			Min	Max		
Power supply voltage	V _{CC}	—	—	20	V	
Error amp input voltage	V _{IN}	—	-0.3	+10	V	
Dead time control input voltage	V _{dt}	—	-0.3	+2.8	V	
Control input voltage	V _{CTL}	—	-0.3	+20	V	
Collector output voltage	V _{OUT}	—	—	20	V	
Collector output current	I _{OUT}	—	—	75	mA	
Allowable loss	P _D *1	Ta ≤ +25°C	SOP Version	—	740*2	mW
			DIP Version	—	1110	
Operating temperature	Top	—	-30	+85	°C	
Storage temperature	Tstg	—	-55	+125	°C	

*1: For operation in conditions where Ta > +25°C, the SOP version should be derated by 7.4 mW/°C, and the DIP version should be derated by 11.1 mW/°C.

*2: When mounted on a 4 cm-square dual-sided epoxy board.

WARNING: Semiconductor devices can be permanently damaged by application of stress (voltage, current, temperature, etc.) in excess of absolute maximum ratings. Do not exceed these ratings.

■ RECOMMENDED OPERATING CONDITIONS

Parameter	Symbol	Condition	Value			Unit
			Min	Typ	Max	
Power supply voltage	V _{CC}	—	3.6	6.0	18.0	V
Error amp input voltage	V _{IN}	—	1.05	—	1.45	V
Control input voltage	V _{CTL}	—	0	—	18	V
Collector output voltage	V _{OUT}	—	—	—	18	V
Collector output current	I _{OUT}	—	0.3	—	50	mA
Reference voltage output current	I _{REF}	—	-3	-1	0	mA
Timing capacitance	C _T	—	150	—	15000	pF
Timing resistance	R _T	—	5.1	—	100	kΩ
Oscillator frequency	f _{osc}	—	1	—	500	kHz
Operating temperature	Top	—	-30	+25	85	°C

WARNING: The recommended operating conditions are required in order to ensure the normal operation of the semiconductor device. All of the device's electrical characteristics are warranted when the device is operated within these ranges.

Always use semiconductor devices within their recommended operating condition ranges. Operation outside these ranges may adversely affect reliability and could result in device failure.

No warranty is made with respect to uses, operating conditions, or combinations not represented on the data sheet. Users considering application outside the listed conditions are advised to contact their FUJITSU representatives beforehand.

■ ELECTRICAL CHARACTERISTICS

(V_{CC} = 6 V, T_a = +25°C)

	Parameter	Symbol	Conditions	Value			Unit
				Min	Typ	Max	
Reference voltage	Output voltage	V _{REF}	I _{OR} = -1 mA	2.45	2.50	2.55	V
	Output voltage temperature variation	V _{RTC}	T _a = -30°C to +85°C	-2	±0.2	2	%
	Input stability	Line	V _{CC} = 3.6 V to 18 V	—	2	10	mV
	Load stability	Load	I _{OR} = -0.1 mA to -1 mA	—	1	7.5	mV
	Short output current	I _{OS}	V _{REF} = 2 V	-30	-10	-3	mA
Undervoltage lock out circuit (UVLO)	Threshold voltage	V _{TH}	I _{OR} = -0.1 mA	—	2.72	—	V
		V _{TL}	I _{OR} = -0.1 mA	—	2.60	—	V
	Hysteresis width	V _{HYS}	I _{OR} = -0.1 mA	80	120	—	mV
	Reset voltage (V _{CC})	V _R	—	1.5	1.9	—	V
Short circuit protection (SCP)	Input threshold voltage	V _{IPC}	—	0.60	0.65	0.70	V
	Input standby voltage	V _{STB}	No pull-up	—	50	100	mV
	Input latch voltage	V _{IN}	No pull-up	—	50	100	mV
	Input source current	I _{bpc}	—	-1.4	-1.0	-0.6	μA
	Comparator threshold voltage	V _{TC}	Pin 6, pin 12, pin 17	—	2.1	—	V
Triangular wave oscillator	Oscillator frequency	f _{OSC}	C _T = 330 pF, R _T = 15 kΩ	160	200	240	kHz
	Frequency deviation	f _{dev}	C _T = 330 pF, R _T = 15 kΩ	—	±5	—	%
	Frequency deviation (V _{CC})	f _{dV}	V _{CC} = 3.6 V to 18 V	—	±1	—	%
	Frequency deviation (T _a)	f _{dT}	T _a = -30°C to +85°C	-4	—	+4	%
Dead time controller (DTC)	Input threshold voltage	V _{t0}	Duty cycle = 0 %	1.05	1.3	—	V
		V _{t100}	Duty cycle = 100 %	—	1.9	2.25	V
	ON duty cycle	D _{tr}	V _{dt} = V _R /1.45 V	55	65	75	%
	Input bias current	I _{bdT}	—	—	0.2	1	μA
	Latch mode sink current	I _{dt}	V _{dt} = 2.5 V	150	500	—	μA
	Latch input voltage	V _{dt}	I _{dt} = 100 μA	—	—	0.3	V

(Continued)

MB3782

(Continued)

($V_{CC} = 6\text{ V}$, $T_a = +25^\circ\text{C}$)

	Parameter	Symbol	Conditions	Value			Unit
				Min	Typ	Max	
Error amps	Input offset voltage	V_{IO}	$V_{OUT} = 1.6\text{ V}$	-6	—	6	mV
	Input offset current	I_{IO}	$V_{OUT} = 1.6\text{ V}$	-100	—	100	nA
	Input bias current	I_B	$V_{OUT} = 1.6\text{ V}$	-500	-100	—	nA
	Common mode input voltage range	V_{ICR}	$V_{CC} = 3.6\text{ V to }18\text{ V}$	1.05	—	1.45	V
	Voltage gain	A_v	—	70	80	—	dB
	Frequency bandwidth	BW	$A_v = 0\text{ dB}$	—	0.8	—	MHz
	Common mode rejection ratio	CMRR	—	60	80	—	dB
	Maximum output voltage range	V_{OM+}	—	$V_{REF} - 0.3$	—	—	V
		V_{OM-}	—	—	0.7	0.9	V
	Output sink current	I_{OM+}	$V_{OUT} = 1.6\text{ V}$	—	1.0	—	mA
Output source current	I_{OM-}	$V_{OUT} = 1.6\text{ V}$	—	-60	—	μA	
PWM comparator	Input threshold voltage	V_{t0}	Duty cycle = 0 %	1.05	1.3	—	V
		V_{t100}	Duty cycle = 100 %	—	1.9	2.25	V
	Input sink current	I_{IN+}	Pin 6, pin 12, pin 17	—	1.0	—	mA
	Input source current	I_{IN-}	Pin 6, pin 12, pin 17	—	-60	—	μA
Control block	Input OFF conditions	V_{OFF}	—	—	—	0.7	V
	Input ON conditions	V_{ON}	—	2.1	—	—	V
	Control pin current	I_{CTL}	$V_{CTL} = 10\text{ V}$	—	200	400	μA
Output block	Output leak current	Leak	$V_{OUT} = 18\text{ V}$	—	—	10	μA
	Output saturation voltage	V_{SAT}	$I_{OUT} = 50\text{ mA}$	—	1.1	1.4	V
Entire device	Standby current	I_{CCS}	$V_{CTL} = 0\text{ V}$	—	—	10	μA
	Average feed current	I_{CCa}	$V_{CTL} = V_{CC}$, no output load	—	2.1	3.2	mA

- Notes :
- Voltage control on channel 1 may be positive or negative.
 - The non-inverting input to the error amps on channel 2 and channel 3 is internally connected to $V_{REF}/2$, and therefore voltage control is positive only.
 - $V_{REF}/2$ output can be obtained from the R_T pin.

■ TEST CIRCUIT

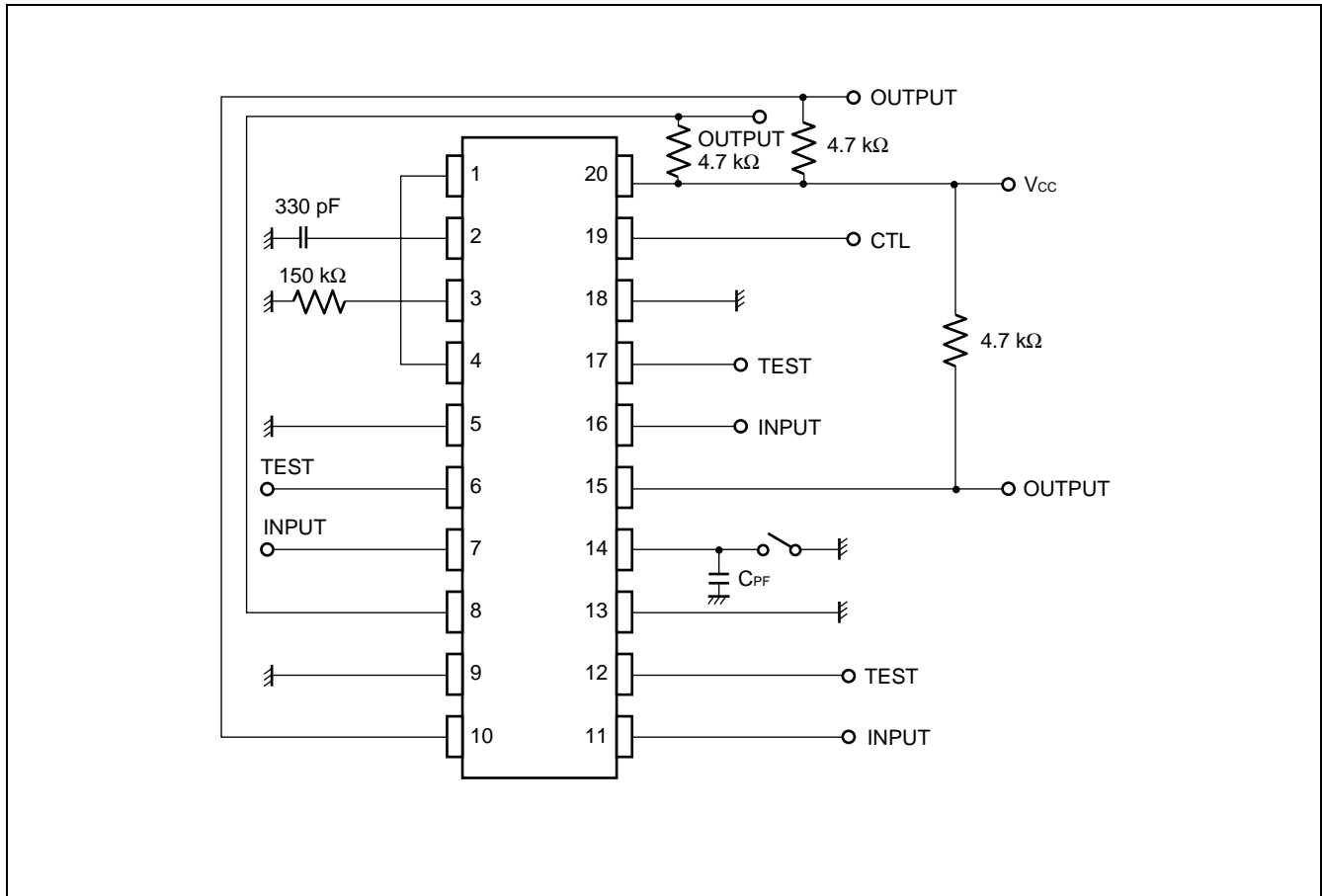

■ TIMING CHART (INTERNAL WAVEFORMS)

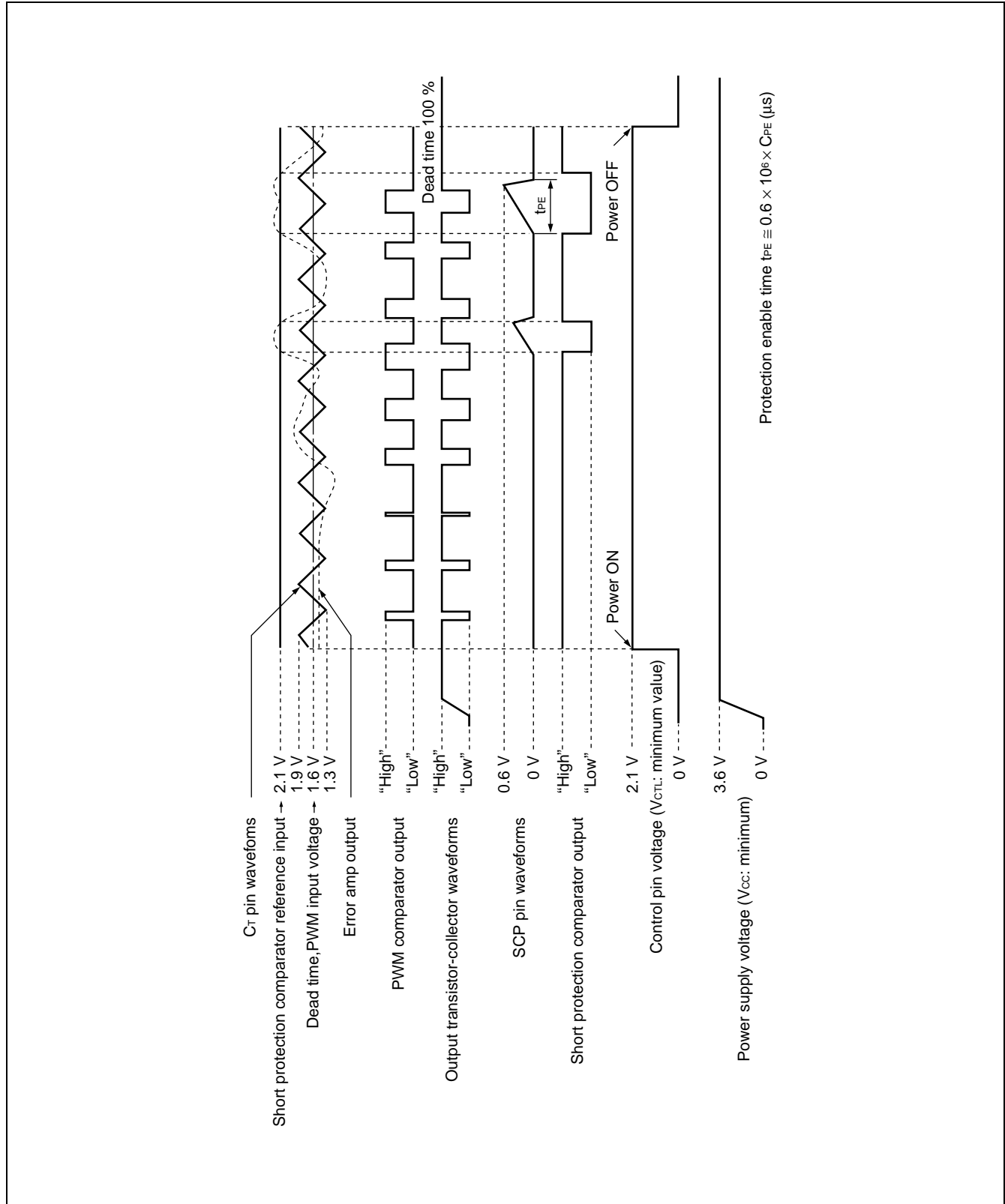

EXAMPLE OF APPLICATION

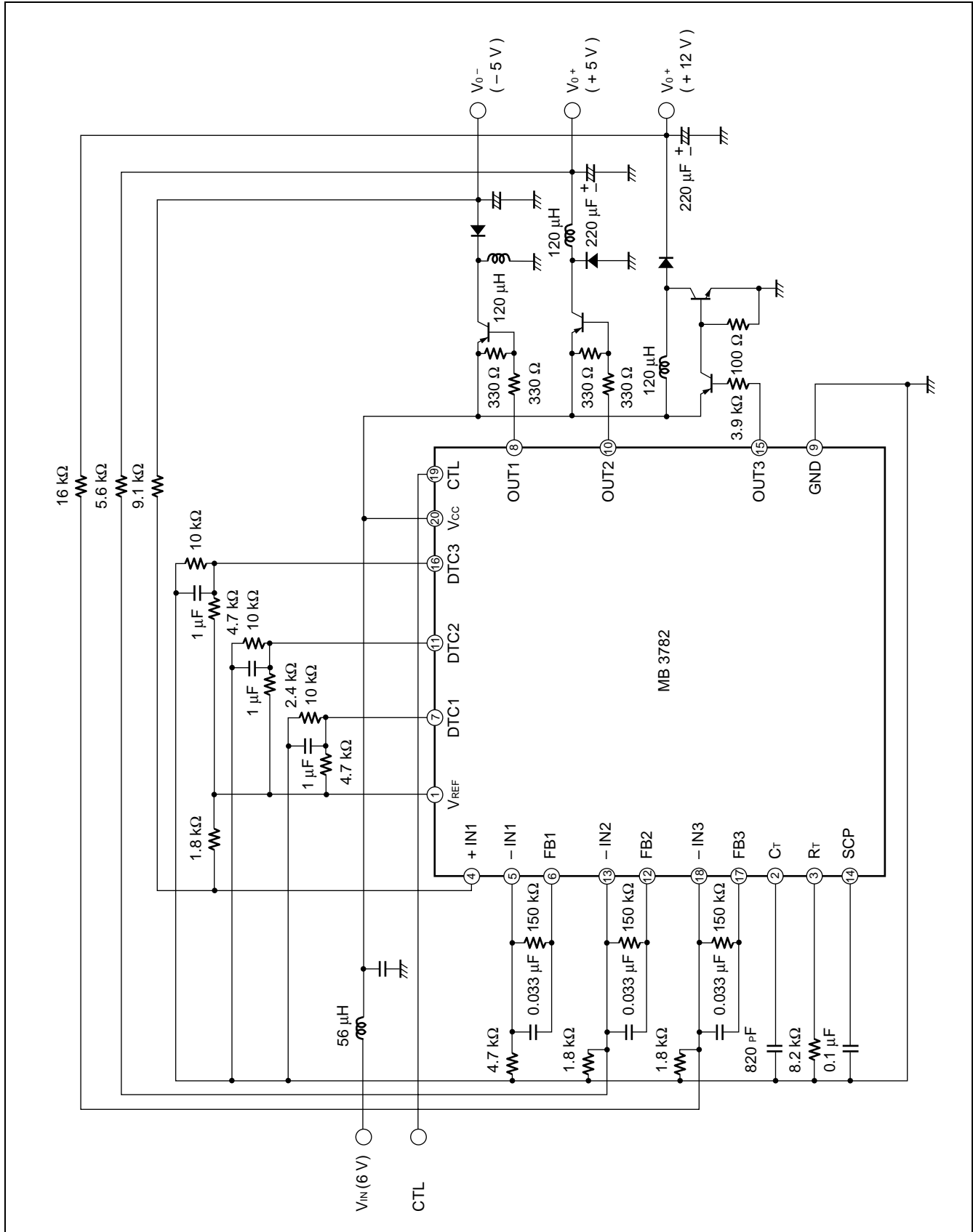

TYPICAL CHARACTERISTICS CURVES

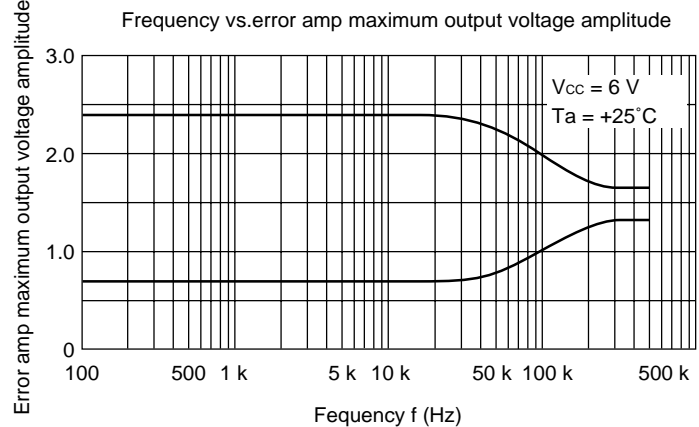
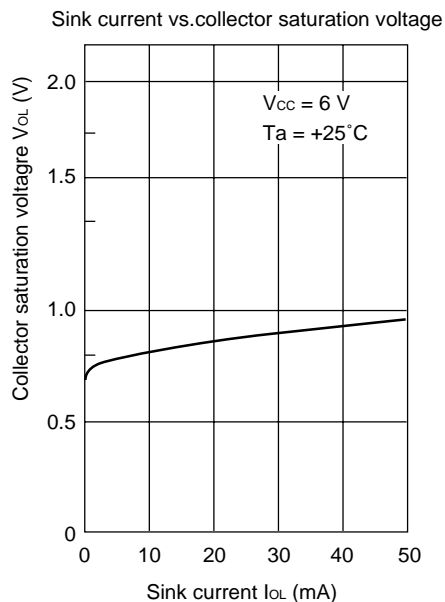
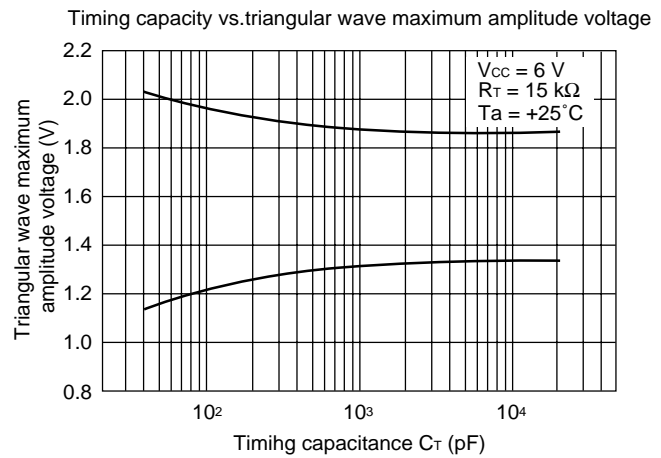
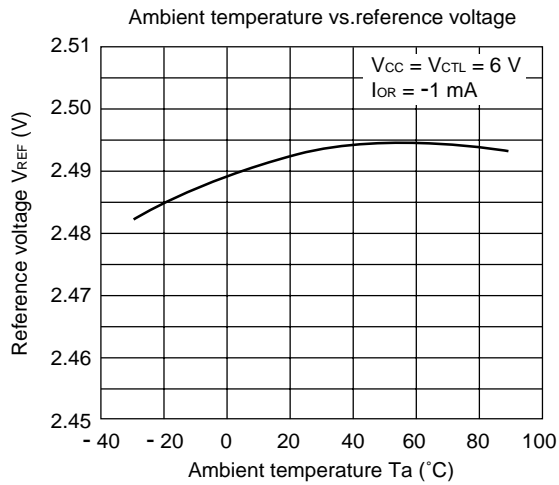
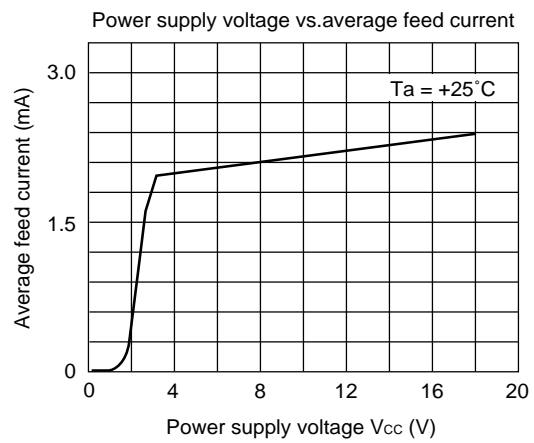
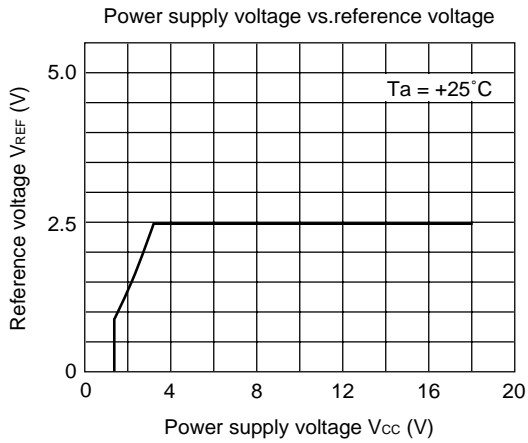

(Continued)

Timing resistance vs. oscillator frequency

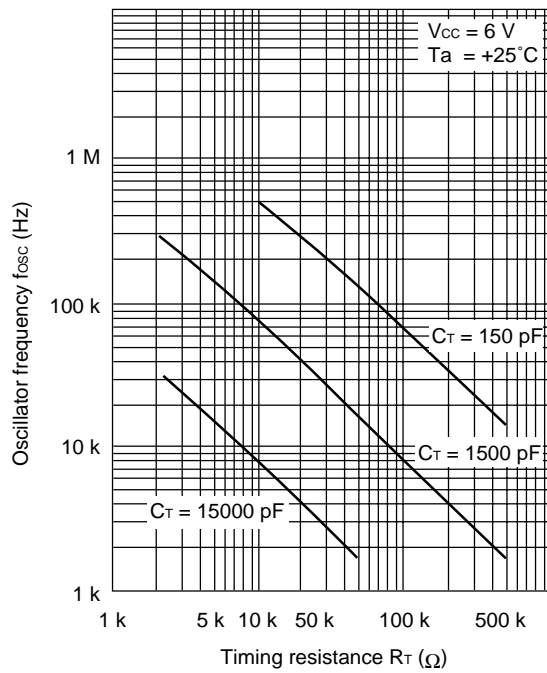

Power supply voltage vs. triangular wave period

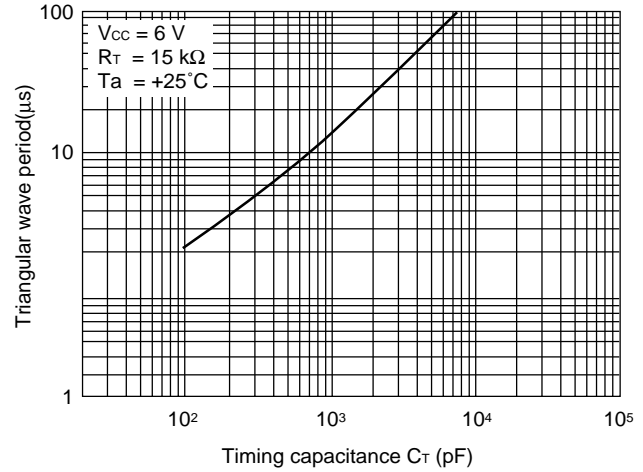

Ambient temperature vs. oscillator frequency

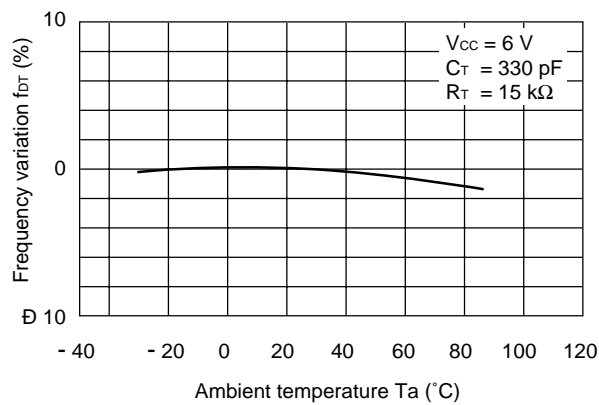

Oscillator frequency vs. duty cycle

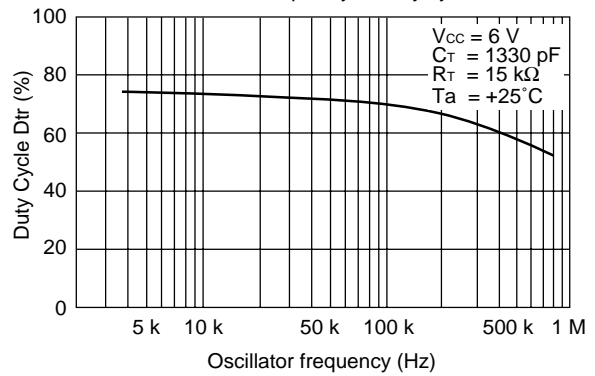

Control voltage vs. reference voltage

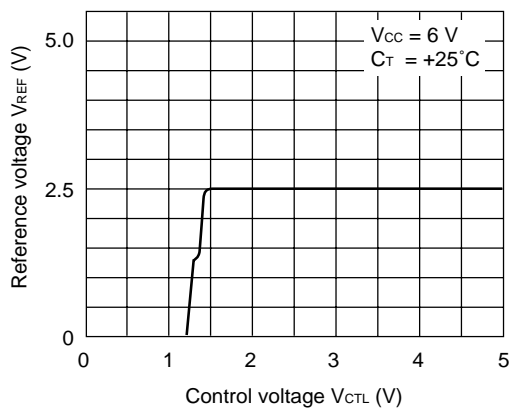

Control input current

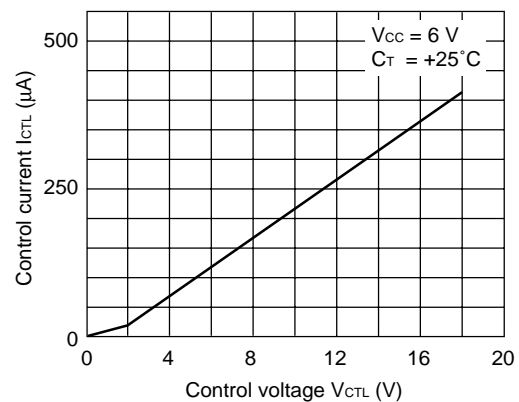

(Continued)

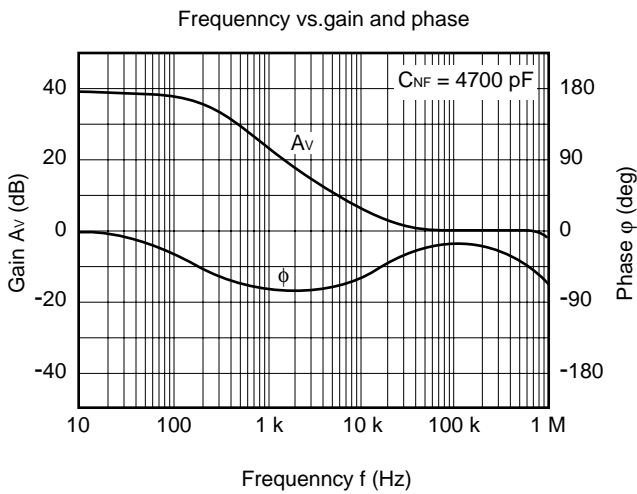
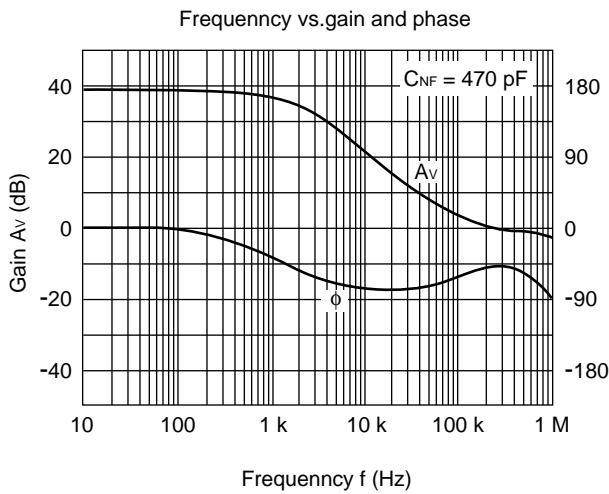
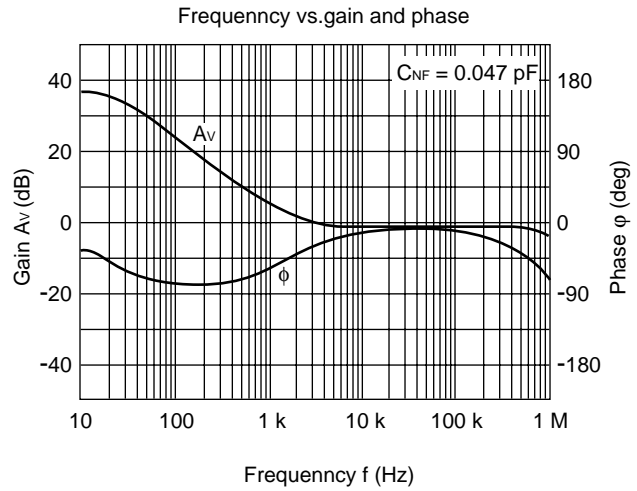
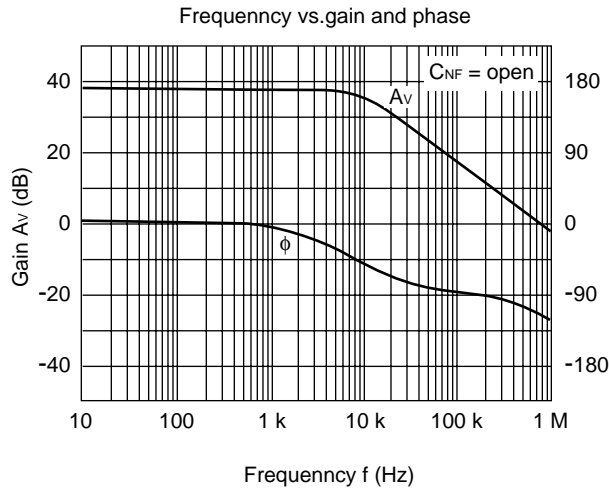

Test Circuit

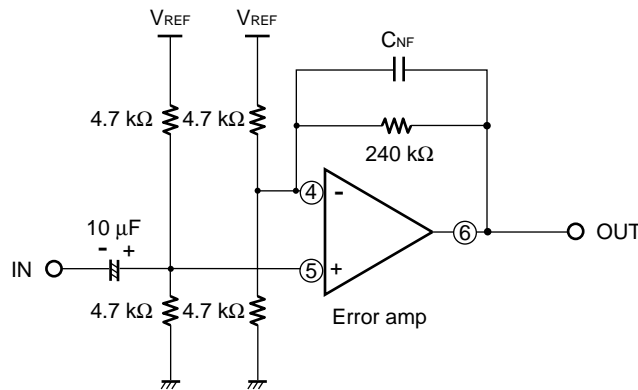

(Continued)

(Continued)

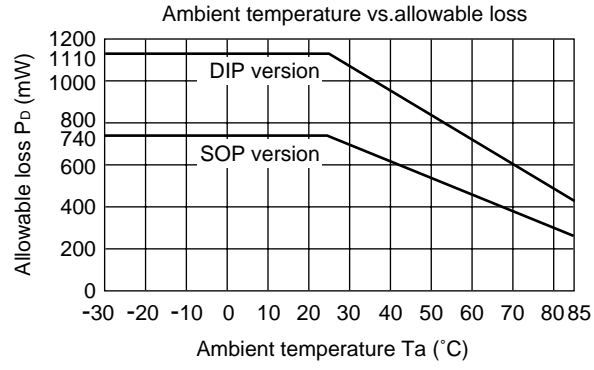

■ APPLICATIONS

• Concerning Equivalent Series Resistance and Stability of Smoothing Capacitors

In DC/DC converters, the equivalent series resistance value (ESR) of smoothing capacitors has a major influence on loop phase characteristics.

The ESR is a means by which phase characteristics approximate phase relationships to ideal capacitors in high-frequency bands (see Graph 1), thus improving system stability. At the same time, the use of smoothing capacitors with low ESR reduces system stability, so that care must be taken when using semiconductor electrolytic capacitors (OS capacitors) or tantalum capacitors with low ESR.

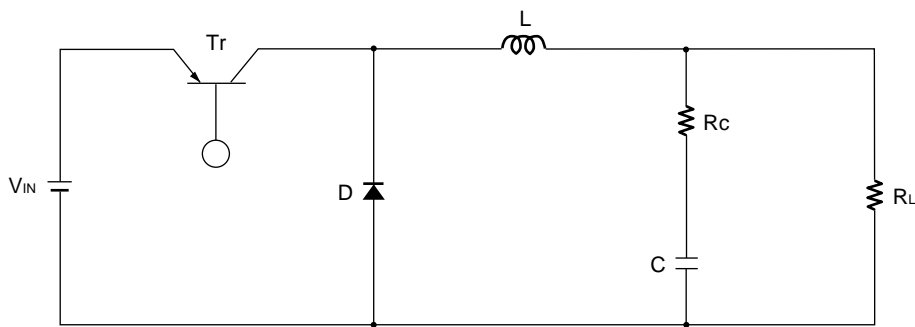
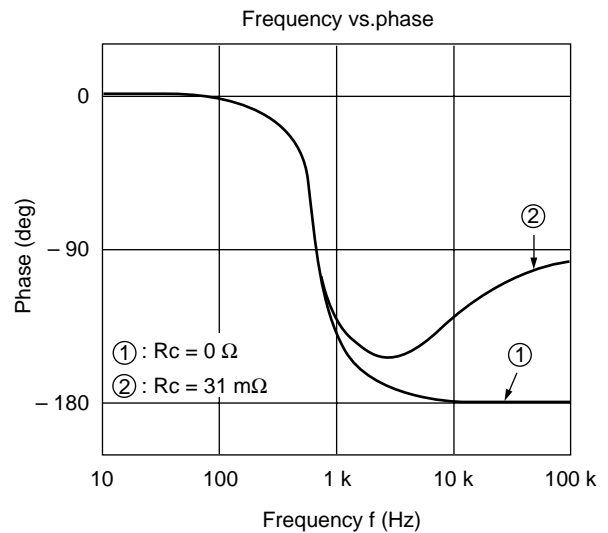
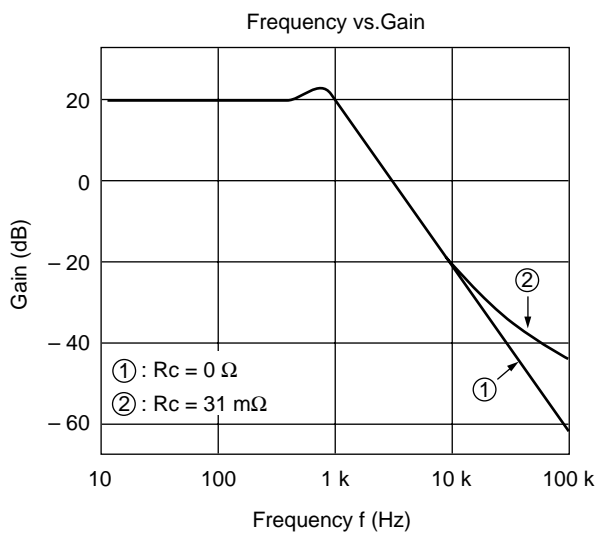

Figure 7 Basic circuit for step-down voltage DC/DC converter



Graph 1 Frequency vs. gain and phase

• Reference data

Changing the smoothing capacitor from an aluminum electrolytic capacitor ($RC \cong 1.0\Omega$) to a lower-ESR semiconductor electrolytic capacitor (OS capacitor: $RC \cong 0.2\Omega$) decreases the phase margin (see Graphs 2, 3).

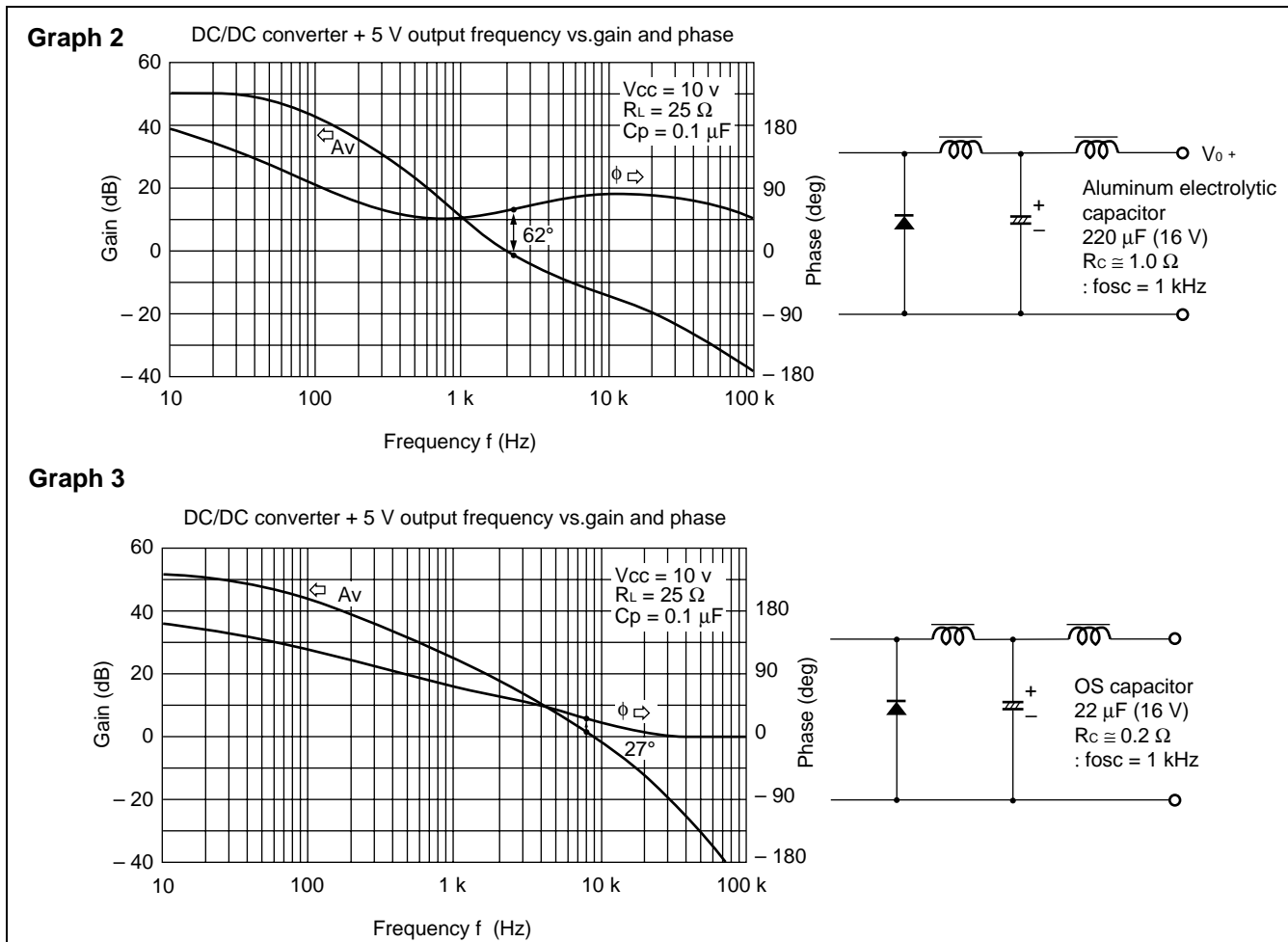
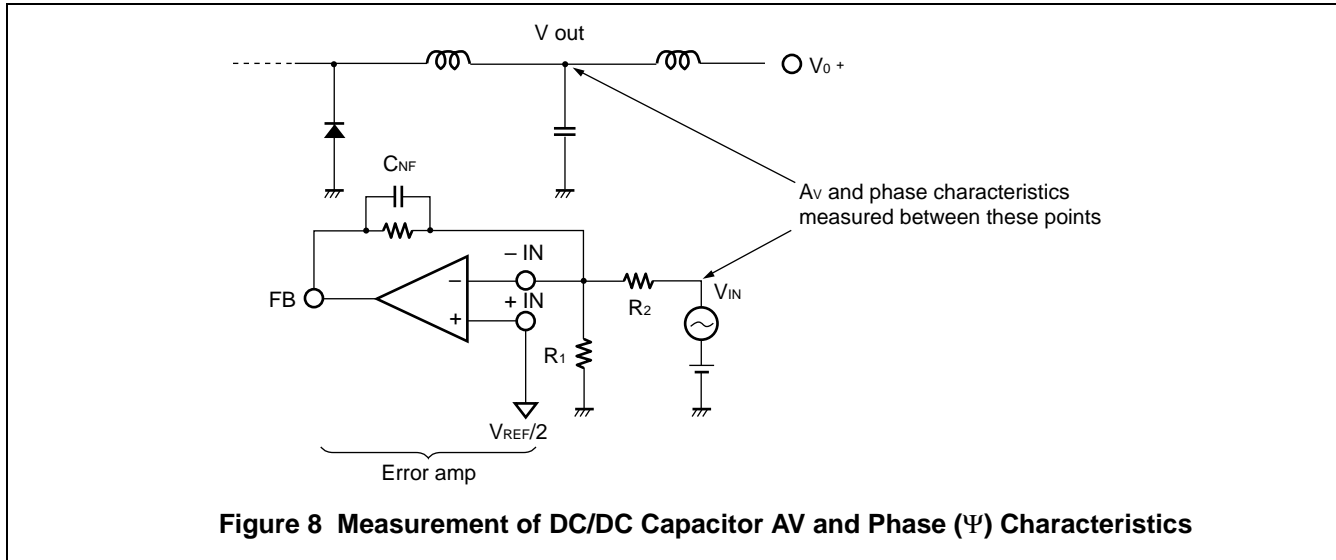

MB3782

■ NOTES ON USE

- Take account of common impedance when designing the earth line on a printed wiring board.
- Take measures against static electricity.
 - For semiconductors, use antistatic or conductive containers.
 - When storing or carrying a printed circuit board after chip mounting, put it in a conductive bag or container.
 - The work table, tools and measuring instruments must be grounded.
 - The worker must put on a grounding device containing 250 kΩ to 1 MΩ resistors in series.
- Do not apply a negative voltage
 - Applying a negative voltage of -0.3 V or less to an LSI may generate a parasitic transistor, resulting in malfunction.

■ ORDERING INFORMATION

Part number	Package	Remarks
MB3782P	Plastic DIP, 20 pin (DIP-20P-M01)	
MB3782PF	Plastic SOP, 20 pin (FPT-20P-M01)	

■ PACKAGE DIMENSIONS

Plastic DIP, 20 pin
(DIP-20P-M01)

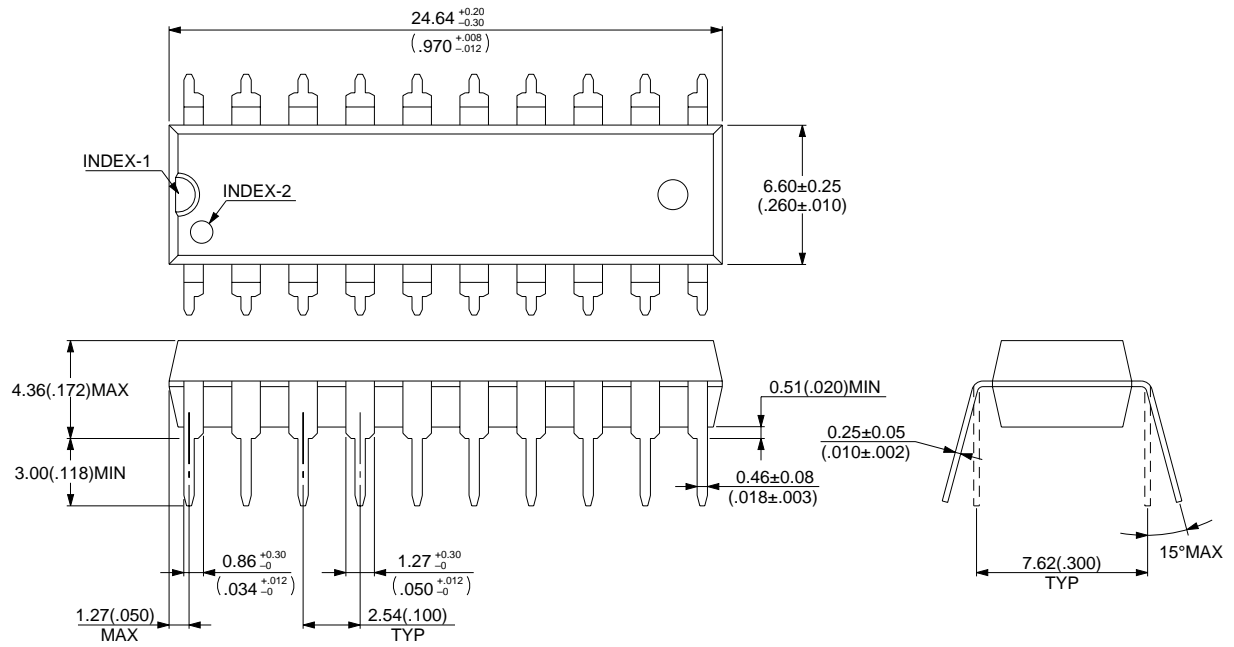

© 1994 FUJITSU LIMITED D20005S-3C-3

Dimensions in mm (inches) .

Note : The values in parentheses are reference values.

(Continued)

MB3782

(Continued)

Plastic SOP 20 pin
(FPT-20P-M01)

- Note 1) *1 : These dimensions include resin protrusion.
- Note 2) *2 : These dimensions do not include resin protrusion.
- Note 3) Pins width and pins thickness include plating thickness.
- Note 4) Pins width do not include tie bar cutting remainder.

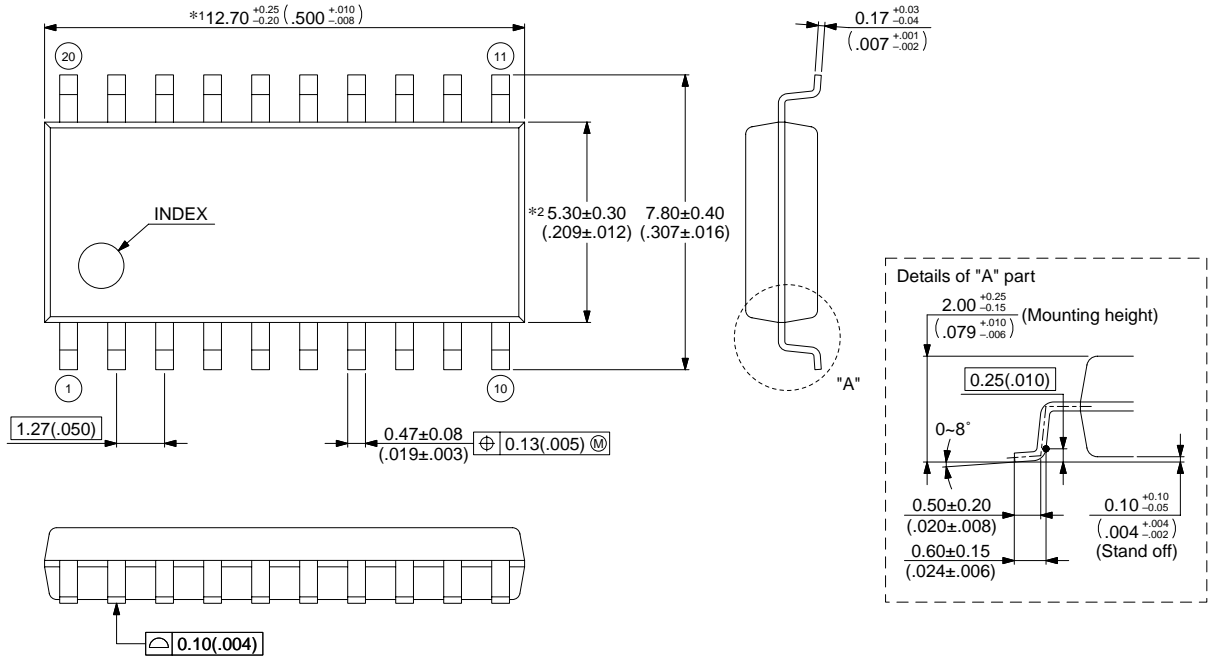

© 2002 FUJITSU LIMITED F20003S-c-7-7

Dimensions in mm (inches) .

Note : The values in parentheses are reference values.

FUJITSU LIMITED

All Rights Reserved.

The contents of this document are subject to change without notice. Customers are advised to consult with FUJITSU sales representatives before ordering.

The information, such as descriptions of function and application circuit examples, in this document are presented solely for the purpose of reference to show examples of operations and uses of Fujitsu semiconductor device; Fujitsu does not warrant proper operation of the device with respect to use based on such information. When you develop equipment incorporating the device based on such information, you must assume any responsibility arising out of such use of the information. Fujitsu assumes no liability for any damages whatsoever arising out of the use of the information.

Any information in this document, including descriptions of function and schematic diagrams, shall not be construed as license of the use or exercise of any intellectual property right, such as patent right or copyright, or any other right of Fujitsu or any third party or does Fujitsu warrant non-infringement of any third-party's intellectual property right or other right by using such information. Fujitsu assumes no liability for any infringement of the intellectual property rights or other rights of third parties which would result from the use of information contained herein.

The products described in this document are designed, developed and manufactured as contemplated for general use, including without limitation, ordinary industrial use, general office use, personal use, and household use, but are not designed, developed and manufactured as contemplated (1) for use accompanying fatal risks or dangers that, unless extremely high safety is secured, could have a serious effect to the public, and could lead directly to death, personal injury, severe physical damage or other loss (i.e., nuclear reaction control in nuclear facility, aircraft flight control, air traffic control, mass transport control, medical life support system, missile launch control in weapon system), or (2) for use requiring extremely high reliability (i.e., submersible repeater and artificial satellite).

Please note that Fujitsu will not be liable against you and/or any third party for any claims or damages arising in connection with above-mentioned uses of the products.

Any semiconductor devices have an inherent chance of failure. You must protect against injury, damage or loss from such failures by incorporating safety design measures into your facility and equipment such as redundancy, fire protection, and prevention of over-current levels and other abnormal operating conditions.

If any products described in this document represent goods or technologies subject to certain restrictions on export under the Foreign Exchange and Foreign Trade Law of Japan, the prior authorization by Japanese government will be required for export of those products from Japan.