

Product Preview

1:10 LVCMOS Zero Delay Clock Buffer

The MPC9608 is a 2.5V and 3.3V compatible, 1:10 PLL based zero-delay buffer. With a very wide frequency range and low output skews the MPC9608 is targeted for high performance and mid-range clock tree designs.

Features

- 1:10 outputs LVCMOS zero-delay buffer
- Single 3.3V or 2.5V supply
- 150 ps maximum output skew¹
- ± 100 ps static phase offset (SPO)¹
- Supports a clock I/O frequency range of 12.5 to 200 MHz
- Selectable divide-by-two for one output bank
- Synchronous output enable control (CLK_STOP)
- Output tristate control (output high impedance)
- PLL bypass mode for low frequency system test purpose
- Supports networking, telecommunications and computer applications
- Supports a variety of microprocessors and controllers
- Compatible to PowerQuicc I and II
- Ambient Temperature Range -40°C to $+85^{\circ}\text{C}$

Functional Description

The MPC9608 uses an internal PLL and an external feedback path to lock its low-skew clock output phase to the reference clock phase, providing virtually zero propagation delay. This enables nested clock designs with near-zero insertion delay. Designs using the MPC9608 as PLL fanout buffer will show significantly lower clock skew than clock distributions developed from traditional fanout buffers. The device offers one reference clock input and two banks of 5 outputs for clock fanout. The input frequency and phase is reproduced by the PLL and provided at the outputs. A selectable frequency divider sets the bank B outputs to generate either an identical copy of the bank A clocks or one half of the bank A clock frequency. Both output banks remain synchronized to the input reference for both bank B configurations.

Outputs are only disabled or enabled when the outputs are already in logic low state (CLK_STOP). For system test and diagnosis, the MPC9608 outputs can also be set to high-impedance state by connecting OE to logic high level. Additionally, the device provides a PLL bypass mode for low frequency test purpose. In PLL bypass mode, the minimum frequency and static phase offset specification do not apply.

CLK_STOP and OE do not affect the PLL feedback output (QFB) and down stream clocks can be disabled without the internal PLL losing lock.

The MPC9608 is fully 2.5V or 3.3V compatible and requires no external components for the internal PLL. All inputs accept LVCMOS signals while the outputs provide LVCMOS compatible levels with the capability to drive terminated $50\ \Omega$ transmission lines on the incident edge. For series terminated transmission lines, each of the MPC9608 outputs can drive one or two traces giving the devices an effective fanout of 1:20. The device is packaged in a $7 \times 7\ \text{mm}^2$ 32-lead LQFP package.

MPC9608

**LOW VOLTAGE 3.3V/2.5V
LVCMOS 1:10 ZERO-DELAY
CLOCK BUFFER**

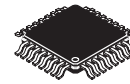

FA SUFFIX
32-LEAD LQFP PACKAGE
CASE 873A

1. Final AC specifications pending final device characterization.

This document contains information on a product under development. Motorola reserves the right to change or discontinue this product without notice.



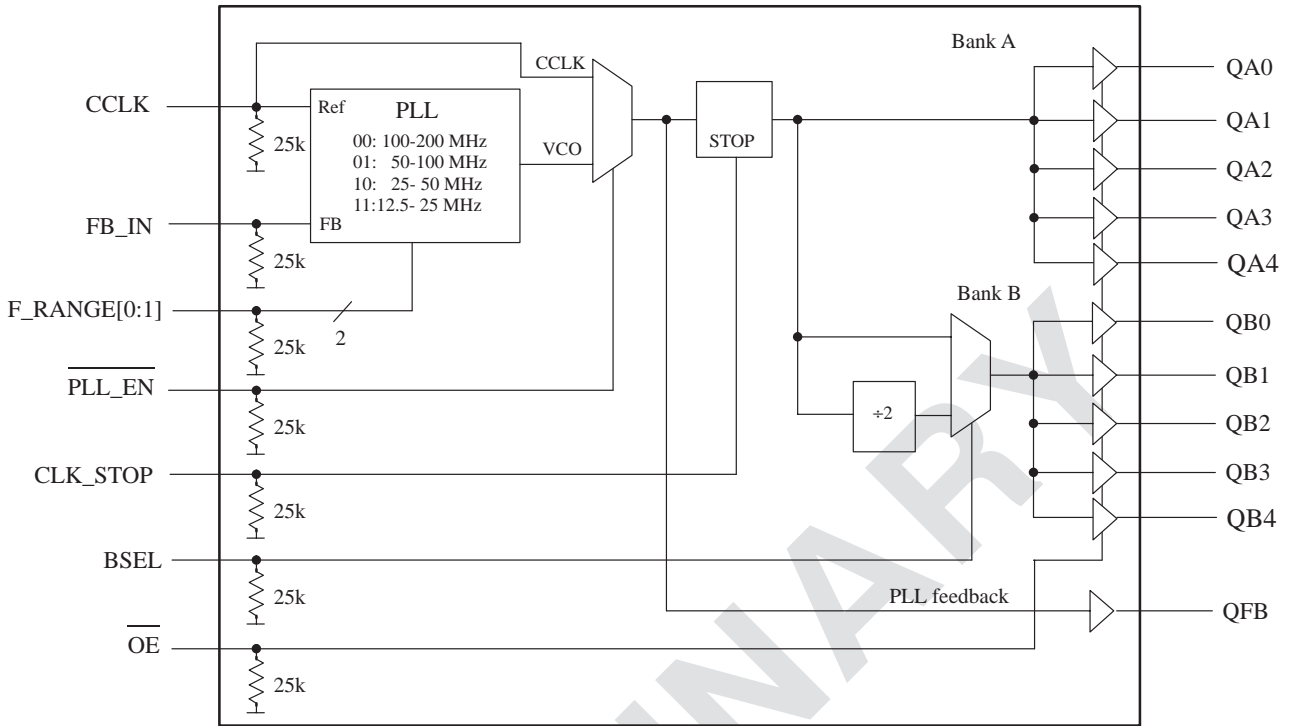

Figure 1. MPC9608 Logic Diagram

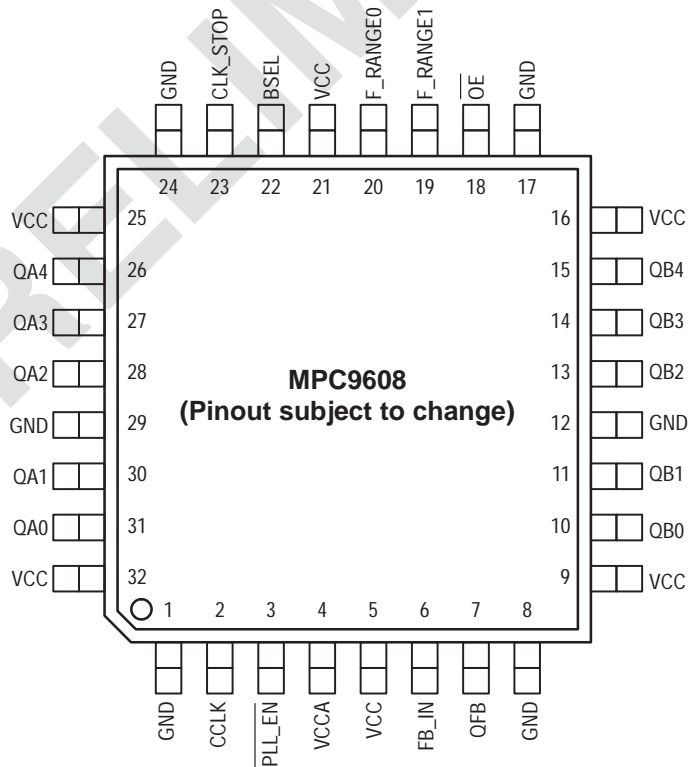

Figure 2. MPC9608 32-Lead Package Pinout (Top View)

TABLE 1: PIN CONFIGURATION

Pin	I/O	Type	Function
CCLK	Input	LVC MOS	PLL reference clock signal
FB_IN	Input	LVC MOS	PLL feedback signal input, connect to a QFB output
F_RANGE[0:1]	Input	LVC MOS	PLL frequency range select
BSEL	Input	LVC MOS	Frequency divider select for bank B outputs
PLL_EN	Input	LVC MOS	PLL enable/disable
OE	Input	LVC MOS	Output enable/disable (high-impedance tristate)
CLK_STOP	Input	LVC MOS	Synchronous clock enable/stop
QA0-4, QB0-4	Output	LVC MOS	Clock outputs
QFB	Output	LVC MOS	PLL feedback signal output. Connect to FB_IN
GND	Supply	Ground	Negative power supply
VCCA	Supply	VCC	PLL positive power supply (analog power supply). The MPC9608 requires an external RC filter for the analog power supply pin VCCA. Please see applications section for details.
VCC	Supply	VCC	Positive power supply for I/O and core

TABLE 2: FUNCTION TABLE

Control	Default	0	1
F_RANGE[0:1]	00	PLL frequency range. See Table 3 "Clock frequency configuration for QFB connected to FB_IN"	
BSEL	0	$f_{QB0-4} = f_{QA0-4}$	$f_{QB0-4} = f_{QA0-4} \div 2$
CLK_STOP	0	Outputs enabled	Outputs synchronously stopped in logic low state
OE	0	Outputs enabled (active)	Outputs disabled (high-impedance state), independent on CLK_STOP. Applying OE=1 and PLL_EN=1 resets the device. The PLL feedback output QFB is not affected by OE.
PLL_EN	0	Normal operation mode with PLL enabled.	Test mode with PLL disabled. CCLK is substituted for the internal VCO output. MPC9608 is fully static and no minimum frequency limit applies. All PLL related AC characteristics are not applicable. Applying OE=1 and PLL_EN=1 resets the device.

TABLE 3: Clock Frequency Configuration for QFB connected to FB_IN

F_RANGE[0]	F_RANGE[1]	BSEL	f _{REF} (CCLK) range [MHz]	QA0-QA4		QB0-B4		QFB
				Ratio	f _{QA0-4} [MHz]	Ratio	f _{QB0-4} [MHz]	
0	0	0	100.0—200.0	f _{REF}	100.0—200.0	f _{REF}	100.0—200.0	f _{REF}
		1				f _{REF} ÷ 2	50.0—25.0	f _{REF}
0	1	0	50.0—100.0	f _{REF}	50.0—100.0	f _{REF}	50.0—100.0	f _{REF}
		1				f _{REF} ÷ 2	25.0—50.0	f _{REF}
1	0	0	25.0—50.0	f _{REF}	25.0—50.0	f _{REF}	25.0—50.0	f _{REF}
		1				f _{REF} ÷ 2	12.5—25.0	f _{REF}
1	1	0	12.5—25.0	f _{REF}	12.5—25	f _{REF}	12.5—25.0	f _{REF}
		1				f _{REF} ÷ 2	50.0—100	f _{REF}

TABLE 4: GENERAL SPECIFICATIONS

Symbol	Characteristics	Min	Typ	Max	Unit	Condition
V _{TT}	Output termination voltage		V _{CC} ± 2		V	
MM	ESD protection (Machine model)	200			V	
HBM	ESD protection (Human body model)	2000			V	
LU	Latch-up immunity	200			mA	
C _{PD}	Power dissipation capacitance		10		pF	Per output
C _{IN}	Input capacitance		4.0		pF	Inputs

TABLE 5: ABSOLUTE MAXIMUM RATINGS^a

Symbol	Characteristics	Min	Max	Unit	Condition
V _{CC}	Supply Voltage	-0.3	3.6	V	
V _{IN}	DC Input Voltage	-0.3	V _{CC} +0.3	V	
V _{OUT}	DC Output Voltage	-0.3	V _{CC} +0.3	V	
I _{IN}	DC Input Current		±20	mA	
I _{OUT}	DC Output Current		±50	mA	
T _S	Storage temperature	-65	125	°C	

a. Absolute maximum continuous ratings are those maximum values beyond which damage to the device may occur. Exposure to these conditions or conditions beyond those indicated may adversely affect device reliability. Functional operation at absolute-maximum-rated conditions is not implied.

TABLE 6: DC CHARACTERISTICS ($V_{CC} = 3.3V \pm 5\%$, $T_A = -40^\circ$ to $85^\circ C$)

Symbol	Characteristics	Min	Typ	Max	Unit	Condition
V_{IH}	Input High Voltage	2.0		$V_{CC} + 0.3$	V	LVC MOS
V_{IL}	Input Low Voltage			0.8	V	LVC MOS
V_{OH}	Output High Voltage	2.4			V	$I_{OH} = -24 \text{ mA}^a$
V_{OL}	Output Low Voltage			0.55 0.30	V V	$I_{OL} = 24 \text{ mA}$ $I_{OL} = 12 \text{ mA}$
Z_{OUT}	Output Impedance		14 - 17		Ω	
I_{IN}	Input Current ^b			± 200	μA	$V_{IN} = V_{CC}$ or GND
I_{CCA}	Maximum PLL Supply Current		3.0	5.0	mA	V_{CCA} Pin
I_{CCQ}	Maximum Quiescent Supply Current			1.0	mA	All V_{CC} Pins

a. The MPC9608 is capable of driving 50Ω transmission lines on the incident edge. Each output drives one 50Ω parallel terminated transmission line to a termination voltage of V_{TT} . Alternatively, the device drives up to two 50Ω series terminated transmission lines.

b. Inputs have pull-down resistors affecting the input current.

TABLE 7: AC CHARACTERISTICS ($V_{CC} = 3.3V \pm 5\%$, $T_A = -40^\circ$ to $85^\circ C$)^{a b}

Symbol	Characteristics	Min	Typ	Max	Unit	Condition
f_{ref}	Input reference frequency in PLL mode ^c F_RANGE = 00 F_RANGE = 01 F_RANGE = 10 F_RANGE = 11 Input reference frequency in PLL bypass mode ^d	100 50 25 12.5 0		200 100 50 25 TBD	MHz MHz MHz MHz MHz	
f_{MAX}	Output Frequency ^e F_RANGE = 00 F_RANGE = 01 F_RANGE = 10 F_RANGE = 11	100 50 25 12.5		200 100 50 25	MHz MHz MHz MHz	BSEL = 0 BSEL = 0 BSEL = 0 BSEL = 0
f_{refDC}	Reference Input Duty Cycle	25		75	%	
t_r, t_f	CCLK Input Rise/Fall Time			1.0	ns	0.8 to 2.0V
$t(\varnothing)$	Propagation Delay (static phase offset) CCLK to FB_IN F_RANGE = 00 F_RANGE = 01 F_RANGE = 10 F_RANGE = 11		± 100		ps	PLL locked
$t_{sk(o)}$	Output-to-Output Skew ^f			150	ps	
DC	Output Duty Cycle	45	50	55	%	
t_r, t_f	Output Rise/Fall Time	0.1		1.0	ns	0.55 to 2.4V
$t_{PLZ, HZ}$	Output Disable Time			10	ns	
$t_{PZL, LZ}$	Output Enable Time			10	ns	
$t_{JIT(CC)}$	Cycle-to-cycle jitter RMS (1 σ) ^g		15		ps	BSEL = 0
$t_{JIT(PER)}$	Period Jitter RMS (1 σ)		10		ps	BSEL = 0
$t_{JIT(\varnothing)}$	I/O Phase Jitter RMS (1 σ)		TBD		ps	BSEL = 0
t_S	Setup time, CLK_STOP to CCLK	100			ps	
t_H	Hold time, CCLK to CLK_STOP	100			ps	
BW	PLL closed loop bandwidth ^h F_RANGE = 00 F_RANGE = 01 F_RANGE = 10 F_RANGE = 11			TBD TBD TBD TBD	kHz kHz kHz kHz	
t_{LOCK}	Maximum PLL Lock Time		10		ms	

a. All AC characteristics are design targets and subject to change upon device characterization.

b. AC characteristics apply for parallel output termination of 50Ω to V_{TT} .

c. PLL mode requires $PLL_EN = 0$ to enable the PLL and zero-delay operation.

d. In bypass mode, the MPC9608 divides the input reference clock.

e. Applies for bank A and for bank B if BSEL = 0. If BSEL = 1, the min. and max. output frequency of bank B must be divided by two.

f. See application section for part-to-part skew calculation.

g. See application section for a jitter calculation for other confidence factors than 1 σ .

h. -3 dB point of PLL transfer characteristics.

TABLE 8: DC CHARACTERISTICS ($V_{CC} = 2.5V \pm 5\%$, $T_A = -40^\circ$ to $85^\circ C$)

Symbol	Characteristics	Min	Typ	Max	Unit	Condition
V_{IH}	Input High Voltage	1.7		$V_{CC} + 0.3$	V	LVC MOS
V_{IL}	Input Low Voltage	-0.3		0.7	V	LVC MOS
V_{OH}	Output High Voltage	1.8			V	$I_{OH} = -15 \text{ mA}^a$
V_{OL}	Output Low Voltage			0.6	V	$I_{OL} = 15 \text{ mA}$
Z_{OUT}	Output Impedance		17 - 20		Ω	
I_{IN}	Input Current			± 200	μA	$V_{IN} = V_{CC}$ or GND
I_{CCA}	Maximum PLL Supply Current		2.0	5.0	mA	V_{CCA} Pin
I_{CCQ}	Maximum Quiescent Supply Current			1.0	mA	All V_{CC} Pins

a. The MPC9608 is capable of driving 50Ω transmission lines on the incident edge. Each output drives one 50Ω parallel terminated transmission line to a termination voltage of V_{TT} . Alternatively, the device drives up to two 50Ω series terminated transmission lines per output.

TABLE 9: AC CHARACTERISTICS ($V_{CC} = 2.5V \pm 5\%$, $T_A = -40^\circ$ to $85^\circ C$)^{a b}

Symbol	Characteristics	Min	Typ	Max	Unit	Condition
f_{ref}	Input reference frequency in PLL mode ^c	F_RANGE = 00	100		200	MHz
		F_RANGE = 01	50		100	MHz
		F_RANGE = 10	25		50	MHz
		F_RANGE = 11	12.5		25	MHz
		Input reference frequency in PLL bypass mode ^d	0		TBD	MHz
f_{MAX}	Output Frequency ^e	F_RANGE = 00	100		200	MHz
		F_RANGE = 01	50		100	MHz
		F_RANGE = 10	25		50	MHz
		F_RANGE = 11	12.5		25	MHz
f_{refDC}	Reference Input Duty Cycle	25		75	%	
t_r, t_f	CCLK Input Rise/Fall Time			1.0	ns	0.7 to 1.7V
$t(\varnothing)$	Propagation Delay (static phase offset) CCLK to FB_IN		± 100		ps	PLL locked
$t_{sk(o)}$	Output-to-Output Skew ^f	F_RANGE = 00			150	ps
		F_RANGE = 01				
		F_RANGE = 10				
		F_RANGE = 11				
DC	Output Duty Cycle	45	50	55	%	
t_r, t_f	Output Rise/Fall Time	0.1		1.0	ns	0.6 to 1.8V
$t_{PLZ, HZ}$	Output Disable Time			10	ns	
$t_{PZL, LZ}$	Output Enable Time			10	ns	
$t_{JIT(CC)}$	Cycle-to-cycle jitter	RMS (1 σ) ^g	15		ps	BSEL = 0
$t_{JIT(PER)}$	Period Jitter	RMS (1 σ)	10		ps	BSEL = 0
$t_{JIT(\varnothing)}$	I/O Phase Jitter	RMS (1 σ)	TBD		ps	BSEL = 0
t_S	Setup time, CLK_STOP to CCLK	100			ps	
t_H	Hold time, CCLK to CLK_STOP	100			ps	
BW	PLL closed loop bandwidth ^h	F_RANGE = 00			TBD	kHz
		F_RANGE = 01			TBD	kHz
		F_RANGE = 10			TBD	kHz
		F_RANGE = 11			TBD	kHz
t_{LOCK}	Maximum PLL Lock Time		10		ms	

a. All AC characteristics are design targets and subject to change upon device characterization.

b. AC characteristics apply for parallel output termination of 50Ω to V_{TT} .

c. PLL mode requires $PLL_EN = 0$ to enable the PLL and zero-delay operation.

d. In bypass mode, the MPC9608 divides the input reference clock.

e. Applies for bank A and for bank B if BSEL = 0. If BSEL = 1, the min. and max. output frequency of bank B must be divided by two.

f. See application section for part-to-part skew calculation.

g. See application section for a jitter calculation for other confidence factors than 1 σ .

h. -3 dB point of PLL transfer characteristics.

APPLICATIONS INFORMATION

Power Supply Filtering

The MPC9608 is a mixed analog/digital product. Its analog circuitry is naturally susceptible to random noise, especially if this noise is seen on the power supply pins. Random noise on the V_{CCA} (PLL) power supply impacts the device characteristics, for instance I/O jitter. The MPC9608 provides separate power supplies for the output buffers (V_{CC}) and the phase-locked loop (V_{CCA}) of the device. The purpose of this design technique is to isolate the high switching noise digital outputs from the relatively sensitive internal analog phase-locked loop. In a digital system environment where it is more difficult to minimize noise on the power supplies a second level of isolation may be required. The simple but effective form of isolation is a power supply filter on the V_{CCA} pin for the MPC9608. Figure 3. illustrates a typical power supply filter scheme. The MPC9608 frequency and phase stability is most susceptible to noise with spectral content in the 100kHz to 20MHz range. Therefore the filter should be designed to target this range. The key parameter that needs to be met in the final filter design is the DC voltage drop across the series filter resistor R_F . From the data sheet the I_{CCA} current (the current sourced through the V_{CCA} pin) is typically 3 mA (5 mA maximum), assuming that a minimum of 2.325V ($V_{CC}=3.3V$ or $V_{CC}=2.5V$) must be maintained on the V_{CCA} pin. The resistor R_F shown in Figure 3. "VCCA Power Supply Filter" must have a resistance of 270 Ω ($V_{CC}=3.3V$) or 9-10 Ω ($V_{CC}=2.5V$) to meet the voltage drop criteria.

$$\begin{array}{ll} R_F = 270\Omega \text{ for } V_{CC} = 3.3V & C_F = 1 \mu\text{F for } V_{CC} = 3.3V \\ R_F = 9\text{-}10\Omega \text{ for } V_{CC} = 2.5V & C_F = 22 \mu\text{F for } V_{CC} = 2.5V \end{array}$$

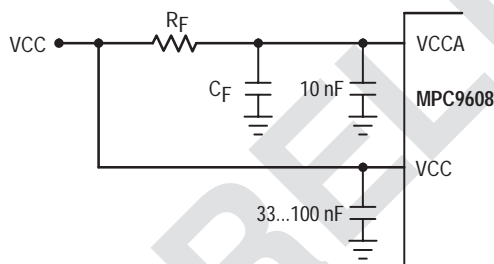

Figure 3. VCCA Power Supply Filter

The minimum values for R_F and the filter capacitor C_F are defined by the required filter characteristics: the RC filter should provide an attenuation greater than 40 dB for noise whose spectral content is above 100 kHz. In the example RC filter shown in Figure 3. "VCCA Power Supply Filter", the filter cut-off frequency is around 3-5 kHz and the noise attenuation at 100 kHz is better than 42 dB.

As the noise frequency crosses the series resonant point of an individual capacitor its overall impedance begins to look inductive and thus increases with increasing frequency. The parallel capacitor combination shown ensures that a low impedance path to ground exists for frequencies well above the bandwidth of the PLL. Although the MPC9608 has several design features to minimize the susceptibility to power supply noise (isolated power and grounds and fully differential PLL) there still may be applications in which

overall performance is being degraded due to system power supply noise. The power supply filter schemes discussed in this section should be adequate to eliminate power supply noise related problems in most designs.

Using the MPC9608 in zero-delay applications

Nested clock trees are typical applications for the MPC9608. Designs using the MPC9608 as LVCMOS PLL fanout buffer with zero insertion delay will show significantly lower clock skew than clock distributions developed from CMOS fanout buffers. The external feedback option of the MPC9608 clock driver allows for its use as a zero delay buffer. By using the QFB output as a feedback to the PLL the propagation delay through the device is virtually eliminated. The PLL aligns the feedback clock output edge with the clock input reference edge resulting a near zero delay through the device. The maximum insertion delay of the device in zero-delay applications is measured between the reference clock input and any output. This effective delay consists of the static phase offset, I/O jitter (phase or long-term jitter), feedback path delay and the output-to-output skew error relative to the feedback output.

Calculation of part-to-part skew

The MPC9608 zero delay buffer supports applications where critical clock signal timing can be maintained across several devices. If the reference clock inputs of two or more MPC9608 are connected together, the maximum overall timing uncertainty from the common CCLK input to any output is:

$$t_{SK(PP)} = t_{(\emptyset)} + t_{SK(O)} + t_{PD, LINE(FB)} + t_{JIT(\emptyset)} \cdot C_F$$

This maximum timing uncertainty consists of 4 components: static phase offset, output skew, feedback board trace delay and I/O (phase) jitter:

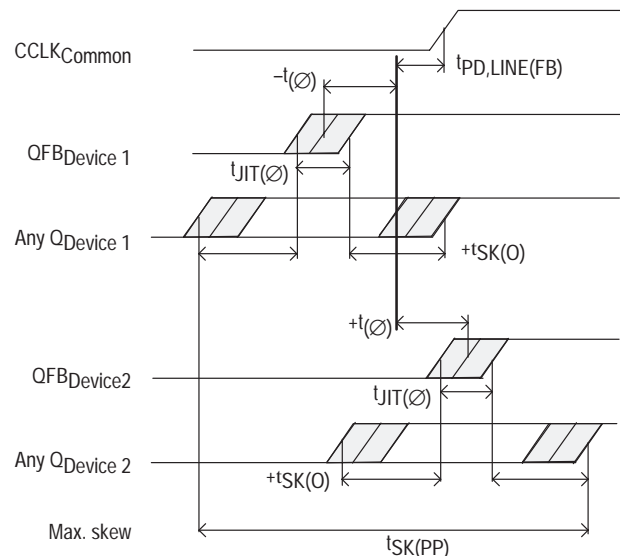

Figure 4. MPC9608 max. device-to-device skew

Due to the statistical nature of I/O jitter a RMS value (1 σ) is specified. I/O jitter numbers for other confidence factors (CF) can be derived from Table 10.

Table 10: Confidence Factor CF

CF	Probability of clock edge within the distribution
$\pm 1\sigma$	0.68268948
$\pm 2\sigma$	0.95449988
$\pm 3\sigma$	0.99730007
$\pm 4\sigma$	0.99993663
$\pm 5\sigma$	0.99999943
$\pm 6\sigma$	0.99999999

The feedback trace delay is determined by the board layout and can be used to fine-tune the effective delay through each device. In the following example calculation a I/O jitter confidence factor of 99.7% ($\pm 3\sigma$) is assumed, resulting in a worst case timing uncertainty from input to any output of -295 ps to 295 ps¹ relative to CCLK:

$$t_{SK(PP)} = [-100ps...100ps] + [-150ps...150ps] + [(15ps \cdot -3)...(15ps \cdot 3)] + t_{PD, LINE(FB)}$$

$$t_{SK(PP)} = [-295ps...295ps] + t_{PD, LINE(FB)}$$

Due to the frequency dependence of I/O jitter, Figure 5 "Max. I/O Jitter versus frequency" can be used for a more precise timing performance analysis.



Figure 5. Max. I/O Jitter versus frequency

Driving Transmission Lines

The MPC9608 clock driver was designed to drive high speed signals in a terminated transmission line environment. To provide the optimum flexibility to the user the output drivers were designed to exhibit the lowest impedance possible. With an output impedance of less than 20 Ω the drivers can drive either parallel or series terminated transmission lines. For more information on transmission lines the reader is referred to Motorola application note AN1091. In most high performance clock networks point-to-point distribution of signals is the method of choice. In a point-to-point scheme either series terminated or parallel terminated transmission lines can be used. The parallel

technique terminates the signal at the end of the line with a 50 Ω resistance to $V_{CC}+2$.

This technique draws a fairly high level of DC current and thus only a single terminated line can be driven by each output of the MPC9608 clock driver. For the series terminated case however there is no DC current draw, thus the outputs can drive multiple series terminated lines. Figure 6. "Single versus Dual Transmission Lines" illustrates an output driving a single series terminated line versus two series terminated lines in parallel. When taken to its extreme the fanout of the MPC9608 clock driver is effectively doubled due to its capability to drive multiple lines.

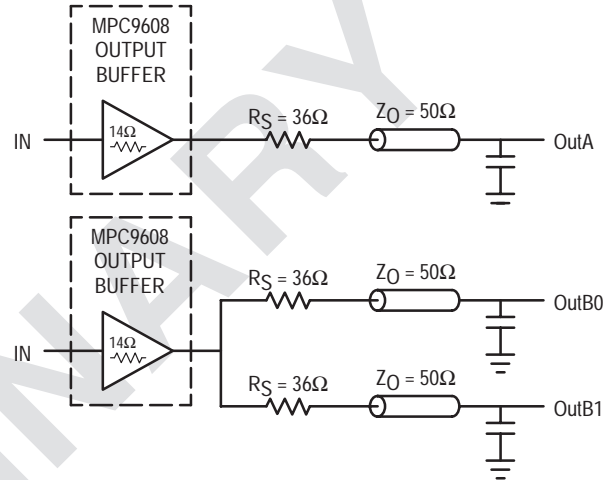

Figure 6. Single versus Dual Transmission Lines

The waveform plots in Figure 7. "Single versus Dual Line Termination Waveforms" show the simulation results of an output driving a single line versus two lines. In both cases the drive capability of the MPC9608 output buffer is more than sufficient to drive 50 Ω transmission lines on the incident edge. Note from the delay measurements in the simulations a delta of only 43ps exists between the two differently loaded outputs. This suggests that the dual line driving need not be used exclusively to maintain the tight output-to-output skew of the MPC9608. The output waveform in Figure 7. "Single versus Dual Line Termination Waveforms" shows a step in the waveform, this step is caused by the impedance mismatch seen looking into the driver. The parallel combination of the 36 Ω series resistor plus the output impedance does not match the parallel combination of the line impedances. The voltage wave launched down the two lines will equal:

$$V_L = V_S (Z_0 \div (R_S + R_0 + Z_0))$$

$$Z_0 = 50\Omega \parallel 50\Omega$$

$$R_S = 36\Omega \parallel 36\Omega$$

$$R_0 = 14\Omega$$

$$V_L = 3.0 (25 \div (18+17+25))$$

$$= 1.31V$$

At the load end the voltage will double, due to the near unity reflection coefficient, to 2.6V. It will then increment towards the quiescent 3.0V in steps separated by one round trip delay (in this case 4.0ns).

1. Skew data are design targets and pending device specifications.

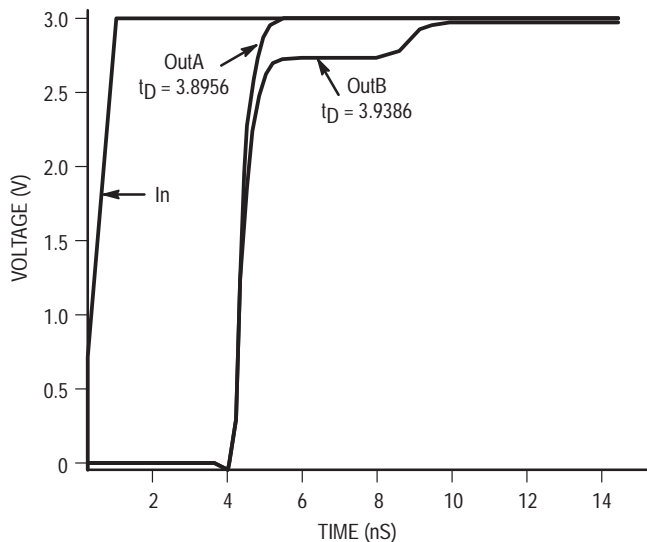

Figure 7. Single versus Dual Waveforms

Since this step is well above the threshold region it will not cause any false clock triggering, however designers may be uncomfortable with unwanted reflections on the line. To better

match the impedances when driving multiple lines the situation in Figure 8. “Optimized Dual Line Termination” should be used. In this case the series terminating resistors are reduced such that when the parallel combination is added to the output buffer impedance the line impedance is perfectly matched.

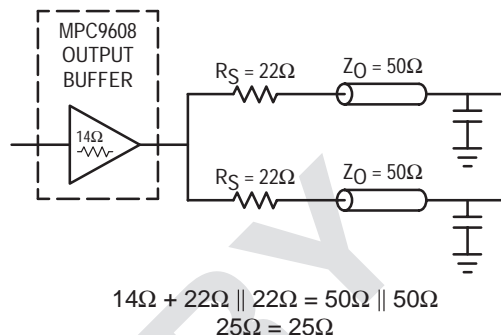

Figure 8. Optimized Dual Line Termination

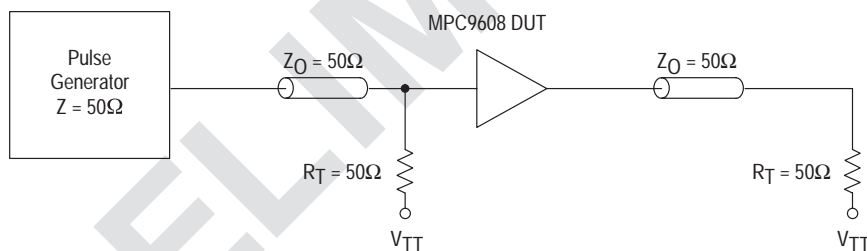
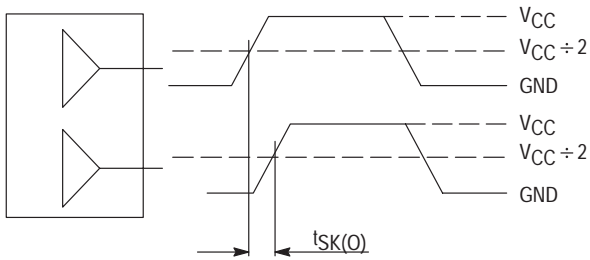

Figure 9. CCLK MPC9608 AC test reference for $V_{CC} = 3.3V$ and $V_{CC} = 2.5V$



The pin-to-pin skew is defined as the worst case difference in propagation delay between any similar delay path within a single device

Figure 10. Output-to-output Skew $t_{SK(O)}$

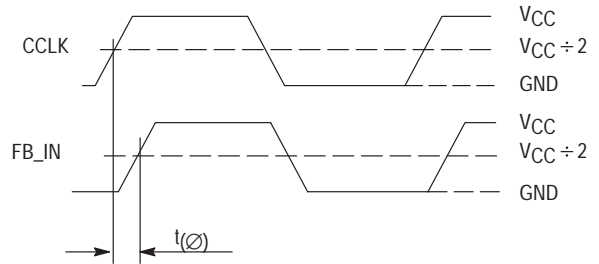
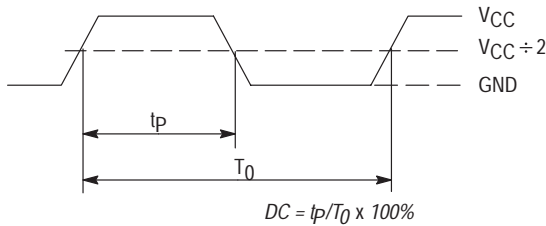
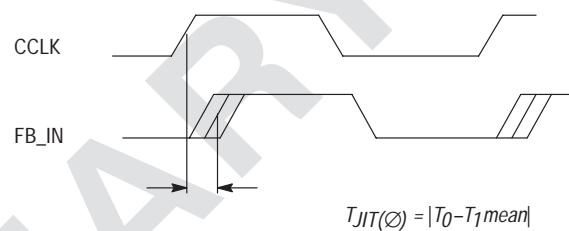

Figure 11. Propagation delay (t_{pD} , static phase offset) test reference



The time from the PLL controlled edge to the non controlled edge, divided by the time between PLL controlled edges, expressed as a percentage

Figure 12. Output Duty Cycle (DC)



The deviation in t_0 for a controlled edge with respect to a t_0 mean in a random sample of cycles

Figure 13. I/O Jitter

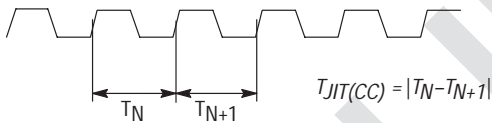

The variation in cycle time of a signal between adjacent cycles, over a random sample of adjacent cycle pairs

Figure 14. Cycle-to-cycle Jitter

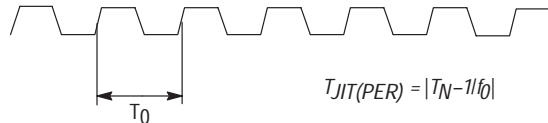

The deviation in cycle time of a signal with respect to the ideal period over a random sample of cycles

Figure 15. Period Jitter

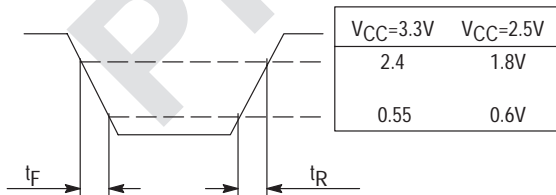

Figure 16. Output Transition Time Test Reference

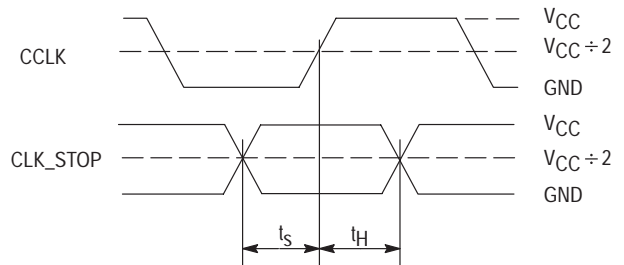
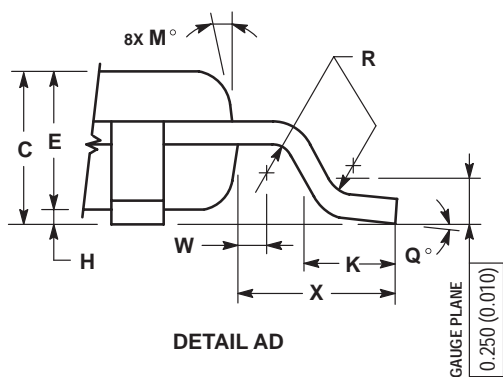
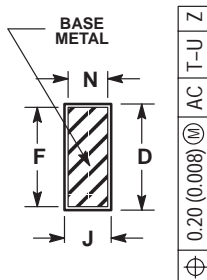
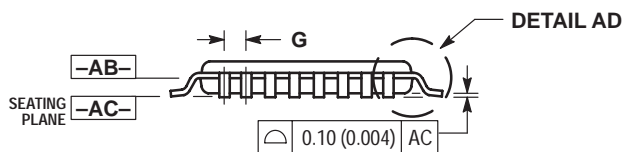
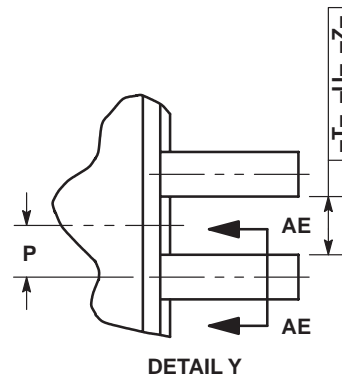
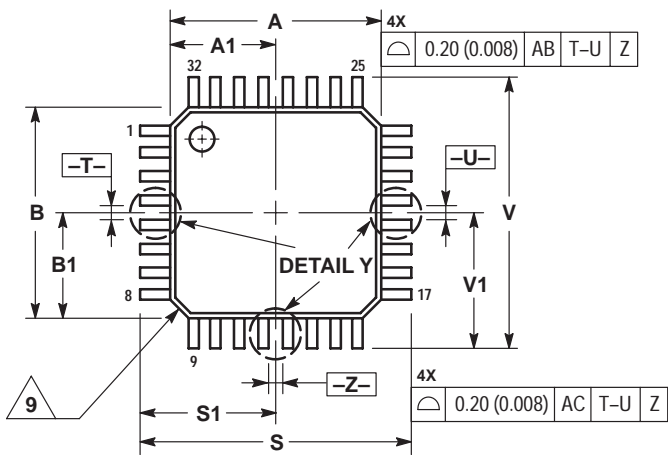

Figure 17. Setup and Hold Time (t_s , t_H) Test Reference

OUTLINE DIMENSIONS

FA SUFFIX
LQFP PACKAGE
CASE 873A-02
ISSUE A



- NOTES:
1. DIMENSIONING AND TOLERANCING PER ANSI Y14.5M, 1982.
 2. CONTROLLING DIMENSION: MILLIMETER.
 3. DATUM PLANE -AB- IS LOCATED AT BOTTOM OF LEAD AND IS COINCIDENT WITH THE LEAD WHERE THE LEAD EXITS THE PLASTIC BODY AT THE BOTTOM OF THE PARTING LINE.
 4. DATUMS -T-, -U-, AND -Z- TO BE DETERMINED AT DATUM PLANE -AB-.
 5. DIMENSIONS S AND V TO BE DETERMINED AT SEATING PLANE -AC-.
 6. DIMENSIONS A AND B DO NOT INCLUDE MOLD PROTRUSION. ALLOWABLE PROTRUSION IS 0.250 (0.010) PER SIDE. DIMENSIONS A AND B DO INCLUDE MOLD MISMATCH AND ARE DETERMINED AT DATUM PLANE -AB-.
 7. DIMENSION D DOES NOT INCLUDE DAMBAR PROTRUSION. DAMBAR PROTRUSION SHALL NOT CAUSE THE D DIMENSION TO EXCEED 0.520 (0.020).
 8. MINIMUM SOLDER PLATE THICKNESS SHALL BE 0.0076 (0.0003).
 9. EXACT SHAPE OF EACH CORNER MAY VARY FROM DEPICTION.

DIM	MILLIMETERS		INCHES	
	MIN	MAX	MIN	MAX
A	7.000 BSC	0.276 BSC		
A1	3.500 BSC	0.138 BSC		
B	7.000 BSC	0.276 BSC		
B1	3.500 BSC	0.138 BSC		
C	1.400	1.600	0.055	0.063
D	0.300	0.450	0.012	0.018
E	1.350	1.450	0.053	0.057
F	0.300	0.400	0.012	0.016
G	0.800 BSC	0.031 BSC		
H	0.050	0.150	0.002	0.006
J	0.090	0.200	0.004	0.008
K	0.500	0.700	0.020	0.028
M	12° REF	12° REF		
N	0.090	0.160	0.004	0.006
P	0.400 BSC	0.016 BSC		
Q	1°	5°	1°	5°
R	0.150	0.250	0.006	0.010
S	9.000 BSC	0.354 BSC		
S1	4.500 BSC	0.177 BSC		
V	9.000 BSC	0.354 BSC		
V1	4.500 BSC	0.177 BSC		
W	0.200 REF	0.008 REF		
X	1.000 REF	0.039 REF		

Motorola reserves the right to make changes without further notice to any products herein. Motorola makes no warranty, representation or guarantee regarding the suitability of its products for any particular purpose, nor does Motorola assume any liability arising out of the application or use of any product or circuit, and specifically disclaims any and all liability, including without limitation consequential or incidental damages. "Typical" parameters which may be provided in Motorola data sheets and/or specifications can and do vary in different applications and actual performance may vary over time. All operating parameters, including "Typicals" must be validated for each customer application by customer's technical experts. Motorola does not convey any license under its patent rights nor the rights of others. Motorola products are not designed, intended, or authorized for use as components in systems intended for surgical implant into the body, or other applications intended to support or sustain life, or for any other application in which the failure of the Motorola product could create a situation where personal injury or death may occur. Should Buyer purchase or use Motorola products for any such unintended or unauthorized application, Buyer shall indemnify and hold Motorola and its officers, employees, subsidiaries, affiliates, and distributors harmless against all claims, costs, damages, and expenses, and reasonable attorney fees arising out of, directly or indirectly, any claim of personal injury or death associated with such unintended or unauthorized use, even if such claim alleges that Motorola was negligent regarding the design or manufacture of the part. Motorola and  are registered trademarks of Motorola, Inc. Motorola, Inc. is an Equal Opportunity/Affirmative Action Employer.

How to reach us:

USA/EUROPE/Locations Not Listed: Motorola Literature Distribution;
P.O. Box 5405, Denver, Colorado 80217. 1-303-675-2140 or 1-800-441-2447

JAPAN: Motorola Japan Ltd.; SPS, Technical Information Center, 3-20-1,
Minami-Azabu, Minato-ku, Tokyo 106-8573 Japan. 81-3-3440-3569

Technical Information Center: 1-800-521-6274

ASIA/PACIFIC: Motorola Semiconductors H.K. Ltd.; Silicon Harbour Centre,
2, Dai King Street, Tai Po Industrial Estate, Tai Po, N.T., Hong Kong.
852-26668334

HOME PAGE: <http://www.motorola.com/semiconductors/>