

Features

- Data Rate up to 50 MHz (2 Outputs at 25 MHz Each)
- Pixel Size: 10 μm x 10 μm (10 μm Pitch)
- 300 to 1100 nm Spectral Range
- High Sensitivity and Lag Free Photodiodes
- Very Low Noise (30 pJ/cm² Noise Equivalent Illumination)
- Antiblooming
- Exposure Control
- 20-lead 0.4" DIL Package

Description

TH7815 linear arrays are based on Atmel's most recent technology in terms of design and performance. The flexibility and performance of these devices provide the opportunity to use them in most vision systems for industrial applications (web inspection, process control, sorting and inspection of various parts), document scanning up to 200 dpi and metrology.

Pin Identification

All pins must be connected.

Pin Number	Symbol	Function
4, 17	VDD1,2	Output Amplifiers Drain Supply
3, 18	VOS1,2	Video Outputs
5	VS	Output Amplifiers Substate Bias
20	VDR	Reset Drain Supply
2	VGS	Output Gate Bias
14	ΦL1	Readout Register Clocks
13	ΦL2	
15	ΦR	Reset Clock
10	ΦA	Antiblooming Gate Bias/Clock
7	VA	Antiblooming Drain Bias
8	VST	Storage Gate Bias
11	ΦP	Transfer Gate Clock
1, 6, 9, 12, 16, 19	VSS	Ground, Optical Grounding (Internally Connected)

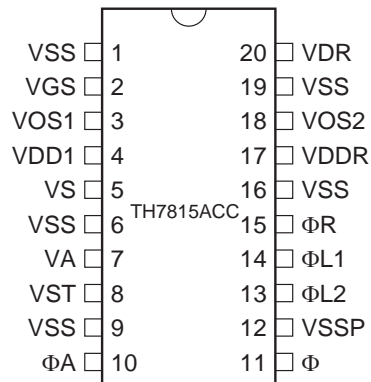

**50 MHz 4096
Linear CCDs**

TH7815ACC



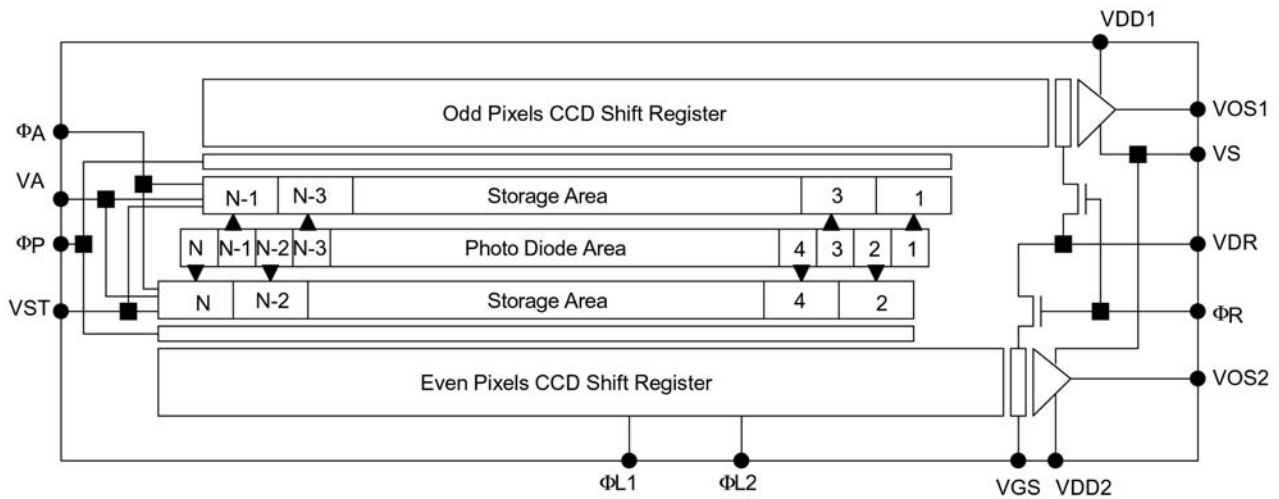

Absolute Maximum Ratings*

Storage Temperature Range	-55°C to +150°C
Operating Temperature Range.....	-40°C to +85°C
Thermal Cycling.....	15°C/min
Maximum Applied Voltages:	
• Pins 2, 8, 10, 11, 13, 14, 15	-0.3 to 15V
• Pins 4, 5, 7, 17, 20	-0.3 to 16V
• Pins 1, 6, 9, 12, 16, 19	0V (ground)

Note: Stresses above those listed under absolute maximum ratings may cause permanent device failure. Functionally at or above these limits is not implied. Exposure to absolute maximum ratings for extended periods may affect device reliability.

- Operating range defines the limits within which the functionality is guaranteed.
- Electrical limits of applied signals are given in operating conditions section.

Operating Precautions

Shorting the video outputs to any other pin, even temporarily, can permanently damage the on-chip output amplifier.

Operating Conditions

Table 1. DC Characteristics

Parameter	Symbol	Value			Unit
		Min.	Typ.	Max.	
Output Amplifier Drain Supply	VDD1, VDD2	14.5	15	15.5	V
Storage Gate Bias	VST	2.2	2.4	2.6	V
Antiblooming Gate (See Pixel Saturation Adjustment)	ΦA	2	4	7	V
Reset Bias	VDR	13.5	14	14.5	V
Antiblooming Diode Bias	VA	14.5	15	15.5	V
Register Output Gate Bias	VGS	2.2	2.4	2.6	V
Output Amplifier Source Supply	VS		0		V
Ground	VSS		0		V

Table 2. Drive Clocks Characteristics

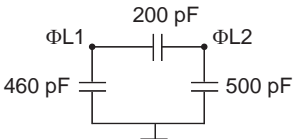
Parameter	Symbol	Value			Unit	Remarks
		Min.	Typ.	Max.		
Reset Gate High Level Low Level	ΦR	8.5	9	9.5	V	Clock Capacitance < 50 pF
		-0.1	0	0.4	V	
Transfer Gate High Level Low Level	ΦP	8.5	9	9.5	V	Clock Capacitance < 200 pF
		-0.1	0	0.4	V	
Readout Register Clocks High Level Low Level	$\Phi L1, 2$	8.5	9	9.5	V	
		-0.1	0	0.4	V	
Maximum Readout Register Frequency	F_H		10	25	MHz	

Timing Diagrams

The following diagram shows the general clocking scheme for TH7815ACC.
The line is composed as follows:

Synopsis	Number of Prescan Pixels Per Output	Number of Useful Pixels Per Output	Total Number of Pixels Per Output
TH7815ACC	4	2048	2052

Postscan elements may be added in order to either increase the exposure time, or to provide a voltage reference level.

Figure 1. Line Timing Diagram

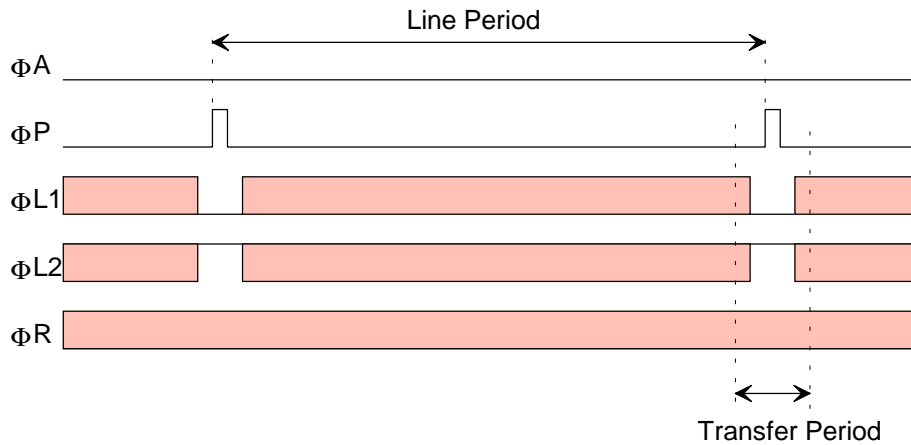

The following diagram shows the timing for the transfer period:

Figure 2. Line Transfer Period

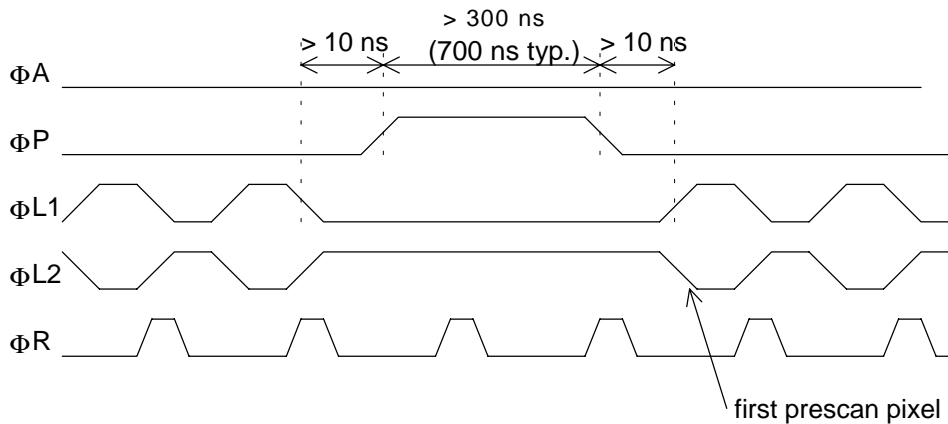

ΦR clock may also be held in high state during line transfer period.

The following diagram shows the detailed timing for the pixel readout:

Figure 3. Pixel Readout Timing Diagram

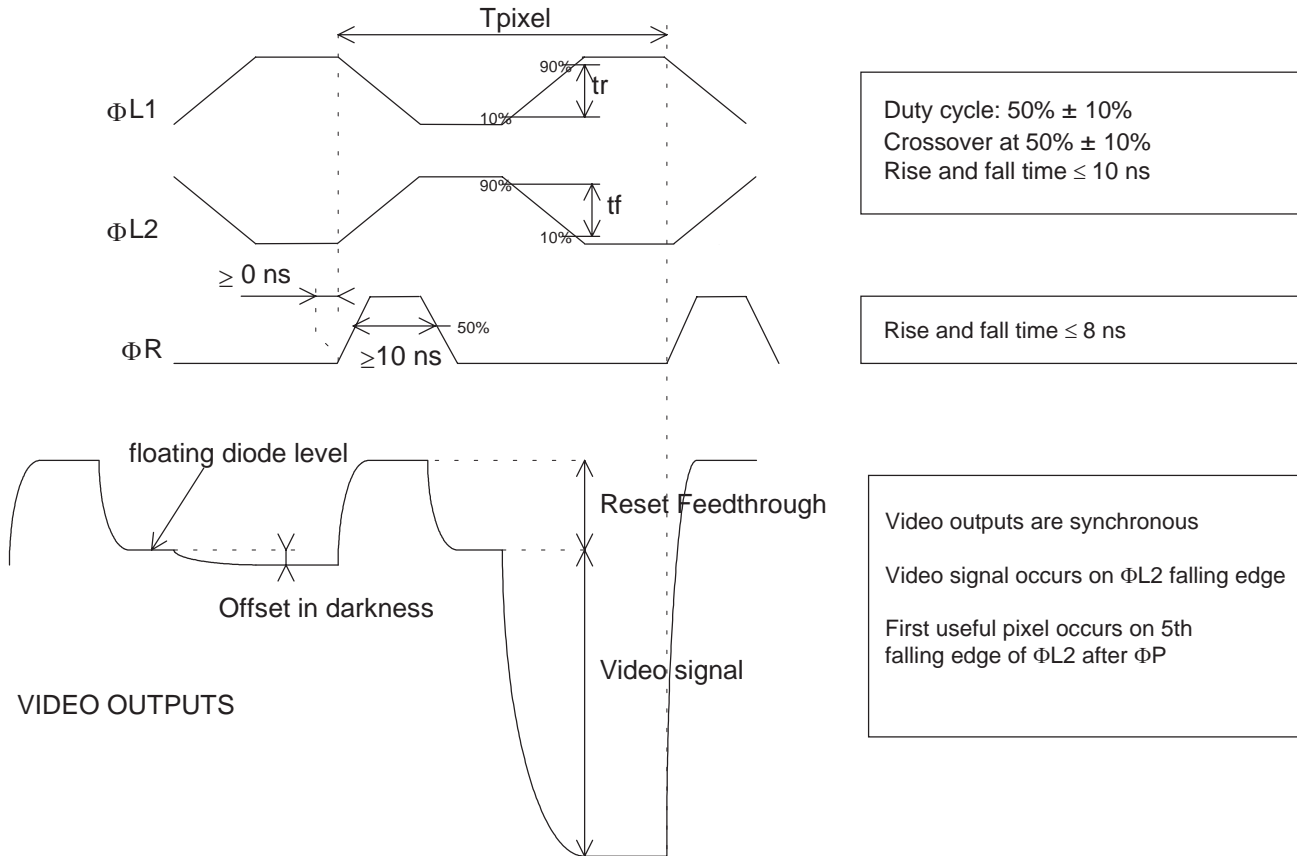

Exposure Time Reduction

The TH7815ACC antiblooming structure provides an electronic shutter capability by clocking phase ΦA during the line period. The timing diagram is described below:

Antiblooming Gate	ΦA	Min.	Typ.	Max.	Unit	Clock Capacitance < 200 pF
High Level		8.5	9	9.5	V	Low Level Sets Saturation Level
Low Level		2	4	7	V	See Pixel Saturation Adjustment
Pulse Min.		200 ns				

Figure 4. Exposure Time Reduction

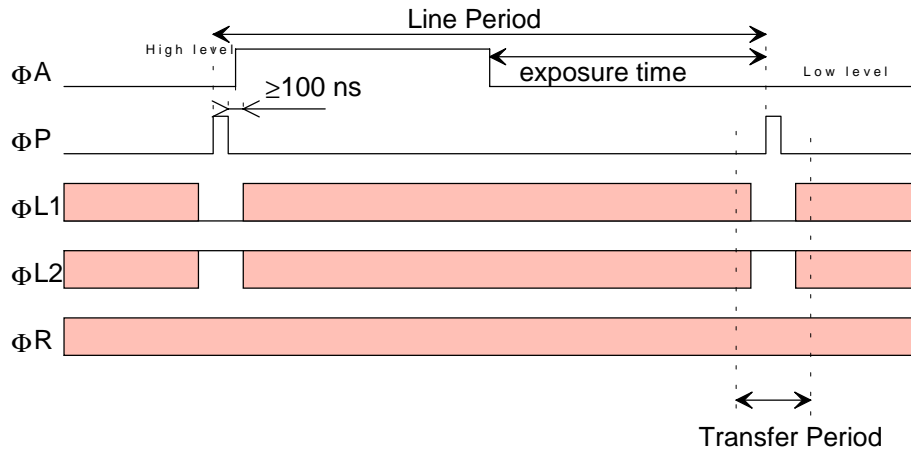

Electro-optical Performance

General test conditions

$T_{CASE} = 25^{\circ}C$

Light source: 2854K with 2 mm BG38 filter (unless specified) + F/11 optical aperture.

Typical operating conditions: 2 x 10 MHz.

All values are referred to prescan pixels level.

Parameter	Symbol	Value			Unit	Remarks
		Min.	Typ.	Max.		
Saturation Output Voltage	V_{SAT}	1.3	1.6	3	V	
Responsivity	R	7.5	8.5		$V/\mu J/cm^2$	
Responsivity Unbalance			2	5	%	
Photo Response Non-uniformity Peak-to-peak	PRNU		± 5	± 10	% V_{OS}	$\bar{V}_{OS} = 50$ mV to 1.2V
Dark Signal	DS		0.1	0.4	mV/ms	
Dark Signal Non-uniformity (1σ)	DSNU			0.1	mV/ms	
Temporal RMS Noise in Darkness	V_N		300		μV	
Dynamic Range	DR	4,300	5,300			
CTF	CTF		65		%	
LAG	LAG			1	%	
Charge Transfer Inefficiency (Per Stage)	HCTI			$8 \cdot 10^{-5}$		

Static and Dynamic Electrical Characteristics

Parameter	Symbol	Value			Unit	Remarks
		Min.	Typ.	Max		
Output Amplifier Supply Current	I_{DD}		10		mA	per amplifier
Output Impedance	Z_S	200	225	250	Ω	
DC Output Level	V_{REF}		10		V	
Output Conversion Factor	CVF		5		$\mu V/e^-$	
Offset In Darkness	DC off		30		mV	
Reset Feedthrough	Vft		400		mV	

Electro-optical Performances Without Infrared Cut-off Filter

The TH7815ACC special semiconductor process enables to exploit the silicon's high near infrared sensitivity while maintaining good imaging performances in terms of response uniformity and resolution. Typical changes in performance with and without OR filtering are summarized below:

Parameter	With IR Cut-off Filter	Without IR Cut-off Filter
Average Video Signal Due to a Given Scene Illumination	V_{OS}	$6 \times V_{OS}$
PRNU (Single Defects Excluded)	$\pm 5\%$	$\pm 5\%$
CTF at Nyquist Frequency	65%	40%

Pixel Saturation Adjustment

TH7815ACC antiblooming structure can be used to adjust the maximum saturation voltage, by adjusting the ΦA bias voltage. The following curve shows the relationship between V_{SAT} and $V\Phi A$.

Figure 5. Pixel Saturation Antiblooming Bias (Typical conditions)

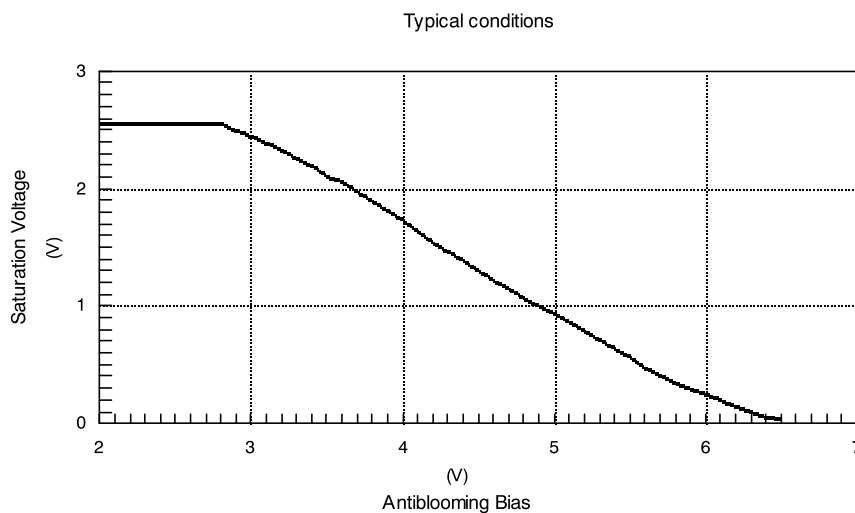

Spectral Responsivity

The following curve shows the typical spectral responsivity for TH7815ACC:

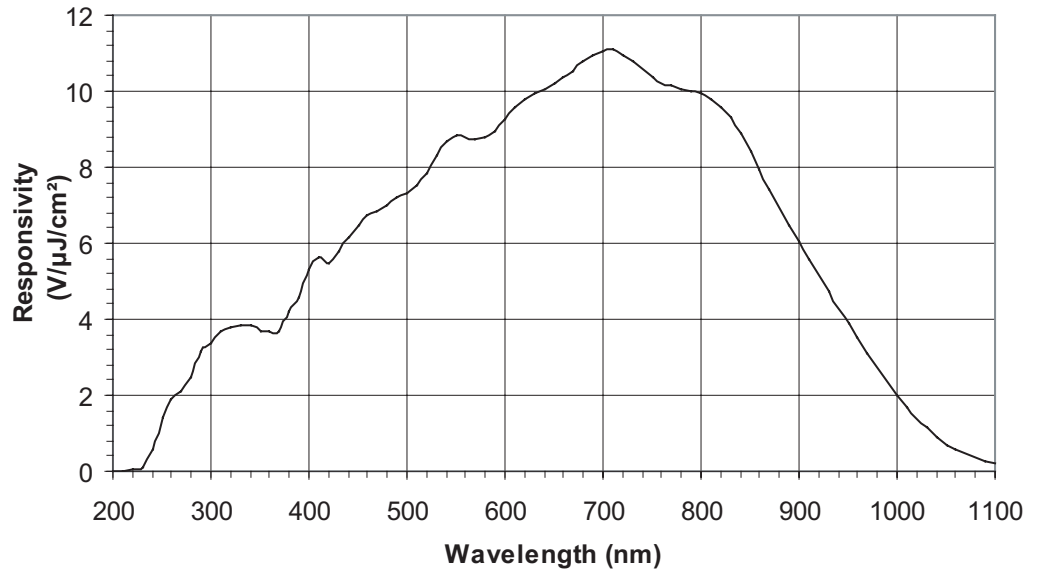

Packaging Drawing

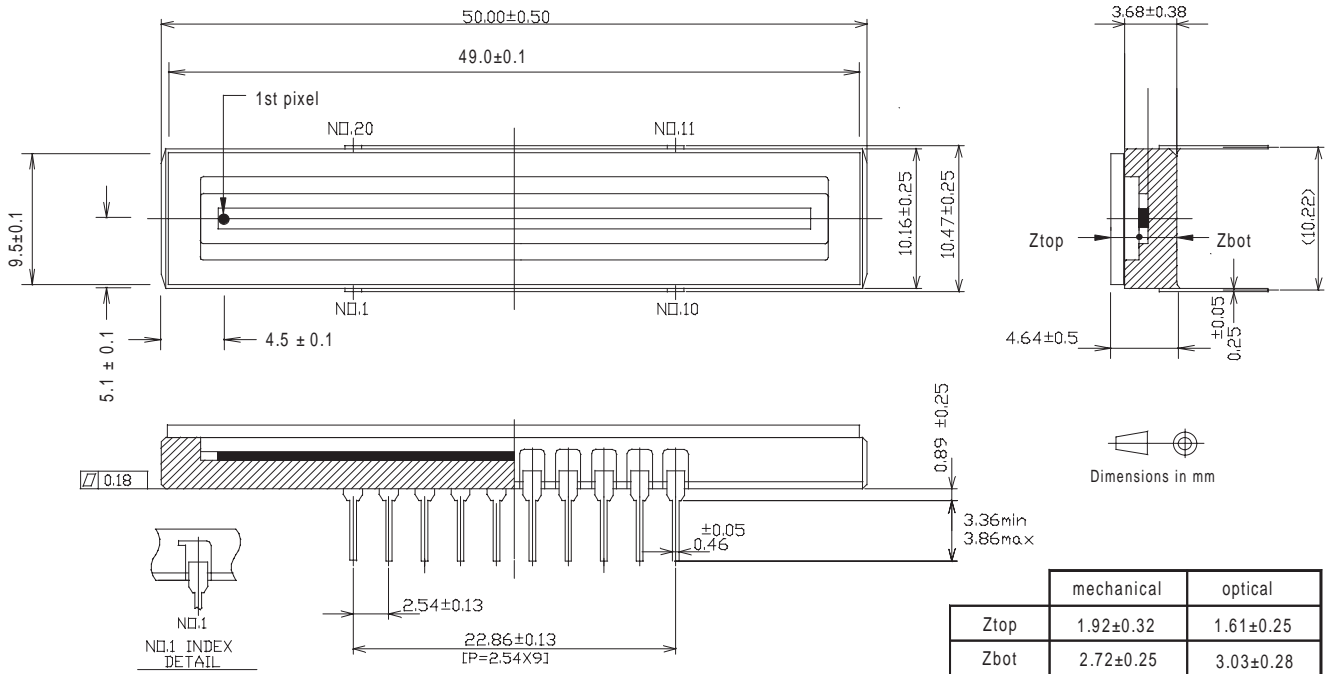

Ordering Code

TH7815ACC



Atmel Headquarters

Corporate Headquarters
2325 Orchard Parkway
San Jose, CA 95131
TEL 1(408) 441-0311
FAX 1(408) 487-2600

Europe

Atmel Sarl
Route des Arsenaux 41
Case Postale 80
CH-1705 Fribourg
Switzerland
TEL (41) 26-426-5555
FAX (41) 26-426-5500

Asia

Room 1219
Chinachem Golden Plaza
77 Mody Road Tsimhatsui
East Kowloon
Hong Kong
TEL (852) 2721-9778
FAX (852) 2722-1369

Japan

9F, Tonetsu Shinkawa Bldg.
1-24-8 Shinkawa
Chuo-ku, Tokyo 104-0033
Japan
TEL (81) 3-3523-3551
FAX (81) 3-3523-7581

Atmel Operations

Memory

2325 Orchard Parkway
San Jose, CA 95131
TEL 1(408) 441-0311
FAX 1(408) 436-4314

Microcontrollers

2325 Orchard Parkway
San Jose, CA 95131
TEL 1(408) 441-0311
FAX 1(408) 436-4314

La Chantrerie
BP 70602
44306 Nantes Cedex 3, France
TEL (33) 2-40-18-18-18
FAX (33) 2-40-18-19-60

ASIC/ASSP/Smart Cards

Zone Industrielle
13106 Rousset Cedex, France
TEL (33) 4-42-53-60-00
FAX (33) 4-42-53-60-01

1150 East Cheyenne Mtn. Blvd.
Colorado Springs, CO 80906
TEL 1(719) 576-3300
FAX 1(719) 540-1759

Scottish Enterprise Technology Park
Maxwell Building
East Kilbride G75 0QR, Scotland
TEL (44) 1355-803-000
FAX (44) 1355-242-743

RF/Automotive

Theresienstrasse 2
Postfach 3535
74025 Heilbronn, Germany
TEL (49) 71-31-67-0
FAX (49) 71-31-67-2340

1150 East Cheyenne Mtn. Blvd.
Colorado Springs, CO 80906
TEL 1(719) 576-3300
FAX 1(719) 540-1759

Biometrics/Imaging/Hi-Rel MPU/ High Speed Converters/RF Datacom

Avenue de Rochepleine
BP 123
38521 Saint-Egreve Cedex, France
TEL (33) 4-76-58-30-00
FAX (33) 4-76-58-34-80

e-mail
literature@atmel.com

Web Site
<http://www.atmel.com>

© Atmel Corporation 2002.

Atmel Corporation makes no warranty for the use of its products, other than those expressly contained in the Company's standard warranty which is detailed in Atmel's Terms and Conditions located on the Company's web site. The Company assumes no responsibility for any errors which may appear in this document, reserves the right to change devices or specifications detailed herein at any time without notice, and does not make any commitment to update the information contained herein. No licenses to patents or other intellectual property of Atmel are granted by the Company in connection with the sale of Atmel products, expressly or by implication. Atmel's products are not authorized for use as critical components in life support devices or systems.

ATMEL® is the registered trademarks of Atmel.

Other terms and product names may be the trademarks of others.

