



FEATURES

- Operating voltage 2.6 To 5.5V
- Built-in 256K bits SRAM
- Modified ADM algorithm
- Recording length : 12 sec
- Built-in automatic gain control for microphone input
- Auto PLAYBACK functional enable
- Direct driver speaker
- Built-in oscillator
- On chip low pass filter
- Input trigger pins : RECb, PLAYb, ERASEb
- SINGLE, MULTI segment mode
- MULTI segment play all
- Sequential segment erase in MULTI Segment mode

GENERAL DESCRIPTION

It is a mixed signal segment speech recorder. The chip integrates microphone amplifier, D/A converter, and static SRAM. Recordings are stored in static SRAM, providing low power consumption. It greatly reduces the number of external components needed for application such as toys, greeting card and voice memo... etc.

BLOCK DIAGRAM

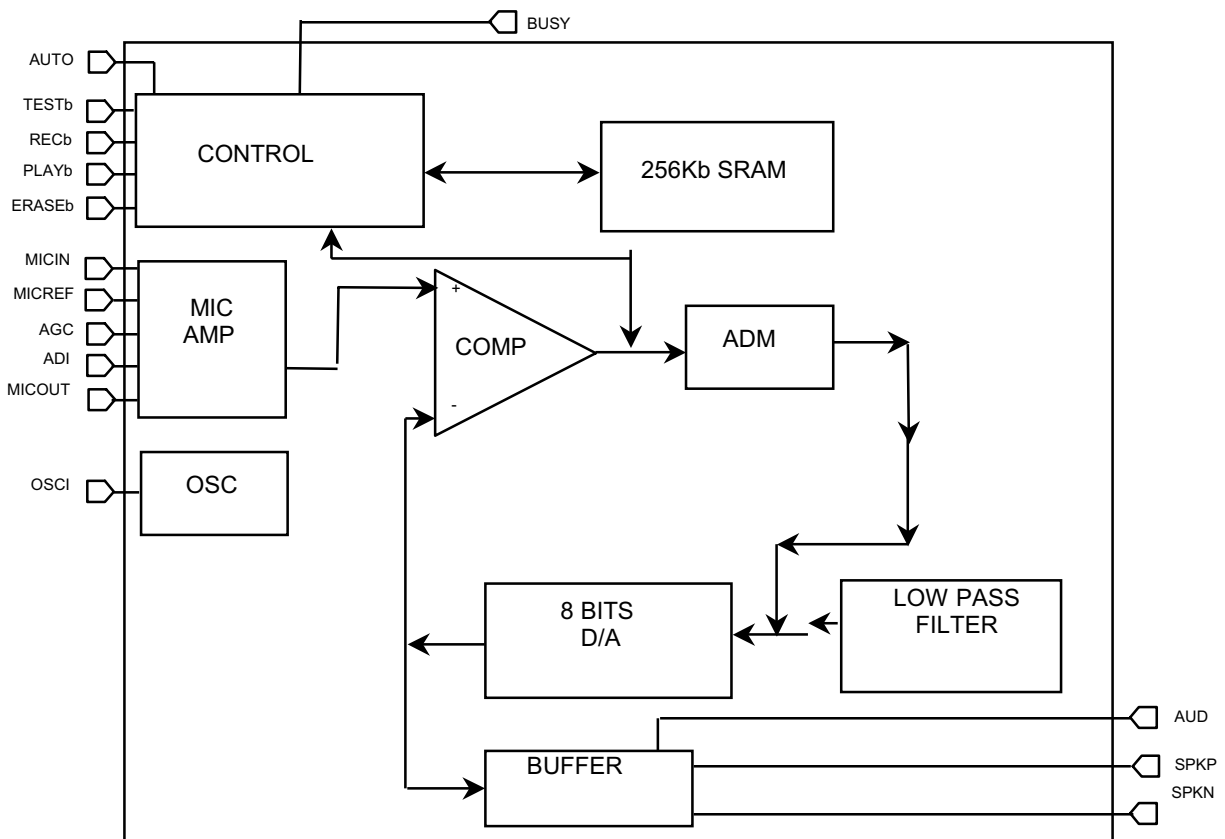



PIN CONFIGURATION (CHIP FORM)

- 1. VDDA : P : Analog positive power
- 2. SPKP : O : Positive terminal for direct drive speaker
- 3. SPKN : O : Negative terminal for direct drive speaker
- 4. VSSA : P : Analog negative power
- 5. MICOUT : O : Output terminal of built-in microphone pre-amplifier
- 6. MICIN : I : Input terminal of built-in microphone pre-amplifier
- 7. MICREF : I : Microphone reference bias.
- 8. AGC : I : Automatic gain control
- 9. ADI : O : Input terminal of fixed gain amplifier
- 10. RECb : I : Record cycle with level trigger.
- 11. PLAYb : I : Play enable with one short trigger and it will continuously play back, if the input always keeps in Low.
- 12. ERASEb : I : Segment erase in MULTI segment mode; connect to VDD in single segment mode
- 13. AUTO : I : Bonding option, auto playback the recorded segment
- 14. TESTb : I : Test pin; single and MULTI segment selection
- 15. BUSY : O : Active high indicate record or playback cycle
- 16. VDD : P : Digital positive power
- 17. OSCI : I : Oscillator
- 18. VSS : P : Digital negative power
- 19. AUD : O : Current output
- 20. NC : : Non-connected
- 21. NC : : Non-connected
- 22. NC : : Non-connected
- 23. NC : : Non-connected

MODE SELECTION

		ERASEb	TESTb	AUTO
Multi segment	Auto enable	**	NC	NC
	Auto disable	**	NC	VSS
Single segment	Auto enable	VDD	VSS	NC
	Auto disable	VDD	VSS	VSS

(「**」 : ERASE function, 「NC」 : Non-connected)

- 1. RECb, PLAYb, ERASEb internal pull-up.
- 2. AUTO, TESTb internal pull-up.
- 3. Mode selection is auto detected at the first time of power up.



PIN DESCRIPTION (28PIN SOP)

- 1. SPKP : O : Speaker positive
- 2. SPKN : O : Speaker negative
- 3. VSSA : P : Analog negative power
- 4. MICOUT : O : Microphone pre-amlifier output
- 5. MICIN : I : Microphone amplifier input
- 6. MICREF : I : Microphone reference bias
- 7. AGC : I : Automatic gain control
- 8. ADI : O : Input terminal of fixed gain amplifier
- 9. RECb : I : Record cycle with level trigger.
- 10. PLAYb : I : Play enable with one short trigger and it will continuously play back, if the input always keeps in Low.
- 11. ERASEb : I : Segment erase in MULTI segment mode; pull up to VDD in single segment mode.
- 12. AUTO : I : Auto playback after record enable
- 13. TESTb : I : Test pin
- 14. BUSY : O : Busy pin
- 15. VDD : P : Digital positive power
- 16. AUD : O : Voice output In current mode
- 17. NC : : Non-connected
- 18. NC : : Non-connected
- 19. NC : : Non-connected
- 20. NC : : Non-connected
- 21. VSS : P : Digital negative power
- 22. OSCI : I : Oscillator bias
- 23. NC : : Non-connected
- 24. NC : : Non-connected
- 25. NC : : Non-connected
- 26. NC : : Non-connected
- 27. NC : : Non-connected
- 28. VDDA : P : Analog positive power

ABSOLUTE MAXIMUM RATING

Characteristics	Symbol	Rating
DC supply voltage	V+	7.0V
Input voltage range	Vin	-0.5V to V+ + 0.5V
Operating temperature	Ta	-10°C to 70°C
Storage temperature	Tsto	-50°C to +150°C



ELECTRONICAL CHARACTERISTICS

Characteristics	Symbol	Limit			Unit	Test Condition
		MIN.	TYP.	MAX.		
Operating voltage	VDD	2.6	--	5.5	V	
Operating current	I _{op}	--	5	10	mA	
Standby current	I _{stby}	--	--	5	μA	VDD=3V
Audio output current	I _{AUD}	--	-1.5	--	mA	VDD=3V
Input high level	V _{IH}	2.8	--	--	V	VDD=3V
Input low level	V _{IL}	--	--	0.2	V	VDD=3V
Output high I (BUSY PIN)	I _{OH}	-10	--	--	mA	VDD=3V
Output sink I (BUSY PIN)	I _{OL}	4.0	--	--	mA	VDD=3V
Input resister (RECb, PLAYb, ERASEb)	R _{IN}	--	50	--	KOHM	Pull High



FUNCTION DESCRIPTION

1. Single Segment Normal mode (ERASEb = VDD, TESTb = GND, AUTO = GND)

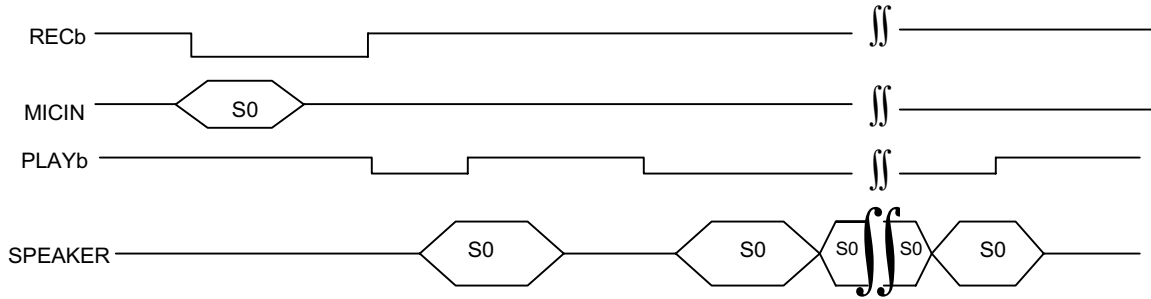

2. Single Segment AUTO mode (ERASEb = VDD, TESTb = GND, AUTO = VDD)

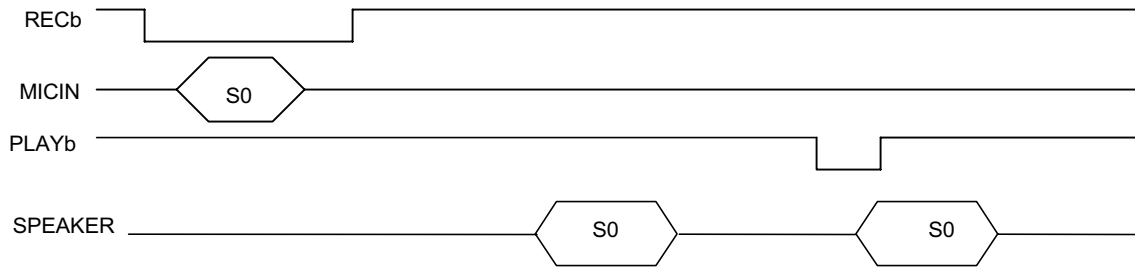

3. Multi Segment Normal mode (TESTb = VDD, AUTO = GND)

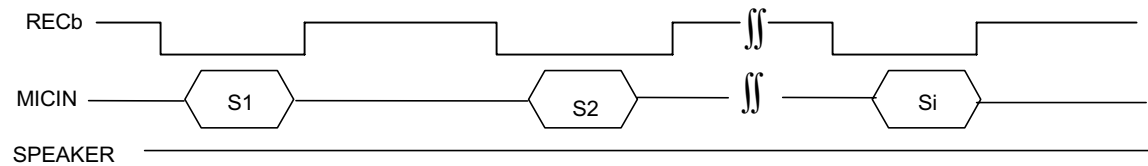



4. Multi Segment AUTO mode (TESTb = VDD, AUTO = VDD)

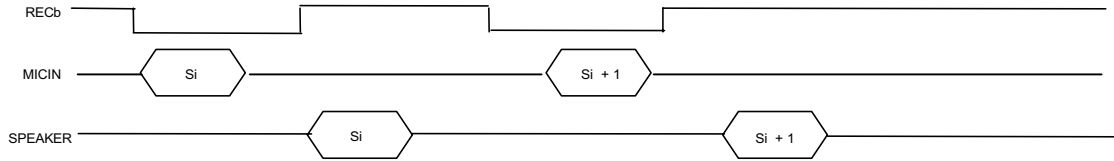

5. Multi Segment Normal Play (TESTb = VDD), AUTO = GND)

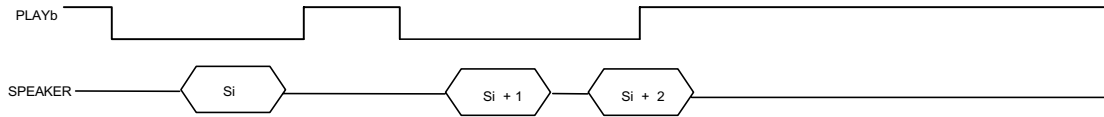

6. Multi Segment Play all (TESTb = VDD)

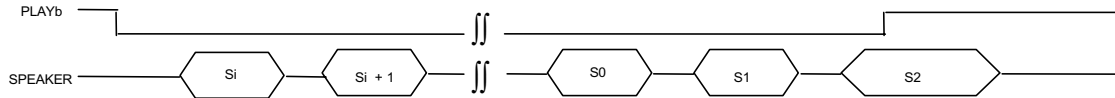

7. Multi Segment ERASE (TESTb)

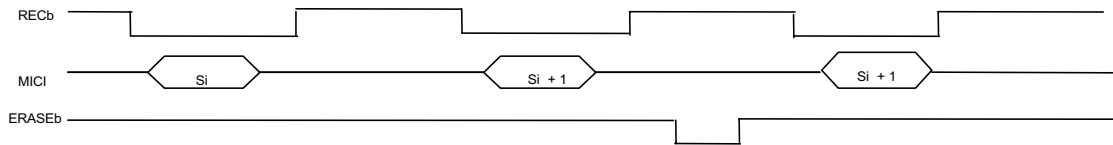



APPLICATION CIRCUIT

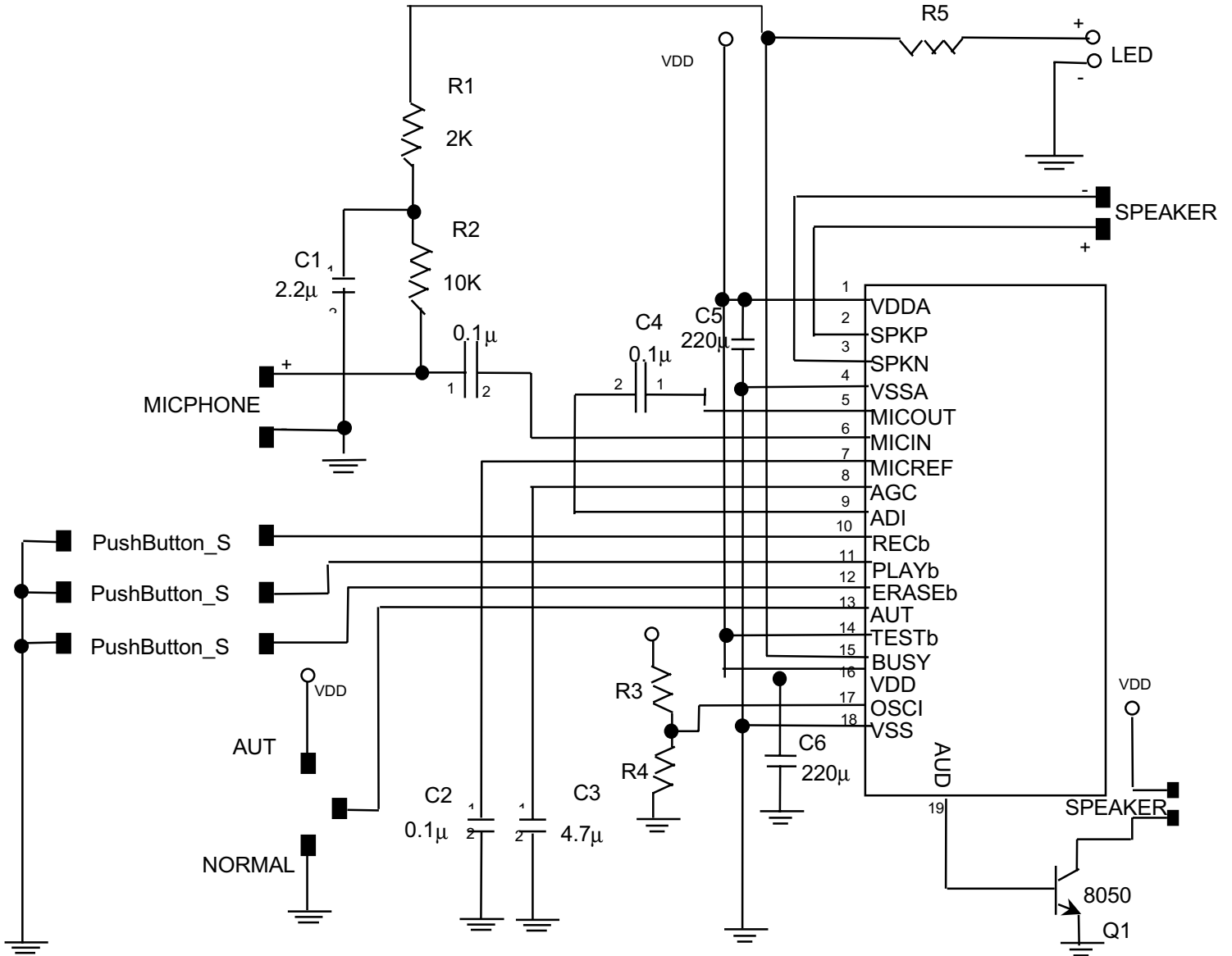

- Note :
1. R3, R4 is used as recording time length fine tune. Default recording length is about 12 sec. don't need R3 or R4. Used R3 make the recording length longer than the default. Used R4 make the recording length shorter than the default.
 2. AGC direct connected to the VSS make the micphone amplifier have maximum and fixed loop gain.
 3. Chip subtract connected to VDD.



PAD LIST

PART NO. : UT53108

PIN NO.	NAME	X	Y	PIN NO.	NAME	X	Y
1	VDDA	105.75	342.75	13	AUTO	2779.6	480.4
2	SPKP	343.35	146.85	14	TESTb	2779.6	605.4
3	SPKN	768.95	146.85	15	BUSY	2779.6	730.4
4	VSSA	1145.8	117.35	16	VDD	2779.6	871.4
5	MICOUT	1292.8	125.25	17	OSCI	2779.6	1001
6	MICIN	1417.8	125.25	18	VSS	2779.6	1204.65
7	MICREF	1542.8	125.25	19	AUD	2779.6	1467.3
8	AGC	1667.8	125.25	20	NC	2779.6	1597.35
9	ADI	1792.8	125.25	21	NC	2779.6	1722.35
10	RECb	2779.6	105.4	22	NC	2779.6	1854.35
11	PLAYb	2779.6	230.4	23	NC	2779.6	1979.55
12	ERASEb	2779.6	355.4				

BONDING DIAGRAM

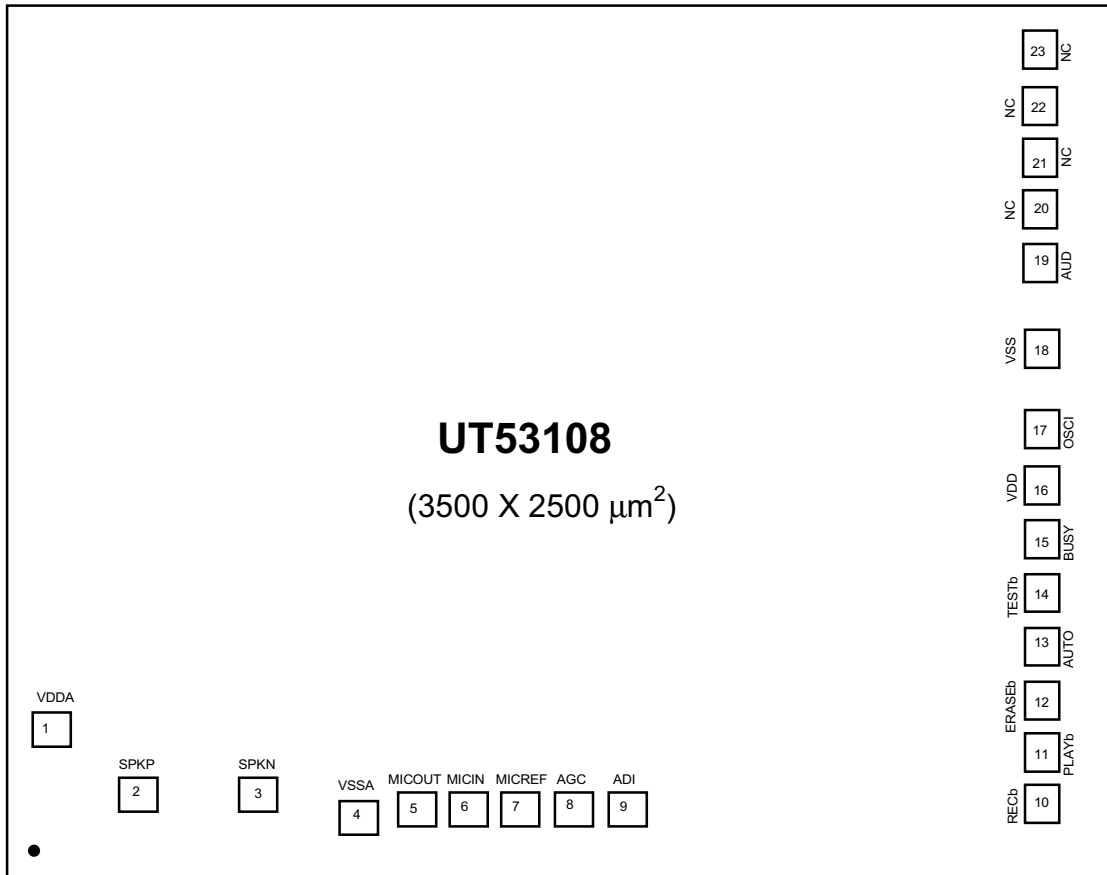



28 pin 330 mil SOP Package Outline Dimension

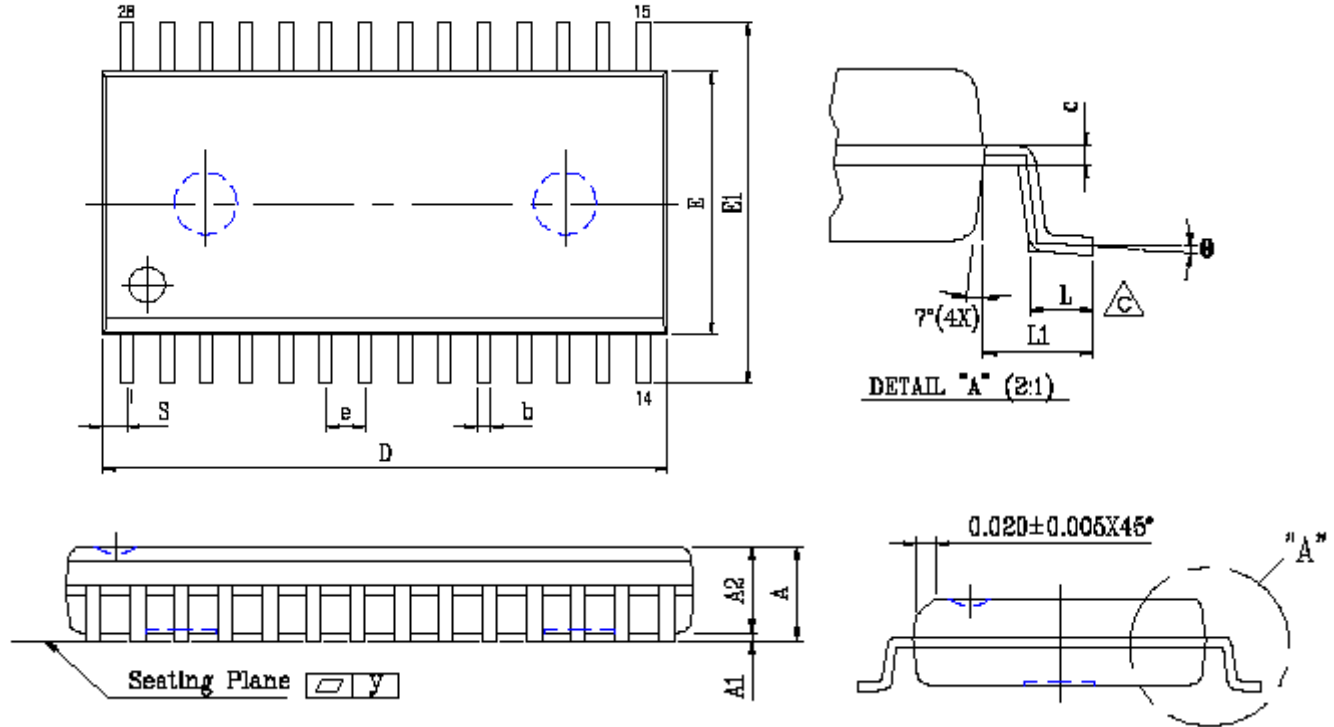

SYMBOL	UNIT	INCH(BASE)	MM(REF)
A		0.120 (MAX)	3.048 (MAX)
A1		0.002(MIN)	0.05(MIN)
A2		0.098± 0.005	2.489± 0.127
b		0.0016 (TYP)	0.406(TYP)
c		0.010 (TYP)	0.254(TYP)
D		0.728 (MAX)	18.491 (MAX)
E		0.0350 (MAX)	8.890 (MAX)
\triangle_B E1		0.465± 0.012	11.811± 0.305
e		0.050 (TYP)	1.270(TYP)
\triangle_C L		0.05 (MAX)	1.270 (MAX)
L1		0.067± 0.008	1.702± 0.203
S		0.047 (MAX)	1.194 (MAX)
\triangle_E y		0.003(MAX)	0.076(MAX)
θ		0° ~ 10°	0° ~ 10°