

DM74LS247

BCD to 7-Segment Decoder/Driver with Open-Collector Outputs

General Description

The 'LS247 has active LOW open-collector outputs guaranteed to sink 24 mA. It has the same electrical characteristics and pin connections as the 'LS47. The only difference is that

the 'LS247 will light the top bar (segment a) for numeral 6 and the bottom bar (segment d) for number 9. For detailed description and specifications please refer to the 'LS47 data sheet.

Connection Diagram

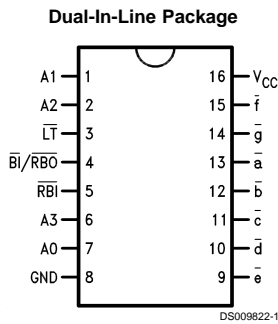

Logic Symbol

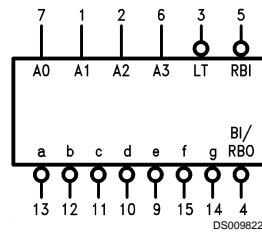

V_{CC} = Pin 16
GND = Pin 8

Order Number DM74LS247M or DM74LS247N
See Package Number M16A or N16E

Pin Names	Description
A0–A3	BCD Inputs
RBI	Ripple Blanking Input (Active LOW)
LT	Lamp Test Input (Active LOW)
BI/RBO	Blanking Input (Active LOW) or Ripple Blanking Output (Active LOW)
a–g	Segment Outputs (Active LOW)

DM74LS247 BCD to 7-Segment Decoder/Driver with Open-Collector Outputs

Absolute Maximum Ratings (Note 1)

Supply Voltage
Input Voltage

7V
7V

Operating Free Air
Temperature Range
Storage Temperature Range

0°C to +70°C
-65°C to +150°C

Recommended Operating Conditions

Symbol	Parameter	Min	Nom	Max	Units
V _{CC}	Supply Voltage	4.75	5	5.25	V
V _{IH}	High Level Input Voltage	2			V
V _{IL}	Low Level Input Voltage			0.8	V
I _{OH}	High Level Output Current $\overline{\text{BI/RBO}}$			-50	μA
I _{OL}	Low Level Output Current			24	mA
T _A	Free Air Operating Temperature	0		70	°C

Note 1: The "Absolute Maximum Ratings" are those values beyond which the safety of the device cannot be guaranteed. The device should not be operated at these limits. The parametric values defined in the "Electrical Characteristics" table are not guaranteed at the absolute maximum ratings. The "Recommended Operating Conditions" table will define the conditions for actual device operation.

Electrical Characteristics

over recommended operating free air temperature range (unless otherwise noted)

Symbol	Parameter	Conditions	Min	Typ (Note 2)	Max	Units	
V _I	Input Clamp Voltage	V _{CC} = Min, I _I = - 18 mA			-1.5	V	
V _{OH}	High Level Output Voltage	V _{CC} = Min, I _{OH} = Max, V _{IL} = Max	2.4	3.4		V	
I _{OFF}	Output High Current Segment Outputs	V _{CC} = 5.5V, V _O = 15V			250	μA	
V _{OL}	Low Level Output Voltage	V _{CC} = Min	I _{OL} = Max, V _{IH} = Min		0.35	0.5	V
			I _{OL} = 3.2 mA	$\overline{\text{BI/RBO}}$			
			I _{OL} = 12 mA	$\overline{\text{a-g}}$	0.25	0.4	
			I _{OL} = 1.6 mA	$\overline{\text{BI/RBO}}$		0.4	
I _I	Input Current @ Max Input Voltage	V _{CC} = Max, V _I = 7V			0.1	mA	
I _{IH}	High Level Input Current	V _{CC} = Max, V _I = 2.7V			20	μA	
I _{IL}	Low Level Input Current	V _{CC} = Max, V _I = 0.4V	Other Inputs		-0.4	mA	
		V _{CC} = Max, V _I = 0.4V	$\overline{\text{BI/RBO}}$ Input				-1.2
I _{OS}	Short Circuit Output Current	V _{CC} = Max (Note 3)	-0.3		-2.0	mA	
I _{CC}	Supply Current	V _{CC} = Max			13	mA	

Note 2: All typicals are at V_{CC} = 5V, T_A = 25°C.

Note 3: Not more than one output should be shorted at a time, and the duration should not exceed one second.

Switching Characteristics

V_{CC} = +5V, T_A = +25°C

Symbol	Parameter	R _L = 2 kΩ		Units
		C _L = 15 pF		
		Min	Max	
t _{PLH}	Propagation Delay Time Low to High Level Output		100	ns
t _{PHL}	Propagation Delay Time High to Low Level Output		100	ns

Physical Dimensions inches (millimeters) unless otherwise noted

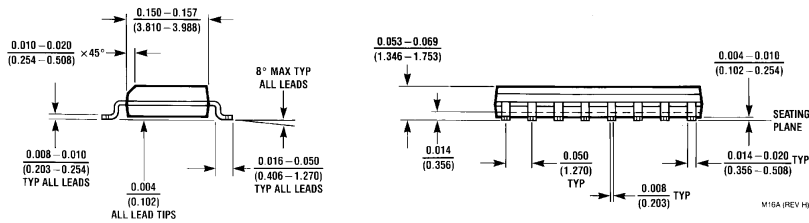
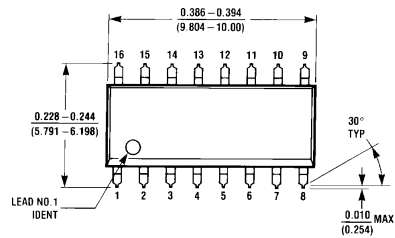

16-Lead Small Outline Molded Package (M)
Order Number DM74LS247M
Package Number M16A

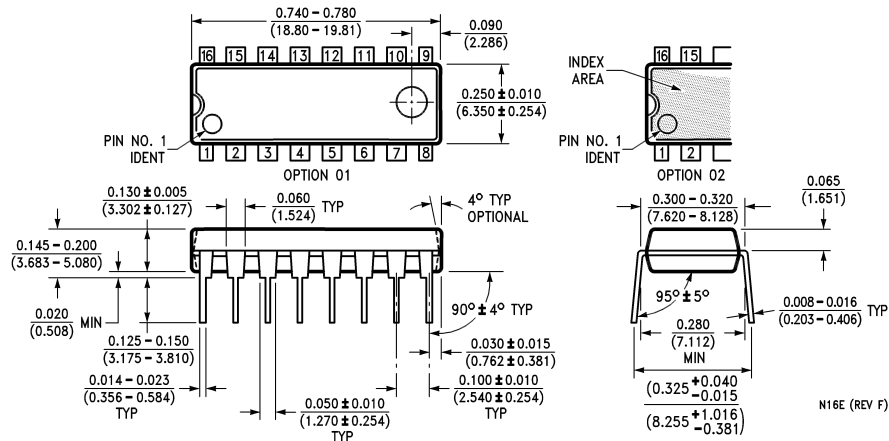

16-Lead Molded Dual-In-Line Package (N)
Order Number DM74LS247N
Package Number N16E

LIFE SUPPORT POLICY

FAIRCHILD'S PRODUCTS ARE NOT AUTHORIZED FOR USE AS CRITICAL COMPONENTS IN LIFE SUPPORT DEVICES OR SYSTEMS WITHOUT THE EXPRESS WRITTEN APPROVAL OF THE PRESIDENT OF FAIRCHILD SEMICONDUCTOR CORPORATION. As used herein:

1. Life support devices or systems are devices or systems which, (a) are intended for surgical implant into the body, or (b) support or sustain life, and (c) whose failure to perform when properly used in accordance with instructions for use provided in the labeling, can be reasonably expected to result in a significant injury to the user.
2. A critical component in any component of a life support device or system whose failure to perform can be reasonably expected to cause the failure of the life support device or system, or to affect its safety or effectiveness.

Fairchild Semiconductor Corporation Americas
Customer Response Center
Tel: 1-888-522-5372

Fairchild Semiconductor Europe
Fax: +49 (0) 1 80-530 85 86
Email: europe.support@nsc.com
Deutsch Tel: +49 (0) 8 141-35-0
English Tel: +44 (0) 1 793-85-68-56
Italy Tel: +39 (0) 2 57 5631

Fairchild Semiconductor Hong Kong Ltd.
13th Floor, Straight Block,
Ocean Centre, 5 Canton Rd.
Tsimshatsui, Kowloon
Hong Kong
Tel: +852 2737-7200
Fax: +852 2314-0061

National Semiconductor Japan Ltd.
Tel: 81-3-5620-6175
Fax: 81-3-5620-6179

www.fairchildsemi.com