

1310nm Laser Diode

Part No.:LD131T10

**Feature**

- Emission Wavelength 1310nm
- Wide Operating Temperature
- High Power
- High Reliable, Long Lifetime
- Lens Output
- Low Threshold, Low Operation Current

**Applications**

- Optical Communication
- Local Area Communication



**Bottom view**

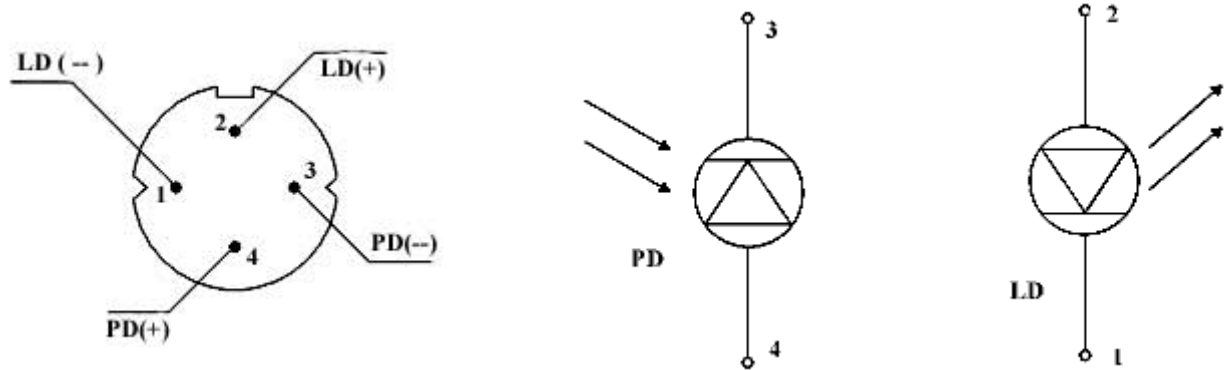

**Absolute Maximum Ratings(Tc=25°C)**

|                       |            |
|-----------------------|------------|
| Output Power          | 10mW       |
| LD Reverse Voltage    | 2V         |
| PD Reverse Voltage    | 10V        |
| PD Forward Current    | 1.0mA      |
| Operation Temperature | -40~+85°C  |
| Storage Temperature   | -40~+100°C |

**Main Specifications (Tc=25°C)**

| PARAMETER          | SYMBOL          | MIN. | Typ. | MAX. | UNIT | TESTING CONDITIONS            |
|--------------------|-----------------|------|------|------|------|-------------------------------|
| Output Power       | P <sub>o</sub>  | -    | 5    | -    | mW   | CW, King free                 |
| Central Wavelength | λ <sub>c</sub>  | 1280 | 1310 | 1340 | nm   | CW, P <sub>o</sub> =5mW       |
| Threshold Current  | I <sub>th</sub> | -    | 8    | 20   | mA   |                               |
| Forward Voltage    | V <sub>f</sub>  | 1.0  | 1.2  | 1.6  | V    | CW, P <sub>o</sub> =5mW       |
| PD Monitor Current | I <sub>m</sub>  | 100  | 300  |      | μ A  | CW, P <sub>o</sub> =5mW       |
| PD Dark Current    | I <sub>d</sub>  | -    | 10   | 100  | nA   | V(PD)= 5V                     |
| Spectral Width     | Δ λ             | -    | 1.5  | 4.0  | nm   | CW, P <sub>o</sub> =5mW       |
| Beam Divergence    | Θ <sub>⊥</sub>  | -    | 40   | -    | deg  | CW, P <sub>o</sub> =5mW, FWHM |
|                    | Θ <sub>//</sub> | -    | 20   | -    |      |                               |
| Rise Time          | t <sub>r</sub>  | -    | 0.3  | 0.7  | ns   | P <sub>o</sub> =5mW ,10%~90%  |
| Fall Time          | t <sub>f</sub>  | -    | 0.3  | 0.7  | ns   | P <sub>o</sub> =5mW ,90%~10%  |

Package Dimensions

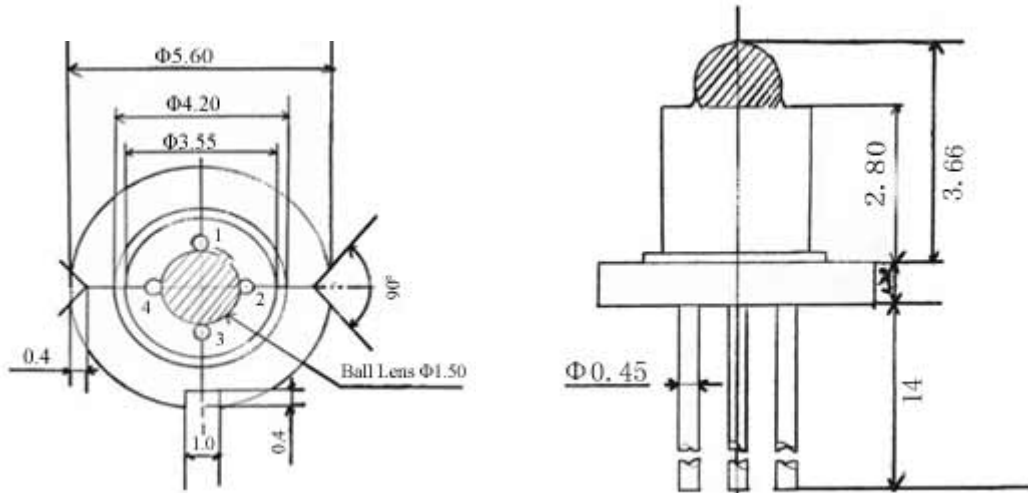

Typical Properties Curves

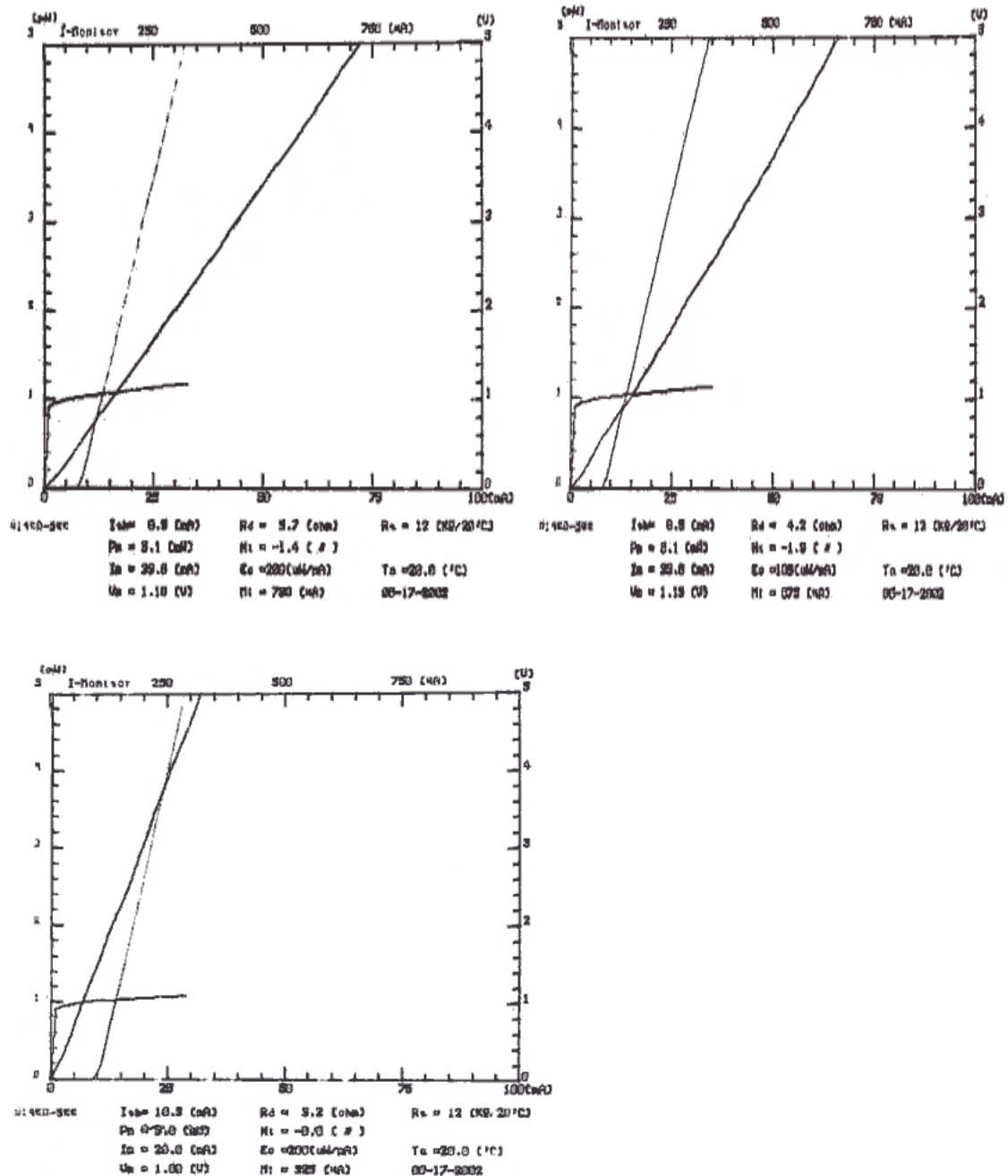

## Operation notes

### 1. Absolute maximum ratings

If an excessively large current flows in a laser diode, a large optical output will occur and the emitting facet may sustain damage. This optical damage can occur even with momentary over-current. For this reason, absolute maximum ratings which must not be exceeded even momentarily have been established. Exercise particular caution with respect to the drive voltage supply and static electricity. We guarantee use within the absolute maximum ratings. These ratings are established for a case temperature of 25\_C. As the temperature of a laser diode increases, its maximum output will decrease and the operating range will shrink. Even when operated within the absolute maximum ratings, operation at high temperature will result in a shorter life than operation at low temperature. For this reason, the design should include sufficient margin for heat radiation and light output.

### 2. Heat radiation conditions

Like other semiconductors, prolonged operation of a laser diode will cause heat to build up at junctions and increased case temperature. For this reason, attach aluminum, copper (or other) heat sinks (at least 30 \_ 30 \_ 3mm) to the stem of the laser.

### 3. Protection against damage due to electrostatic discharge and other current surges

Electrostatic discharge and other current surges can cause deterioration and damage in laser diodes, resulting in reduced reliability. We advise taking the following protective measures :

- 1) Ground the device and circuits. Install surge filters, surge reduction transformers, or other electrostatic discharge protectors in the power supply inputs.
- 2) When working with laser diodes wear anti-static clothing, including footwear and caps. Materials should be selected carefully. Grounded wrist should always be worn while working with laser diodes, and the strap should be grounded through a 1 MΩ resistance.
- 3) Use anti-static containers for transport and storage.
- 4) Laser deterioration and damage can occur due to excessive current spikes when the power is turned on or off. Design circuits to avoid the generation of excessive current spikes.
- 5) Inductive surges near equipment that emits high frequency EMI can damage or destroy lasers. Avoid using lasers near fluorescent lamps or other sources of EMI emissions.

### 4. Soldering

Use a grounded soldering iron to solder laser leads. Solder at a temperature of no more than 250\_C for a maximum of 3 seconds, at a point at least 2 mm from the base of the leads.

### 5. Handling laser diodes

Never touch the glass window of the laser. A damaged or dirtied window will impair the performance of the laser.

### 6. Handling packages

Due to the glass window in each device, packages must not be dropped or subjected to excessive pressure.

### 7. Safety

It is extremely dangerous to look, either directly or through a lens, at the laser beam emitted from a laser diode. Use a TV camera or other similar device to adjust the optical axis.

## Quality assurance

Laser diodes (semiconductor lasers) have a much longer life than other lasers such as gas or solid-state lasers. The components of our lasers have optimum characteristic ranges.

### 1. Quality assurance system

(1) After the wafers have been manufactured, electrical and optical characteristics are measured to verify that characteristics can be achieved as the manufacturing process progresses.

(2) In-process inspections are conducted at various manufacturing points to ensure the stability of our assembly operations.

(3) All products are burned-in to minimize initial and random failures.

(4) Characteristics of all products are tested before shipping.

(5) Products are managed by wafer lot.

(6) Reliability tests are performed on randomly selected samples.

### 2. Quality assurance measures

(1) Materials, manufacturing conditions, and inspection are controlled and maintained based on company set standards. Temperature, dust, humidity and other environmental conditions are also controlled based on company standards.

(2) Measurement instruments used during the manufacturing process are regularly inspected and calibrated based on company measurement control standards.

## Safety

The laser beam emitted from a laser diode is almost invisible to both the human eye and the animal eye, however, it will injure the eye and sufficient caution must be exercised to avoid direct exposure or exposure through a fiber to the beam when a laser diode is in operation.

To adjust the optical axis or perform other similar work, we recommend using an infrared-sensitive ITV camera.

We also recommend that protective glasses be worn.

## Notes

1. No unauthorized transmission or reproduction of this specification, either in whole or in part, is permitted.

2. The contents of this book are subject to change without notice. Always verify before use that the contents are the latest specifications. If, by any chance, a defect should arise in the equipment as a result of use without verification of the specifications, CVC INTERNATIONAL LLC can bear no responsibility whatsoever.

3. Upon the sale of any such devices; other than for the buyer's right to use such devices itself, resell or otherwise dispose of the same; no express or implied right or license to practice or commercially exploit any intellectual property rights or other proprietary rights owned or controlled by CVC INTERNATIONAL LLC is granted to any such buyer.

4. Notes when exporting: Please be sure to consult with our sales representatives to ascertain whether any product is classified as a strategic material.