

DESCRIPTION

RangeMAX Wide Range Dimming, Single Output Inverter. The LXM1612-12-xx series of Direct Drive™ CCFL (Cold Cathode Fluorescent Lamp) Inverter Modules are specifically designed for driving LCD backlight lamps.

Similar to the RangeMAX LXM1611-01 wide range dimming inverter, the LXM1612-12-xx integrates the Direct Drive and brightness control, providing a small form factor, high-efficiency, extended dimming inverter.

Unlike the LXM1610 or any traditional dimming CCFL inverters, the LXM1612-12-xx provides the designer a vastly superior display brightness range. 100:1+ brightness range is achievable with virtually any LCD display. Our wide range dimming provides exceptional display readability at less than 1% of full brightness, allowing both power savings and low ambient light operating capability (i.e. "night readable").

The LXM1612-12-xx is recommended for use in panels with low-voltage insulation on the lamp return wire.

RangeMAX Digital Dimming Technique. Digital dimming provides flicker-free brightness control in any wide-range dimming application. Dimming ratios greater than 100:1 can be achieved. Incorporation of a video synchronization feature allows wide ratio dimming without the display disturbances and interference seen with competitive products.

The modules are equipped with a dimming input that permits brightness

control from either an external potentiometer, DC voltage source, or PWM signal. The resultant "burst drive" that energizes the lamp was designed specifically to ensure that no premature lamp degradation occurs. (See "How RangeMAX Works" Section)

Input Voltage Range. The modules convert DC voltage from the system battery or AC adapter directly to high-frequency, high-voltage waves required to ignite and operate CCFL lamps.

Direct Drive Technology. The module design is based on a new Direct Drive topology, which provides a number of cost and performance advantages. The LXM1612-12-xx series Direct Drive inverters eliminate the classic resonant inductor/capacitors, and integrate the wide range dimming logic into the controller, thus lowering cost, decreasing component count and allowing a substantial reduction in module size.

Additional Features. Other benefits of this new topology are fixed-frequency operation and secondary-side strike-voltage regulation.

Strike-voltage regulation minimizes corona discharge in the output transformer and related circuitry, providing longer life and higher reliability. All LXM1612-12-xx modules feature both open and shorted lamp protection.

The LXM1612-12-xx is fully customizable (electronically and mechanically) to specific customer requirements.

KEY FEATURES

- RangeMAX Wide Range Dimming
- 9.6V to 14.4 V Input Voltage
- Fully Integrated Direct Drive And Dimming Control
- Single Sided PCB Layout
- Easy To Use Brightness Control
- MicroAmp SLEEP Mode
- Output Short-Circuit Protection And Automatic Strike-Voltage Regulation
- Fixed Frequency Operation

APPLICATIONS

- Notebook And Sub-Notebook Computers
- Portable Instrumentation
- Desktop Displays
- Low Ambient Light Conditions (i.e. Aircraft Cabins, Automobile)

BENEFITS

- High Efficiency And Sleep Mode Feature Extends Computer Battery Life
- Smooth, Flicker Free 1-100% Full-Range Brightness Control Gives Your Product A High Quality Image
- Output Open Circuit Voltage Regulation Minimizes Corona Discharge For Long Life And High Reliability
- Power Efficient, "Low Brightness" Capability Allows For Advanced Power Management
- Reduced Component Count For High MTBF Performance

NOTE: For current data & package dimensions, visit our web site: <http://www.linfinity.com>.

MODULE ORDER INFORMATION

| Part Number | Output Connector | Inverter Mates Directly to Panel Connectors |
|---------------|-----------------------|---|
| LXM1612-12-01 | JST SM02(8.0)B-BHS-TB | BHR-03VS-1 |
| LXM1612-12-02 | JST SM02B-BHSS-1-TB | BHSR-02VS-1 |
| LXM1612-12-03 | Honda QZ-19-A3MYL #02 | QZ-19-3F01 |

12V HIGHLY-INTEGRATED, DIGITAL DIMMING CCFL INVERTER MODULE

PRELIMINARY DATA SHEET

ABSOLUTE MAXIMUM RATINGS (Note 1)

| | |
|---|--|
| Input Supply Voltage (V_{IN1}) | -0.3V to 16V |
| Output Voltage, no load | Internally Limited to 1800V _{RMS} |
| Output Current | 8.0mA _{RMS} (Internally Limited) |
| Output Power | 6.0W |
| Input Signal Voltage (BRITE Input) | -0.3V to 5.5V |
| Input Signal Voltage (SLEEP, V_{SYNC} Inputs) | -0.3V to 5.5V |
| Ambient Operating Temperature, zero airflow | 0°C to 70°C |
| Storage Temperature Range | -40°C to 85°C |

Note 1. Exceeding these ratings could cause damage to the device. All voltages are with respect to Ground. Currents are positive into, negative out of the specified terminal.

RECOMMENDED OPERATING CONDITIONS (R.C.)

This module has been designed to operate over a wide range of input and output conditions. However, best efficiency and performance will be obtained if the module is operated under the condition listed in the 'R.C.' column. Min. and Max. columns indicate values beyond which the inverter, although operational, will not function optimally.

| Parameter | Symbol | Recommended Operating Conditions | | | Units |
|--|---------------|----------------------------------|------|------|-------------------|
| | | Min. | R.C. | Max. | |
| Input Supply Voltage Range | V_{IN1} | 9.6 | 12 | 14.4 | V |
| Output Power | P_O | | 3.5 | 4.0 | W |
| Brightness Control Input Voltage Range | $V_{BRT ADJ}$ | 0.0 | 2.5 | 5 | V |
| Lamp Operating Voltage | V_{LAMP} | 300 | 600 | 650 | V _{RMS} |
| Lamp Current (Full Brightness) | I_{OLAMP} | | 5.8 | | mA _{RMS} |
| Operating Ambient Temperature Range | T_A | 0 | | 70 | °C |

ELECTRICAL CHARACTERISTICS

Unless otherwise specified, these specifications apply over the recommended operating conditions and 25°C ambient temperature for the LXM1612-12-xx.

| Parameter | Symbol | Test Conditions | LXM1612-12-xx | | | Units |
|--|------------------|---|---------------|------|-----------|-------------------|
| | | | Min. | Typ. | Max. | |
| Output Pin Characteristics | | | | | | |
| Full Bright Lamp Current | $I_L (MAX)$ | $V_{BRT ADJ} = 2.5V_{DC}$, SLEEP = HIGH, Burst Duty=100%, $V_{IN1} = 12V_{DC}$ | | 5.8 | | mA _{RMS} |
| Min. Average Lamp Current (Note 2) | $I_L (MIN)$ | $V_{BRT ADJ} = 0V_{DC}$, SLEEP = HIGH, Burst Duty = 2.0%, $V_{IN1} = 12V_{DC}$ | | 0.12 | | mA _{RMS} |
| Lamp Start Voltage | V_{LS} | 0°C < T_A < 40°C, $V_{IN1} \geq 9.6V_{DC}$ | 1500 | 1650 | 1800 | V _{RMS} |
| Operating Frequency | f_O | $V_{BRT ADJ} = 2.5V_{DC}$, SLEEP = HIGH, $V_{IN1} = 9.6V - 14.4V$ | 63 | 68 | 73 | KHz |
| BRITE Input | | | | | | |
| Input Current | I_{BRT} | $V_{BRT ADJ} = 0V_{DC}$ | -685 | -728 | -775 | μA_{DC} |
| | | $V_{BRT ADJ} = 2.5V_{DC}$ | -260 | -282 | -305 | μA_{DC} |
| Input Voltage for Max. Lamp Current | $V_{BRT ADJ}$ | $I_O (LAMP) = 100\%$ Duty Cycle | 2.30 | 2.35 | 2.40 | V _{DC} |
| Input Voltage for Min. Lamp Current | $V_{BRT ADJ}$ | $I_O (LAMP) = \text{Minimum Duty Cycle}$ | 0.0 | | | V _{DC} |
| SLEEP Input | | | | | | |
| RUN Mode | $V_{SLEEP (HI)}$ | $V_{IN1} = 12V$ | 1.9 | 2.1 | V_{IN1} | V _{DC} |
| SLEEP Mode | $V_{SLEEP (LO)}$ | $V_{IN1} = 12V$ | -5.0 | 1.9 | 2.0 | V _{DC} |
| Input Current | I_{SLEEP} | SLEEP = 5.0V | 390 | 410 | 435 | μA_{DC} |
| | | SLEEP = 0V | 0.0 | 0.0 | 0.0 | μA_{DC} |
| V_{SYNC} Characteristics | | | | | | |
| Logic High Level | $V_{SYNC (HI)}$ | $V_{IN1} = 12V$ | 1.50 | 2.5 | 5.0 | V _{DC} |
| Logic Low Level | $V_{SYNC (LO)}$ | $V_{IN1} = 12V$ | -3.0 | 0.0 | 1.2 | V _{DC} |
| Input Impedance | Z_{IN} | | 25 | 27 | 29 | k Ω |
| Input Frequency | f_{SYNC} | | 20 | | 200 | Hz |
| Power Characteristics | | | | | | |
| Sleep Current | $I_{IN (MIN)}$ | $V_{IN1} = 12V_{DC}$, SLEEP = 0.0V | 0.0 | 0.5 | 10 | μA_{DC} |

Note 2. Minimum lamp current required to maintain even light output may vary with display panel.
Average RMS current = (burst duty cycle) x (burst amplitude of 5.8mA_{RMS})

12V HIGHLY-INTEGRATED, DIGITAL DIMMING CCFL INVERTER MODULE

PRELIMINARY DATA SHEET

FUNCTIONAL PIN DESCRIPTION

| Conn. | Pin | Description |
|---|-------------------|---|
| CN1 (Molex 53261-0890) Mates with 51021-0800 housing, 50079-8100 pins | | |
| CN1-1 CN1-2 | V _{IN1} | Main Input Power Supply. ($9.6V \leq V_{IN1} \leq 14.4V$) |
| CN1-3 CN1-4 | GND | Power Supply Return. |
| CN1-5 | SLEEP | ON/OFF Control. ($2.1V < \overline{SLEEP} < V_{IN1} = \text{ON}$, $0V < \overline{SLEEP} < 0.8V = \text{OFF}$, SLEEP Floating = OFF) |
| CN1-6 | BRITE | Brightness Control (0.0V to $2.5V_{DC}$). $2.5V_{DC}$ gives maximum lamp current. |
| CN1-7 | BRITE RTN | Analog Ground. Use for BRITE signal return ONLY. |
| CN1-8 | V _{SYNC} | Vertical Synchronization Input. 2.5 to 5.0V Logic Level. ($20Hz < f_{SYNC} < 200Hz$) |
| CN2 for LXM1612-12-01 and -02 (JST SM02(8.0)B-BHS-TB or SM02B-BHSS-1-TB) | | |
| CN2-1 | V _{HI} | High voltage connection to high side of lamp. Connect to lamp terminal with shortest lead length. DO NOT connect to Ground. |
| CN2-2 | V _{LO} | Connection to low side of lamp. Connect to lamp terminal with longer lead length. DO NOT connect to Ground. |
| CN2 for LXM1612-12-03 (Honda QZ-19-AMYL#02) | | |
| CN2-3 | V _{HI} | High voltage connection to high side of lamp. Connect to lamp terminal with shortest lead length. DO NOT connect to Ground. |
| CN2-1 | V _{LO} | Connection to low side of lamp. Connect to lamp terminal with longer lead length. DO NOT connect to Ground. |

PHYSICAL DIMENSIONS

LXM1612-12-xx All dimensions are in inches (mm).

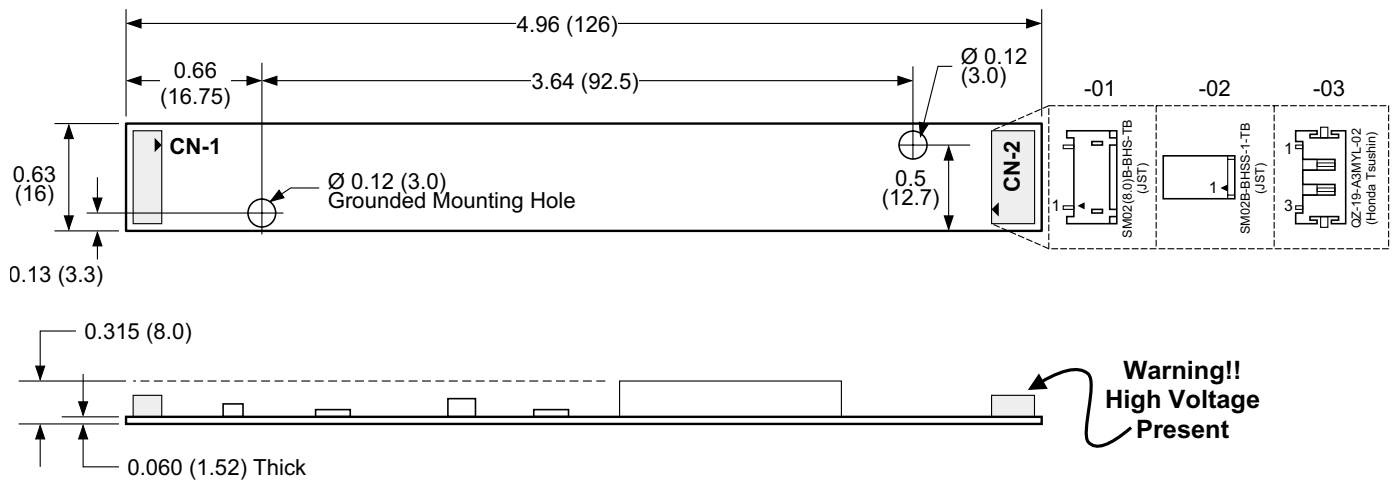

Note: Linfinity offers an input cable assembly, the LX9501, which includes the mate for the Molex input connector (CN1) with 18" of pre-stripped color coded AWG#26 wire.

HOW RANGEMAX WORKS

LAMP VOLTAGE & LAMP CURRENT — Burst Mode Operation

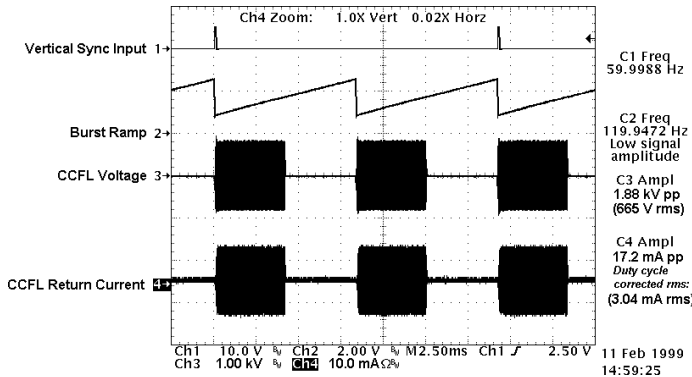

FIGURE 1 — 50% Burst Duty Cycle

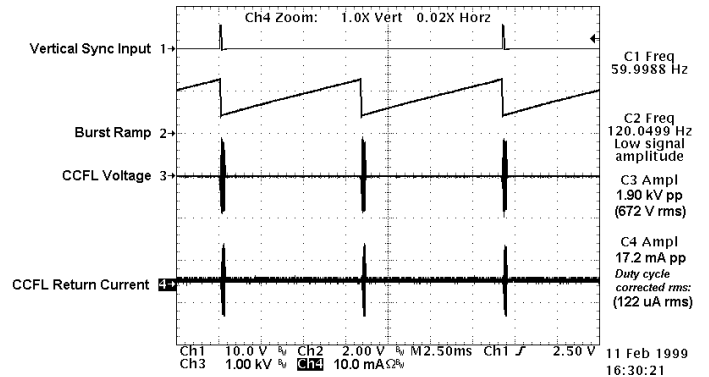

FIGURE 2 — 2% Burst Duty Cycle

Rather than using the traditional dimming technique of varying lamp current magnitude to adjust light output, RangeMAX inverters use a fixed lamp current value with a duty cycle control method.

The lamp current burst width can be modulated from 100% (continuous lamp current) down to a 2% duty cycle, allowing the lamp to be dimmed to less than 1% of its full brightness.

As can be seen in Trace 4 of Figure 3 photo at right, careful design consideration was given to controlling lamp start voltage to softly start current flow. This eliminates current overshoot that can result in premature cathode wear and reduce lamp life.

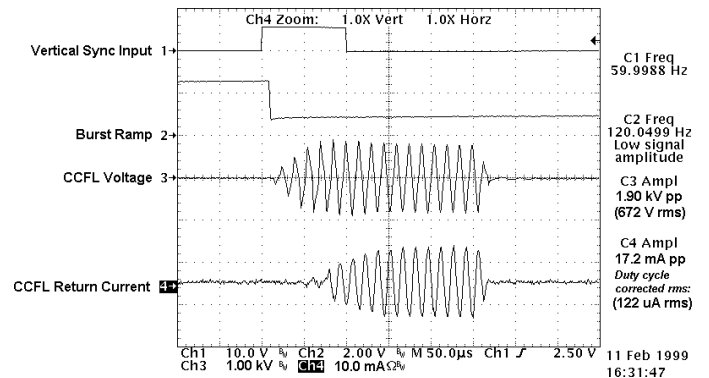

FIGURE 3 — 2% Burst Duty Cycle (Expanded Time Base)

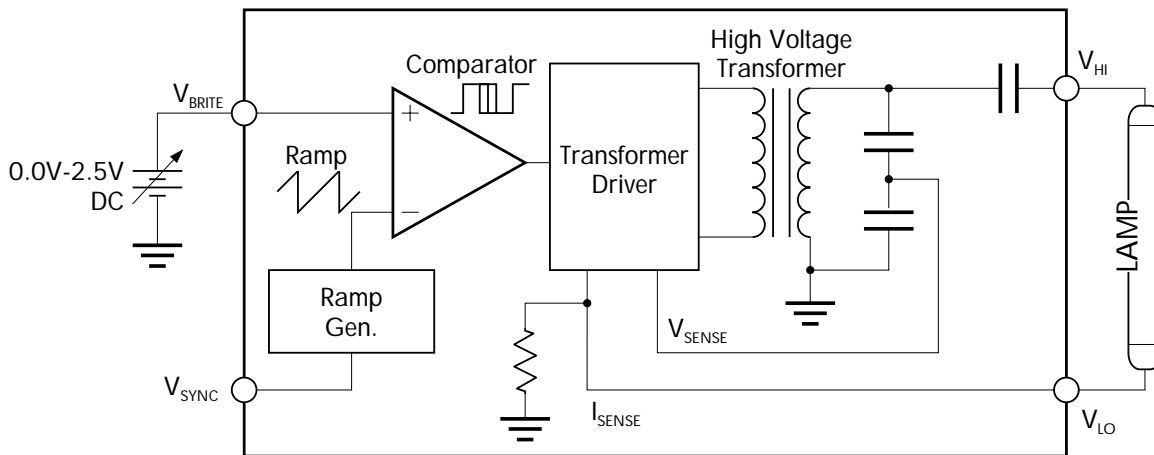

FIGURE 4 — RangeMAX Block Diagram

12V HIGHLY-INTEGRATED, DIGITAL DIMMING CCFL INVERTER MODULE

PRELIMINARY DATA SHEET

HOW RANGEMAX WORKS (continued)

HIGHLIGHTS

- Integrated brightness control circuit includes a DC voltage to pulse width converter that minimizes system design work and system noise susceptibility. This provides a familiar and convenient interface while reducing the potential for externally induced noise which can cause lamp flicker.
- RangeMAX inverter modules are designed to operate with the burst frequency synchronized to the video frame rate. This provides operation with no visible display disturbances caused by beat frequencies between the lamps and video frame rates. In this synchronous mode, the inverter burst rate operates at twice the video refresh rate, well beyond standard 50/60Hz video refresh rates where the eye can perceive pulsing light.
- In applications with no access to a vertical sync, an on-board oscillator operates the inverter burst rate at 250Hz. In this non-synchronous mode, minor display disturbances can be found under certain video conditions. This performance may be acceptable for many applications, but synchronization must be used when no disturbance can be tolerated.
- A single input will accommodate negative and positive vertical sync pulses at any pulse width.
- Separate feedback loops for lamp current and open circuit voltage regulation insure reliable strike under all operating conditions, automatic over-voltage prevention with broken or failed lamps, and accurate lamp current regulation.

TYPICAL APPLICATION

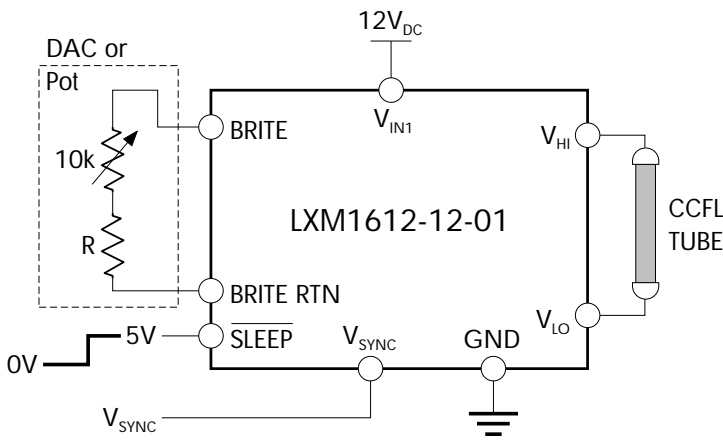

FIGURE 5 — Potentiometer Brightness Control

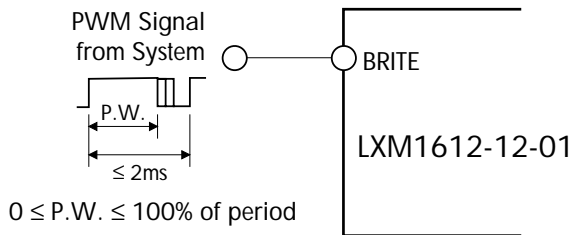

FIGURE 5A — PWM Brightness Control

- The brightness control may be a voltage output DAC, digital resistor or a simple 10k potentiometer. If desired, an additional series resistor with the 10k potentiometer can be used to set a higher minimum brightness setting as shown in Figure 5. A 2.5V to 5V Logic Level PWM signal from a micro-controller may also be used as shown in Figure 5A.
- If synchronization to the video framerate is desired, connect the vertical sync pulse from the system video controller to the V_{SYNC} input. If no video synchronization is desired, connect V_{SYNC} to ground.
- If you need to turn the inverter ON/OFF remotely, connect a 2.5V to 5V logic signal to the $SLEEP$ input.
- Connect V_{HI} to high voltage wire from the lamp. Connect V_{LO} to the low voltage wire (wire with thinner insulation). Never connect V_{LO} to circuit ground as this will defeat lamp current regulation. If both lamp wires have heavy high voltage insulation, connect the longest wire to V_{LO} . This wire is typically white.

RangeMAX INVERTERS

Also available in Wide Input Voltage, Dual Output **LXM1621-01** and Quad Output **LXM1641-01** versions for multiple lamp applications.

RangeMAX and Direct Drive are trademarks of Linfinity Microelectronics Inc.

PRELIMINARY DATA - Information contained in this document is pre-production data, and is proprietary to Linfinity. It may not be modified in any way without the express written consent of Linfinity. Product referred to herein is offered in sample form only, and Linfinity reserves the right to change or discontinue this proposed product at any time.