

TOSHIBA ALLOY-FREE LIGHT TRIGGER THYRISTOR

SL1500GX24

HIGH POWER CONTROL APPLICATIONS

- Repetitive Peak Off-State Voltage : V_{DRM}
- Repetitive Peak Reverse Voltage : V_{RRM}
- Average On-State Current : $I_T(AV) = 1500A$
- Light Trigger Power : $P_{LT} : 10mW (Max.)$
- Turn-Off Time : $t_q = 400\mu s (Max.)$
- Critical Rate of Rise of On-State Current : $di / dt = 250A / \mu s$
- Critical Rate of Rise of Off-State Voltage : $dv / dt = 1500V / \mu s$
- Flat Package

MAXIMUM RATINGS

CHARACTERISTIC	SYMBOL	RATING	UNIT
Repetitive Peak Off-State Voltage and Repetitive Peak Reverse Voltage	V_{DRM} V_{RRM}	4000	V
Non-Repetitive Peak Reverse Voltage (Non-Repetitive $\leq 5ms, T_j = 0 \sim 125^\circ C$)	V_{RSM}	4400	V
R.M.S On-State Current	$I_T(RMS)$	2355	A
Average On-State Current	$I_T(AV)$	1500	A
Peak One Cycle Surge On-State Current (Non-Repetitive)	I_{TSM}	30000 (50Hz) 33000 (60Hz)	A
I^2t Limit Value	I^2t	4500×10^3	A^2s
Critical Rate of Rise of On-State Current (Note)	di / dt	250	$A / \mu s$
Junction Temperature	T_j	$-40 \sim 125$	$^\circ C$
Storage Temperature Range	T_{stg}	$-40 \sim 125$	$^\circ C$
Mounting Force	—	39.2 ± 3.9	kN

Note : $V_D = 2000V, f = 50Hz, T_j = 120^\circ C$

Unit in mm

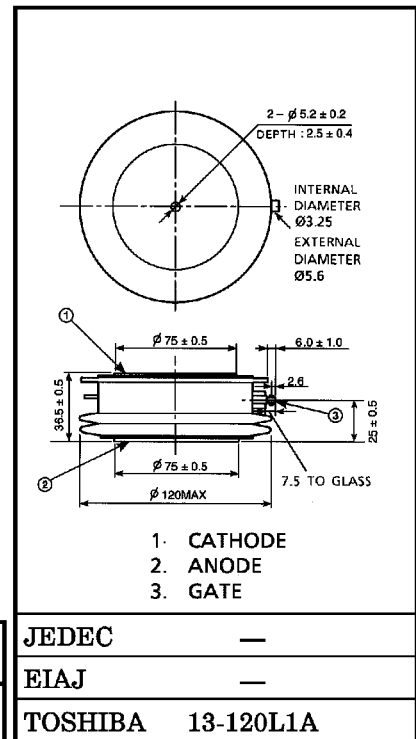

Weight : 1700g

961001EAA1

- TOSHIBA is continually working to improve the quality and the reliability of its products. Nevertheless, semiconductor devices in general can malfunction or fail due to their inherent electrical sensitivity and vulnerability to physical stress. It is the responsibility of the buyer, when utilizing TOSHIBA products, to observe standards of safety, and to avoid situations in which a malfunction or failure of a TOSHIBA product could cause loss of human life, bodily injury or damage to property. In developing your designs, please ensure that TOSHIBA products are used within specified operating ranges as set forth in the most recent products specifications. Also, please keep in mind the precautions and conditions set forth in the TOSHIBA Semiconductor Reliability Handbook.
- The information contained herein is presented only as a guide for the applications of our products. No responsibility is assumed by TOSHIBA CORPORATION for any infringements of intellectual property or other rights of the third parties which may result from its use. No license is granted by implication or otherwise under any intellectual property or other rights of TOSHIBA CORPORATION or others.
- The information contained herein is subject to change without notice.

ELECTRICAL CHARACTERISTICS

CHARACTERISTIC	SYMBOL	TEST CONDITION	MIN.	MAX.	UNIT
Repetitive Peak Off-State Current and Repetitive Peak Reverse Current	I_{DRM} I_{RRM}	$V_{DRM} = V_{RRM} = 4000V$ $T_j = 125^\circ C$	—	120	mA
Peak On-State Voltage	V_{TM}	$I_{TM} = 5000A, T_j = 25^\circ C$	—	2.3	V
Light Trigger Power	P_{LT}	$V_D = 12V, R_L = 6\Omega$	$T_j = -40^\circ C$	—	mW
			$T_j = 25^\circ C$	—	
Delay Time	t_d	$V_D = 2000V, T_j = 25^\circ C$	—	4	μs
Gate Turn-On Time	t_{gt}	$P_L = 20mW$	—	6	μs
Turn-Off Time	t_q	$I_T = 1200A, V_R \geq 200V$ $dv/dt = 25V/\mu s, T_j = 115^\circ C$ $V_{DRM} = 2000V$	—	400	μs
Holding Current	I_H	$T_j = 25^\circ C, R_L = 6\Omega$	—	300	mA
Critical Rate of Rise of Off-State Voltage	dv/dt	$V_{DRM} = 2000V, T_j = 125^\circ C$ Gate Open, Exponential Rise	1500	—	$V/\mu s$
Thermal Resistance (Junction to Case)	$R_{th(j-f)}$	DC	—	0.02	$^\circ C/W$

