

PROTECTION PRODUCTS

Description

RailClamps are surge rated diode arrays designed to protect high speed data interfaces. The SR series has been specifically designed to protect sensitive components which are connected to data and transmission lines from overvoltage caused by ESD (electrostatic discharge), EFT (electrical fast transients), and lightning.

The unique design of the SR series devices incorporates four surge rated, low capacitance steering diodes and a TVS diode in a single package. During transient conditions, the steering diodes direct the transient to either the positive side of the power supply line or to ground. The internal TVS diode prevents over-voltage on the power line, protecting any downstream components.

The low capacitance array configuration allows the user to protect two high-speed data or transmission lines. The low inductance construction minimizes voltage overshoot during high current surges.

Features

- ◆ ESD protection to IEC 61000-4-2, Level 4
- ◆ Array of surge rated diodes with internal TVS Diode
- ◆ Protects two I/O lines
- ◆ Low capacitance (<10pF) for high-speed interfaces
- ◆ Low clamping voltage
- ◆ Low operating voltage: 5.0V
- ◆ Solid-state silicon-avalanche technology

Mechanical Characteristics

- ◆ JEDEC SOT-143 package
- ◆ UL 497B listed
- ◆ Molding compound flammability rating: UL 94V-0
- ◆ Marking : R05
- ◆ Packaging : Tape and Reel per EIA 481

Applications

- ◆ USB Power & Data Line Protection
- ◆ Ethernet 10BaseT
- ◆ I<sup>2</sup>C Bus Protection
- ◆ Video Line Protection
- ◆ T1/E1 secondary IC Side Protection
- ◆ Portable Electronics
- ◆ Microcontroller Input Protection
- ◆ WAN/LAN Equipment
- ◆ ISDN S/T Interface

Circuit Diagram

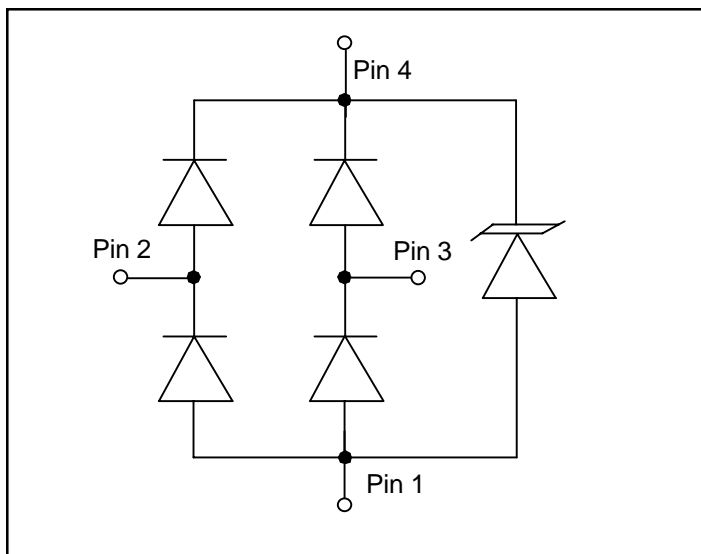

Schematic & PIN Configuration

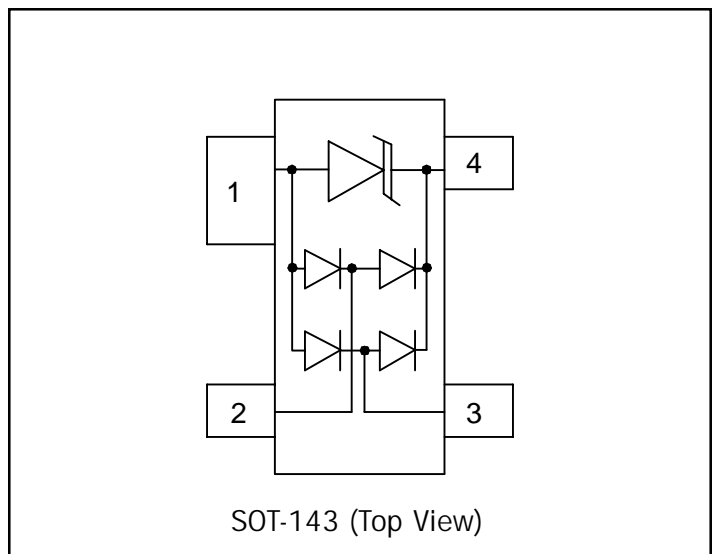

## PROTECTION PRODUCTS

## Absolute Maximum Rating

Rating	Symbol	Value	Units
Peak Pulse Power (tp = 8/20μs)	$P_{pk}$	500	Watts
Peak Pulse Current (tp = 8/20μs)	$I_{pp}$	25	A
Peak Forward Voltage ( $I_f = 1A$ , tp=8/20μs)	$V_{FP}$	1.5	V
Lead Soldering Temperature	$T_L$	260 (10 sec.)	°C
Operating Temperature	$T_J$	-55 to +125	°C
Storage Temperature	$T_{STG}$	-55 to +150	°C

## Electrical Characteristics

SR05						
Parameter	Symbol	Conditions	Minimum	Typical	Maximum	Units
Reverse Stand-Off Voltage	$V_{RWM}$				5	V
Reverse Breakdown Voltage	$V_{BR}$	$I_t = 1mA$	6			V
Reverse Leakage Current	$I_R$	$V_{RWM} = 5V, T=25°C$			5	μA
Clamping Voltage	$V_C$	$I_{pp} = 1A, tp = 8/20μs$			9.8	V
Clamping Voltage	$V_C$	$I_{pp} = 10A, tp = 8/20μs$			12	V
Clamping Voltage	$V_C$	$I_{pp} = 25A, tp = 8/20μs$			20	V
Junction Capacitance	$C_J$	Between I/O pins and Gnd $V_R = 0V, f = 1MHz$		6	10	pF
		Between I/O pins $V_R = 0V, f = 1MHz$		3		pF

PROTECTION PRODUCTS

Typical Characteristics

Non-Repetitive Peak Pulse Power vs. Pulse Time

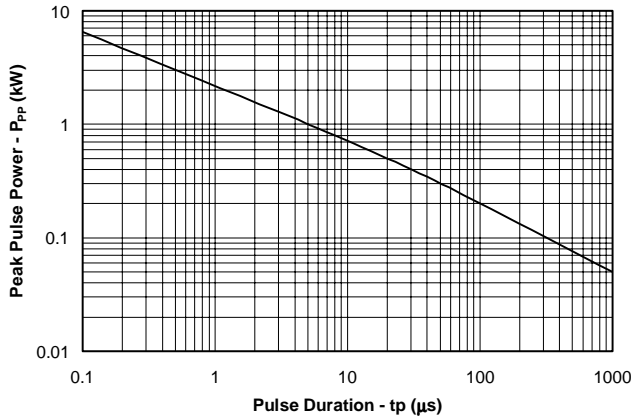

Power Derating Curve

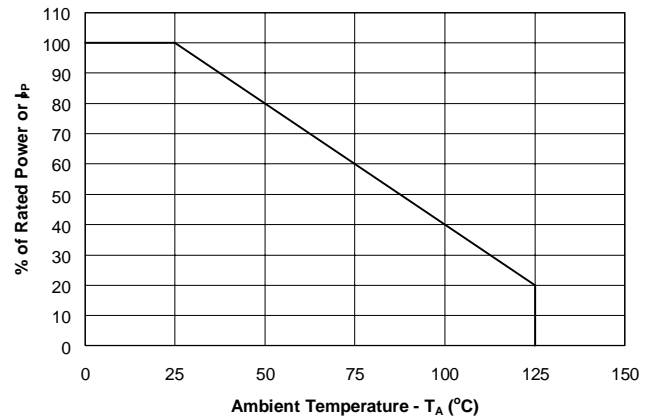

Pulse Waveform

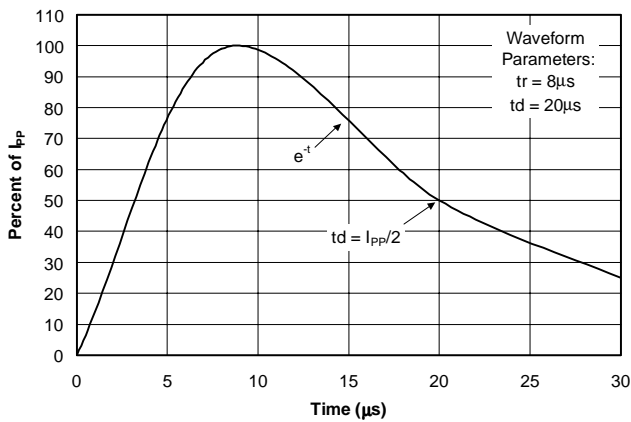

Clamping Voltage vs. Peak Pulse Current

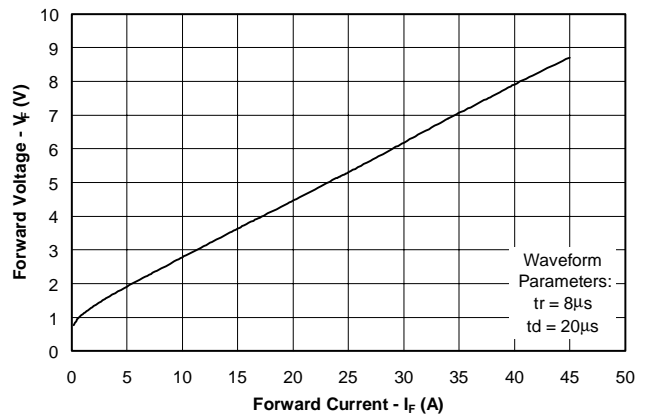

Forward Voltage vs. Forward Current

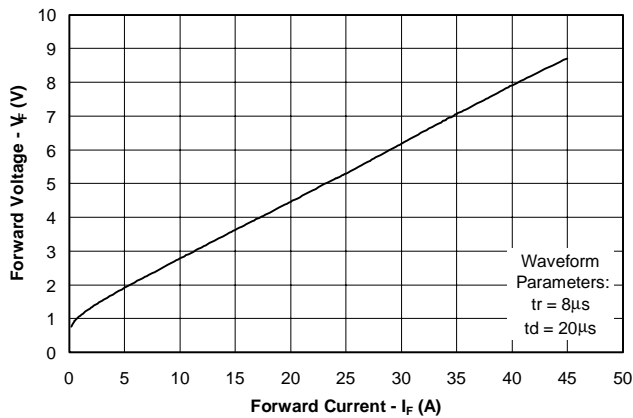

Capacitance vs. Reverse Voltage

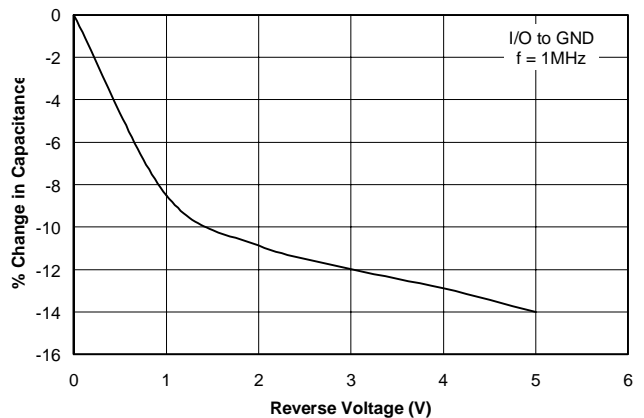

PROTECTION PRODUCTS

Applications Information

Device Connection Options for Protection of Two High-Speed Data Lines

The SR05 TVS is designed to protect two data lines from transient over-voltages by clamping them to a fixed reference. When the voltage on the protected line exceeds the reference voltage (plus diode  $V_F$ ) the steering diodes are forward biased, conducting the transient current away from the sensitive circuitry. Data lines are connected at pins 2 and 3. The negative reference (REF1) is connected at pin 1. This pin should be connected directly to a ground plane on the board for best results. The path length is kept as short as possible to minimize parasitic inductance.

The positive reference (REF2) is connected at pin 4. The options for connecting the positive reference are as follows:

1. To protect data lines and the power line, connect pin 4 directly to the positive supply rail ( $V_{CC}$ ). In this configuration the data lines are referenced to the supply voltage. The internal TVS diode prevents over-voltage on the supply rail.
2. The SR05 can be isolated from the power supply by adding a series resistor between pin 4 and  $V_{CC}$ . A value of  $10k\Omega$  is recommended. The internal TVS and steering diodes remain biased, providing the advantage of lower capacitance.
3. In applications where no positive supply reference is available, or complete supply isolation is desired, the internal TVS may be used as the reference. In this case, pin 4 is not connected. The steering diodes will begin to conduct when the voltage on the protected line exceeds the working voltage of the TVS (plus one diode drop).

ESD Protection With RailClamps

RailClamps are optimized for ESD protection using the rail-to-rail topology. Along with good board layout, these devices virtually eliminate the disadvantages of using discrete components to implement this topology. Consider the situation shown in Figure 1 where discrete diodes or diode arrays are configured for rail-to-rail protection on a high speed line. During positive duration ESD events, the top diode will be forward biased when the voltage on the protected line exceeds the reference voltage plus the  $V_F$  drop of the diode.

Data Line and Power Supply Protection Using  $V_{CC}$  as reference

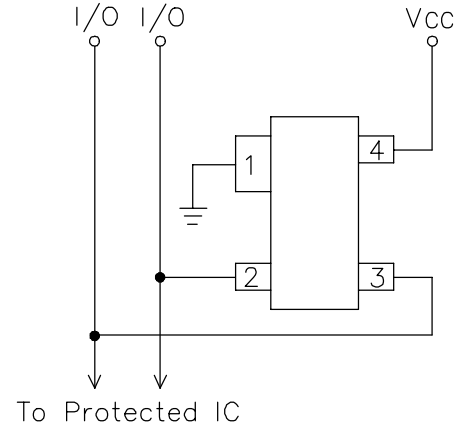

Data Line Protection with Bias and Power Supply Isolation Resistor

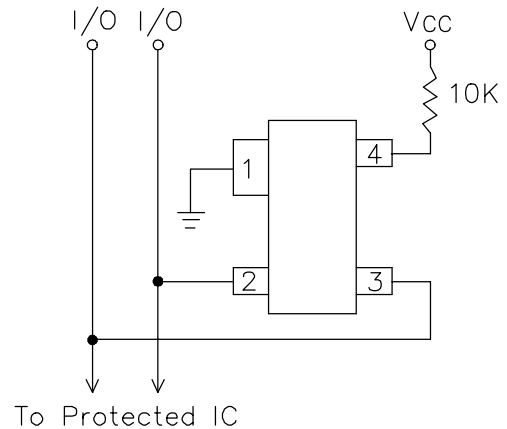

Data Line Protection Using Internal TVS Diode as Reference

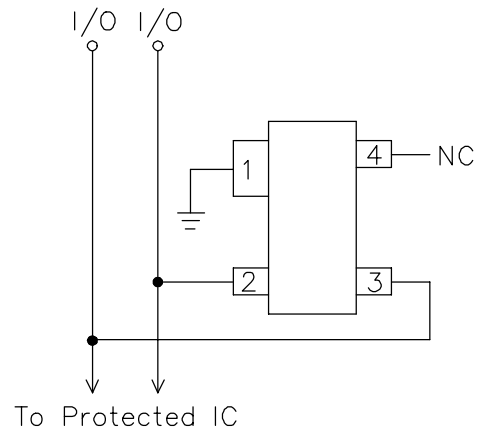

PROTECTION PRODUCTS

Applications Information (continued)

For negative events, the bottom diode will be biased when the voltage exceeds the  $V_F$  of the diode. At first approximation, the clamping voltage due to the characteristics of the protection diodes is given by:

$$V_C = V_{CC} + V_F \quad (\text{for positive duration pulses})$$

$$V_C = -V_F \quad (\text{for negative duration pulses})$$

However, for fast rise time transient events, the effects of parasitic inductance must also be considered as shown in Figure 2. Therefore, the actual clamping voltage seen by the protected circuit will be:

$$V_C = V_{CC} + V_F + L_P di_{ESD}/dt \quad (\text{for positive duration pulses})$$

$$V_C = -V_F - L_G di_{ESD}/dt \quad (\text{for negative duration pulses})$$

ESD current reaches a peak amplitude of 30A in 1ns for a level 4 ESD contact discharge per IEC 1000-4-2. Therefore, the voltage overshoot due to 1nH of series inductance is:

$$V = L_P di_{ESD}/dt = 1 \times 10^{-9} (30 / 1 \times 10^{-9}) = 30V$$

Example:

Consider a  $V_{CC} = 5V$ , a typical  $V_F$  of 30V (at 30A) for the steering diode and a series trace inductance of 10nH. The clamping voltage seen by the protected IC for a positive 8kV (30A) ESD pulse will be:

$$V_C = 5V + 30V + (10nH \times 30V/nH) = 335V$$

This does not take into account that the ESD current is directed into the supply rail, potentially damaging any components that are attached to that rail. Also note that it is not uncommon for the  $V_F$  of discrete diodes to exceed the damage threshold of the protected IC. This is due to the relatively small junction area of typical discrete components. It is also possible that the power dissipation capability of the discrete diode will be exceeded, thus destroying the device.

The RailClamp is designed to overcome the inherent disadvantages of using discrete signal diodes for ESD suppression. The RailClamp's integrated TVS diode helps to mitigate the effects of parasitic inductance in

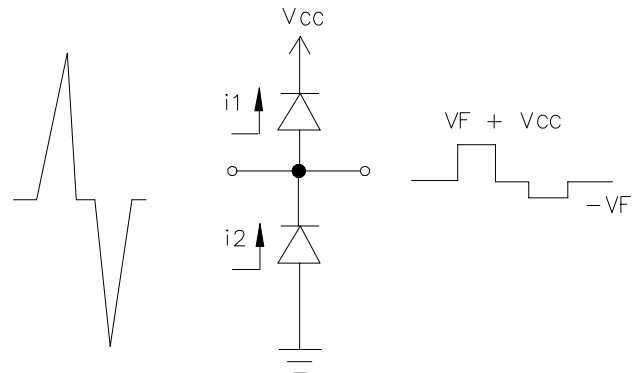

Figure 1 - "Rail-To-Rail" Protection Topology (First Approximation)

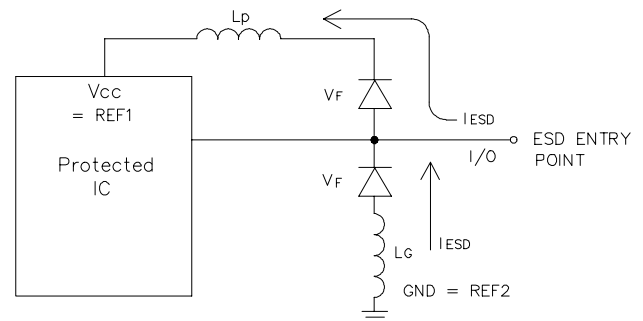

Figure 2 - The Effects of Parasitic Inductance When Using Discrete Components to Implement Rail-To-Rail Protection

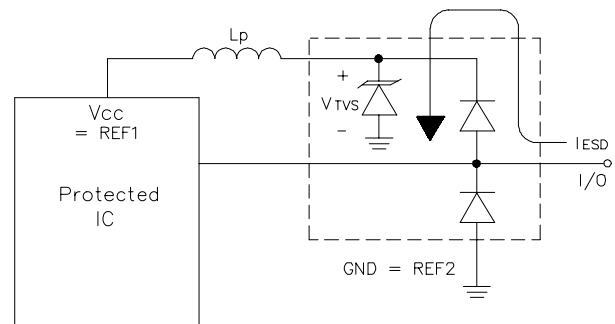

Figure 3 - Rail-To-Rail Protection Using RailClamp TVS Arrays

**PROTECTION PRODUCTS****Applications Information (*continued*)**

the power supply connection. During an ESD event, the current will be directed through the integrated TVS diode to ground. The total clamping voltage seen by the protected IC due to this path will be:

$$V_C = V_{F(\text{RailClamp})} + V_{\text{TVS}}$$

This is given in the data sheet as the rated clamping voltage of the device. For a SR05 the typical clamping voltage is <16V at  $I_{pp}=30A$ . The diodes internal to the RailClamp are low capacitance, fast switching devices that are rated to handle transient currents and maintain excellent forward voltage characteristics.

#### Universal Serial Bus ESD Protection

The figure below illustrates how to use the SR05 to protect one upstream USB port and the SRDA05-4 to protect two downstream USB ports. When the voltage on the data lines exceed the bus voltage (plus one diode drop), the internal rectifiers are forward biased conducting the transient current away from the protected controller chip. The TVS diode directs the surge to ground. The TVS diode also acts to suppress ESD strikes directly on the voltage bus. Thus, both power and data pins are protected with a single device. Reference Semtech application note SI96-18 for further information.

PROTECTION PRODUCTS

Typical Applications

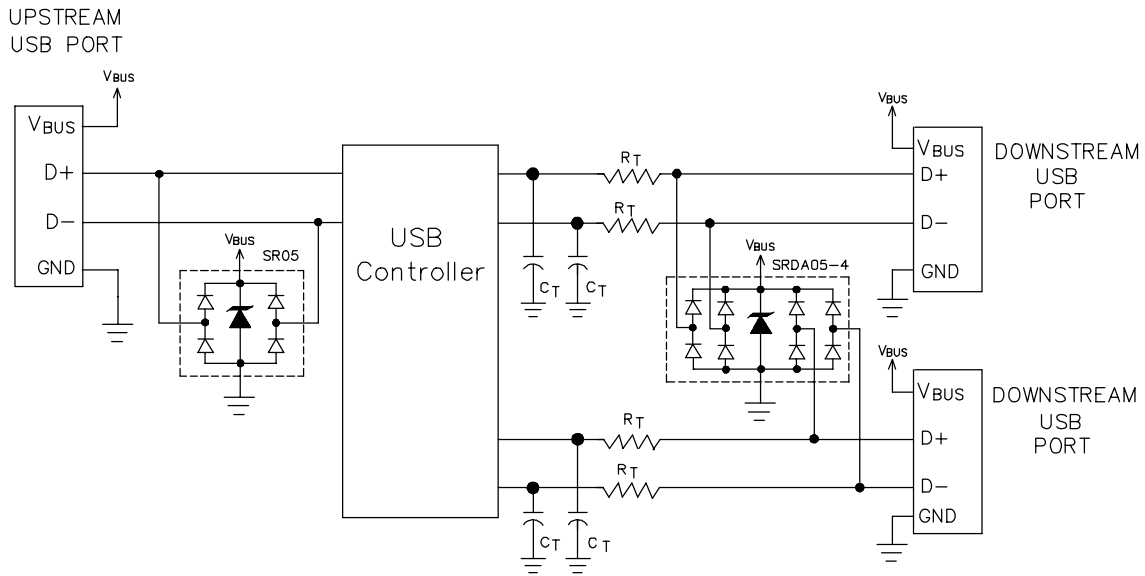

Universal Serial Bus ESD Protection

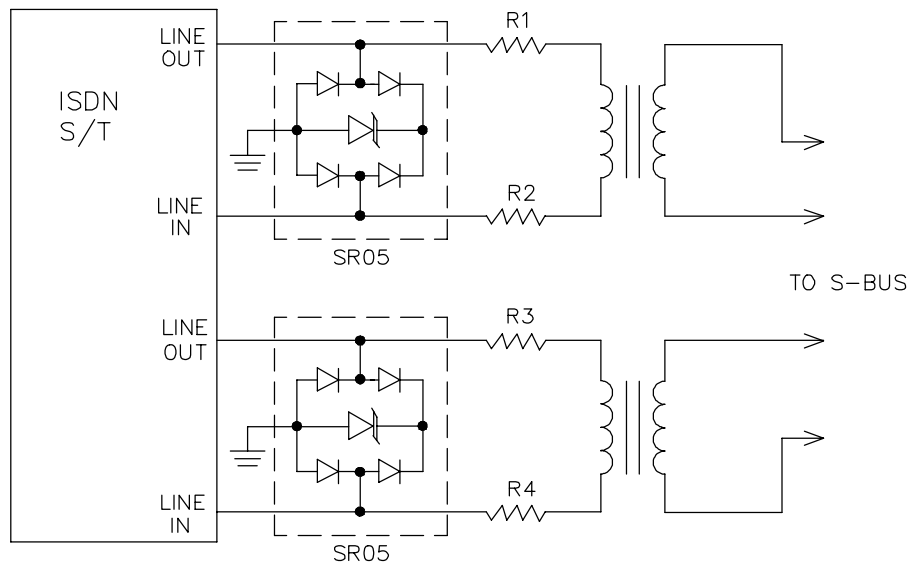

ISDN S/T Interface Protection

PROTECTION PRODUCTS

Outline Drawing - SOT-143

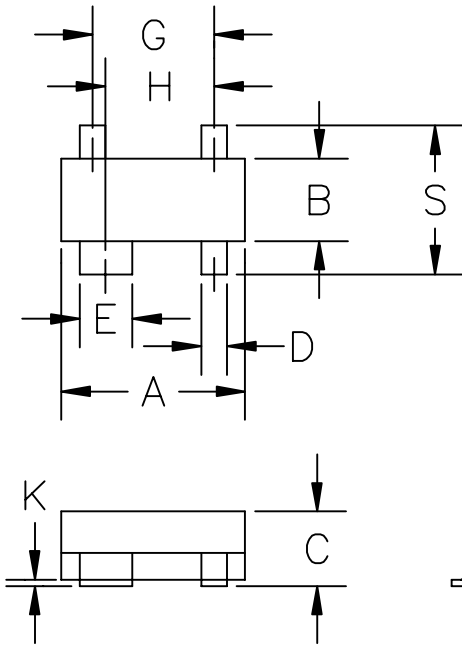

DIM <sup>N</sup>	INCHES		MM		NOTE
	MIN	MAX	MIN	MAX	
A	.110	.120	2.80	3.04	—
B	.047	.055	1.20	1.40	—
C	.031	.047	.80	1.20	—
D	.014	.018	.37	.510	—
E	.030	.035	.76	.940	—
G	.076	BSC	1.92	BSC	—
H	.068	BSC	1.72	BSC	—
J	.003	.005	.085	.180	—
K	.002	.005	.013	0.10	—
L	.010	.022	—	.55	REF
S	.082	.104	2.10	2.64	—

Notes:

- (1) Controlling dimension: Inch (unless otherwise specified).
- (2) Dimension A and B do not include mold protrusions. Mold protrusions are .006" max.

Land Pattern - SOT-143

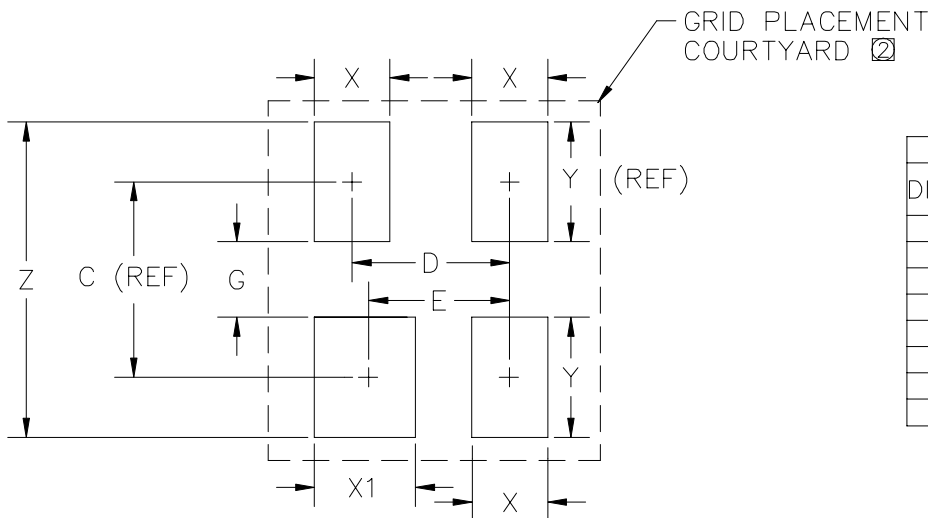

DIM <sup>N</sup>	INCHES		MM		NOTE
	MIN	MAX	MIN	MAX	
C	—	.087	—	2.20	—
D	.075	BSC	1.90	BSC	—
E	.067	BSC	1.70	BSC	—
G	.032	.040	.80	1.00	—
X	.032	.040	.80	1.00	—
X1	.040	.048	1.00	1.20	—
Y	—	.055	—	1.40	—
Z	.134	.140	3.40	3.60	—

- ② GRID PLACEMENT COURTYARD IS 8 X 8 ELEMENTS (4mm X 4mm) IN ACCORDANCE WITH THE INTERNATIONAL GRID DETAILED IN IEC PUBLICATION 97.
- ① CONTROLLING DIMENSION: MILLIMETERS.



**PROTECTION PRODUCTS****Marking Codes**

Part Number	Marking Code
SR05	R05

**Ordering Information**

Part Number	Working Voltage	Qty per Reel	Reel Size
SR05.TC	5V	3,000	7 Inch
SR05.TG	5V	10,000	13 Inch

**Contact Information**

Semtech Corporation  
Protection Products Division  
652 Mitchell Rd., Newbury Park, CA 91320  
Phone: (805)498-2111 FAX (805)498-3804