

## FM Sound IF for Television Applications with I<sup>2</sup>C Bus and SCART

TBA 130-2

Preliminary Data

Bipolar IC

### Features

- I<sup>2</sup>C bus control for the functions volume, muting, voice/music switching, as well as SCART recording/playback switching
- Integrated deemphasis resistor
- Low harmonic distortion factor

FM IF amplifier, comprising a limiter amplifier with an FM demodulator.

The AF section includes an SCART recording/playback switch, a voice/music switch, as well as a digital/analog converter to set the volume for the AF output. Control of volume, SCART recording/playback switch, and voice/music switch is achieved via an I<sup>2</sup>C bus serial interface.

The component is used in mono television sets with internal I<sup>2</sup>C bus control.

Type	Ordering Code	Package
TBA 130-2	Q67000-A8054	P-DIP-18

### Circuit Description

In its FM section, the component contains an eight-stage, symmetrical limiter amplifier with subsequent coincidence demodulator. The AF section contains a mute circuit, an analog switch for the SCART recording/playback function, as well as a 6-bit D/A converter to set the volume for the AF output, and a voice/music switch. Control of the D/A converter, the switch function for record/playback and voice/music is achieved via an I<sup>2</sup>C bus serial interface (ref. diagrams).

Data from the processor passes through an I<sup>2</sup>C bus control and is stored in registers according to its function (latch 1-3). If the bus is free, both lines will be in the mark state (SDA, SCL high). Each message begins with the start conditions: SDA goes L, while SCL remains H.

Any additional information transfer takes place while SCL = L, data is accepted by the control with the positive clock edge. If SDA goes H while the clock is H, the circuit recognizes a stop condition and thus, an end of the message.

The logic operates according to the table shown on page 375. All messages are transmitted byte-by-byte, followed by a ninth clock pulse, while the control returns the SDA line to L (acknowledge condition). The first byte consists of 7 address bits, with which the processor selects the TBA 130-2 from among several peripheral components (chip select). The eighth bit determines the direction of the subsequent data traffic (in this case read mode only).

The first and the second bit of the data bytes determine which latch will be called (sub-address). The volume information is contained in 6 bits (64 steps). For reasons of compatibility with the TDA 6200, a second bit with the same sub-address but with random contents must be transmitted for setting the volume.

Block Diagram

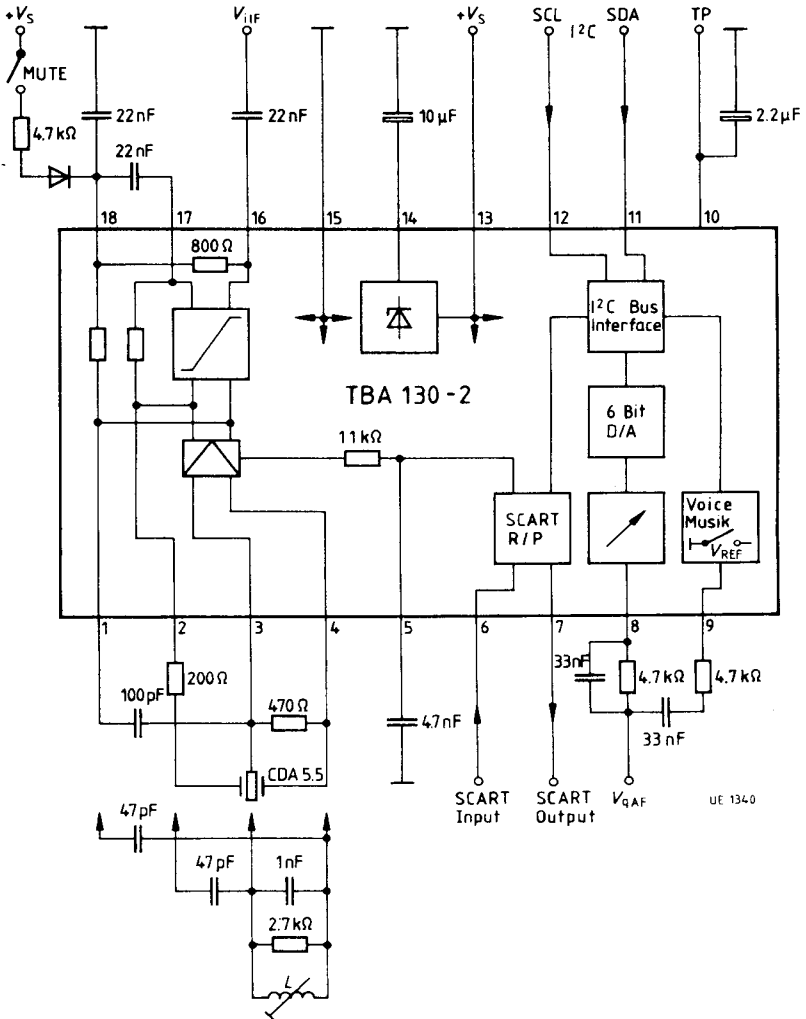

Expanded Block Diagram Part 1

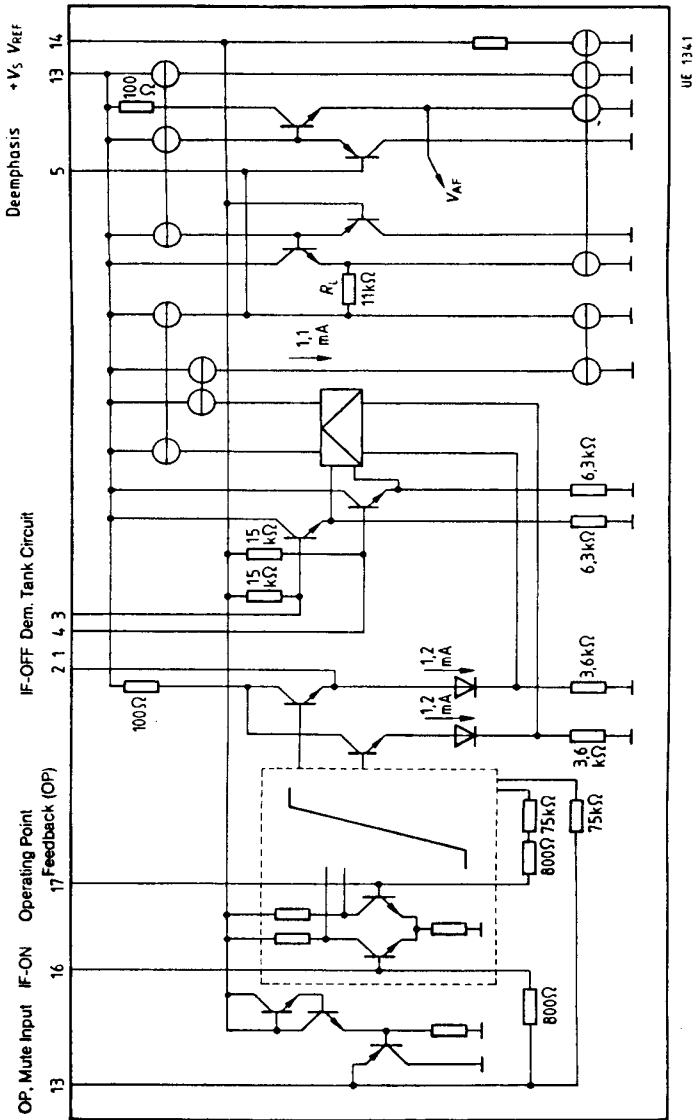

Expanded Block Diagram Part 2

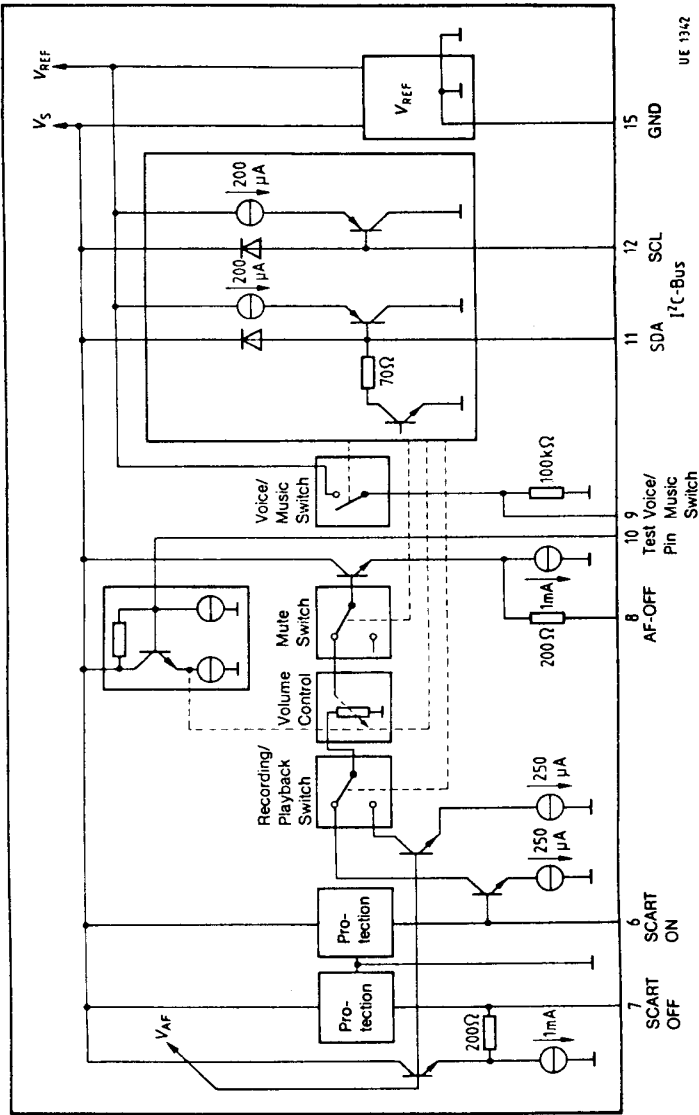

**Pin Functions**

<b>Pin No.</b>	<b>Function</b>
1, 2	IF amplifier output (emitter follower)
3, 4	Demodulator tank circuit connection (high impedance input – slope of S curve determined by external resistor between pins 3 and 4)
5	Connection for deemphasis capacitor (a series resistor of 11 k $\Omega$ is integrated)
6	AF input of SCART interface
7	AF output of SCART interface (emitter follower)
8	AF output (emitter follower)
9	Voice/music switch (open collector; max. 1 mA!)
10	Test pin (access to volume control)
11	Data input/output of the I <sup>2</sup> C bus control
12	Clock frequency input of the I <sup>2</sup> C (inter IC) bus control
13	Supply voltage
14	Internal reference voltage (6 V typ.)
15	GND
16	IF input (limiter amplifier input; internal resistor between pins 16 and 18 is 800 $\Omega$ typ.)
17	Limiter amplifier operating point feedback (RF decoupling of IF amplifier with appropriate capacitors if required)
18	Limiter amplifier operating point and low end; MUTE input (RF decoupling of IF amplifier with appropriate capacitors if required)

**Absolute Maximum Ratings**

Parameter	Symbol	Limit Values		Unit
		min.	max.	
Supply voltage	$V_S$	0	16	V
Reference current	$I_{REF}$	0	2	mA
IF input voltage	$V_{I16\text{ rms}}$	0	600	mV
DC voltage	$V_{3,4,6}$	0	$V_S$	V
DC voltage	$V_{11,12}$	0	$V_S$	V
DC voltage	$V_{16,17,18}$	0	$V_{REF}$	V
DC current	$I_{1,2}$	0	2	mA
DC current	$I_{5,7,8}$	- 1	2	mA
DC current	$I_9$	0	2	mA
Junction temperature	$T_j$		150	°C
Storage temperature	$T_{stg}$	- 40	125	°C
Thermal resistance (system-air)	$R_{th SA}$		80	K/W

**Operating Range**

Supply voltage	$V_S$	10.5	15.75	V
Frequency	$f$	0.1	12	MHz
Ambient temperature	$T_A$	0	70	°C

**Characteristics**
 $V_S = 12\text{ V}; T_A = 25\text{ }^\circ\text{C}; f_{114} = 5.5\text{ MHz}; \Delta f = \pm 30\text{ kHz}; f_{\text{mod}} = 1\text{ kHz}$ 

Parameter	Symbol	Limit Values			Unit
		min.	typ.	max.	
Current consumption	$I_S$	24	36	48	mA
Reference voltage	$V_{\text{REF}}$	5.4	6	6.6	V
Input voltage for limiter threshold $V_{Q7,8} = -3\text{ dB}$	$V_{I16\text{ rms}}$		50	100	$\mu\text{V}$
SCART output voltage $V_{I16\text{ rms}} = 10\text{ mV}$	$V_{Q7}$	450	650	850	mV
AF output voltage L byte = BF	$V_{Q8}$	450	650	850	mV
DC voltage portion $V_{I16\text{ rms}} = 10\text{ mV}; \Delta f = 0; THD = THD_{\text{min}}$	$V_{Q7}; V_{Q8}$		6		V
Total harmonic distortion $V_{I16\text{ rms}} = 10\text{ mV}$ L byte = BF	$THD_7; THD_8$			1	%
AM suppression <sup>1)</sup> $V_{I16\text{ rms}} = 500\text{ }\mu\text{V}; m = 30\%$	$\alpha_{\text{AM } 7,8}$	50	60		dB
Volume control L byte = 80-BF	$\Delta V_8$	80			dB
Max. input voltage SCART $THD_8 \leq 1\%$	$V_{I6\text{ rms}}$	2			V
Gain between SCART input (pin 6) and AF output (pin 8) L byte = BF	$G_{\text{SC}}$		0		dB

**Switching Voltage Muting**

ON (AF OFF)	$V_{18} =$	8		$V_S$	V
OFF	$V_{18} =$	0		3	V

**Voice / Music Switch ( $I_{O9} = 1\text{ mA}$ )**

V/M = 0 = high-ohmic $R_{\text{OFF}}$ Pin 14 $V_{\text{REF}}$		75	100		$\text{k}\Omega$
V/M = 1 = low-ohmic $R_{\text{ON}}$ DC voltage at pin 9 ( $I_{O9} = 0$ )	$V_9 =$	5.4	6	800 6.6	$\Omega$ V

1) Test conditions for the reference point  
 $f_{114} = 5.5\text{ MHz}; V_{I14\text{ rms}} = 10\text{ mV}; \Delta f = \pm 30\text{ kHz}; f_{\text{mod}} = 1\text{ kHz}$

**Characteristics (cont'd)** $V_S = 12\text{ V}$ ;  $T_A = 25\text{ }^\circ\text{C}$ ;  $f_{14} = 5.5\text{ MHz}$ 

Parameter	Symbol	Limit Values			Unit
		min.	typ.	max.	

**I<sup>2</sup>C Bus (SCL, SDA)  
Edges SCL, SDA**

Rise time	$t_r$			1	$\mu\text{S}$
Fall time	$t_f$			0.3	$\mu\text{S}$

**Shift Clock SCL**

Frequency	$f_{\text{SCL}}$	0		100	KHz
H-pulse width	$t_{\text{HIGH}}$	4			$\mu\text{S}$
L-pulse width	$t_{\text{LOW}}$	4			$\mu\text{S}$

**Start**

Set-up time	$t_{\text{SUSTA}}$	4			$\mu\text{S}$
Hold time	$t_{\text{HDSTA}}$	4			$\mu\text{S}$

**Stop**

Set-up time	$t_{\text{SUSTO}}$	4			$\mu\text{S}$
Bus free	$t_{\text{BUF}}$	4			$\mu\text{S}$

**Data Change**

Set-up time	$t_{\text{SUDAT}}$	1			$\mu\text{S}$
Hold time	$t_{\text{HDDAT}}$	1			$\mu\text{S}$

**Input SCL, SDA**

Input voltage	$V_{\text{IH}}$	2.4		5.5	V
	$V_{\text{IL}}$	0.3		1	V
Input current	$I_{\text{IH}}$			50	$\mu\text{A}$
	$I_{\text{IL}}$			100	$\mu\text{A}$



**Characteristics (cont'd)**
 $V_S = 12 \text{ V}; T_A = 25 \text{ }^\circ\text{C}; f_{i14} = 5.5 \text{ MHz}$ 

Parameter	Symbol	Limit Values			Unit
		min.	typ.	max.	

**Output SDA (open collector)**

Output voltage $R_L = 2.5 \text{ k}\Omega$ $I_{OL} = 2 \text{ mA}$	$V_{QH}$ $V_{QL}$			5.5 0.4	V V
--	----------------------	--	--	------------	--------

**Design-Related Characteristics**

Input resistance	$R_{13,4}$	20			$\text{k}\Omega$
Output resistance	$R_{Q7,8}$			200	$\Omega$
Input resistance	$R_{16}$	20			$\text{k}\Omega$
Input impedance	$Z_{16}$		800		$\Omega$
IF residual voltage $\Delta V_{S \text{ rms}} = 500 \text{ mV}; f_S = 100 \text{ Hz}$	$V_{Q7,8}$		10		mV
Hum suppression $V_S/V_{Q7,8}$ (without deemphasis C) $\Delta V_{S \text{ rms}} = 500 \text{ mV}; f_S = 100 \text{ Hz}$	$\alpha_{\text{hum}}$		30		dB
Crosstalk rejection <sup>1)</sup> $V_{6 \text{ rms}} = 2 \text{ V}; \text{SC} = 0$	$\alpha_{6-8}$	60			dB

<sup>1)</sup> Test conditions for the reference point  
 $f_{i14} = 5.5 \text{ MHz}; V_{i14 \text{ rms}} = 10 \text{ mV}; \Delta f = \pm 30 \text{ kHz}; f_{\text{mod}} = 1 \text{ kHz}$

Test Circuit

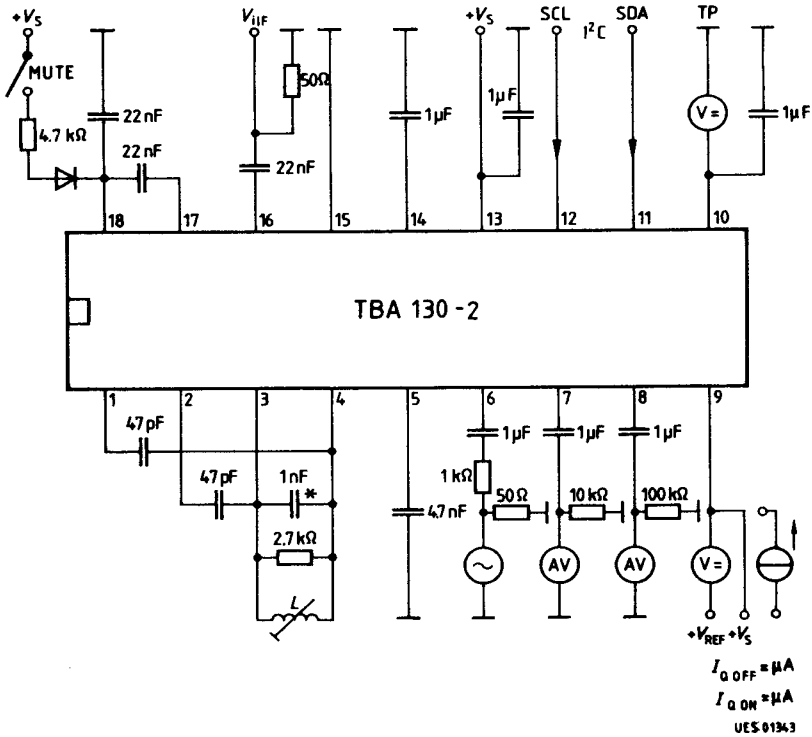

L: 10 turns, 0.2 CuL;  $Q_B$  approx. 25  
 e.g. Vogt Coil Assembly 517 12 000 00

\* STYROFLEX Capacitor

Application Circuit

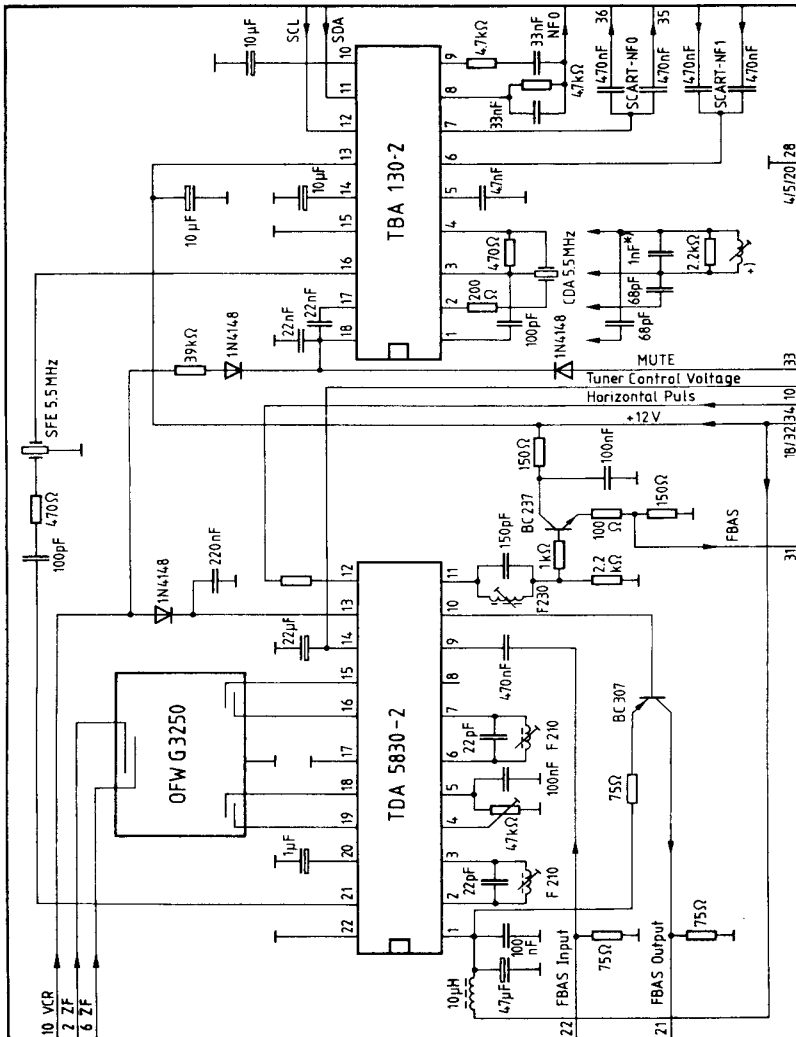

L: 10 turns, 0.2 CuL; Q<sub>v</sub> approx. 25  
 e.g. Vogt Coil Assembly 517 12 000 00

\* STYROFLEX Capacitor

**Software Definition**

The following data format is used:

1) **Chip Address**

MSB	LSB	
1	0	acknowledge
0	0	
0	0	
0	0	
0	0	
0	0	

MSB is transmitted first

2) **Data Bytes with Sub-Addresses**

a) volume

MSB	LSB	
1	0	
0	V <sub>05</sub>	V <sub>04</sub>
V <sub>03</sub>	V <sub>02</sub>	V <sub>01</sub>
V <sub>00</sub>	X	X
X	X	X
X	X	X
X	X	X

The second byte has to be included in the transfer

V<sub>x5</sub> = MSB

V<sub>x0</sub> = LSB

1	0	min. volume
0	0	
0	0	
0	0	
0	0	
0	0	
0	0	
0	0	
1	1	max. volume
1	1	
1	1	
1	1	
1	1	

b) SCART control byte

MSB	LSB	
1	SC	X
X	X	X
X	X	X
X	X	X
X	X	X
X	X	X
0	0	

SC = 1 SCART playback; SCART input is connected with AF output

SC = 0 standard operating mode

c) AF control byte

MSB	LSB	
0	0	
M	X	V/M
X	X	X
X	X	X
X	X	X

V/M = 0 pin 9 high-impedance

V/M = 1 pin 9 low-impedance

M = 1 muting for AF output

M = 0 AF ON

## I<sup>2</sup>C Bus Timing Diagram

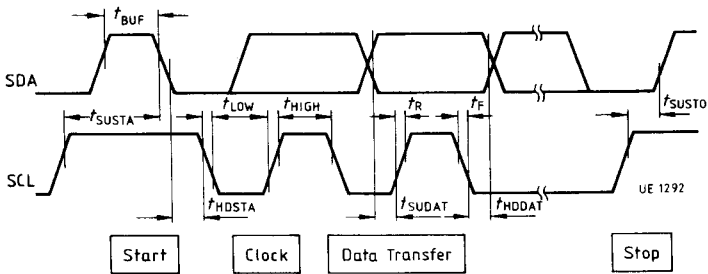

$t_{SUSTA}$	Set-up time (start)
$t_{HDSTA}$	Hold time (start)
$t_{HIGH}$	H- pulse width (clock)
$t_{LOW}$	L- pulse width (clock)
$t_{SUDAT}$	Set-up time (data transfer)
$t_{HDDAT}$	Hold time (data transfer)
$t_{SUSTO}$	Set-up time (stop)
$t_{BUF}$	Bus free
$t_F$	Fall time
$t_R$	Rise time

Above times are referenced to  $V_{IH}$  and  $V_{IL}$  values.