



MX23C3222

32M-BIT MASK ROM (16/32-BIT OUTPUT)

FEATURES

- Bit organization
 - 2M x 16 (word mode)
 - 1M x 32 (double word mode)
- Fast access time
 - Random access: 100ns (max.)
 - Page access: 30ns (max.)
- Page
 - 8 double words per page
- Current
 - Operating: 100mA
 - Standby: 50uA
- Supply voltage
 - 5V±10%
- Package
 - 70 pin SSOP (500mil)

PIN CONFIGURATION

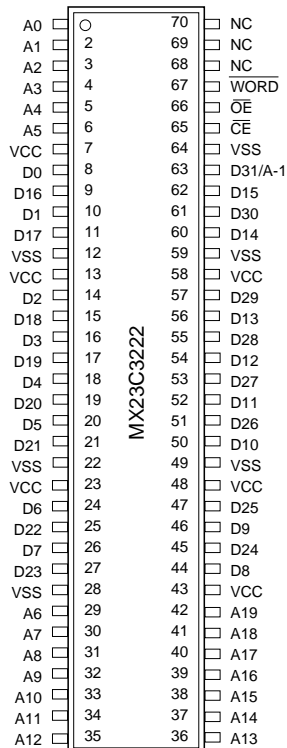

ORDER INFORMATION

Part No.	Access Time	Page Access Time	Package
MX23C3222MC-10	100ns	30ns	70 pin SSOP
MX23C3222MC-12	120ns	50ns	70 pin SSOP

PIN DESCRIPTION

Symbol	Pin Function
A0~A19	Address Inputs
D0~D30	Data Outputs
D31/A-1	D31 (Double Word Mode)/ LSB Address (Word Mode)
\overline{CE}	Chip Enable Input
\overline{OE}	Output Enable Input
\overline{Word}	Double Word/ Word Mode Selection
VCC	Power Supply Pin
VSS	Ground Pin
NC	No Connection

MODE SELECTION

CE	OE	\overline{Word}	D31/A-1	D0~D15	D16~D31	Mode	Power
H	X	X	X	High Z	High Z	-	Stand-by
L	H	X	X	High Z	High Z	-	Active
L	L	H	Output	D0~D15	D16~D31	Double Word	Active
L	L	L	Input	D0~D15	High Z	Word	Active

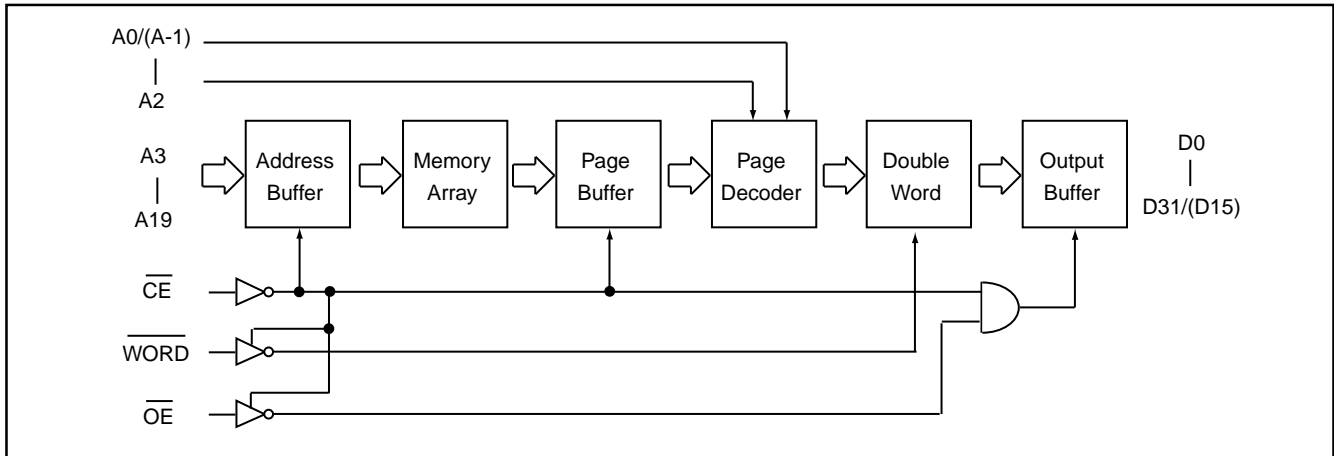
BLOCK DIAGRAM

ABSOLUTE MAXIMUM RATINGS

Item	Symbol	Ratings
Voltage on any Pin Relative to VSS	V _{IN}	-1.3V to VCC+2.0V (Note)
Ambient Operating Temperature	T _{opr}	0°C to 70°C
Storage Temperature	T _{stg}	-65°C to 125°C

Note: Minimum DC voltage on input or I/O pins is -0.5V. During voltage transitions, inputs may undershoot VSS to -1.3V for periods of up to 20ns. Maximum DC voltage on input or I/O pins is VCC+0.5V. During voltage transitions, input may overshoot VCC to VCC+2.0V for periods of up to 20ns.

DC CHARACTERISTICS (T_a = 0°C ~ 70°C, VCC = 5V±10%)

Item	Symbol	MIN.	MAX.	Conditions
Output High Voltage	V _{OH}	2.4V	-	I _{OH} = -1.0mA
Output Low Voltage	V _{OL}	-	0.4V	I _{OL} = 2.1mA
Input High Voltage	V _{IH}	2.2V	VCC+0.3V	
Input Low Voltage	V _{IL}	-0.3V	0.8V	
Input Leakage Current	I _{LI}	-	5uA	0V, VCC
Output Leakage Current	I _{LO}	-	5uA	0V, VCC
Operating Current	I _{CC1}	-	100mA	t _{RC} = 100ns, all output open
Standby Current (TTL)	I _{STB1}	-	1mA	$\overline{CE} = V_{IH}$
Standby Current (cmos)	I _{STB2}	-	50uA	$\overline{CE} > VCC - 0.2V$
Input Capacitance	C _{IN}	-	10pF	T _a = 25°C, f = 1MHZ
Output Capacitance	C _{OUT}	-	10pF	T _a = 25°C, f = 1MHZ

AC CHARACTERISTICS ($T_a = 0^\circ\text{C} \sim 70^\circ\text{C}$, $V_{CC} = 5V \pm 10\%$)

Item	Symbol	23C3222-10		23C3222-12	
		MIN.	MAX.	MIN.	MAX.
Read Cycle Time	tRC	100ns	-	120ns	-
Address Access Time	tAA	-	100ns	-	120ns
Chip Enable Access Time	tACE	-	100ns	-	120ns
Page Mode Access Time	tPA	-	30ns	-	50ns
Output Enable Time	tOE	-	30ns	-	50ns
Output Hold After Address	tOH	0ns	-	0ns	-
Output High Z Delay	tHZ	-	20ns	-	20ns

Note: Output high-impedance delay (tHZ) is measured from OE or CE going high, and this parameter guaranteed by design over the full voltage and temperature operating range - not tested.

AC Test Conditions

Input Pulse Levels	0.4V~ 2.4V
Input Rise and Fall Times	10ns
Input Timing Level	1.5V
Output Timing Level	0.8V and 2.0V
Output Load	See Figure

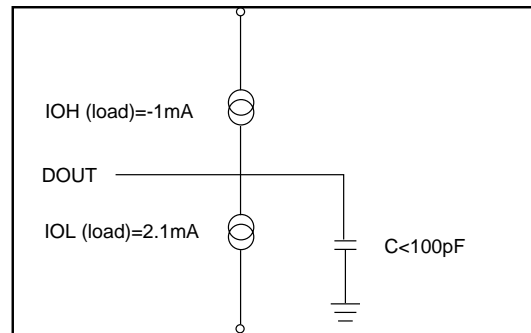

Note: No output loading is present in tester load board.

Active loading is used and under software programming control.

Output loading capacitance includes load board's and all stray capacitance.

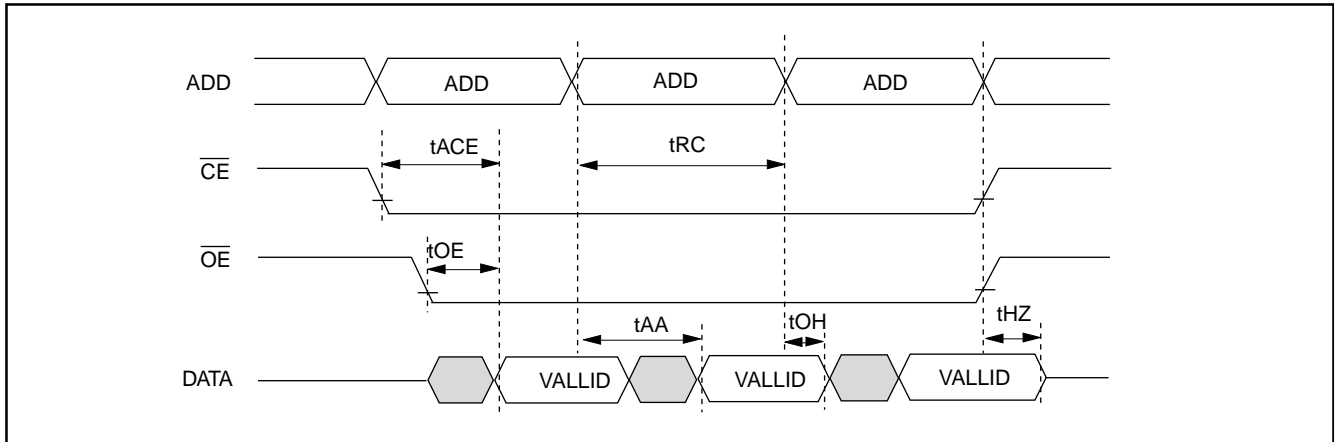
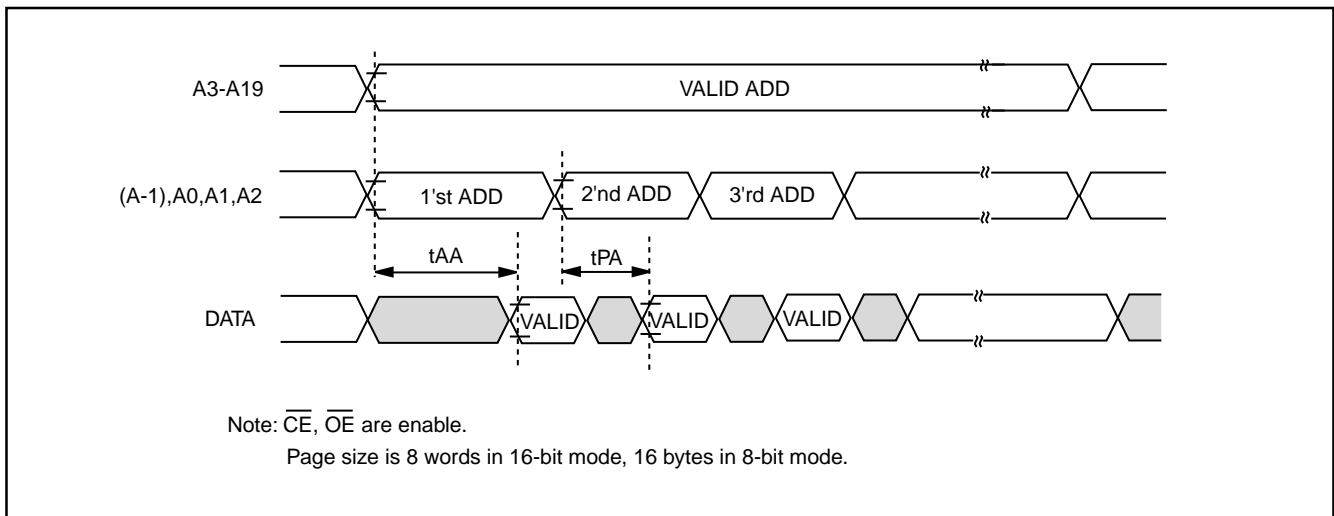
TIMING DIAGRAM
RANDOM READ

PAGE READ



REVISION HISTORY

Revision	Description	Page	Date
2.3	AC Characteristics: tOH 10ns --> 0ns	P3	FEB/01/1999



MX23C3222

MACRONIX INTERNATIONAL CO., LTD.

HEADQUARTERS:

TEL:+886-3-578-8888

FAX:+886-3-578-8887

EUROPE OFFICE:

TEL:+32-2-456-8020

FAX:+32-2-456-8021

JAPAN OFFICE:

TEL:+81-44-246-9100

FAX:+81-44-246-9105

SINGAPORE OFFICE:

TEL:+65-747-2309

FAX:+65-748-4090

TAIPEI OFFICE:

TEL:+886-3-509-3300

FAX:+886-3-509-2200

MACRONIX AMERICA, INC.

TEL:+1-408-453-8088

FAX:+1-408-453-8488

CHICAGO OFFICE:

TEL:+1-847-963-1900

FAX:+1-847-963-1909

[http : //www.macronix.com](http://www.macronix.com)